



# Ice Cream / Food Display Freezers



**SD-220Q**



**SD-420Q**



**WRE-5BDTM**

## Features

- Fully self-contained unit
- LED lighting
- Sliding top glass
- Baskets included
- Curved tempered glass with locks
- Included castors with brakes
- Adjustable thermostat
- Defrost drain opening



**WR Distribution**

info@wr.ca | P: 1-888-443-1946 | www.wr.ca





# Novelty - Specifications

<u>Model #</u>	<u>Voltage / Frequency</u>	<u>External Dimensions</u>	<u>Capacity (Cu.Ft.)</u>	<u>Temperature range</u>	<u>Basket Qty</u>	<u>Refrigerant</u>
SD-220Q	115V /60Hz	29" W X 26.5" D x 34" H	6.4	-23 to -18C	2	R290
SD-420Q	115V /60Hz	50" W X 26.5" D x 34" H	13.7	-23 to -18C	4	R290
WRE-5BDTM	110V / 60Hz	50" W X 27" D x 34" H	12.9	-26 to -9C	5	R290

## Line Drawings

*Front View*

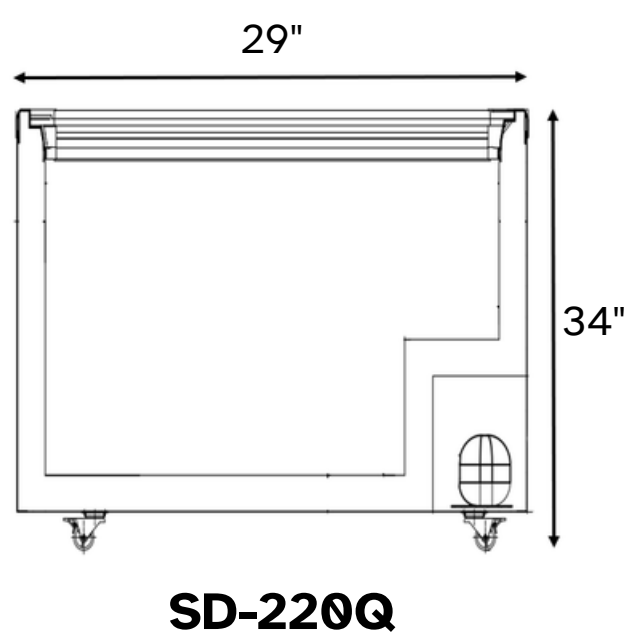

**SD-220Q**

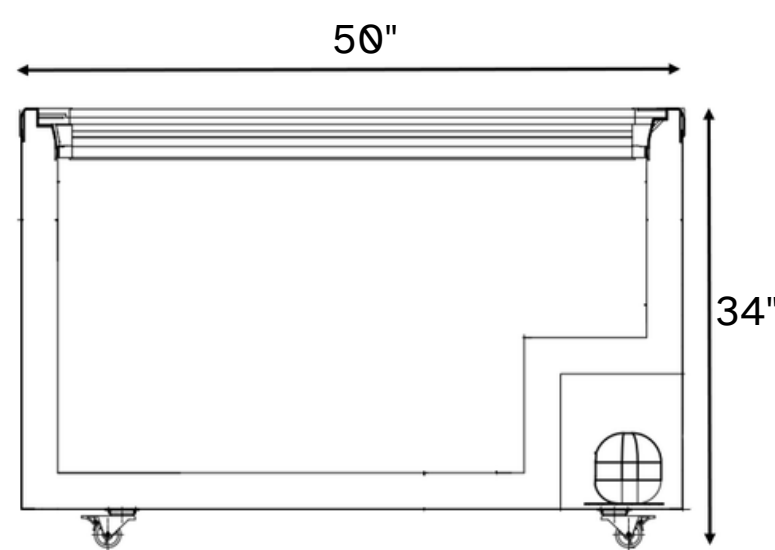

**SD-420Q**

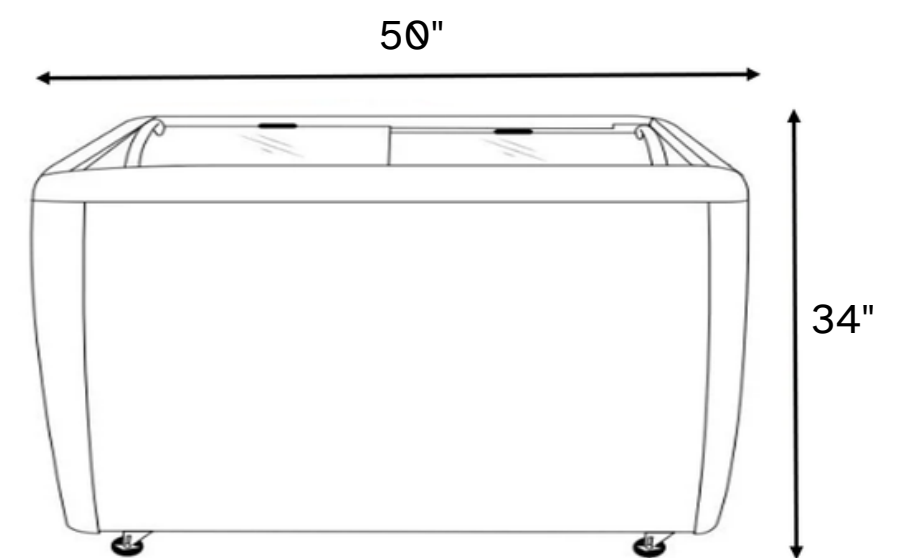

**WRE-5BDTM**

*Side View*

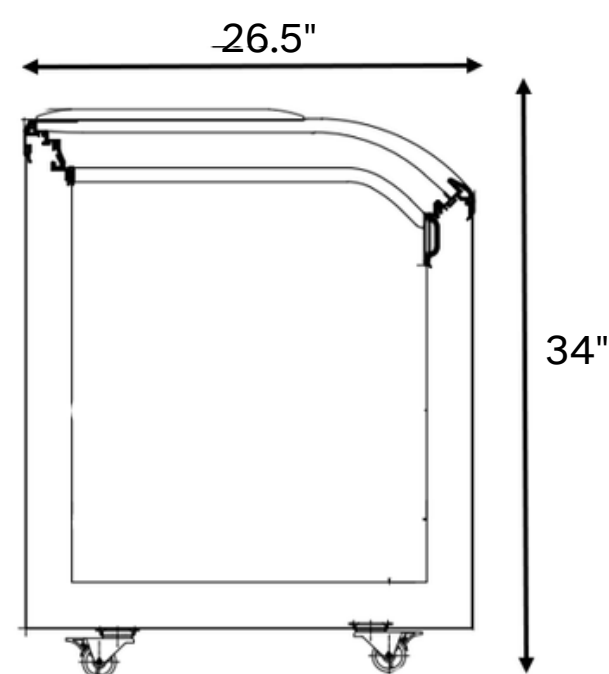

**SD-220Q / SD420Q**

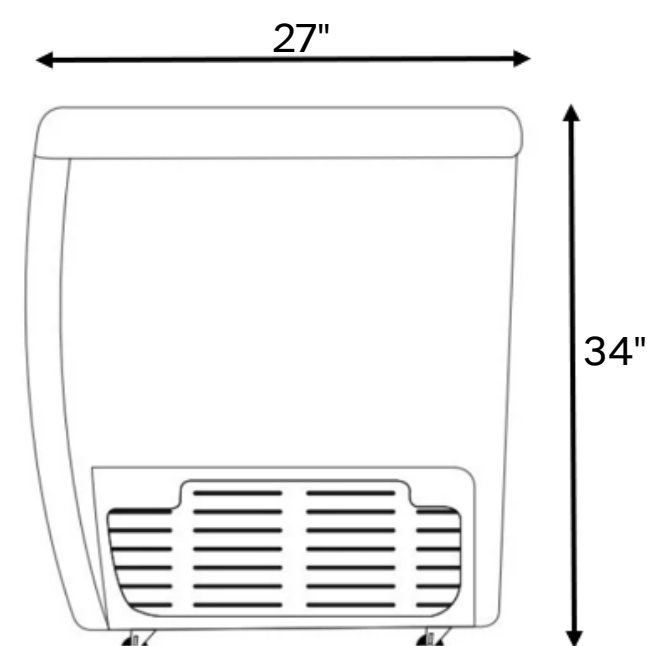

**WRE-5BDTM**

## Warranty

- 1 Year Parts & Labor Warranty
- 5 Year Compressor Part Warranty



**WR Distribution**

info@wr.ca | P: 1-888-443-1946 | www.wr.ca

