

Snooker®



SK-219S

UNDERCOUNTER CUBE ICE MACHINE



Features

- ETL/ETLS Certification
- 26" wide
- 80 lbs Ice Storage
- 210 lbs Production / 24 hrs
- R290 Refrigerant
- Stainless steel exterior
- Automatic fault alert system
- Efficient ice production
- Front air discharge for compact spaces
- Digital control panel with ice thickness adjust function
- Premium water filter included

Standard Warranty



- 3 year parts, labour & compressor warranty

Operating Requirements

Minimum Maximum

Ambient Air Temperature

5 °C (41 °F) 40 °C (104 °F)

Water Temperature

5 °C (41 °F) 35 °C (95 °F)

Ice Forms



Full Cube (mm)
22 x 22 x 22



Half Cube (mm)
22 x 13 x 22

Model	Condensing Unit	Refrigerant Gas	Ice Production per 24 hrs		
			50°F air/ 50°F water	70°F air/ 50°F water	90°F air/ 70°F water
SK-219S	Air Cooled	R290	223 lbs	206 lbs	175 lbs



Proud Canadian Distributor:

WESTERN REFRIGERATION & BEVERAGE EQUIPMENT LTD.

1-888-443-1946 | info@wr.ca | www.wr.ca



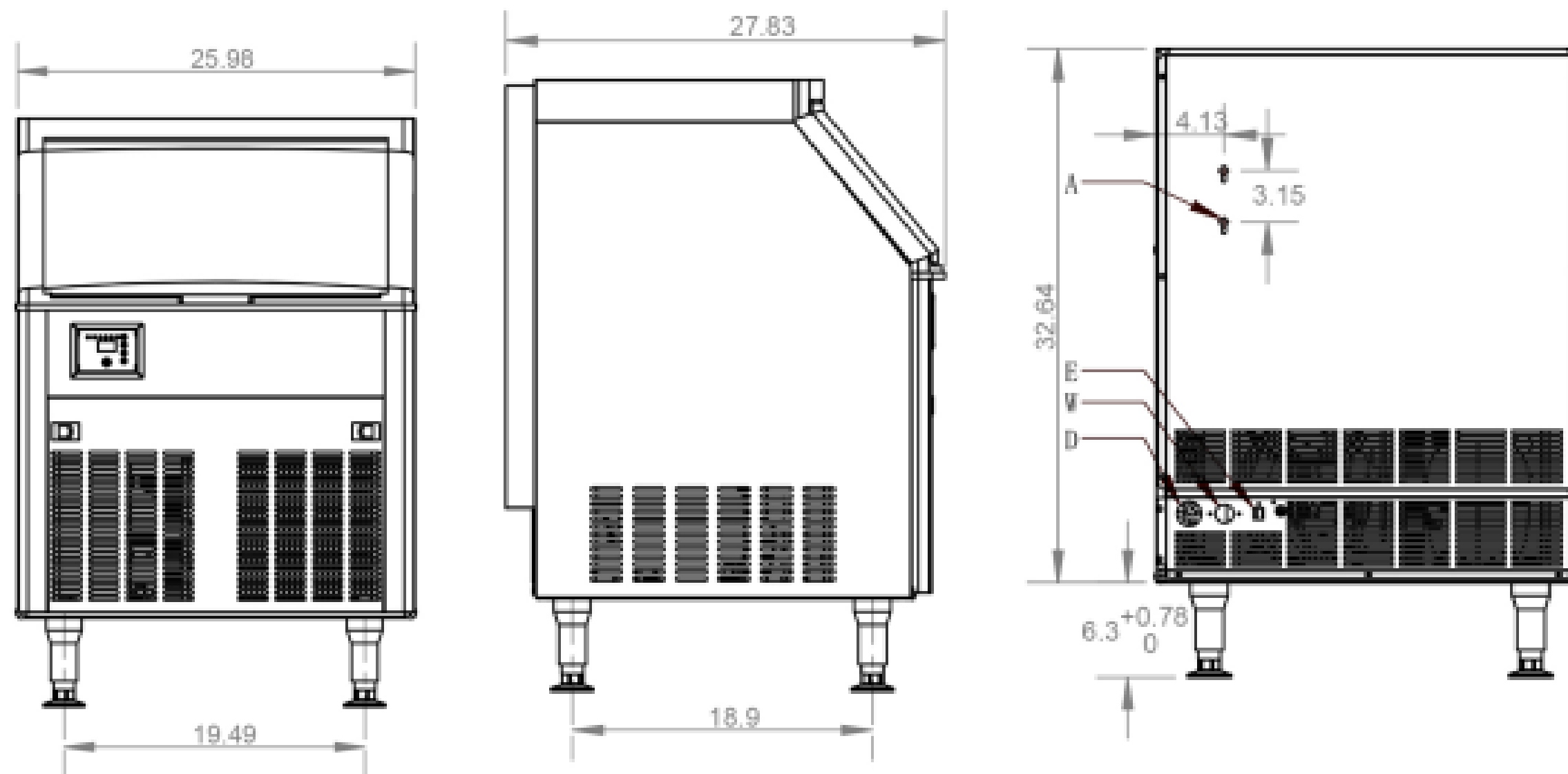

W: Water inlet
D: Drain
E: Power input
A: Water filter placement

Voltage	Dimensions (in) (W x D x H)	Net Weight	Shipping Dimensions (in) (W x D x H)	Gross Weight
115/60/1ph	26" x 26.96" x 38.18"	127 lbs	42" x 42" x 40.5"	181 lbs

Maintenance and cleaning are not covered under warranty

- All Ice machines should have a water filter system & cartridge installed. Recommended cartridge replacement is recommended every 6 months. (may vary based on water quality)