

Snooker®

SK-559G

PEARL ICE MACHINE



Image shown with B-305 Ice Bin

Features

- ETL/ETLS Certification
- 22" wide
- 350 lbs Production / 24 hrs
- R290 Refrigerant
- Stainless steel exterior
- Automatic fault alert system
- Efficient ice production
- Digital control panel with ice thickness adjust function
- Premium water filter included
- SK-559G ice machine is compatible with 22" wide bins (recommended bin: B-305)



Standard Warranty

- 3 year parts, labour & compressor warranty

Operating Requirements

	Minimum	Maximum
<u>Ambient Air Temperature</u>	5 °C (41 °F)	40 °C (104 °F)
<u>Water Temperature</u>	5 °C (41 °F)	35 °C (95 °F)

Ice Form



Pearl Ice (mm)
11 x 11 x 15

<u>Model</u>	<u>Condensing Unit</u>	<u>Refrigerant Gas</u>	<u>Ice Production per 24 hrs</u>		
			50°F air/ 50°F water	70°F air/ 50°F water	90°F air/ 70°F water
SK-559G	Air Cooled	R290	614 lbs	523 lbs	362 lbs

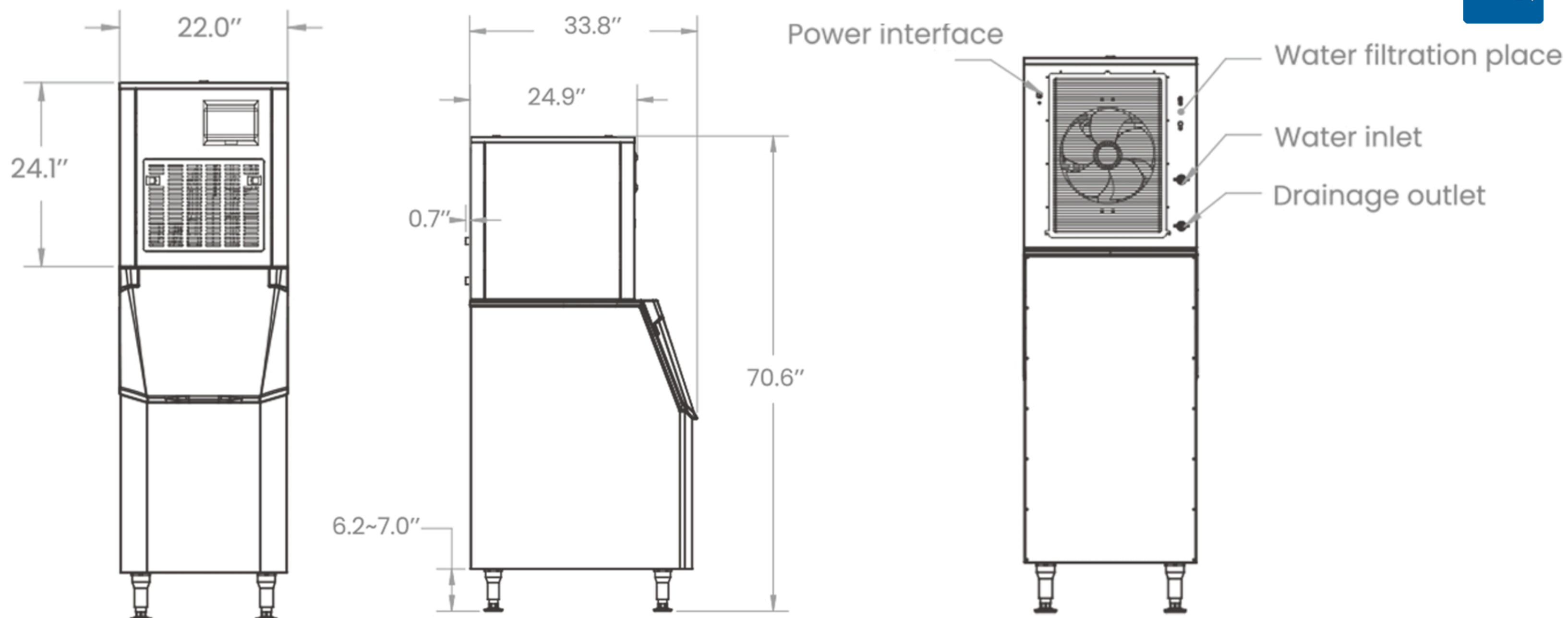

Voltage	Dimensions (in) (W x D x H)	Net Weight	Shipping Dimensions (in) (W x D x H)	Gross Weight
115/60/1ph	22.05" x 24.33" x 24.2"	176 lbs	42" x 42" x 29.5"	234 lbs

Maintenance and cleaning are not covered under warranty

- All Ice machines should have a water filter system & cartridge installed. Recommended cartridge replacement is recommended every 6 months. (may vary based on water quality)