

NORIOTA



NF23

NF23 REACH-IN FREEZER, 1 SOLID DOOR

FEATURES AND BENEFITS

- **201 Stainless Steel Interior (Floor, Walls, Ceiling):** Provides durable corrosion resistance, strong resistance to dents and deformation, and smooth surfaces that are easier to clean in daily commercial use.
- **Ventilated Cooling System:** Circulates cold air throughout the cabinet to support more even temperature distribution.
- **Solid Door with Self-Closing Hinges:** Helps reduce unnecessary temperature loss by encouraging the door to return closed after use.
- **Heavy-Duty Adjustable Shelves:** White coated wire shelves support up to 50 kg (110 lb) each for flexible storage of heavy commercial product loads.
- **Digital Temperature Control & Display:** Enables accurate temperature monitoring, easy adjustments, and includes high-temperature and door-open alarms for added protection and operational awareness.
- **Full-Perimeter Magnetic Door Gaskets:** Creates a tight seal to lock in cold air and maintain optimal internal temperature.
- **Efficient LED Interior Lighting:** Delivers bright, low-heat illumination for quick and easy product identification.
- **R290 Refrigerant:** Uses environmentally friendlier hydrocarbon refrigerant with low environmental impact.

NORIOTA

www.noriota.ca | support@noriota.ca | 1-877-NORIOTA

NORIOTA

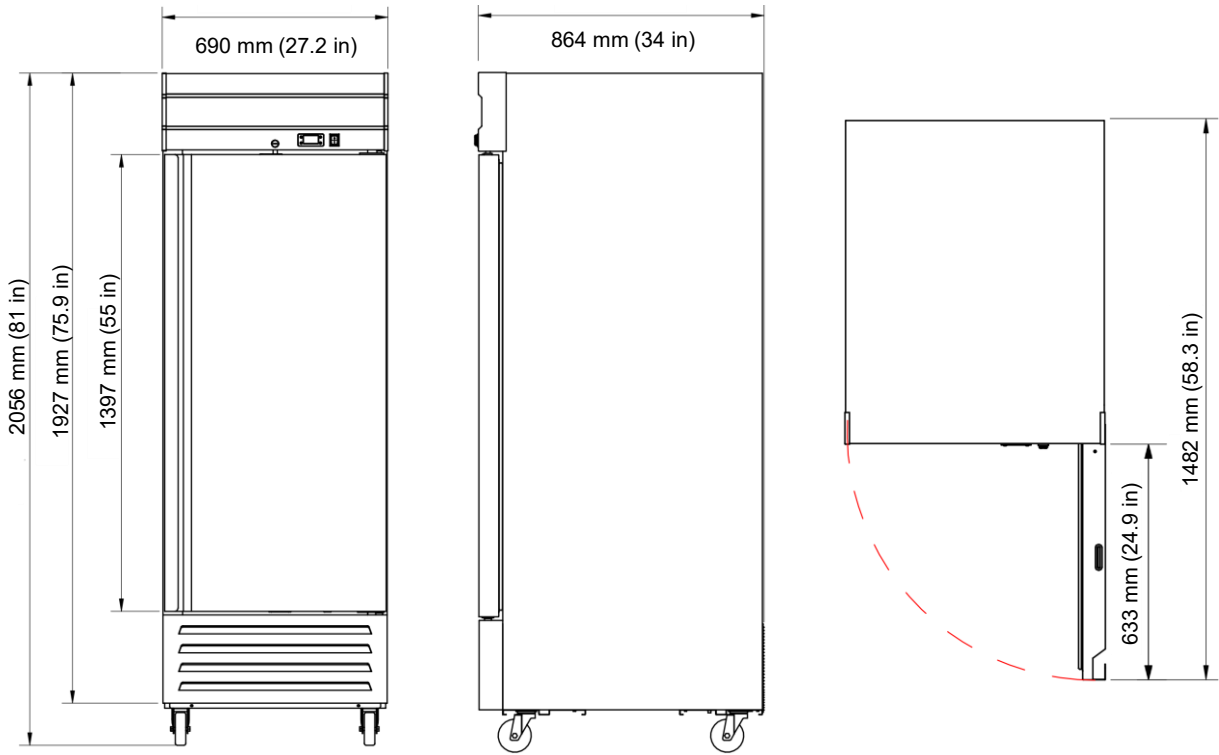

NF23 REACH-IN FREEZER, 1 SOLID DOOR

Model No.	NF23
Net Storage Capacity	542 L (19.1 CuFt)
Doors / Shelves	1 Door, 3 Shelves
Holding Temperature	-23 °C to -12 °C (-10 °F to 10 °F)
Defrost	Automatic
Refrigerant	R290 (62 g)
Compressor Location	Bottom Mounted
Shelf Size	54 x 64.8 cm (21.3 x 25.5 in)
Shelf Weight Capacity	50 kg (110 lb)
Electrical	115V / 60Hz / 1Ph / 3.1 A
Power Input	340 W
Power Consumption	4.4 kWh/day
Plug Type	NEMA5-15P
Cord Length	250 cm (98.4 in)
Interior Lighting	LED Lighting
Door Style	Swing
Door Type	Solid
Lock and Keys	Yes
Installation Type	Freestanding
Product Dimensions	69 x 86.4 x 205.6 cm (27.2 x 34 x 81 in)
Product Internal Dimensions	56.6 x 73.5 x 130.5 cm (22.2 x 29 x 51.3 in)
Product Weight	97 kg (213.4 lb)
Shipping Dimensions	73 x 91 x 209 cm (28.7 x 35.8 x 82.3 in)
Shipping Weight	125.5 kg (276.7 lb)
Warranty	2 years parts & labour, 5 years compressor parts only

NORIOTA

www.noriota.ca | support@noriota.ca | 1-877-NORIOTA

March 2026

All specifications subject to change without notice.