

N O R I O T A

ANSI Z83.11-2016
CSA 1.8-2016

Intertek
ANSI/NSF 4



NR24

NR24 GAS RANGE WITH OVEN, 4 BURNERS, 24 IN

FEATURES AND BENEFITS

Stainless steel front, back riser, shelf, and support legs: Durable commercial construction with a clean professional appearance.

Ships configured for natural gas, field convertible to LPG: Provides installation flexibility using included conversion components.

4 open burners, 30,000 BTU/hr each: Strong top heat for boiling, sautéing, and other high-demand commercial cooking tasks.

Removable 30.5 x 30.5 cm (12 x 12 in) cast iron grates: Heavy-duty grate design supports cookware securely and simplifies cleaning.

Independent manual controls with standing pilots: Provides straightforward operation and individual flame control at each burner.

30,000 BTU/hr oven: Delivers reliable heat for everyday baking, roasting, and finishing tasks.

Adjustable oven thermostat, 121 °C to 288 °C (250 °F to 550 °F): Provides flexible temperature control across a wide range of cooking applications.

Spring-assisted oven door with cool-touch handle: Supports easier daily use and safer handling during busy service.

Steel oven sides with porcelain bottom: Built for commercial use with a smooth oven floor that is easier to clean.

Removable crumb tray and two oven racks included: Helps simplify cleanup and supports flexible oven setup.

NORIOTA

www.noriota.ca | support@noriota.ca | 1-877-NORIOTA

N O R I O T A

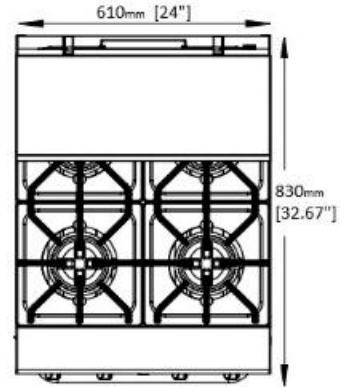
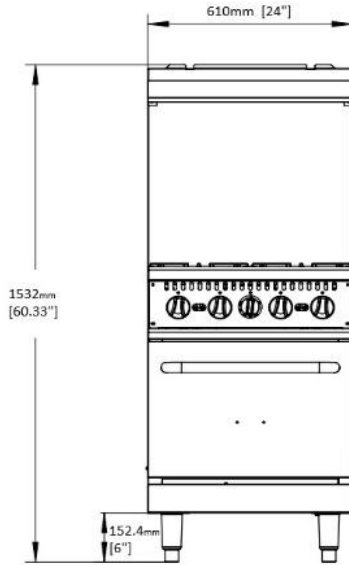
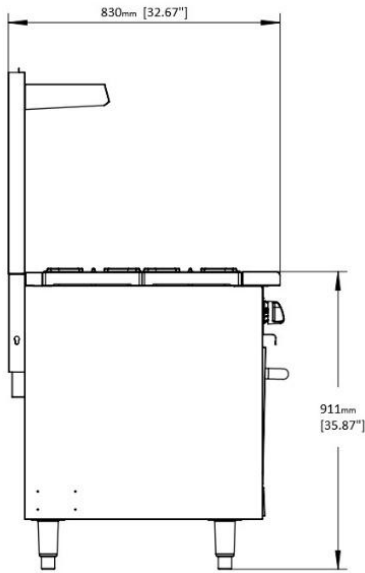

NR24 GAS RANGE WITH OVEN, 4 BURNERS, 24 IN

Technical Data

Gas Type	Ships configured for Natural Gas, field convertible to Liquid Propane (LPG) using included conversion components
Gas Connection	3/4 in NPT
Minimum Supply Pressure	Natural Gas: 5 in. W.C., Liquid Propane: 10 in. W.C.
Top Configuration	4 open burners with removable cast iron grates
Burner Input	30,000 BTU/hr per burner
Number of Burners	4
Oven Input	30,000 BTU/hr
Number of Ovens	1
Total Heat Input	150,000 BTU/hr total (120,000 burners + 30,000 oven)
Ignition Type	Standing pilot
Burner Control	Independent manual control valve for each burner
Burner Grates	30.5 x 30.5 cm (12 in x 12 in), removable cast iron
Front Ledge	12.7 cm (5 in) deep, stainless steel
Oven Dimensions (W x D x H)	52 x 66 x 35.6 cm (20.5 x 26 x 14 in)
Oven Thermostat Range	121°C – 288 °C (250 °F – 550 °F)
Oven Interior	Steel sides with porcelain bottom
Oven Racks	2 racks, multiple position
Oven Door	Stainless steel, spring-assisted closing with cool-touch handle
Back Riser	62.9 cm (24.75 in) high
Legs / Castors	15.2 cm (6 in) adjustable stainless steel legs, castors optional
Flue / Exhaust Requirements	Rear flue, requires installation under a commercial ventilation hood in accordance with local codes
Unit Dimensions (W x D x H)	61 x 83 x 153.2 cm (24 x 32.67 x 60.33 in)
Working Height	91.1 cm (35.9 in)
Unit Weight	131.2 kg (289.3 lb)
Shipping Dimensions (W x D x H)	72 x 101 x 89 cm (28.4 x 39.8 x 35.1 in)
Shipping Weight	161.5 kg (355.3 lb)
Warranty	2 years parts & labour
Includes	(1) stainless back riser, (2) oven racks, (1) crumb tray, (4) adjustable legs, (1) gas conversion kit

NORIOTA

www.noriota.ca | support@noriota.ca | 1-877-NORIOTA

March 2026

All specifications subject to change without notice.