

NORIOTA

GAS THERMOSTATIC GRIDDLES – HEAVY DUTY



NTG24



NTG48



NTG36



NTG60

FEATURES & BENEFITS

- **Precise Temperature Control:** Thermostatic regulation from 93 °C to 232 °C (200 °F to 450 °F) ensures consistent cooking temperatures, even during peak hours
- **Durable Construction:** Stainless steel front, bullnose, and sides, along with a fully welded 7.6 cm (3 in) grease trough and splash guard, provide strength and long-lasting durability
- **High-Performance Griddle Plate:** A 2.5 cm (1 in) thick polished steel griddle plate with a 55.9 cm (22 in) deep cooking surface delivers even heat distribution and excellent cooking results
- **Efficient Burners:** Powerful 30,000 BTU “U” shaped burners for every 30.5 cm (12 in) of cooking width ensure fast heat recovery and uniform heat distribution
- **Easy Ignition:** Each burner includes an individual standing pilot and control knob for quick and reliable ignition
- **Easy Cleaning:** A removable drip tray simplifies maintenance and keeps the cooking area clean
- **Adjustable Legs:** Heavy-duty 10.1 cm–12.7 cm (4 in–5 in) steel legs with adjustable feet provide stability and flexibility in installation
- **Versatile Gas Compatibility:** Ships ready for natural gas use but can be easily converted to liquid propane in the field with included parts

GAS

NTG*N: Natural Gas

Field convertible to Liquid Propane with included components 3/4” gas connection

Minimum supply pressure:

4” W.C. for Natural Gas

10” W.C. for Liquid Propane

WARRANTY

2-year parts & labour

NORIOTA

GAS THERMOSTATIC GRIDDLES – HEAVY DUTY

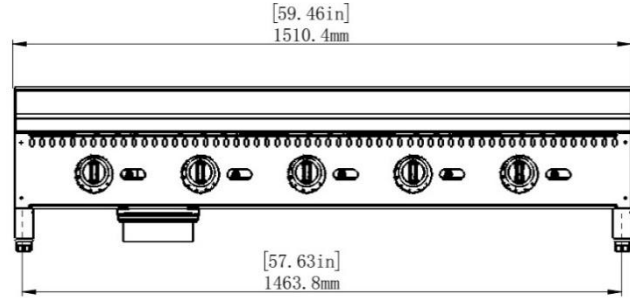
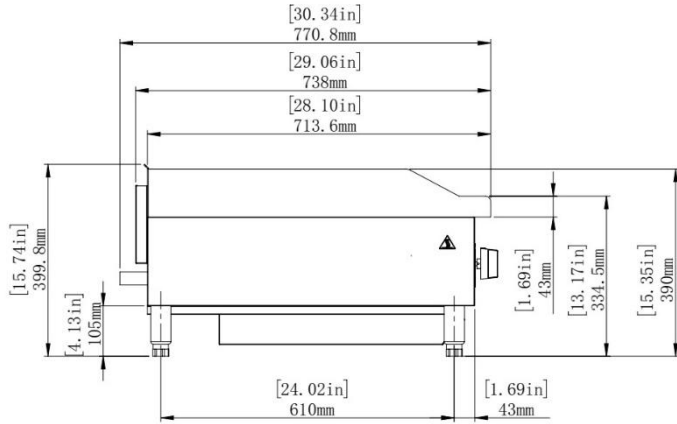

NTG60

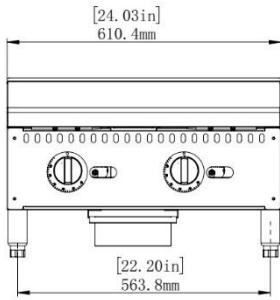

NTG24

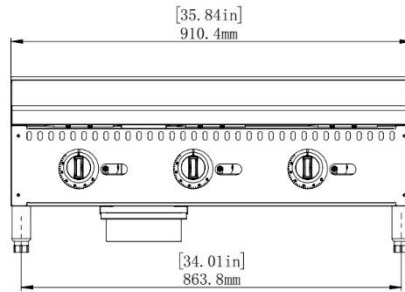

NTG36

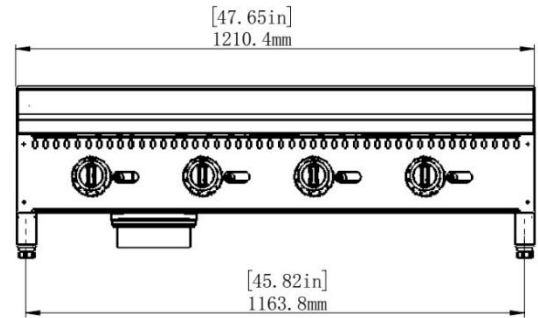

NTG48

| | NTG24 | NTG36 | NTG48 | NTG60 |
|--|---|--|---|---|
| BTU | 60,000 | 90,000 | 120,000 | 150,000 |
| # of Burners | 2 | 3 | 4 | 5 |
| Gridle Plate | 2.5 cm (1 in) Thick Steel | | | |
| Cooking Surface Size | 60.6 x 56.4 cm 23.9 x 22.2 in | 90.6 x 56.4 cm 35.7 x 22.2 in | 120.6 x 56.4 cm 47.5 x 22.2 in | 150.6 x 56.4 cm 59.3 x 22.2 in |
| Temperature Control | Adjustable Thermostat (1 Per Burner) | | | |
| Temperature Range | 93.3 °C to 232.2 °C (200 °F to 450 °F) | | | |
| Ignition | Standing Pilot | | | |
| Backsplash | Welded Stainless Steel, 7.6 cm (3 in) High | | | |
| Removable Drip Trays | Yes, Stainless Steel | | | |
| Grease Trough | Yes, 7.6 cm (3 in) Wide | | | |
| Legs | Adjustable 10 - 12.7 cm (4 to 5 in) Stainless Steel | | | |
| Unit Dimensions (W x D x H) | 61 x 73.8 x 33.5 cm 24 x 29 x 13.2 in | 91 x 73.8 x 33.5 cm 35.8 x 29 x 13.2 in | 121 x 73.8 x 33.5 cm 47.7 x 29 x 13.2 in | 151 x 73.8 x 33.5 cm 59.5 x 29 x 13.2 in |
| Unit Weight | 90.5 kg (199.5 lb) | 129.5 kg (285.5 lb) | 165 kg (363.8 lb) | 204.5 kg (450.8 lb) |
| Shipping Dimensions (W x D x H) | 66 x 83 x 35 cm 26 x 32.7 x 13.8 in | 96 x 83 x 35 cm 37.8 x 32.7 x 13.8 in | 126 x 83 x 35 cm 49.6 x 32.7 x 13.8 in | 156 x 83 x 35 cm 61.4 x 32.7 x 13.8 in |
| Shipping Weight | 110.5 kg (243.6 lb) | 156 kg (343.9 lb) | 196 kg (432.1 lb) | 242.5 kg (534.6 lb) |

Includes

(4) adjustable legs, (1) gas conversion kit