

Project: \_\_\_\_\_

Item #: \_\_\_\_\_

Quantity: \_\_\_\_\_

### Up to 30% Less\* Gas Consumption



### SHORT FORM SPECIFICATION

Heavy-duty countertop gas manual griddle, VORTEX Model No. \_\_\_\_\_. Fully welded stainless and aluminum steel chassis with 14-gauge 304 stainless steel front and sides. Cast iron rectangle-shaped atmospheric burners rated at 27,000 BTU/hr, spaced every 12 inches for consistent heat distribution. Radiant heating system enhances thermal uniformity and recovery. Standard 1" (25mm) thick steel griddle plate provides strong heat retention and searing performance. Stainless steel grease drawer system; dual drawers on wider models. 4-inch adjustable legs; 3/4-inch rear gas connection.

*\*Actual gas savings will vary based on model, configuration, and operating conditions*

### CERTIFICATIONS



### MODEL SERIES

- VRX-24-MG     VRX-36-MG     VRX-48-MG  
 VRX-60-MG

### APPLICATIONS

- Best Applications for a Standard Griddle
- High-heat cooking applications where aggressive searing and charring are preferred
- Operations prioritizing lower upfront equipment cost over energy efficiency
- Back-of-house kitchens where appearance is less critical than durability and flexibility
- Kitchens that prefer traditional griddle performance for burgers, onions, hash browns, and proteins with heavy seasoning

### FEATURES

- Heavy-duty 14-gauge 304 stainless steel construction
- 1-inch thick griddle plate for even heat
- High-output 27,000 BTU burners every 12 inches
- Manual control (200°F (93°C) to 550°F (288°C))
- Welded grease gutter, chute, and large-capacity grease drawer
- Piezo ignition and built-in safety valves
- Modular design for quick service access

### BENEFITS

- High-efficiency infrared burner technology delivers faster heat-up and more consistent cooking performance
- Lower gas consumption and reduced operating costs compared to traditional atmospheric burners
- Handles very high cooking temperatures for aggressive searing and browning
- Traditional steel surface delivers strong flavor development and caramelization
- Durable plate construction stands up to heavy scraping and constant use
- Lower initial equipment cost compared to specialty griddle surfaces
- Familiar operation and maintenance for most kitchen staff
- Reliable heat retention supports steady production during peak periods
- Forgiving surface makes it well suited for varied cooking techniques
- Simple, widely available cleaning tools and procedures

Project: \_\_\_\_\_

Item #: \_\_\_\_\_

Quantity: \_\_\_\_\_

**PLAN VIEW / EQUIPMENT DIMENSIONS**

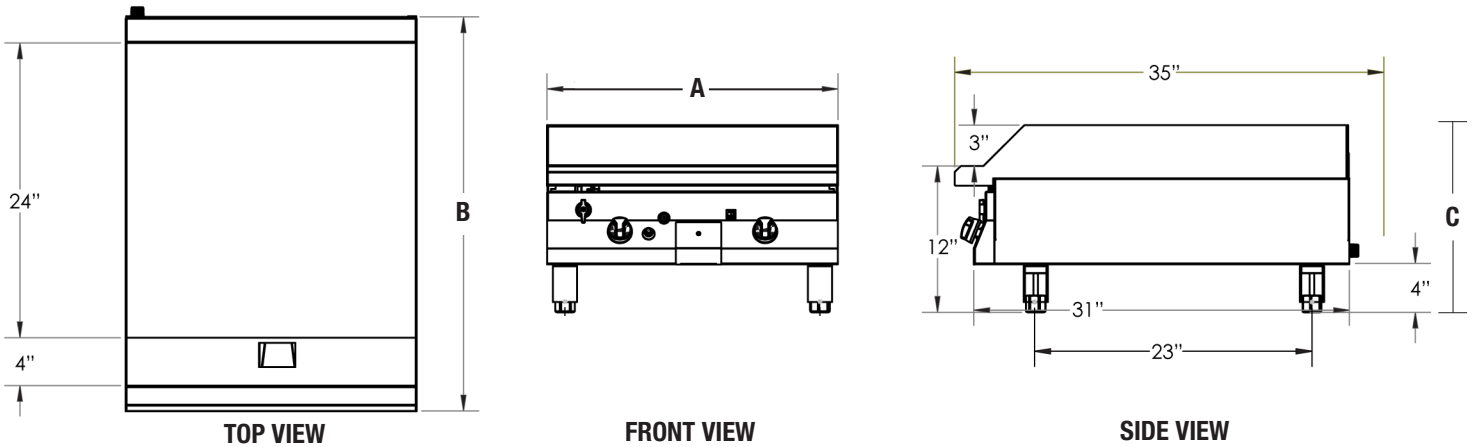

**MECHANICAL SPECIFICATIONS**

Model	Width (A) IN (MM)	Depth (B) IN (MM)	Height (C) IN (MM)	Burners	Cooking Area	Total BTU/HR	Installed Wgt LBS (KG)	Ship Wgt LBS (KG)
<b>VRX-24-MG</b>	24" (609.6)	33" (838.2)	15" (381)	2	24" x 24"	52,000	156 (70.2)	171 (77.0)
<b>VRX-36-MG</b>	36" (914.4)	33" (838.2)	15" (381)	3	36" x 24"	78,000	234 (105.3)	256 (115.2)
<b>VRX-48-MG</b>	48" (1219.2)	33" (838.2)	15" (381)	4	48" x 24"	104,000	322 (144.9)	352 (158.4)
<b>VRX-60-MG</b>	60" (1524)	33" (838.2)	15" (381)	5	60" x 24"	130,000	399 (179.55)	440 (198)

\*These are nominal dimensions and can vary by +1.75" with adjustable legs.

**Freight Class: 85**

**GAS AND ELECTRICAL REQUIREMENTS**

- Manifold pressure for Natural Gas: 5.0 in W.C.
- Manifold pressure for LP Gas: 10.0 in W.C.
- Gas connection: 3/4-inch NPT rear manifold
- Units operate on Natural Gas or Propane Gas; conversion components included
- 120V, 50/60 Hz, 1 Amp single phase with NEMA 5-15 USA plug

**VENTILATION REQUIREMENTS**

- Commercial installation requires a properly engineered ventilation and exhaust system.

For compliance, refer to:

- National Fire Protection Association Standard NFPA 96 (North America Only)

**WARRANTY AND SERVICEABILITY**

- Standard one-year parts and labor warranty from MVP Group

Side	Required Clearance	
	Combustible	Non-Combustible
<b>Left</b>	6"	0"
<b>Right</b>	6"	0"
<b>Back</b>	6"	0"

MVP Group continually works to improve our products. As a result, specifications, features, and designs may be updated or changed without notice. We make every effort to provide accurate information, but occasional variations or errors may occur. Product performance and results will depend on individual use. By relying on this information, you acknowledge that MVP Group is not liable for any differences or outcomes related to its use.

**California Proposition 65 Compliance Notice:**

This product may contain one or more chemical substances, including lead, that are listed by the State of California as known or suspected to cause cancer, birth defects, or other reproductive harm. Operation, handling, installation, or servicing of this product may result in exposure to such substances. For additional regulatory information, refer to [www.p65warnings.ca.gov](http://www.p65warnings.ca.gov)

