



SG44

Double Deck Gas Convection Oven



SELL SHEET

Model SG44
Shown on optional casters



SPECIFIER STATEMENT

Double section gas convection oven, Vulcan Model No. SG44. Stainless steel front, sides, top and legs. Independently operated stainless steel doors with double pane windows. Non-sag insulation applied to the top, rear, sides, bottom and doors. Porcelain enamel on steel oven interiors measures 29"w x 22½"d x 20"h. Two interior oven lights per section. Five nickel plated oven racks per section measure 28¾" x 20½". Eleven position nickel plated rack guides with positive rack stops. One 60,000 BTU/hr. burner per section. 120,000 total BTU/hr. Gentle bake selector switch. Electronic spark igniters. Furnished with a two speed ½ H.P. oven blower-motor per section. Oven cool switch for rapid cool down. Each section equipped with 6' cord and plug. Each section requires 120 volt, 60 Hz, 1 ph power supply providing 7.7 amps draw per section.

Exterior Dimensions:

40¼"w x 40"d (includes motor & door handles)
37¾"d (includes motor only) x 70"h on 8" legs.

CSA design certified. NSF listed.

Specify type of gas when ordering.

Specify altitude when above 2,000 FT.

Project _____

AIA # _____ SIS # _____

Item # _____ Quantity _____ C.S.I. Section 114000

MODELS

- SG44** Solid state temperature controls adjust from 150° to 500°F. 60 minute timer with audible alarm.

Double deck ovens are supplied as separate units with a stacking kit.

STANDARD FEATURES

- 60,000 BTU/hr. burner per section
- Gentle bake mode selector switch
- Solid state temperature controls adjust from 150° to 500°F
- 60 minute timer with audible alarm
- Oven cool switch for rapid cool down
- Electronic spark igniters
- Independently operated stainless steel doors with double pane windows
- Stainless steel front, sides, top and legs
- ½ H.P. two speed oven blower-motor; 120/60/1 with 6' cord and plug; 7.7 amps per section. 15.4 amps total draw
- Porcelain coated enameled steel
- Five nickel plated grab-and-go oven racks with eleven rack positions per section (10 total racks)
- ¾" rear gas connection with combination gas pressure regulator and safety solenoid system
- One year limited parts and labor warranty

OPTIONS

- Casters
- 208V or 240V, 60 Hz, 1 ph, two speed, ½ H.P. blower motor; 208V, 4.2 amps; 240V, 3.6 amps
- Second year extended limited parts and labor warranty

ACCESSORIES (PACKAGED AND SOLD SEPARATELY)

- RACK-1PCNEW** - Extra oven rack(s)
- RACK-HANGRV** - Rack hanger
- DRIPPAN-SSDD** - Stainless steel drip pan
- 3/4QD-HOSE-4** - Flexible gas hose with quick disconnect and restraining device.
- DRAFT-DIVERT** - Down draft flue diverter for direct vent connection
- HTSHLD-LH/V** or **HTSHLD-RH/V** Stainless steel rear enclosure

SG44 – Double Deck Gas Convection Oven

Approved by _____ Date _____ Approved by _____ Date _____

INSTALLATION INSTRUCTIONS

1. A combination gas pressure regulator and safety solenoid system is included in this unit. Natural gas is 5.0" W.C. Propane gas is 10.0" W.C.
2. An adequate ventilation system is required for commercial cooking equipment. Information may be obtained by visiting the National Fire Protection Association website at <https://www.nfpa.org/>. Refer to NFPA No. 96.
3. These units are manufactured for installation in accordance with ANSZ223.1A (latest edition), National Fuel Gas Code. Information may be obtained from The American Gas Association website at <https://www.aga.org/>.
4. Clearances:

	Combustible	Non-combustible
Rear	0"	0"
Right Side	2"	0"
Left Side	1"	0"
5. This appliance is manufactured for commercial installation only and is not intended for home use.
6. The installation location should not experience temperatures below -20°C (-4°F).

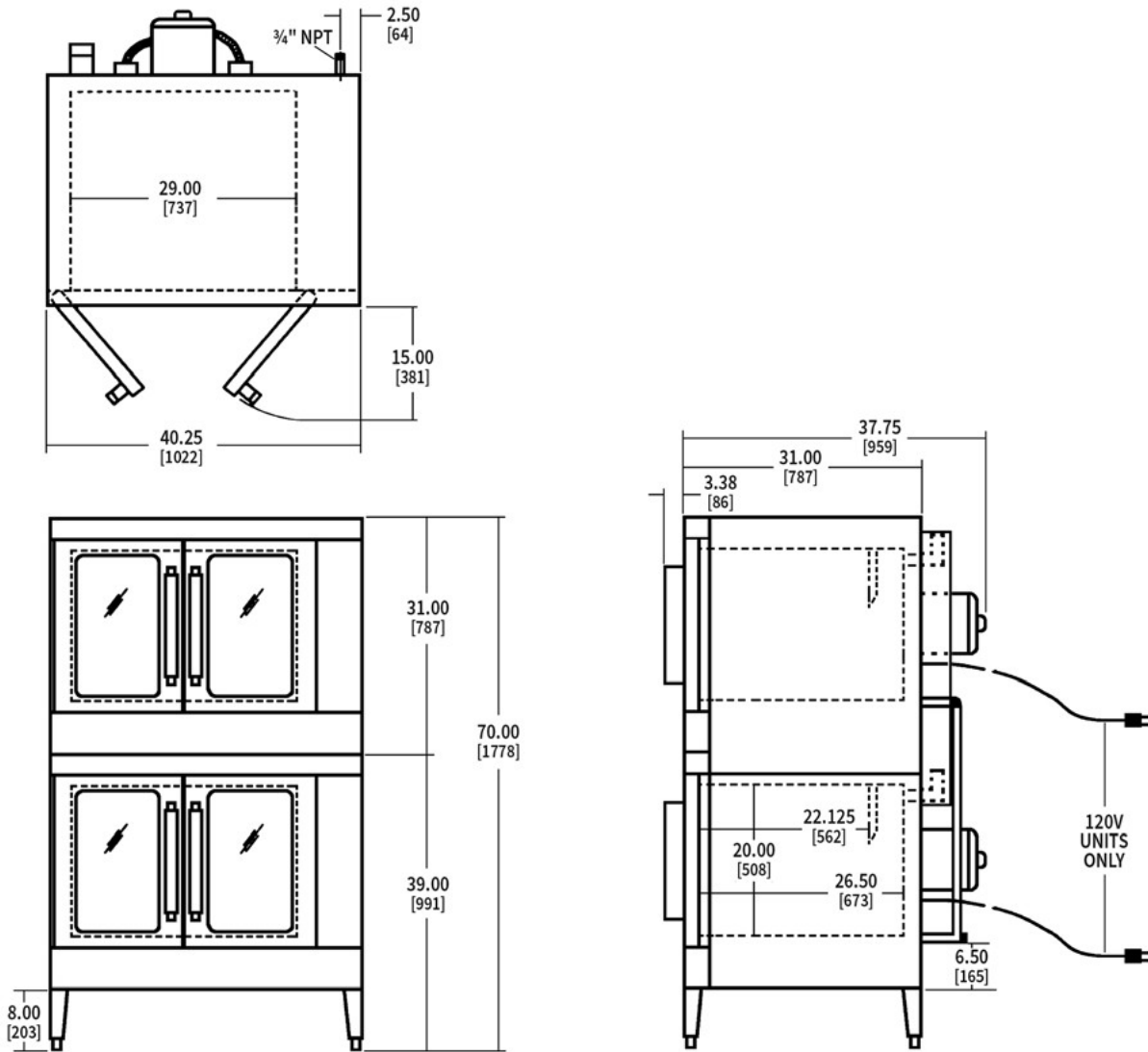

➤ CAD and/or Revit Files Available

Model	Width	Depth (Includes Handles)	Height	BTU/Hr. Per Oven	Total BTU/hr.	Electrical	Weight			
							With Skid & Packaging		Without Skid & Packaging	
							Lbs.	KG	Lbs.	KG
SG44	40 1/4"	40"	70"	60,000	120,000	120/60/1	928	422	820	372

As continued product improvement is a policy of Vulcan, specifications are subject to change without notice.