

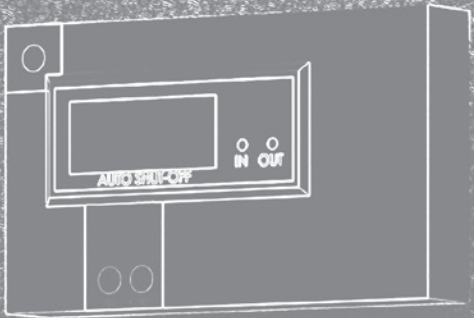

WORKING PRESSURE



PERMEATE PRESSURE



5 MICRON SEDIMENT

10 MICRON CARBON BLOCK

10 MICRON CARBON BLOCK

LP-SERIES

Reverse Osmosis System User Manual

TABLE OF CONTENTS

Safety	1
Operating Do's and Don'ts	1
Operating Limits	2
System Specification Chart	3
Component Identification	4–6
Pre-filtration	7
Component Descriptions	7
Membrane Information	8
Membrane Warranty	9
Membrane Performance	10
System Installation	11–12
Membrane Installation/Replacement	13–14
System Purging/Initial Start Up	15
General Maintenance and Storage	16
Temperature Correction Factors	17
Temperature Correction Table	18
Reverse Osmosis Operating Log	19
Troubleshooting	20
LP-350 / 350 PLUS Flow Diagram	21
LP-500 / 500 PLUS Flow Diagram	22
LP-700 / 700 PLUS Flow Diagram	23
LP-500 / 500 PLUS Wiring Diagram	24
System Warranty	25–26



Your LP-Series Reverse Osmosis System is a durable piece of equipment which, with proper care, will last for many years. This User Manual outlines installation, operation, maintenance and troubleshooting details vital to the sustained performance of your system.

If the feedwater conditions change, please contact your local dealer or distributor.

PLEASE NOTE



- Do not under any circumstances remove any caution, warning, or other descriptive labels from the system.
- Prior to operating or servicing the reverse osmosis system, this user manual must be read and fully understood. Keep this and other associated information near the system for future reference and for new operators or qualified personnel near the system.
- In order to maintain the manufacturer's warranty, an operating log must be maintained. Copies will need to be sent to your local dealer or distributor for review.
- Please read the entire manual before proceeding with the installation and START-UP. Failure to follow instructions or operating parameters may lead to the product's failure, which can cause property damage and/or personal injury.



SAFETY









The Safety section of this User Manual outlines the various safety headings used throughout this manual's text and are enhanced and defined below:

Warning Labels

	Warning: Indicates statements that are used to identify conditions or practices that could result in injury or loss of life. Failure to follow warnings could result in serious injury or even death.
	Caution: Indicates statements that are used to identify conditions or practices that could result in equipment or other property damage.
	Electrical Hazard: Indicates statements that are used to identify high-voltage and potential shock/electrocution.

STATEMENTS IN BOLD AND ALL CAPITALS ARE ADVISORY OR INFORMATIONAL STATEMENTS OF PARTICULAR IMPORTANCE TO THE HEADING UNDER WHICH THEY ARE FOUND.

Precautions

	Do not use where the water is microbiologically unsafe or of unknown quality without adequate disinfection before or after the system.
	Always turn off the unit, shut off the feedwater, relieve pressure, and disconnect the electrical power before working on the unit.
	Do not operate the system with insufficient feed flow. Never allow the pump to run dry.
	Pre-treatment must be sufficient to eliminate chemicals, organics or inorganics that could attack the membrane material.
	Never allow the unit to freeze or operate with a feedwater temperature above 85°F.
	Do not permit chlorine to be present in the feedwater.
	Do not shut down the system for extended periods. It is best to run the system as much as possible on a continuous basis.
	Electrical installation should be done by qualified, trained electricians. Installation should be to local codes.

OPERATING DO'S AND DON'TS

Do:

- Change the cartridge filters regularly.
- Monitor the system and keep a daily log.
- Run the system as much as possible on a continuous basis.
- Adjust the system recovery to the recommended value.
- Always feed the pump with filtered water.

Don't:

- Permit chlorine to enter or be present in the feedwater.
- Shut down the system for extended periods.
- Operate the system with insufficient feed flow or pressure.
- Operate the pump dry.

OPERATING LIMITS

Nothing has a greater effect on a reverse osmosis system than the feedwater quality. If your system is altered at the site of operation or if the feedwater conditions change, please contact your local dealer or distributor to determine the proper recovery for your application. Before starting the RO system it is strongly suggested to obtain an up to date water analysis of the water to be treated.



It is very important to meet the minimum feedwater and operating requirements outlined in this manual. Failure to do so will cause damage or failure of the system components and membranes. Damage to the system due to operation outside of the specifications outlined in this manual will void the manufacturer's warranty. Check your feedwater chemistry and, if necessary, consult with your local dealer or distributor before start up of the system.

OPERATING LIMITS ^A	LP-350 / 350 PLUS	LP-500 / 500 PLUS	LP-700 / 700 PLUS
Design Temperature (°F)	77	77	77
Maximum Feed Temperature (°F)	85	85	85
Minimum Feed Temperature (°F)	50	50	50
Maximum Ambient Temperature (°F)	120	120	120
Minimum Ambient Temperature (°F)	40	40	40
Maximum Feed Pressure (psi)	90	70	90
Minimum Feed Pressure (psi)	70	45	70
Maximum SDI Rating	< 3	< 3	< 3
Maximum Turbidity (NTU)	1	1	1
Maximum Free Chlorine (ppm)	0	0	0
Maximum TDS (ppm)	500	500	500
Maximum Hardness (gpg)	< 1	< 1	< 1
Maximum pH (continuous)	10	10	10
Minimum pH (continuous)	4	4	4

A. If any of the feedwater parameters are not within the limits given, consult your local dealer or distributor for assistance.



Higher TDS and/or lower temperatures will reduce the system's production.



Do not exceed the maximum operating pressure.

SYSTEM SPECIFICATION CHART

MODELS	LP-350 / 350 PLUS	LP-500 / 500 PLUS	LP-700 / 700 PLUS
Design			
Configuration	Single Pass	Single Pass	Single Pass
Feedwater TDS max (ppm)	TDS < 500	TDS < 500	TDS < 500
Standard Recovery %	36	46	36
Flow Rates			
Permeate Flow Rate (gpd / lpd)	350 / 1,324	500 / 1,892	700 / 2,649
Permeate Flow Rate (gpm / lpm)	0.24 / 0.91	0.35 / 1.32	0.48 / 1.81
Minimum Concentrate Flow Rate (gpm)	0.42	0.41	0.84
Connections			
Feed (in)	3/8 QC	3/8 QC	3/8 QC
Permeate (in)	3/8 QC	3/8 QC	3/8 QC
Concentrate (in)	3/8 QC	3/8 QC	3/8 QC
Membranes			
Membrane Quantity	1	1	2
Membrane Size	3012	3012	3012
Nominal TDS Rejection %	98	98	98
Vessels			
Vessel Array	1	1	2 (Parallel)
Vessel Quantity	1	1	2
Pumps			
Pump Type	N/A	Aquatec 5800	N/A
Motor HP	N/A	N/A	N/A
RPM at 60 Hz	N/A	N/A	N/A
System Electrical			
High Voltage Service + Amp Draw	N/A	110V, 1PH, 60Hz, 4A / 220V, 1PH, 50Hz, 4A	N/A
System Dimensions			
Approximate Dimensions ^A L x W x H (in / cm)	12 x 17 x 32 / 30.48 x 43.18 x 81.28	12 x 17 x 32 / 30.48 x 43.18 x 81.28	12 x 17 x 32 / 30.48 x 43.18 x 81.28
Approximate Weight (lbs / kg)	35 / 15.87	41 / 18.60	38 / 17.24

A. Does not include operating space requirements.

Warranty Evaluation Test Conditions: Permeate flow rates and salt rejection based on the following test conditions—550 ppm, filtered and dechlorinated municipal tap water, 77°F / 25°C, 15% recovery, 7.0 pH and the specified operating pressure for membrane element type. Data taken after 60 minutes of operation.

COMPONENT IDENTIFICATION

LP-350 / 350 Plus System

- 1 Cartridge, Carbon Block, 2.5" X 20", 10 MIC (Part #200659)
- 2 Cartridge, Depth Filter, Polypro, 2.5" X 20", 5 MIC (Part #200626)
- 3 Housing, Filter, WHT/WHT, 2.5" X 20", 5 GC O-Ring, NPR, 3/8" FNPT (Part #207295)
- 4 Housing, Membrane, 3012, WHT, Angle 3/8" FNPT, AXEON (Part #208438)
- 5 Membrane, TE, 3012, 500 GPD, DRY, AXEON (Part #211665)
- 6 Meter, TDS, Inline, DM-2, 3/8" QC, HM Digital (Part #210484)
- 7 Gauge, BKM, GLY Fill, 0-100 Psi/Bar, 2.5" DIA, 1/4" MNPT, AXEON (Part #204165)
- 8 Gauge, BKM, GLY Fill, 0-100 Psi/Bar, 2.5" DIA, 1/4" MNPT, AXEON (Part #204165)
- 9 Gauge, BKM, GLY Fill, 0-100 Psi/Bar, 2.5" Dia, SS, 1/4" MNPT, AXEON (Part #205099)
- 10 Valve, Shut Off, Flow Through, White, 3/8" QC, 010258 (Part #211270)
- 11 Valve, Check, Acetal, 3/8" QC X 3/8" QC, JG (Part #200962)

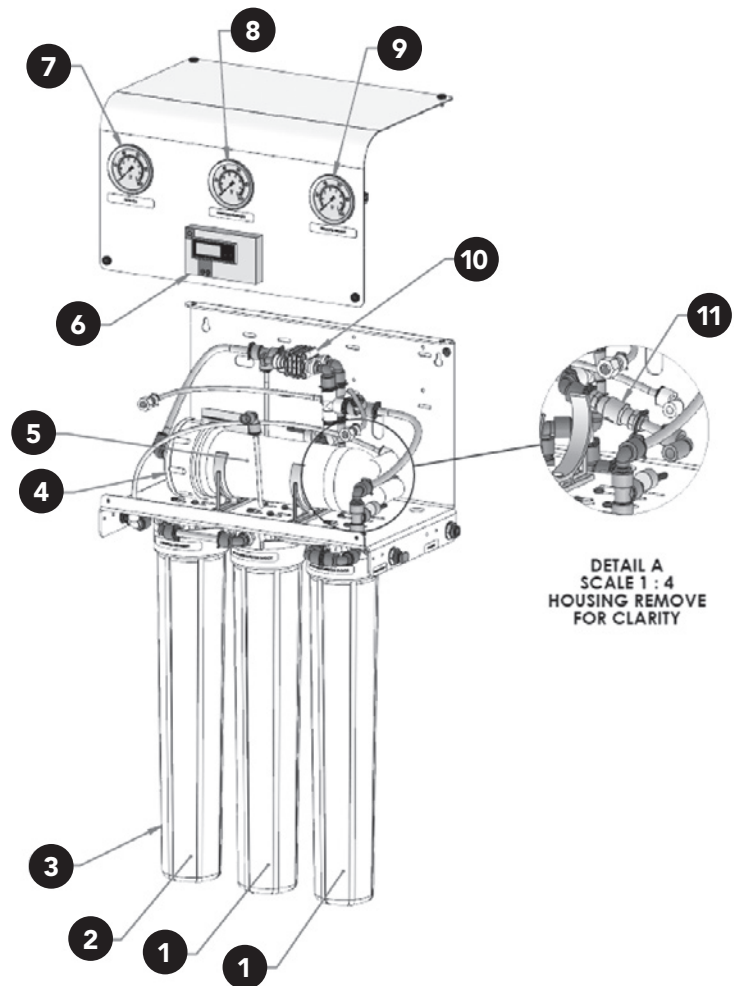

COMPONENT IDENTIFICATION

LP-500 / 500 Plus System

- 1** Cartridge, Carbon Block, 2.5" X 20", 10 MIC (Part #200659)
- 2** Cartridge, Depth Filter, Polypro, 2.5" X 20", 5 MIC (Part #200626)
- 3** Housing, Filter, WHT/WHT, 2.5" X 20", 5 GC O-Ring, NPR, 3/8" FNPT (Part #207295)
- 4** Housing, Membrane, 3012, WHT, Angle 3/8" FNPT, AXEON (Part #208438)
- 5** Membrane, TE, 3012, 500 GPD, DRY, AXEON (Part #211665)
- 6** Meter, TDS, Inline, DM-2, 3/8" QC, HM Digital (Part #210484)
- 7** Gauge, BKM, GLY Fill, 0-100 Psi/Bar, 2.5" DIA, 1/4" MNPT, AXEON (Part #204165)
- 8** Gauge, BKM, Fill, 0-300 Psi/Bar, 2.5" Dia, 1/4" MNPT, AXEON (Part #200904)
- 9** Gauge, BKM, GLY Fill, 0-100 Psi/Bar, 2.5" Dia, SS, 1/4" MNPT, AXEON (Part #205099)
- 10** Valve, Needle, SS 316L, 1/4" FNPT, AXEON, (Part #201004)
- 11** Pump Booster, 5800, 1.0 GPM, 24 Vac 2AMP, Aquatec (Part #207442)
- 12** Transformer, 110V 60Hz 24VAC, 4.0 AMP, TDC (Part #207917)
- 13** Restrictor, Fixed, 800 mL/Min, Auto Flush, 1/4" QC (Part #200772)
- 14** Switch, Tank, Pressure, 40-60 PSI, 3/8" QC, Aquatec (Part #210620)

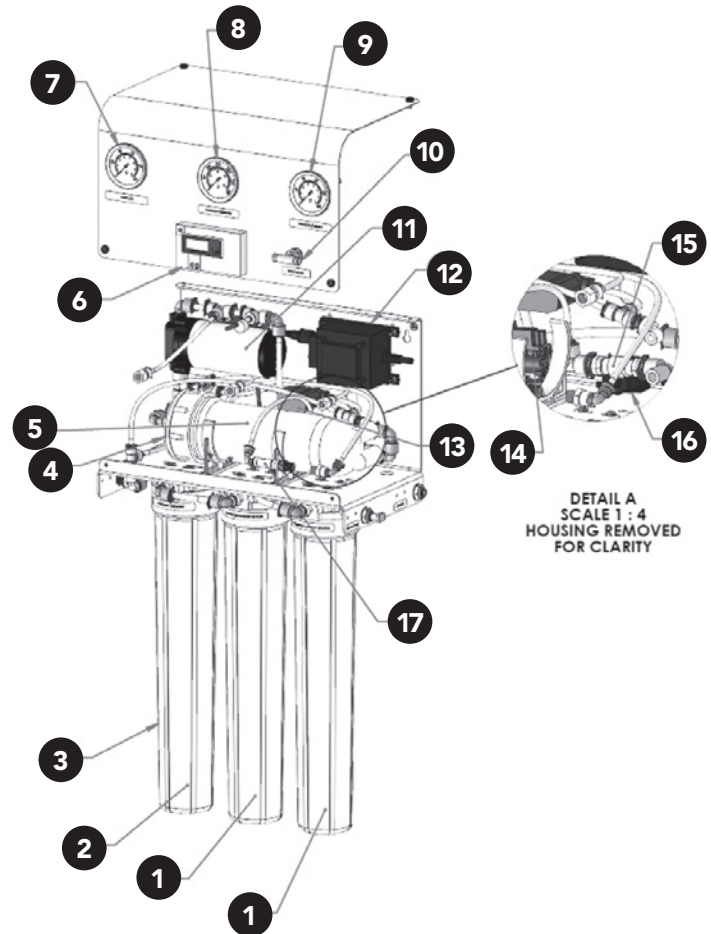

- 15** Valve, Check, Acetal, 3/8" QC X 3/8" QC, JG (Part #200962)
- 16** Valve, Solenoid, 3/8" QC, 24V, Interelektrik (Part #207974)
- 17** Valve, Check, 1/4" QC X 1/4" QC (Part #200961)

COMPONENT IDENTIFICATION

LP-700 / 700 Plus System

- 1 Cartridge, Carbon Block, 2.5" X 20", 10 MIC (Part #200659)
- 2 Cartridge, Depth Filter, Polypro, 2.5" X 20", 5 MIC (Part #200626)
- 3 Housing, Filter, WHT/WHT, 2.5" X 20", 5 GC O-Ring, NPR, 3/8" FNPT (Part #207295)
- 4 Housing, Membrane, 3012, WHT, Angle 3/8" FNPT, AXEON (Part #208438)
- 5 Membrane, TE, 3012, 500 GPD, DRY, AXEON (Part #211665)
- 6 Meter, TDS, Inline, DM-2, 3/8" QC, HM Digital (Part #210484)
- 7 Gauge, BKM, GLY Fill, 0-100 Psi/Bar, 2.5" DIA, 1/4" MNPT, AXEON (Part #204165)
- 8 Gauge, BKM, GLY Fill, 0-100 Psi/Bar, 2.5" DIA, 1/4" MNPT, AXEON (Part #204165)
- 9 Gauge, BKM, GLY Fill, 0-100 Psi/Bar, 2.5" Dia, SS, 1/4" MNPT, AXEON (Part #205099)
- 10 Valve, Check, Acetal, 3/8" QC X 3/8" QC, JG (Part #200962)
- 11 Valve, Shut Off, Flow Through, White, 3/8" QC, 010258 (Part #211270)

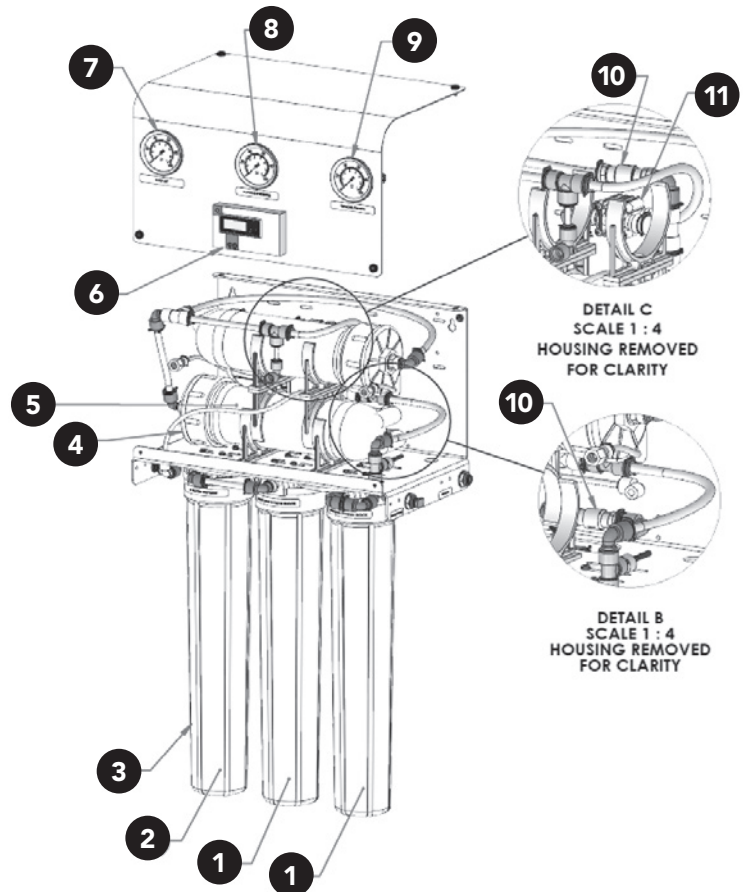

PRE-FILTRATION

LP-Series systems are supplied with a 5-micron sediment filter and a 10-micron carbon block filter. Change the cartridge once a month or when a 10-15 psi differential exists between the feed source pressure and the filter out pressure.

Filter Out, Working Pressure, And Permeate Pressure Gauges

LP-Series systems include pressure gauges for monitoring filter out, working and permeate pressures.



FILTER OUT



COMPONENT DESCRIPTIONS



TE-3012 RO Membrane

The TE-3012 RO membrane utilizes advanced manufacturing processes of the industry's leading film technology allows these elements to deliver consistent results that equipment suppliers and water treatment dealers have come to rely on.



Pump

The LP-500/LP-500PLUS Series systems uses Aquatec's diaphragm booster pump technology, provides the highest quality and most reliable inlet pressure for efficient membrane utilization.



TDS Monitor

LP-Series systems come standard with a dual probe TDS monitor to measure inlet and permeate water quality.

MEMBRANE INFORMATION

The LP-Series Reverse Osmosis Systems are equipped with AXEON TE-Series Membrane Elements. TE-Series Residential Membrane Elements are recognized as one of the industry’s most reliable and highest performing membrane elements that deliver consistent quality and performance. General membrane element performance characteristics are listed below.

TE-SERIES MEMBRANES (STANDARD)—SPECIFICATIONS/OPERATING LIMITS

Membrane Type	Polyamide Thin-Film Composite
Maximum Operating Temperature (°F / °C)	113 / 45
Maximum Operating Pressure (psi / bar)	300 / 20
pH Range (Continuous Operation) ^A	2-11
pH Range (Short Term Cleaning—30 Min.)	2-11
Maximum Feed Silt Density Index (SDI)	5
Chlorine Tolerance	0 ppm
Maximum Feed Flow Rate (gpm / lpm)	2.50 / 9.50

A. Maximum temperature for continuous operations above pH 10 is 95 °F / 35 °C.

PRODUCT SPECIFICATIONS

Part #	Description	Applied Pressure (psi / bar)	Permeate Flow Rate (gpd / lpd)	Nominal Salt Rejection (%)
211665	TE-3012-500	100 / 4.83	500.00 / 1892.71	97

DIMENSIONS (IN / MM)

A	B	C	D	E
11.73 / 298.00	0.85 / 21.50	0.68 / 17.27	2.76 / 70.10	10.04 / 255.00

Warranty Evaluation Test Conditions: Permeate flow and salt rejection based on the following test conditions—250 ppm, filtered and dechlorinated municipal tap water, 77°F / 25°C, 15% recovery and the specified operating pressure. Minimum salt rejection is 96%. Permeate flows for warranty evaluation may vary +/- 20%. Maximum pressure drops at 13 psi / 0.9 bar.

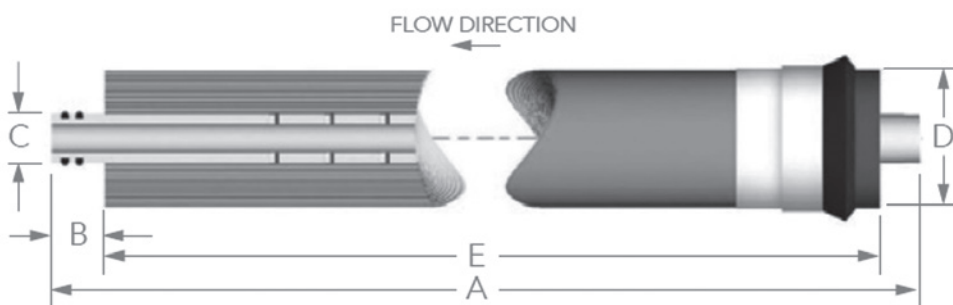

MEMBRANE WARRANTY

Under certain conditions, the presence of free chlorine, chloramines and other oxidizing agents will cause premature membrane failure. Since oxidation damage is not covered under warranty, the manufacturer recommends removing all oxidizing agents by pretreatment prior to membrane exposure. Please contact the manufacturer or your supplier for more information.

It is recommended that systems using these elements rinse the elements for 24 hours, prior to first use, to meet NSF/ANSI 58 Standard. The first full tank of permeate must be discarded. Do not use this initial permeate for drinking water or food preparation. Keep elements moist at all times after initial wetting. To prevent biological growth during prolonged system shutdowns, it is recommended that membrane elements be immersed in M-100 preservative solution. Rinse out the preservative before use. For membrane warranty details, please contact the manufacturer or your supplier for more information.

If operating limits and guidelines given in this product specification sheet are not strictly followed, the warranty will be null and void. The customer is fully responsible for the effects of incompatible chemicals and lubricants on elements. Use of any such chemicals or lubricants will void the warranty. These membranes may be subject to drinking water application restrictions in some countries: please check the application status before use and sale. These elements have not been through the French approval process for use in potable water. The use of this product in and of itself does not necessarily guarantee the removal of cysts and pathogens from water. Effective cyst and pathogen reduction is dependent on the complete system design and on the operation and maintenance of the system.

No freedom from infringement of any patent owned by the manufacturer or others is to be inferred. Because use conditions and applicable laws may differ from one location to another and may change with time, customer is responsible for determining whether products and the information in this document are appropriate for customer's use and for ensuring that customer's workplace and disposal practices are in compliance with applicable laws and other governmental enactments. The claims made may not have been approved for use in all countries. The manufacturer assumes no obligation or liability for the information in this document. AXEON reserves the right to update this information periodically for the purposes of quality and accuracy.

NO WARRANTIES ARE GIVEN; ALL IMPLIED WARRANTIES OF MERCHANTABILITY OR FITNESS FOR A PARTICULAR PURPOSE ARE EXPRESSLY EXCLUDED.

MEMBRANE PERFORMANCE

LP-Series Reverse Osmosis Systems are designed to produce up to 700 GPD at 77°F (nominal) of permeate water per membrane at 98% rejection under the proper conditions. For example, the LP-700 produces 700 gallons per day of permeate water at the listed operating test conditions.

Rejection

The amount of total dissolved solids (TDS) rejected by the membrane is expressed as a percentage. LP-Series reverse osmosis systems are designed to reject up to 98% NaCl depending on feedwater chemistry. A 98% rejection rate means that 98% of total dissolved solids do not pass through the membrane. To calculate the percent of rejection, use the following formula:

FORMULA	$\frac{\text{Feed TDS} - \text{Permeate TDS}}{\text{Feed TDS}}$	x	100	=	% Rejection
EXAMPLE	$\frac{430 \text{ TDS} - 8.6 \text{ TDS}}{430 \text{ TDS}}$	x	100	=	98% Rejection

Recovery

The amount of permeate water recovered for use is expressed as a percentage. To calculate percent of recovery, use the following formula:

FORMULA	$\frac{\text{Product Water Flow Rate}}{\text{Feed Water Flow Rate}}$	x	100	=	% Recovery
EXAMPLE	$\frac{5.55 \text{ GPM}}{8.55 \text{ GPM}}$	x	100	=	65% Recovery



All flow rates must be expressed in the same units, typically gallons per minute (gpm).

SYSTEM INSTALLATION

Mounting

The free standing system should be bolted down or securely fastened in compliance with local regulation standards.

Plumbing

The membranes and high pressure pumps used on LP-500 / 500 PLUS systems require a continuous flow of water with a minimum feed pressure of 45 psi. Be certain that all of the components of the feedwater are soluble at the concentrations attained in the system.

- Inspect the system for any damage that could have occurred during shipment. Although the system has been individually inspected, complete a quick inspection of the fittings, tubing and other components.
- Please provide a reasonable amount of space for installation and leave six inches of space below the filter housings for ease of maintenance.



The reverse osmosis system should be installed in an area that is not in direct sunlight or extreme cold.

Feed Water Connection

Connect a 3/8" tube from an incoming water source to the 3/8" QC bulkhead labeled "FEED". Best practice to use a 1/2" tubing for the feed and reduce to 3/8" tubing near the incoming 3/8" feed bulkhead.

Concentrate Connection

Connect 3/8" tubing from the 3/8" QC bulkhead labeled "CONCENTRATE" to drain (waste). Run the concentrate line to an open drain in a free and unrestricted manner (no backpressure).

Note: The LP-500 / 500 Plus system has been designed with an auto-flush restrictor. This restrictor automatically flushes the reverse osmosis system for 15-20 seconds every time it starts up and once every hour when the system is producing water.



Do not operate at a pressure exceeding 100 psi.

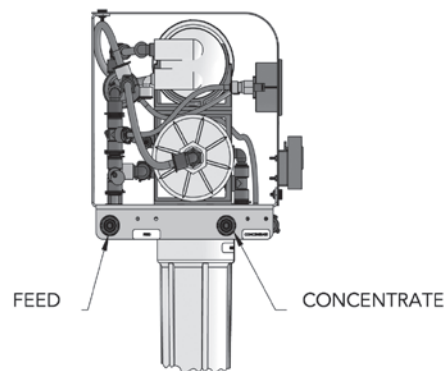

Holding Tank Connection

This system has been designed to operate together with an external bladder tank. Connect 3/8" tubing from the 3/8" QC bulkhead labeled "HOLDING TANK" to permeate storage tank.

Note: The permeate water must be directed to drain for the first 30 minutes of use. Do not fill storage tank until the system has been flushed for 30 minutes.

The tank high pressure switch will shut the system off automatically when the bladder tank is full

Permeate Connection

Connect 3/8" tubing from the 3/8" QC bulkhead labeled "PERMEATE" to the final point-of-use (i.e. faucet). Ensure that the permeate water can flow freely with no backpressure. Backpressure can cause irreversible damage to the membrane elements.

The pH of the permeate water will typically be 1 or 2 pH units lower than the feedwater pH. A low pH can be very aggressive to some plumbing materials such as copper piping.



Any restrictions or blockage in the drain line can cause backpressure, which will increase the system's operating pressure. This can result in damage to the system's membranes and components.

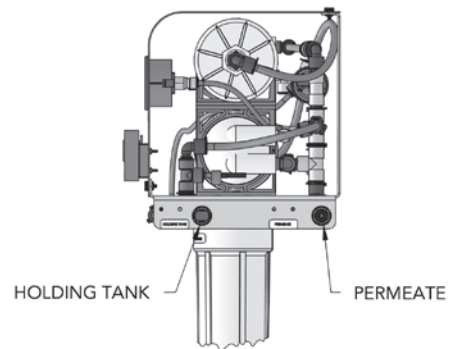

Electrical

Ensure that the electrical circuit supplying the system is compatible with the requirements of the specific LP-Series model you are installing.

MEMBRANE INSTALLATION/REPLACEMENT

Installation and replacing membranes in the pressure vessels is an easy process if you have the proper information and tools at hand. Please refer to the following instructions when removing and replacing membrane elements:



All pressure gauges must read zero before beginning this procedure. Turn the system off, disconnect the power, and bleed all water pressure from the system.

1. Disconnect the tubing from the pressure vessel end cap. Unthread the end cap by turning it counter-clockwise
2. Remove the replacement membrane element(s) from the shipping box; the membrane(s) should be contained within a plastic bag.



Wear gloves for the following steps in order not to contaminate the membrane.

3. Cut the bag open as close as possible to the seal at the end of the bag, so the bag may be re-used if necessary.
4. Make sure that all parts are clean and free from dirt. Examine the brine seal and permeate tube for nicks or cuts. Replace the O-rings or brine seal if damaged.
5. Flow directions should be observed for installation of each element into their respective pressure vessels.



The brine seal must be in the correct position for each pressure vessel. The brine seal is a rubber seal that protrudes on one side of the membrane. For LP Series reverse osmosis systems the brine seal should be on the same side as the pressure vessel end cap.

6. Remove one membrane at a time from the pressure vessels. Long nose pliers may be necessary to pull the old membrane out of the pressure vessel.
7. Lubricate the brine seal and O-rings with a non-petroleum based lubricant, such as Dow Corning® 111. Do not use a petroleum-based lubricant.
8. Install membranes with brine seal location depicted in page (system purging).
9. With a smooth and constant motion, push the membrane element into the housing so the brine seal enters the housing without coming out of the brine seal groove.
10. Re-install the end cap by twisting in a clockwise direction until firmly tightened. Ensure that you do not pinch or fatigue any O-rings while re-installing the end cap(s).
11. Reconnect any fittings that may have been disconnected when the pressure vessels were disassembled.
12. To start-up the system, please refer to the Initial Start-Up section of this User Manual.

MEMBRANE INSTALLATION/REPLACEMENT

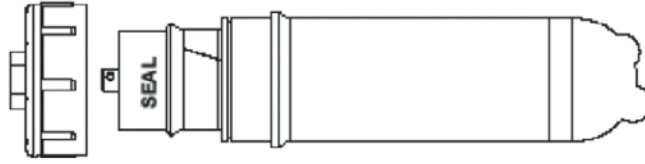

LP, 350 / 350 PLUS

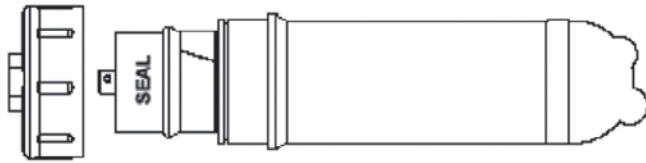

LP, 500 / 500 PLUS

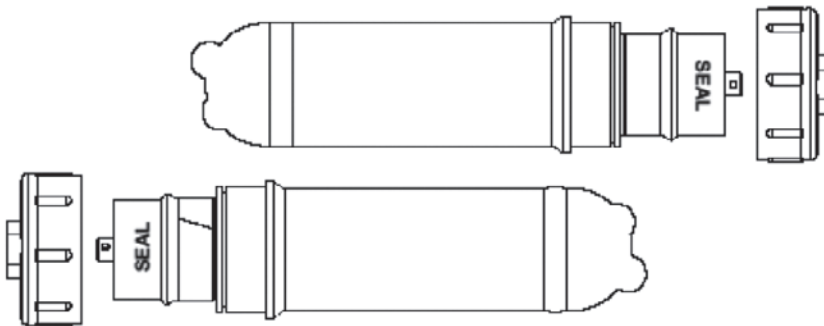

LP, 700 / 700 PLUS

SYSTEM PURGING/INITIAL START-UP

LP-350 and LP-700 Systems

Direct the permeate water line to drain.

1. Turn feed source on with a recommended water pressure of 70-90 psi.
2. Run system while permeate and concentrate lines feed to the drain for 30 minutes to flush out preservative and any trapped air.
3. After 30 minutes, shut down the system and re-direct the permeate line back to final use location (i.e. faucet).
4. Your start up is now complete. Make sure that the system pressures and flows are matching up with that of your specific system model, located on the System Specification (Page 10) of this manual. Record the readings daily for a week and after a week record the readings once a week. This will assist you to determine when component maintenance and/or replacement is necessary.

LP-500 Systems

Direct the permeate water line to drain.



1. Turn feed source on with a recommended minimum pressure of 45 psi.
2. Plug system into proper electrical outlet.
3. Run system while permeate and concentrate lines feed to the drain for 30 minutes to flush out preservative and any trapped air.
4. After 30 minutes, shut down the system and re-direct the permeate line back to final use location (i.e. faucet)

Your start up is now complete. Make sure that the system pressures and flows are matching up with that of your specific system model, located on the System Specification (page 3) of this manual. Record the readings daily for a week and after a week record the readings once a week. This will assist you to determine when component maintenance and/or replacement is necessary.

SYSTEM STORAGE

Preparing the Unit for Storage

If the system is to be shut down for an extended period, a membrane preservative should be used to preserve the membranes.

	<p>Prior to storing your system, the system should be cleaned with AXEON C-10 and C-20 cleaners, flushed with permeate water and M-100 solution for membranes to protect it from biological attack.</p>
	<p>The pressure vessels and plumbing lines of the system must be completely drained or filled with 10-40% propylene glycol mix (to prevent freezing). Any water remaining in the plumbing of a system may freeze, causing serious damage.</p>

1. Completely immerse the elements in the membrane housings using 2% M-100 solution^A.
2. Separate the preservative solution from the air outside by closing all valves. Any contact with oxygen will oxidize the M-100 solution.
3. Check the pH once a week. When the pH becomes 3 or lower, change the preservation solution.
4. Repeat this process at least once a month.

A. For cold weather/winter storage add 20-40% by weight Propylene Glycol to the 2% M-100 solution. Add Propylene Glycol **AFTER** the 2% M-100 solution has been mixed. Refer to the chart below for the weight percent to be added.

FREEZING POINT DEPRESSION OF PROPYLENE GLYCOL SOLUTION BY % WEIGHT

Freezing Point (°F)	26	18	7	-8
Propylene Glycol %	10	20	30	40

EXAMPLE

If the lowest temperature the system would experience in storage is 15 °F, it would be advisable to mix a 30% by weight solution of Propylene Glycol in your 2% M-100 preservative solution. The 30% solution will prevent freezing at temperatures down to 7 °F.

TEMPERATURE CORRECTION FACTORS

A membrane's stated permeate production rate is based on a water temperature of 77°F degrees Fahrenheit. Temperatures above or below 77°F will increase or decrease the membrane's production rate.

Find the temperature correction factor (TCF) for your water temperature on the table located on the next page. Divide the rated permeate flow by the temperature correction factor. The result is the nominal permeate flow rate the system should achieve at actual water temperature. Permeate flow should be within 20% of the rated production, after correcting the feedwater temperatures above or below 77°F. Check your permeate flow meter to determine the permeate flow rate.

EXAMPLE

5 GPM at 59 °F

→

$$\frac{5 \text{ GPM}}{1.422}$$

=

3.52 GPM

EXAMPLE

5 GPM at 77 °F

→

$$\frac{5 \text{ GPM}}{1}$$

=

5 GPM

EXAMPLE

5 GPM at 84 °F

→

$$\frac{5 \text{ GPM}}{.892}$$

=

5.62 GPM

TEMPERATURE CORRECTION TABLE

Temp °F (°C)	TCF	Temp °F (°C)	TCF	Temp °F (°C)	TCF	Temp °F (°C)	TCF	Temp °F (°C)	TCF
50.0 (10.0)	1.711	57.2 (14.0)	1.475	64.4 (18.0)	1.276	71.6 (22.0)	1.109	78.8 (26.0)	0.971
50.2 (10.1)	1.705	57.4 (14.1)	1.469	64.6 (18.1)	1.272	71.8 (22.1)	1.105	79.0 (26.1)	0.968
50.4 (10.2)	1.698	57.6 (14.2)	1.464	64.8 (18.2)	1.267	72.0 (22.2)	1.101	79.2 (26.2)	0.965
50.5 (10.3)	1.692	57.7 (14.3)	1.459	64.9 (18.3)	1.262	72.1 (22.3)	1.097	79.3 (26.3)	0.962
50.7 (10.4)	1.686	57.9 (14.4)	1.453	65.1 (18.4)	1.258	72.3 (22.4)	1.093	79.5 (26.4)	0.959
50.9 (10.5)	1.679	58.1 (14.5)	1.448	65.3 (18.5)	1.254	72.5 (22.5)	1.090	79.7 (26.5)	0.957
51.1 (10.6)	1.673	58.3 (14.6)	1.443	65.5 (18.6)	1.249	72.7 (22.6)	1.086	79.9 (26.6)	0.954
51.3 (10.7)	1.667	58.5 (14.7)	1.437	65.7 (18.7)	1.245	72.9 (22.7)	1.082	80.1 (26.7)	0.951
51.4 (10.8)	1.660	58.6 (14.8)	1.432	65.8 (18.8)	1.240	73.0 (22.8)	1.078	80.2 (26.8)	0.948
51.6 (10.9)	1.654	58.8 (14.9)	1.427	66.0 (18.9)	1.236	73.2 (22.9)	1.075	80.4 (26.9)	0.945
51.8 (11.0)	1.648	59.0 (15.0)	1.422	66.2 (19.0)	1.232	73.4 (23.0)	1.071	80.6 (27.0)	0.943
52.0 (11.1)	1.642	59.2 (15.1)	1.417	66.4 (19.1)	1.227	73.6 (23.1)	1.067	80.8 (27.1)	0.940
52.2 (11.2)	1.636	59.4 (15.2)	1.411	66.6 (19.2)	1.223	73.8 (23.2)	1.064	81.0 (27.2)	0.937
52.3 (11.3)	1.630	59.5 (15.3)	1.406	66.7 (19.3)	1.219	73.9 (23.3)	1.060	81.1 (27.3)	0.934
52.5 (11.4)	1.624	59.7 (15.4)	1.401	66.9 (19.4)	1.214	74.1 (23.4)	1.056	81.3 (27.4)	0.932
52.7 (11.5)	1.618	59.9 (15.5)	1.396	67.1 (19.5)	1.210	74.3 (23.5)	1.053	81.5 (27.5)	0.929
52.9 (11.6)	1.611	60.1 (15.6)	1.391	67.3 (19.6)	1.206	74.5 (23.6)	1.049	81.7 (27.6)	0.926
53.1 (11.7)	1.605	60.3 (15.7)	1.386	67.5 (19.7)	1.201	74.7 (23.7)	1.045	81.9 (27.7)	0.924
53.2 (11.8)	1.600	60.4 (15.8)	1.381	67.6 (19.8)	1.197	74.8 (23.8)	1.042	82.0 (27.8)	0.921
53.4 (11.9)	1.594	60.6 (15.9)	1.376	67.8 (19.9)	1.193	75.0 (23.9)	1.038	82.2 (27.9)	0.918
53.6 (12.0)	1.588	60.8 (16.0)	1.371	68.0 (20.0)	1.189	75.2 (24.0)	1.035	82.4 (28.0)	0.915
53.8 (12.1)	1.582	61.0 (16.1)	1.366	68.2 (20.1)	1.185	75.4 (24.1)	1.031	82.6 (28.1)	0.913
54.0 (12.2)	1.576	61.2 (16.2)	1.361	68.4 (20.2)	1.180	75.6 (24.2)	1.028	82.8 (28.2)	0.910
54.1 (12.3)	1.570	61.3 (16.3)	1.356	68.5 (20.3)	1.176	75.7 (24.3)	1.024	82.9 (28.3)	0.908
54.3 (12.4)	1.564	61.5 (16.4)	1.351	68.7 (20.4)	1.172	75.9 (24.4)	1.021	83.1 (28.4)	0.905
54.5 (12.5)	1.558	61.7 (16.5)	1.347	68.9 (20.5)	1.168	76.1 (24.5)	1.017	83.3 (28.5)	0.902
54.7 (12.6)	1.553	61.9 (16.6)	1.342	69.1 (20.6)	1.164	76.3 (24.6)	1.014	83.5 (28.6)	0.900
54.9 (12.7)	1.547	62.1 (16.7)	1.337	69.3 (20.7)	1.160	76.5 (24.7)	1.010	83.7 (28.7)	0.897
55.0 (12.8)	1.541	62.2 (16.8)	1.332	69.4 (20.8)	1.156	76.6 (24.8)	1.007	83.8 (28.8)	0.894
55.2 (12.9)	1.536	62.4 (16.9)	1.327	69.6 (20.9)	1.152	76.8 (24.9)	1.003	84.0 (28.9)	0.892
55.4 (13.0)	1.530	62.6 (17.0)	1.323	69.8 (21.0)	1.148	77.0 (25.0)	1.000	84.2 (29.0)	0.889
55.6 (13.1)	1.524	62.8 (17.1)	1.318	70.0 (21.1)	1.144	77.2 (25.1)	0.997	84.4 (29.1)	0.887
55.8 (13.2)	1.519	63.0 (17.2)	1.313	70.2 (21.2)	1.140	77.4 (25.2)	0.994	84.6 (29.2)	0.884
55.9 (13.3)	1.513	63.1 (17.3)	1.308	70.3 (21.3)	1.136	77.5 (25.3)	0.991	84.7 (29.3)	0.882
56.1 (13.4)	1.508	63.3 (17.4)	1.304	70.5 (21.4)	1.132	77.7 (25.4)	0.988	84.9 (29.4)	0.879
56.3 (13.5)	1.502	63.5 (17.5)	1.299	70.7 (21.5)	1.128	77.9 (25.5)	0.985	85.1 (29.5)	0.877
56.5 (13.6)	1.496	63.7 (17.6)	1.294	70.9 (21.6)	1.124	78.1 (25.6)	0.982	85.3 (29.6)	0.874
56.7 (13.7)	1.491	63.9 (17.7)	1.290	71.1 (21.7)	1.120	78.3 (25.7)	0.979	85.5 (29.7)	0.871
56.8 (13.8)	1.486	64.0 (17.8)	1.285	71.2 (21.8)	1.116	78.4 (25.8)	0.977	85.6 (29.8)	0.869
57.0 (13.9)	1.480	64.2 (17.9)	1.281	71.4 (21.9)	1.112	78.6 (25.9)	0.974	85.8 (29.9)	0.866

°F=(°C x 9/5) + 32

Corrected Flow Rate= (Measured Flow Rate) * (TCF @ Feed Water Temp.)

REVERSE OSMOSIS OPERATING LOG

Company Name _____

Day of Start Up _____

Location _____

Date of Last Cleaning _____

Week Of _____

System Serial No. _____

Date					
Time					
Hour of Operation					
Filter Inlet Pressure (psi)					
Filter Outlet Pressure (psi)					
Pump Discharge Pressure (psi)					
Concentrate Pressure (psi)					
Feed Flow (gpm)					
Permeate Flow (gpm)					
Concentrate Flow (gpm)					
Recycle Flow (gpm)					
Recovery %					
Feed Temperature					
Feed TDS (ppm)					
Permeate TDS (ppm)					
Rejection %					
Feed pH					
Permeate pH					
Scale Inhibitor Feed (ppm)					
Iron (mg / L)					
Free Chlorine (mg / L)					
Hardness (gpg CaCO₃)					

TROUBLESHOOTING

SYMPTOM	POSSIBLE CAUSES	CORRECTIVE ACTION
Low inlet pressure	Low supply pressure	→ Increase inlet pressure
	Cartridge filters plugged	→ Change filters
	Solenoid valve malfunction	→ Replace solenoid valve (LP-500/500 Plus)
	Leaks	→ Fix any visible leaks
Low permeate flow	Low operating pressure	→ See low inlet pressure
	Low inlet flow	→ Inspect flow restrictor, clean or replace if necessary
	Cold feedwater	→ See temperature correction sheet
	Defective membrane brine seal	→ Inspect and/or replace brine seal
	Fouled or scaled membranes	→ Clean membranes/replace
High permeate flow	Exceeding maximum feedwater temperature	→ See temperature correction sheet
	Damaged or oxidized membrane	→ Replace membrane
	Damage product tube O-rings	→ Inspect and/or replace
Poor permeate quality	Damaged or oxidized membrane	→ Replace membrane
	Damage product tube O-rings	→ Inspect and/or replace
	Low operating pressure	→ See low inlet pressure
Membrane fouling	Scaling (CaSO_4 , CaSO_3 , BaSO_4 , SiO_2)	→ Increase acid addition and antiscalant dosage for CaCO_3 and CaSO_4 ; reduce recovery; clean with acid cleaners
	Biological fouling	→ Shock dosage of sodium bi-sulfate; continuous feed of sodium bi-sulfate at reduced pH; chlorination and de-chlorination; replace cartridge filters
	Organic fouling	→ Activated carbon or other pretreatment; clean with high pH cleaner.
	Metal oxide fouling	→ Improve pretreatment to remove metals. Clean with acid cleaners.
	Colloidal fouling	→ Optimize pretreatment for colloid removal. Clean with high pH anionic cleaners
	Abrasion of membrane by crystalline material	→ Improve pretreatment; check all filters for media leakage

If technical assistance is required, contact your local dealer or distributor. Prior to making the call, have the following information available: system installation date, serial number, daily log sheets, current operating parameters (e.g. flow, operating pressures, pH, etc.), and a detailed description of the problem.

LP-350 / 350 PLUS FLOW DIAGRAM

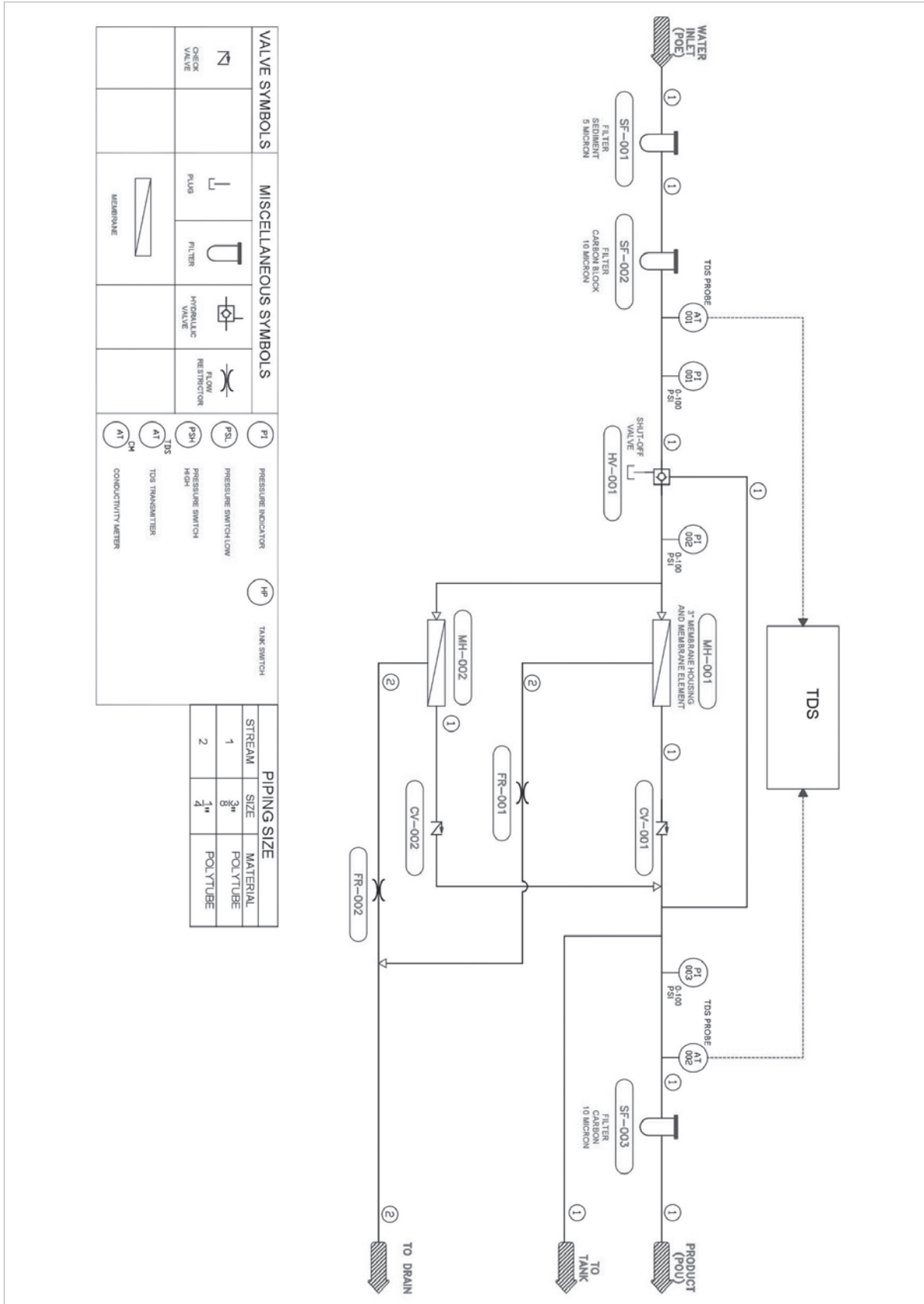

VALVE SYMBOLS	MISCELLANEOUS SYMBOLS	PI	PSL	PSH	TDS	CH	AT

PIPING SIZE		
STREAM	SIZE	MATERIAL
1	3"	POLYTUBE
2	1"	POLYTUBE

LP-500 / 500 PLUS FLOW DIAGRAM

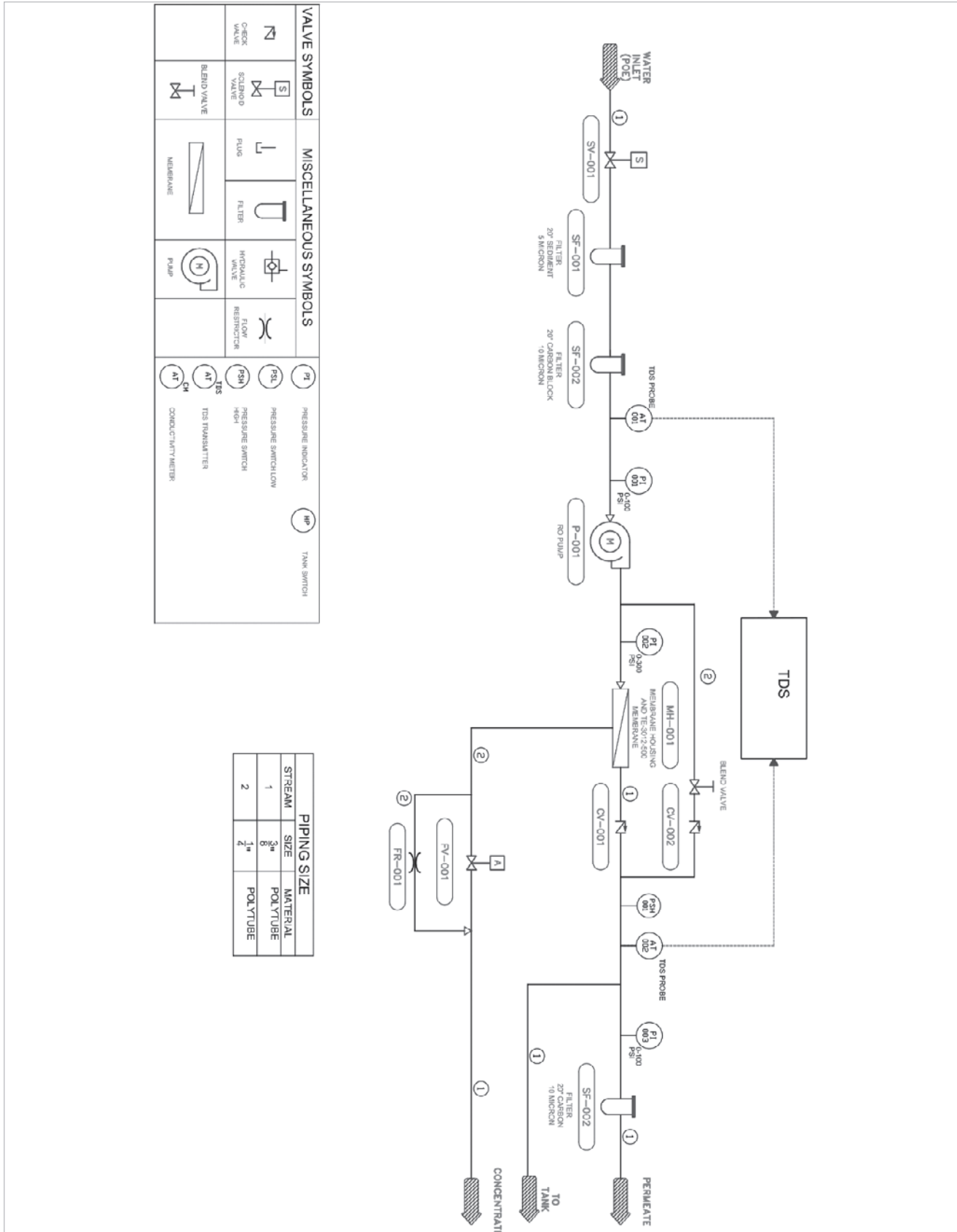

VALVE SYMBOLS		MISCELLANEOUS SYMBOLS		MISCELLANEOUS SYMBOLS	
	CHECK VALVE		BLEND VALVE		MEMBRANE
	SERVICE VALVE		PLUG		FILTER
	HYDRAULIC VALVE		FLOW RESTRICTOR		MEMBRANE PUMP
	PRESSURE INDICATOR		TANK SWITCH		PRESSURE SWITCH LOW
	PRESSURE SWITCH HIGH		TDS TRANSMITTER		CONDUCTIVITY METER

PIPING SIZE		
STREAM	SIZE	MATERIAL
1	3/4"	POLYBUTYLENE
2	1/2"	POLYBUTYLENE

LP-500 / 500 PLUS WIRING DIAGRAM

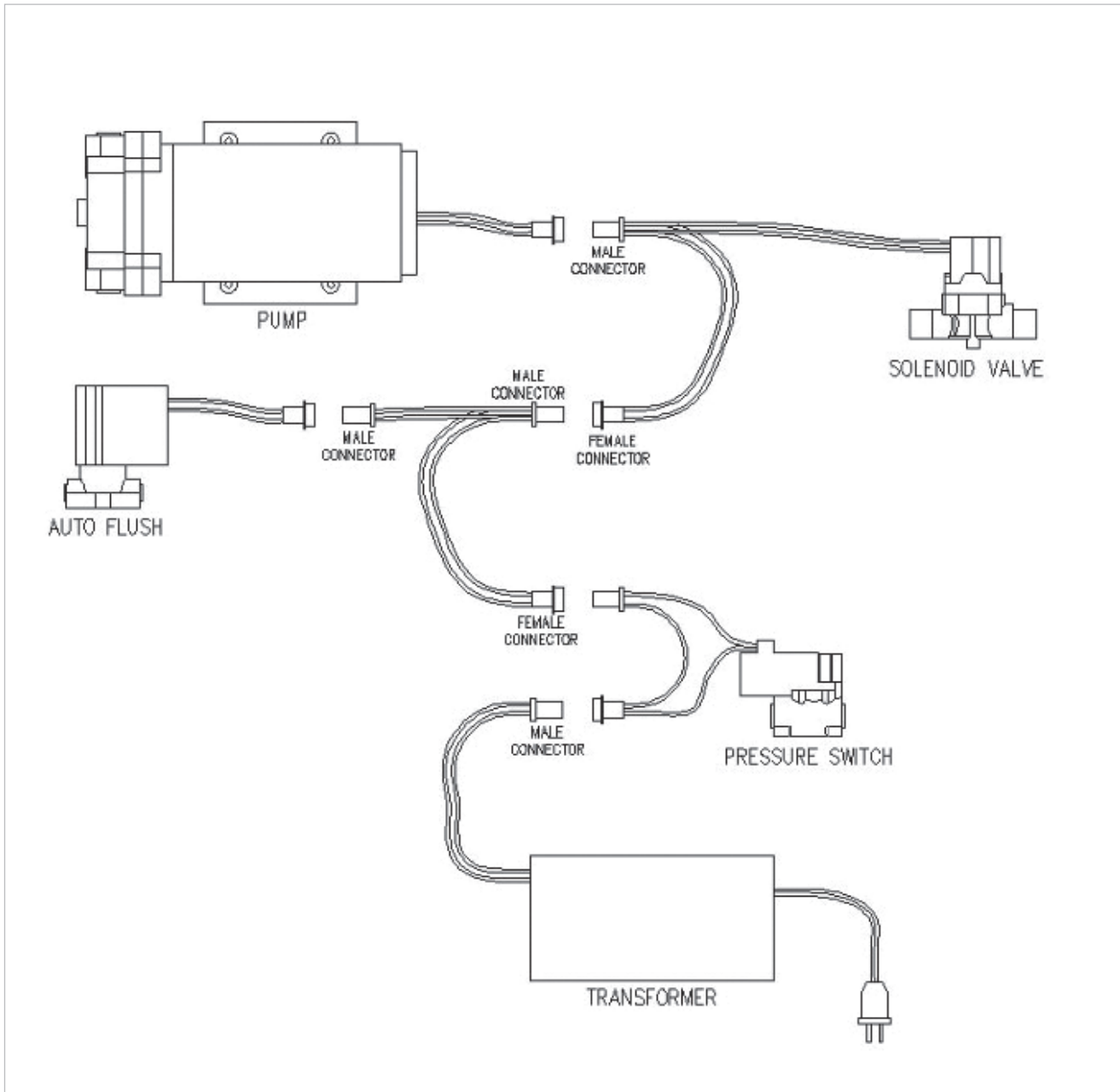

SYSTEM WARRANTY

Warranty Terms

Subject to the terms and conditions set forth hereinafter, the manufacturer (hereafter "Manufacturer") warrants to the original purchaser (hereafter the "Customer") that the systems and products manufactured by the Manufacturer are free from defects in material and in workmanship for twelve (12) months from the Warranty Commencement Date (as defined below) only when used strictly in accordance with the applicable operating instructions and within the range of the operating conditions specified by the Manufacturer for each such product.

This Warranty does not extend to systems, equipment, or components manufactured by others, nor to systems, equipment, or components manufactured by others and distributed by the Manufacturer. This Warranty does not extend to equipment or components manufactured by others which have been incorporated into a Manufacturer product but, if allowable the, Manufacturer hereby assigns, without warranty, to the Customer its interest, if any, under any Warranty made by the Manufacturer of such equipment or component. This Warranty does not cover disposable items such as fuses, O-rings, regeneration materials/chemicals, or other such disposable items, which must be replaced periodically under the normal and foreseeable operating conditions of the goods warranted hereby.

Warranty Commencement Date

The Warranty Commencement Date for each Manufacturer product shall be the later of the date of: (1) receipt by the Customer, or (2) the date of installation at the Customer's premises provided that such installation must occur within three (3) months of shipment from the Manufacturer's manufacturing facility. In no event shall the Warranty Commencement Date exceed three (3) months from the shipment from the Manufacturer's manufacturing facility. The Customer shall provide proof of purchase in order to exercise rights granted under this Warranty. If requested by the Manufacturer, the Customer must also provide proof of the installation date.

Warranty Service

THE MANUFACTURER'S OBLIGATION UNDER THIS WARRANTY IS LIMITED TO THE REPAIR OR REPLACEMENT (AT MANUFACTURER'S SOLE DISCRETION) OF ANY PRODUCT, OR COMPONENT THEREOF, PROVED TO BE DEFECTIVE IN MATERIAL OR WORKMANSHIP WITHIN THE COVERED WARRANTY PERIOD.

The Customer, at the Customer's risk and expense, shall be responsible for returning such product or component, only after obtaining a Return Goods Authorization (RGA) number from the Manufacturer, arranging for freight prepaid, and in conformance with any special packaging and shipping instructions set forth on the operation documentation or RGA instructions, or as otherwise reasonably required, to the Manufacturer, together with (1) RGA number issued by the Manufacturer at Customer's request; (2) proof of purchase and, if necessary, proof of installation date; (3) a Return Goods Authorization Form; (4) a description of the suspected defects; (5) the serial number of the Manufacturer product alleged to be defective; (6) a description of the type of water and pretreatment equipment which has been utilized in connection with the product, if any. The Manufacturer shall, in the Manufacturer's reasonable discretion, be the sole judge of whether a returned product or component is defective in material or workmanship. Required or replaced products or components shall be returned surface freight.

In genuine emergency situations, the Manufacturer will (at the Manufacturer's sole discretion) forward replacement parts to the Customer without waiting for authorized return of the questionable part(s). In such cases, Customer will issue a purchase order or other payment guarantee prior to shipment. If the returned part is found to have been misused or abused, or the defective part is not received by the Manufacturer within thirty (30) days; the Customer will be invoiced for the replacement part(s) provided. This Warranty does not cover or include labor and/or travel to the Customer's premise or location or any other location. Charges of \$2500 per day plus associated travel expenses will be incurred by the Customer in providing the Warranty Service at any location other than the Manufacturer's main headquarters; that is if the Manufacturer deems that the product is not covered by said Warranty. The Manufacturer reserves the right to precondition such travel to Customer's premises upon prepayment of the Manufacturer's anticipated costs of attending such premises.

Voidability of Warranty

This Warranty shall be void and unenforceable as to any Manufacturer product which has been damaged by accident, mishandling, abuse or has been repaired, modified, altered, disassembled or otherwise tampered with by anyone other than the Manufacturer or an authorized Manufacturer service representative; or, if any replacement parts are not authorized by the Manufacturer have been used, or, the product has not been installed, operated and maintained in strict accordance and adherence with the operating documentation and manuals for such product. Any expressed Warranty, or similar representation of performance set forth in the operation documentation for media or resin incorporated into the Manufacturer product shall be void and unenforceable unless the feedwater requirements set forth in the operating documentation for such product are unequivocally and strictly adhered to.

Limitations and Exclusions

THIS WARRANTY AND REMEDIES DESCRIBED HEREIN AND HEREIN ABOVE ARE EXCLUSIVE AND IN LIEU OF ANY AND ALL OTHER WARRANTY OR REMEDIES, EXPRESSED OR IMPLIED, INCLUDING WITHOUT LIMITATION, ANY IMPLIED WARRANTY OF MERCHANTABILITY OR FITNESS FOR A PARTICULAR PURPOSE. IN NO EVENT SHALL THE MANUFACTURER BE LIABLE FOR ANY CONSEQUENTIAL, INCIDENTAL OR OTHER SIMILAR TYPES OF DAMAGES, DAMAGES FOR THE LOSS OF PRODUCTION OR PROFITS, OR INJURY TO PERSON OR PROPERTY. NO PERSON HAS ANY AUTHORITY TO BIND THE MANUFACTURER TO OTHER THAN WHAT IS SET FORTH ABOVE.

THIS WARRANTY GIVES THE CUSTOMER SPECIFIC LEGAL RIGHTS AND THE CUSTOMER MAY ALSO HAVE OTHER RIGHTS WHICH VARY FROM JURISDICTION TO JURISDICTION. THE PARTIES RECOGNIZE AND AGREE, THAT IN ALL RESPECTS THE LAWS OF THE STATE OF CALIFORNIA SHALL APPLY TO AND SHALL GOVERN ANY INTERPRETATION OR LEGAL SIGNIFICANCE OF THIS DOCUMENT.

NO WARRANTY OR OTHER LIABILITY OF THE MANUFACTURER TO CUSTOMER UNDER THIS AGREEMENT OR OTHERWISE WILL IN ANY EVENT EXCEED THE COST OF REPLACEMENT OF THE APPLICABLE MANUFACTURER PRODUCT, PART, OR ACCESSORY THAT IS SUBJECT TO ANY BREACH OF THE MANUFACTURER'S WARRANTY. THE MANUFACTURER WILL NOT BE LIABLE FOR ANY DAMAGE TO ANY PROPERTY OF CUSTOMER OR TO CUSTOMER'S CUSTOMERS FOR ANY CONSEQUENTIAL, INCIDENTAL, OR ECONOMIC LOSS OR COMMERCIAL DAMAGE WHATSOEVER. REMEDIES HEREIN PROVIDED ARE EXPRESSLY MADE THE SOLE AND EXCLUSIVE REMEDIES FOR BREACH OF ANY WARRANTY OR OTHER OBLIGATION HEREUNDER EXPRESS OR IMPLIED OR FROM THE OPERATION OF LAW.

**For more information, visit
us at AXEONWater.com or
call 800-320-4074**



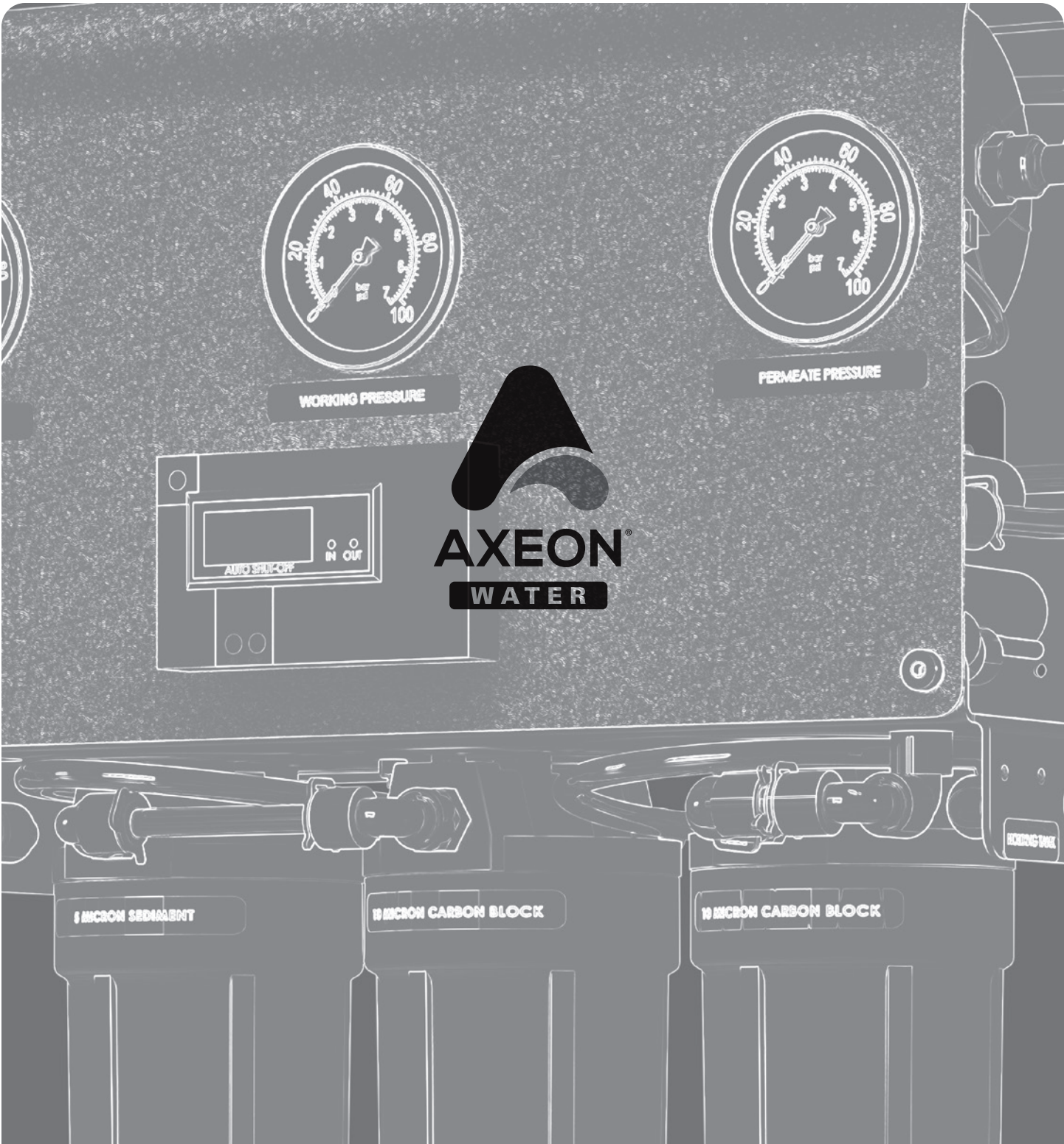

AXEON
WATER

Unbeatable performance backed by more than three decades of AXEON's experience in the water filtration industry. Look for our Watermark of Distinction. **Call (800) 320-4074 or visit us at AXEONwater.com to learn more.**