



MC Ultima

UNRIVALLED,
INDIVIDUAL &
DISTINCTIVE



Nestled quietly within the heart of Monaco is our small, but perfectly formed factory, hand-crafting espresso machines since 1956. We combine a genuine passion for innovation and coffee excellence, with exceptional quality and reliability to produce the finest machines for any circumstance or environment.

www.conti-espresso.com



MC Ultima



The MC Ultima is an evolution of our flagship model, with a sharpened more efficient design, enhanced ergonomics, more intuitive software and endless custom options, we have taken every element of this machine, and tuned it to perfection.



Smaller Footprint – Sharper Lines – Cleaner Materials

Modern day coffee bars are sleek, efficient and deliberately sparse in their design. With space at such a premium, it made perfect sense to take every dimension of the original Monte Carlo and shave precious millimetres, to make the machine lower and leaner in every way. We have managed to achieve an overall reduction in size of nearly 30% without any reduction in performance or capability. As a result of the cleaner look, we fully encapsulated the machine in sustainable, recyclable metals.



Full Colour User-Friendly Control Panel & Recipe Book

The Monte Carlo has always been the baristas most useful tool but now with the intuitive TFT touch display, making small adjustments has become even easier. With a full colour screen, and recognisable icons, setting up and tweaking the machines programmable features has become as easy as using a smart phone or tablet. Our latest addition to the software is a multi-page 'recipe book'. Allowing you to log your favourite coffees and brew ratios – and making them quickly accessible during service without the need for post-it notes!



Customisation

As with the Monte Carlo, the MC Ultima offers numerous custom options. We have extended our standard colour palette which now includes *Aluminium Grey* to accompany Ultima specific colours, which are *Graphite Black* and *Papyrus White*. By combining both high polish gloss with super matt textured panels, we have created further depth and accentuated the sharp design. We will also introduce a number of custom options, to include custom RAL powder coating, bespoke metal finishes plus a selection of sustainably sourced wooden accessories – no two Ultima's will be the same.

Additional Features:

'Infinite Actuate' steam Lever
Allowing the barista precise control over steam flow, making perfect texturing simple, even with an array of sensitive alternative milks.

Customisable Standby Mode
Upload pictures and logos to the machine displaying these custom images when the machine reverts to standby mode after a period of inactivity.

42% Larger Cup Warmer
Removing the need to precariously stack cups which not only reduces breakages, it also provides a clearer view over the machine enabling the barista to interact more freely with the coffee drinker.

Redefined internal layout
By relocating many of the machines key components we have saved more space whilst making the ongoing maintenance of the machine easier and more efficient, saving downtime and prolonging machine life cycle.

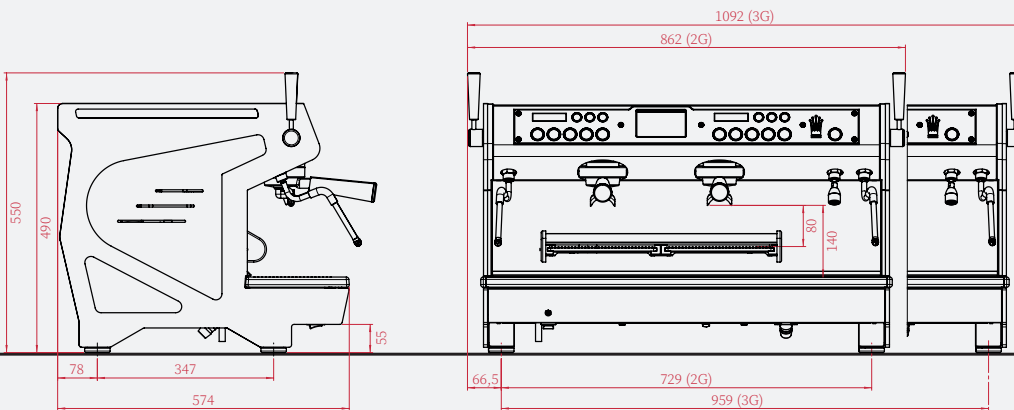

	2 Group	3 Group
Height (mm)	490	490
Width (mm)	862	1092
Depth (mm)	574	574
Weight (kg)	87	105
Steam Boiler Size (Litres)	10	14
Coffee Boiler Size (Litres)	0.9 x 2	0.9 x 3
Group Element (W)	100	100
Steam Boiler Element (W)	4200/6000	6000
Coffee Boiler Element (W)	1000/2500	1000/2500
Total Power (W)	1900-6700/3000-11500*	2600-9600/3000-14100*
Voltage (V)	400 (230 option)	400

Colour Options:



*Please note total power can be adjusted within power management.



Conti Monaco
Email: conti@conti-espresso.com
Tel: +377 93 10 43 43
www.conti-espresso.com

1 Avenue Albert II
B.P.119
MC 98007 - Monaco Cedex

