

# Dell PowerEdge R7715

## Technical Guide

## Notes, cautions, and warnings

 **NOTE:** A NOTE indicates important information that helps you make better use of your product.

 **CAUTION:** A CAUTION indicates either potential damage to hardware or loss of data and tells you how to avoid the problem.

 **WARNING:** A WARNING indicates a potential for property damage, personal injury, or death.

<b>Chapter 1: PowerEdge R7715 system configurations and features.....</b>	<b>5</b>
Key workloads.....	5
New technologies.....	6
<b>Chapter 2: Product comparison.....</b>	<b>7</b>
<b>Chapter 3: Chassis views and features.....</b>	<b>11</b>
System configurations - front view for PowerEdge R7715 system.....	11
Left Control Panel (LCP)- Secondary.....	19
Right Control Panel (RCP) - Primary (RCP).....	20
System configurations - rear view for PowerEdge R7715 system.....	21
Inside the system .....	23
<b>Chapter 4: Processor.....</b>	<b>27</b>
Processor features.....	27
Supported processors.....	27
<b>Chapter 5: Memory subsystem.....</b>	<b>29</b>
Supported memory.....	29
System memory guidelines.....	29
CXL memory.....	32
<b>Chapter 6: Storage.....</b>	<b>33</b>
Storage controllers.....	33
Supported Drives.....	34
Internal storage configuration.....	34
Boot Optimized Storage Solution (BOSS).....	35
BOSS feature matrix.....	35
<b>Chapter 7: Networking.....</b>	<b>36</b>
Overview.....	36
OCP 3.0 support.....	36
Supported OCP cards.....	36
OCP NIC 3.0 vs 2.0.....	37
<b>Chapter 8: PCIe subsystem.....</b>	<b>38</b>
PCIe risers.....	38
<b>Chapter 9: Power, thermal, and acoustics.....</b>	<b>44</b>
Power.....	44
Power Supply Units.....	44
Thermal.....	47
Thermal design.....	47

Acoustics.....	48
Acoustical configurations of R7715 .....	48
<b>Chapter 10: Rack, rails, and cable management.....</b>	<b>50</b>
Rails and cable management information.....	50
<b>Chapter 11: Operating Systems and Virtualization.....</b>	<b>59</b>
Supported operating systems.....	59
<b>Chapter 12: Dell Systems Management.....</b>	<b>60</b>
Integrated Dell Remote Access Controller (iDRAC).....	60
Systems Management software support matrix.....	61
<b>Chapter 13: Appendix A: Additional specifications.....</b>	<b>63</b>
Chassis dimensions .....	63
System weight.....	64
NIC port specifications.....	64
DPU Specifications.....	65
Video specifications.....	65
USB Ports.....	66
PSU rating.....	66
Environmental specifications.....	68
Thermal restriction matrix.....	70
<b>Chapter 14: Appendix B. Standards compliance.....</b>	<b>79</b>
<b>Chapter 15: Appendix C: Additional resources.....</b>	<b>80</b>
<b>Chapter 16: Appendix D: Services.....</b>	<b>81</b>
Why attach service contracts.....	81
ProSupport Infrastructure Suite .....	81
Specialty Support Services.....	83
ProDeploy Infrastructure Suite.....	84
Supplemental Deployment Services .....	87
Unique Deployment Scenarios.....	88
DAY 2 – Automation Services with Ansible.....	89
Dell Technologies Consulting Services.....	89
Dell Technologies Consulting Services.....	90

# PowerEdge R7715 system configurations and features

The PowerEdge R7715 system is a 2U server that supports:

- One 5<sup>th</sup> Generation AMD EPYC 9005 Series processor with up to 160 Zen5 cores per processor
- Twenty-four DIMM slots
- Two redundant AC or DC power supply units
- No backplane configuration
- Up to 2 x U.2 drives
- Up to 8 x 2.5-inch Universal drives
- Up to 8 x EDSFF E3.S Gen5 NVMe drives
- Up to 12 x 3.5-inch SAS/SATA drives
- Up to 16 x 2.5-inch SAS/SATA + 8 x U.2 drives
- Up to 16 x 2.5-inch SAS/SATA SSD drives
- Up to 16 x EDSFF E3.S Gen5 NVMe drives
- Up to 24 x 2.5-inch SAS/SATA drives
- Up to 32 x EDSFF E3.S Gen5 NVMe drives
- Up to 40 x EDSFF E3.S Gen5 NVMe drives

**NOTE:** The system board is known as the Host Processor Module (HPM) board in this document.

**NOTE:** For more information about how to hot swap NVMe PCIe SSD device, see the *Dell Express Flash NVMe PCIe SSD User's Guide* at [Dell Support](#) page > **Browse all products** > **Infrastructure** > **Data Center Infrastructure** > **Storage Adapters & Controllers** > **Dell PowerEdge Express Flash NVMe PCIe SSD** > **Select This Product** > **Documentation** > **Manuals and Documents**.

**NOTE:** All instances of SAS, SATA drives are referred to as drives in this document, unless specified otherwise.

**CAUTION:** Do not install GPUs, network cards, or other PCIe devices on your system that are not validated and tested by Dell. Damage caused by unauthorized and invalidated hardware installation will null and void the system warranty.

## Topics:

- [Key workloads](#)
- [New technologies](#)

## Key workloads

The Dell PowerEdge R7715 offers powerful performance in a purpose-built, cyber resilient, mainstream server. Ideal for:

- Data Analytics
- Dense virtualization
- Software defined storage

# New technologies



The PowerEdge R7715 can handle demanding workloads and applications, such as data warehouses, eCommerce, databases, and high-performance computing (HPC).

**Table 1. New technologies**

Technology	Detailed Description
AMD EPYC 5th Generation 9005 Series	Core count: Up to 160 cores for Zen5 processor
	CXL 2.0: supports Type 3 memory <b>i</b> <b>NOTE:</b> The AMD 9005 series CPUs support CXL 2.0 devices Type 1, Type 2, and Type 3, whereas the PowerEdge R7715 supports only CXL Type 3 memory devices.
	PCIe link encryption and PCIe hotplug port reconfiguration.
	Maximum TDP: 400 W
6400 MT/s DDR5 Memory	Up to 12 channels per CPU and 24 DIMMs in total
	Supports RDIMM with ECC up to 5200 MT/s. (1 of 2 DPC) and 4400 MT/s (2 of 2 DPC)
PCIe Gen	Gen5 slots
PCIe Slot	Up to eight PCIe slots with x16 lanes
Rear I/O	Rear OCP FLOP with DC-MHS compliant
	BOSS-N1 Datacenter Modular Hardware System (BOSS-N1 DC-MHS) module
FPGA PESTI	Support payload data of Front PERC 12 and BOSS N1-DC-MHS
DC-SCM	Datacenter-ready Secure Control Module
Software RAID	N/A
Power supplies	M-CRPS 73.5 mm and 60 mm support

## Product comparison

**Table 2. Comparison of PowerEdge R7715 and R7615**

Feature	PowerEdge R7715	PowerEdge R7615
<b>Processor</b>	One 5 <sup>th</sup> Generation AMD EPYC 9005 Series processor with up to 160 cores for Zen5 processor	One 4th Generation AMD® EPYC Genoa (SP5) processor with up to 128 cores for Zen4c processor
<b>Chipset</b>	AMD chipset	AMD chipset
<b>Accelerators</b>	Up to three 400 W Double wide or six 75 W single wide GPUs	Up to three 300 W or six 75 W GPUs
<b>Memory</b>		
DIMM speed	Up to 5200 MT/S	up to 4800 MT/S
Memory type	RDIMM	RDIMM
Memory module slots	24 DDR5 DIMM slots	12 DDR5 DIMM slots
	 <b>NOTE:</b> Supports registered ECC DDR5 DIMMs only.	 <b>NOTE:</b> Supports registered ECC DDR5 DIMMs only.
<b>Storage</b>		
Front bays	<ul style="list-style-type: none"> <li>No backplane configuration</li> <li>Up to 2 x U.2 SSDs</li> <li>Up to 8 x 2.5-inch Universal SSDs</li> <li>Up to 8 x EDSFF E3.S Gen5 NVMe drives</li> <li>Up to 12 x 3.5-inch SAS/SATA drives</li> <li>Up to 16 x 2.5-inch SAS/SATA SSD + 8 x U.2 drives</li> <li>Up to 16 x 2.5-inch SAS/SATA SSD drives</li> <li>Up to 16 x EDSFF E3.S Gen5 NVMe drives</li> <li>Up to 24 x 2.5-inch SAS/SATA drives</li> <li>Up to 32 x EDSFF E3.S Gen5 NVMe drives</li> <li>Up to 40 x EDSFF E3.S Gen5 NVMe drives</li> </ul>	<ul style="list-style-type: none"> <li>Up to 8 x 3.5-inch SAS4/SATA (HDD/SSD) max 160 TB</li> <li>Up to 12 x 3.5-inch SAS/SATA (HDD/SSD) max 240 TB</li> <li>Up to 8 x 2.5-inch SAS/SATA/NVMe (HDD/SSD) max 122.88 TB</li> <li>Up to 16 x 2.5-inch SAS/SATA/NVMe (HDD/SSD) max 245.76 TB</li> <li>Up to 24 x 2.5-inch SAS/SATA/NVMe (HDD/SSD) max 368.64 TB</li> <li>Up to 8 x E3.S (NVMe Gen5 ) max 61.44 TB</li> <li>Up to 16 x E3.S (NVMe Gen5 ) max 122.88 TB</li> <li>Up to 32 x E3.S (NVMe Gen5 ) max 245.76 TB</li> </ul>
Rear bays	N/A	<ul style="list-style-type: none"> <li>Up to 2 x 2.5-inch SAS4/SATA/NVMe (HDD/SSD) max 30.72 TB</li> <li>Up to 4 x 2.5-inch SAS4/SATA/NVMe (HDD/SSD) max 61.44 TB</li> <li>Up to 4 x E3.S (NVMe Gen5 ) max 30.72 TB</li> </ul>
<b>Storage controllers</b>		
Internal controllers	PERC H365i, H965i, H975i	HBA355i, H355, H755, H755N, H965i, HBA465i
External controllers	HBA465e, H965e	HBA355e, HBA465e, H965e
Software RAID	N/A	S160

**Table 2. Comparison of PowerEdge R7715 and R7615 (continued)**

Feature	PowerEdge R7715	PowerEdge R7615
Internal boot	Boot Optimized Storage Subsystem (BOSS-N1 DC-MHS) N/A	Boot Optimized Storage Subsystem (BOSS-N1) Internal USB
<b>Power supply</b>	<ul style="list-style-type: none"> <li>• 3200 W 277 VAC and HVDC, hot swap redundant</li> <li>• 3200 W Titanium 200-240 VAC or 240 HVDC, hot swap redundant</li> <li>• 2400 W Titanium 200-240 VAC or 240 HVDC, hot swap redundant</li> <li>• 1800 W Titanium 100-240 VAC or 240 VDC, hot swap redundant *</li> <li>• 1500 W Titanium 100-240 VAC or 240 VDC, hot swap redundant</li> <li>• 1500 W 277 VAC and HVDC, hot swap redundant</li> <li>• 1400 W (-48)-(-60) VDC</li> <li>• 1100 W Titanium 100-240 VAC or 240 VDC, hot swap redundant</li> <li>• 1100 W Platinum 100-240 VAC or 240 VDC, hot swap redundant</li> <li>• 800 W Titanium 100-240 VAC or 240 VDC, hot swap redundant</li> <li>• 800 W Platinum 100-240 VAC or 240 VDC, hot swap redundant</li> </ul>	Hot swap PSUs with full redundancy. <ul style="list-style-type: none"> <li>• 700 W Titanium 200-240 VAC or 240 HVDC</li> <li>• 800 W Platinum 100-240 VAC or 240 HVDC</li> <li>• 1100 W LVDC -48 - -60 VDC</li> <li>• 1100 W Titanium 100-240 VAC or 240 HVDC</li> <li>• 1400 W Titanium 100-240 VAC or 240 HVDC</li> <li>• 1400 W Titanium 277 VAC or 336 HVDC</li> <li>• 1800 W Titanium 200—240 VAC or 240 HVDC</li> <li>• 2400 W Platinum 100-240 VAC or 240 HVDC</li> </ul>
<b>Cooling Options</b>	<ul style="list-style-type: none"> <li>• Air cooling</li> <li>• Direct Liquid cooling (DLC)</li> </ul>	Air Cooling
<b>Fans</b>	Up to six High Performance Gold/VeryHigh Performance hot plug fans	Up to six High-performance Silver/High Performance Gold hot plug fans
<b>Ports</b>		
Network options	1 Gb dedicated BMC Ethernet port	2 x 1 GbE LOM card (optional)
	2 x OCP NIC 3.0 card (Optional)	1 x OCP card 3.0 (optional) <b>i</b> <b>NOTE:</b> The system allows either LOM card or OCP card or both to be installed in the system.
Front ports	1 x USB 2.0 Type-A(optional LCP KVM)	1 x iDRAC Direct (Micro-AB USB) port
	1 x USB 2.0 Type-C (HOST/BMC Direct)	1 x USB 2.0
	1 x Mini-Display port (optional LCP KVM)	1 x VGA
Rear ports	1 Gb dedicated BMC Ethernet port	1 x Dedicated iDRAC Ethernet port
	2 x USB 3.1	1 x USB 2.0
	1 x VGA	1 x USB 3.0
		1 x Serial (optional)
	1 x VGA (optional for Direct Liquid Cooling configuration)	
Internal ports	N/A	1 x USB 3.0 (optional)
<b>Slots</b>		
PCIe	Up to eight PCIe Gen5 slots	Up to four PCIe Gen5 slots

**Table 2. Comparison of PowerEdge R7715 and R7615 (continued)**

<b>Feature</b>	<b>PowerEdge R7715</b>	<b>PowerEdge R7615</b>
<b>Form factor</b>	2U rack server	2U rack server
Height	86.8 mm (3.41 inches)	86.8 mm (3.41 inches)
Width	482.0 mm (18.97 inches)	482.0 mm (18.97 inches)
Depth	802.4 mm (31.59 inches) with PSU handle	772.13mm (30.39 inches)
Weight	Max 28.68 kg (63.22 lbs)	Max 34.5 kg (76.05 lbs)
Bezel	Optional metal bezel	Optional LCD bezel or security bezel
<b>System management</b>		
Embedded management	<ul style="list-style-type: none"> <li>• iDRAC10 Enterprise</li> <li>• iDRAC10 Datacenter</li> <li>• iDRAC10</li> <li>• iDRAC Direct</li> <li>• iDRAC RESTful API with Redfish</li> <li>• Racadm CLI</li> <li>• Quick Sync 2 wireless module</li> </ul>	<ul style="list-style-type: none"> <li>• iDRAC9</li> <li>• iDRAC Direct</li> <li>• iDRAC RESTful API with Redfish</li> <li>• iDRAC Service Manual</li> <li>• Quick Sync 2 wireless module</li> </ul>
OpenManage console	<ul style="list-style-type: none"> <li>• OpenManage Enterprise (OME)</li> <li>• OME Power Manager</li> <li>• OME Services</li> <li>• OME Update Manager</li> <li>• OME APEX AIOps Observability</li> <li>• OME Integration for VMware vCenter (with VMware Aria Operations)</li> <li>• OME Integration for Microsoft System Center</li> <li>• OpenManage Integration for Windows Admin Center</li> </ul>	<ul style="list-style-type: none"> <li>• OpenManage Enterprise</li> <li>• OpenManage Power Manager plug-in</li> <li>• OpenManage Services plug-in</li> <li>• OpenManage Update Manager plug-in</li> </ul>
Mobility	OpenManage Mobile	OpenManage Mobile
Tools	IPMI	IPMI
Change Management	<ul style="list-style-type: none"> <li>• Dell Repository Manager</li> <li>• Dell System Update</li> <li>• Enterprise Catalogs</li> <li>• Server Update Utility (SUU)</li> </ul>	N/A
OpenManage Integrations	<ul style="list-style-type: none"> <li>• Red Hat Ansible Collections</li> <li>• Terraform Providers</li> </ul>	<ul style="list-style-type: none"> <li>• BMC True sight</li> <li>• Microsoft System Center</li> <li>• OpenManage Integration with ServiceNow</li> <li>• Red Hat Ansible Modules</li> <li>• Terraform Providers</li> <li>• VMware vCenter and vRealize Operations Manager</li> </ul>
Security	<ul style="list-style-type: none"> <li>• AMD Secure Encrypted Virtualization (SEV)</li> <li>• AMD Secure Memory Encryption (SME)</li> <li>• Cryptographically signed firmware</li> <li>• Data at Rest Encryption (SEDs with local or external key mgmt)</li> <li>• Secure Boot</li> </ul>	<ul style="list-style-type: none"> <li>• AMD Secure Encrypted Virtualization (SEV)</li> <li>• AMD Secure Memory Encryption (SME)</li> <li>• Cryptographically signed firmware</li> <li>• Data at Rest Encryption (SEDs with local or external key mgmt.</li> <li>• Secure Boot</li> </ul>

**Table 2. Comparison of PowerEdge R7715 and R7615 (continued)**

Feature	PowerEdge R7715	PowerEdge R7615
	<ul style="list-style-type: none"> <li>● Secured Component Verification (Hardware integrity check)</li> <li>● Secure Erase</li> <li>● Silicon Root of Trust</li> <li>● System Lockdown</li> <li>● TPM 2.0 FIPS, CC-TCG certified</li> <li>● Chassis Intrusion Detection</li> </ul>	<ul style="list-style-type: none"> <li>● Secured Component Verification (Hardware integrity check)</li> <li>● Secure Erase</li> <li>● Silicon Root of Trust</li> <li>● System Lockdown (requires iDRAC9 Enterprise or Datacenter)</li> <li>● TPM 2.0 FIPS, CC-TCG certified, TPM 2.0 China NationZ</li> <li>● Chassis Intrusion Detection</li> </ul>
<b>Operating System and Hypervisors</b>	<ul style="list-style-type: none"> <li>● Canonical Ubuntu Server LTS</li> <li>● Windows Server with Hyper-V</li> <li>● Red Hat Enterprise Linux</li> <li>● VMware ESXi</li> <li>● SUSE Linux Enterprise Server</li> </ul> <p>For specifications and interoperability details, see <a href="#">Dell Enterprise Operating Systems on Servers, Storage, and Networking</a> page at <a href="#">OSsupport</a></p>	<ul style="list-style-type: none"> <li>● Canonical Ubuntu Server LTS</li> <li>● Windows Server with Hyper-V</li> <li>● Red Hat Enterprise Linux</li> <li>● SUSE Linux Enterprise Server</li> <li>● VMware ESXi</li> </ul> <p>For specifications and interoperability details, see <a href="#">Dell Enterprise Operating Systems on Servers, Storage, and Networking</a> page at <a href="#">OSsupport</a></p>

**NOTE:** This document provides a comprehensive list of product features. However, features marked with an asterisk (\*) may not be available at launch but introduced in future updates. Please note that this document does not confirm the availability or release timeline of any feature. For the most accurate and up-to-date information on feature availability, please refer to the product configurator page on dell.com.

**NOTE:** \* Feature not available at product launch in November, 2025. Please refer to the product configurator page on Dell.com to confirm feature availability.

## Chassis views and features

### Topics:

- System configurations - front view for PowerEdge R7715 system
- System configurations - rear view for PowerEdge R7715 system
- Inside the system

## System configurations - front view for PowerEdge R7715 system

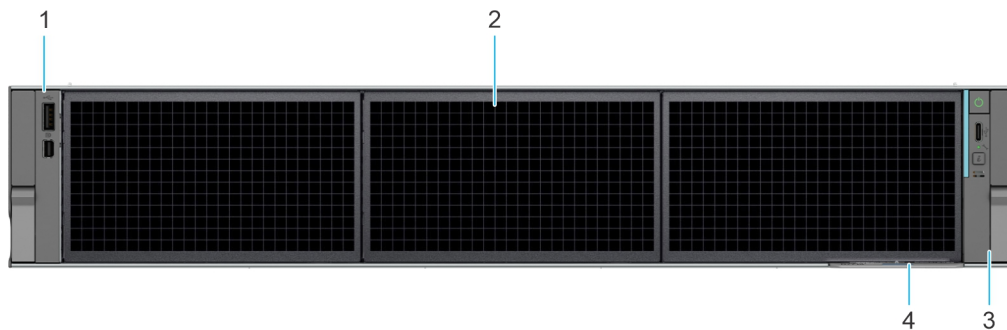

Figure 1. Front view of no backplane drive system

Table 3. Features are available on the front of the system

Item	Ports, panels, and slots	Icon	Description
1	Left Control Panel (LCP)- Secondary	N/A	<p>Contains the USB 2.0 Type-A port (optional LCP KVM) and the Mini DisplayPort (optional LCP KVM).</p> <ul style="list-style-type: none"> <li>• USB 2.0 Type-A port (optional LCP KVM): This port is USB 2.0-compliant with optional LCP KVM functions.</li> <li>• Mini DisplayPort: Enables you to connect a display device to the system.</li> </ul> <p><b>NOTE:</b> Use a certified Mini DisplayPort to DisplayPort cable complying with VESA DisplayPort standards for video output with a monitor.</p> <p><b>NOTE:</b> Mini DisplayPort to VGA or Mini DisplayPort to HDMI adapters are not recommended.</p>
2	Blank panel	N/A	Blank panel to allow air flow for thermal efficiency.
3	Right Control Panel (RCP) - Primary	N/A	Contains the power button, USB port, iDRAC Direct micro port, and the iDRAC Direct status LED.
4	Express service tag	N/A	The express service tag is a slide-out label panel that contains system information such as Service Tag, NIC, MAC address, and so on. If you have opted for the secure default access to iDRAC, the Information tag also contains the iDRAC secure default password.

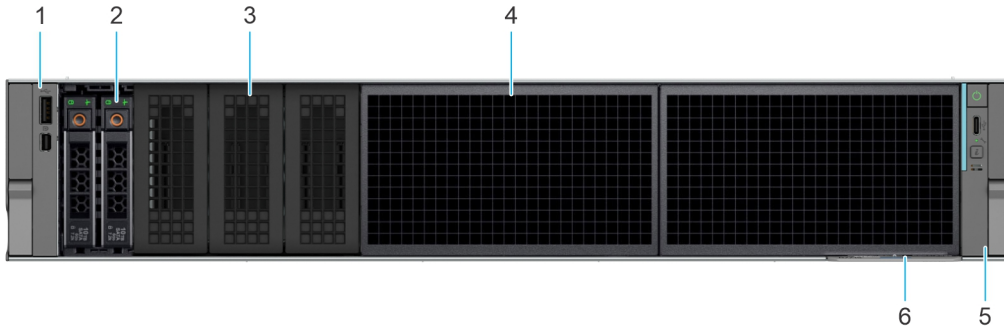

Figure 2. Front view of 2 x U.2 system

Table 4. Features are available on the front of the system

Item	Ports, panels, and slots	Icon	Description
1	Left Control Panel (LCP)- Secondary	N/A	<p>Contains the USB 2.0 Type-A port (optional LCP KVM) and the Mini DisplayPort (optional LCP KVM).</p> <ul style="list-style-type: none"> <li>• USB 2.0 Type-A port (optional LCP KVM): This port is USB 2.0-compliant with optional LCP KVM functions.</li> <li>• Mini DisplayPort: Enables you to connect a display device to the system.</li> </ul> <p><b>NOTE:</b> Use a certified Mini DisplayPort to DisplayPort cable complying with VESA DisplayPort standards for video output with a monitor.</p> <p><b>NOTE:</b> Mini DisplayPort to VGA or Mini DisplayPort to HDMI adapters are not recommended.</p>
2	Drive	N/A	Enables you to install drives that are supported on your system.
3 and 4	Blank panel	N/A	Blank panel to allow air flow for thermal efficiency.
5	Right Control Panel (RCP) - Primary	N/A	Contains the power button, USB port, iDRAC Direct micro port, and the iDRAC Direct status LED.
6	Express service tag	N/A	The express service tag is a slide-out label panel that contains system information such as Service Tag, NIC, MAC address, and so on. If you have opted for the secure default access to iDRAC, the Information tag also contains the iDRAC secure default password.

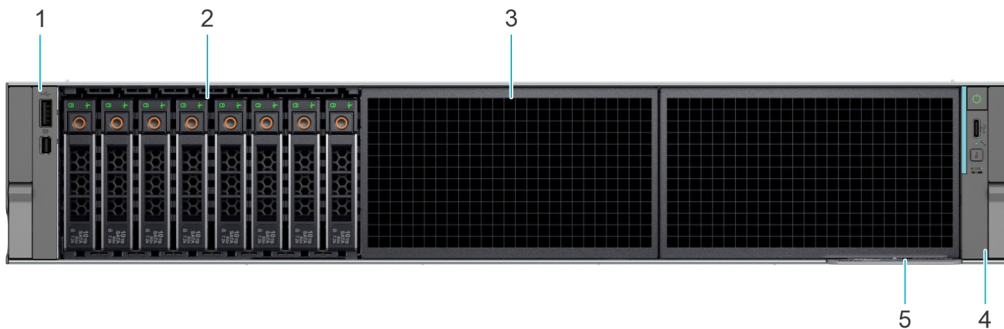
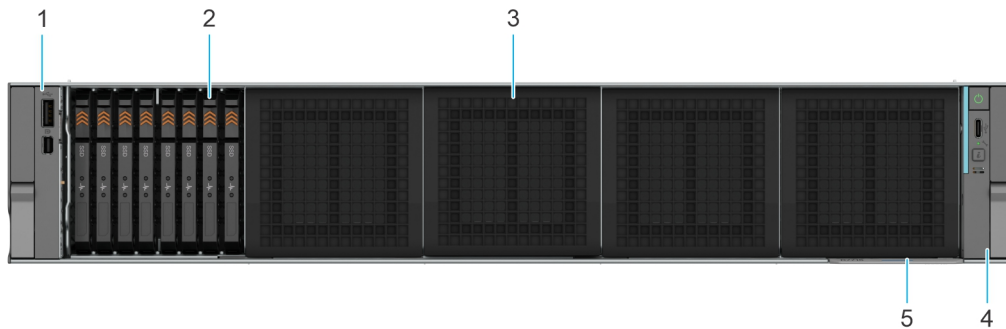

Figure 3. Front view of 8 x 2.5-inch Universal drives system

**Table 5. Features are available on the front of the system**

Item	Ports, panels, and slots	Icon	Description
1	Left Control Panel (LCP)- Secondary	N/A	<p>Contains the USB 2.0 Type-A port (optional LCP KVM) and the Mini DisplayPort (optional LCP KVM).</p> <ul style="list-style-type: none"> <li>• USB 2.0 Type-A port (optional LCP KVM): This port is USB 2.0-compliant with optional LCP KVM functions.</li> <li>• Mini DisplayPort: Enables you to connect a display device to the system.</li> </ul> <p><b>NOTE:</b> Use a certified Mini DisplayPort to DisplayPort cable complying with VESA DisplayPort standards for video output with a monitor.</p> <p><b>NOTE:</b> Mini DisplayPort to VGA or Mini DisplayPort to HDMI adapters are not recommended.</p>
2	Drive	N/A	Enables you to install drives that are supported on your system.
3	Blank panel	N/A	Blank panel to allow air flow for thermal efficiency.
4	Right Control Panel (RCP) - Primary	N/A	Contains the power button, USB port, iDRAC Direct micro port, and the iDRAC Direct status LED.
5	Express service tag	N/A	The express service tag is a slide-out label panel that contains system information such as Service Tag, NIC, MAC address, and so on. If you have opted for the secure default access to iDRAC, the Information tag also contains the iDRAC secure default password.



**Figure 4. Front view of 8 x EDSFF E3.S Gen5 NVMe drives system**

**Table 6. Features are available on the front of the system**

Item	Ports, panels, and slots	Icon	Description
1	Left Control Panel (LCP)- Secondary	N/A	<p>Contains the USB 2.0 Type-A port (optional LCP KVM) and the Mini DisplayPort (optional LCP KVM).</p> <ul style="list-style-type: none"> <li>• USB 2.0 Type-A port (optional LCP KVM): This port is USB 2.0-compliant with optional LCP KVM functions.</li> <li>• Mini DisplayPort: Enables you to connect a display device to the system.</li> </ul> <p><b>NOTE:</b> Use a certified Mini DisplayPort to DisplayPort cable complying with VESA DisplayPort standards for video output with a monitor.</p> <p><b>NOTE:</b> Mini DisplayPort to VGA or Mini DisplayPort to HDMI adapters are not recommended.</p>

**Table 6. Features are available on the front of the system (continued)**

Item	Ports, panels, and slots	Icon	Description
2	Drive	N/A	Enables you to install drives that are supported on your system.
3	Blank panel	N/A	Blank panel to allow air flow for thermal efficiency.
4	Right Control Panel (RCP) - Primary	N/A	Contains the power button, USB port, iDRAC Direct micro port, and the iDRAC Direct status LED.
5	Express service tag	N/A	The express service tag is a slide-out label panel that contains system information such as Service Tag, NIC, MAC address, and so on. If you have opted for the secure default access to iDRAC, the Information tag also contains the iDRAC secure default password.

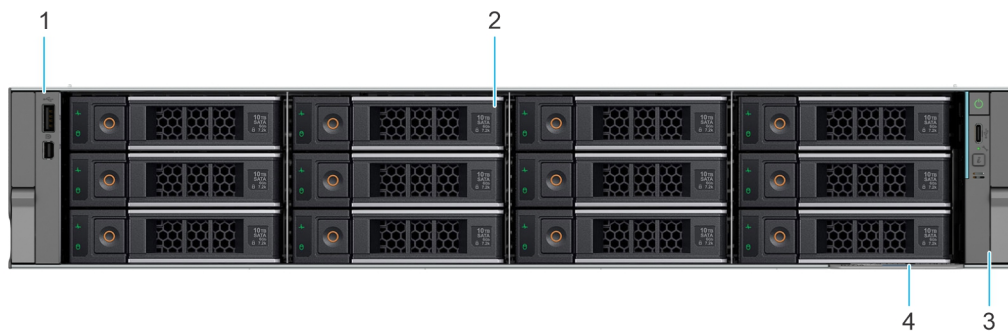

**Figure 5. Front view of 12 x 3.5-inch SAS/SATA drives system**

**Table 7. Features are available on the front of the system**

Item	Ports, panels, and slots	Icon	Description
1	Left Control Panel (LCP) - Secondary	N/A	<p>Contains the USB 2.0 Type-A port (optional LCP KVM) and the Mini DisplayPort (optional LCP KVM).</p> <ul style="list-style-type: none"> <li>• USB 2.0 Type-A port (optional LCP KVM): This port is USB 2.0-compliant with optional LCP KVM functions.</li> <li>• Mini DisplayPort: Enables you to connect a display device to the system.</li> </ul> <p><b>NOTE:</b> Use a certified Mini DisplayPort to DisplayPort cable complying with VESA DisplayPort standards for video output with a monitor.</p> <p><b>NOTE:</b> Mini DisplayPort to VGA or Mini DisplayPort to HDMI adapters are not recommended.</p>
2	Drive	N/A	Enables you to install drives that are supported on your system.
3	Right Control Panel (RCP) - Primary	N/A	Contains the power button, USB port, iDRAC Direct micro port, and the iDRAC Direct status LED.
4	Express service tag	N/A	The express service tag is a slide-out label panel that contains system information such as Service Tag, NIC, MAC address, and so on. If you have opted for the secure default access to iDRAC, the Information tag also contains the iDRAC secure default password.

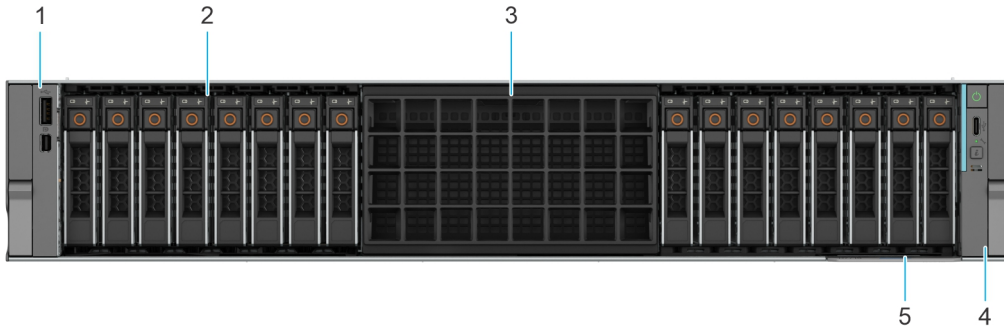

Figure 6. Front view of 16x 2.5-inch drives system

Table 8. Features are available on the front of the system

Item	Ports, panels, and slots	Icon	Description
1	Left Control Panel (LCP)- Secondary	N/A	<p>Contains the USB 2.0 Type-A port (optional LCP KVM) and the Mini DisplayPort (optional LCP KVM).</p> <ul style="list-style-type: none"> <li>• USB 2.0 Type-A port (optional LCP KVM): This port is USB 2.0-compliant with optional LCP KVM functions.</li> <li>• Mini DisplayPort: Enables you to connect a display device to the system.</li> </ul> <p><b>NOTE:</b> Use a certified Mini DisplayPort to DisplayPort cable complying with VESA DisplayPort standards for video output with a monitor.</p> <p><b>NOTE:</b> Mini DisplayPort to VGA or Mini DisplayPort to HDMI adapters are not recommended.</p>
2	Drive	N/A	Enables you to install drives that are supported on your system.
3	Blank panel	N/A	Blank panel to allow air flow for thermal efficiency.
4	Right Control Panel (RCP) - Primary	N/A	Contains the power button, USB port, iDRAC Direct micro port, and the iDRAC Direct status LED.
5	Express service tag	N/A	The express service tag is a slide-out label panel that contains system information such as Service Tag, NIC, MAC address, and so on. If you have opted for the secure default access to iDRAC, the Information tag also contains the iDRAC secure default password.

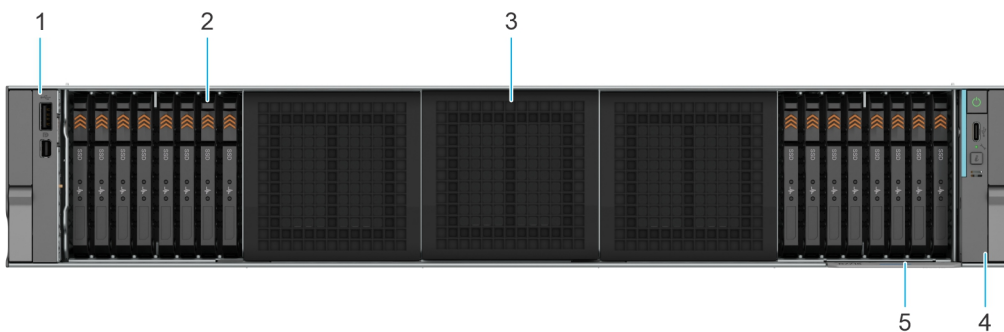

Figure 7. Front view of 16 x EDSFF Gen5 E3.s NVMe system

**Table 9. Features available on the front of the system**

Item	Ports, panels, and slots	Icon	Description
1	Left Control Panel (LCP)- Secondary	N/A	<p>Contains the USB 2.0 Type-A port (optional LCP KVM) and the Mini DisplayPort (optional LCP KVM).</p> <ul style="list-style-type: none"> <li>• USB 2.0 Type-A port (optional LCP KVM): This port is USB 2.0-compliant with optional LCP KVM functions.</li> <li>• Mini DisplayPort: Enables you to connect a display device to the system.</li> </ul> <p><b>NOTE:</b> Use a certified Mini DisplayPort to DisplayPort cable complying with VESA DisplayPort standards for video output with a monitor.</p> <p><b>NOTE:</b> Mini DisplayPort to VGA or Mini DisplayPort to HDMI adapters are not recommended.</p>
2	Drive	N/A	Enables you to install drives that are supported on your system.
3	Blank panel	N/A	Blank panel to allow air flow for thermal efficiency.
4	Right Control Panel (RCP) - Primary	N/A	Contains the power button, USB port, iDRAC Direct micro port, and the iDRAC Direct status LED.
5	Express service tag	N/A	The express service tag is a slide-out label panel that contains system information such as Service Tag, NIC, MAC address, and so on. If you have opted for the secure default access to iDRAC, the Information tag also contains the iDRAC secure default password.



**Figure 8. Front view of 16 x 2.5-inch SAS4/SATA + 8 x 2.5-inch U.2 NVMe system**

**Table 10. Features available on the front of system**

Item	Ports, panels, and slots	Icon	Description
1	Left Control Panel (LCP)- Secondary	N/A	<p>Contains the USB 2.0 Type-A port (optional LCP KVM) and the Mini DisplayPort.</p> <ul style="list-style-type: none"> <li>• USB 2.0 Type-A port (optional LCP KVM): This port is USB 2.0-compliant with optional LCP KVM functions.</li> <li>• Mini DisplayPort: Enables you to connect a display device to the system.</li> </ul> <p><b>NOTE:</b> Use a certified Mini DisplayPort to DisplayPort cable complying with VESA DisplayPort standards for video output with a monitor.</p> <ul style="list-style-type: none"> <li>• <b>NOTE:</b> Mini DisplayPort to VGA or Mini DisplayPort to HDMI adapters are not recommended.</li> </ul>

**Table 10. Features available on the front of system (continued)**

Item	Ports, panels, and slots	Icon	Description
2	Drive	N/A	Enables you to install drives that are supported on your system.
3	Right Control Panel (RCP) - Primary	N/A	Contains the power button, USB port, iDRAC Direct micro port, and the iDRAC Direct status LED
4	Express service tag	N/A	The express service tag is a slide-out label panel that contains system information such as Service Tag, NIC, MAC address, and so on. If you have opted for the secure default access to iDRAC, the Information tag also contains the iDRAC secure default password.



**Figure 9. Front view of 24 x 2.5-inch SAS/SATA drives system**

**Table 11. Features available on the front of the system**

Item	Ports, panels, and slots	Icon	Description
1	Left Control Panel (LCP)- Secondary	N/A	<p>Contains the USB 2.0 Type-A port (optional LCP KVM) and the Mini DisplayPort (optional LCP KVM).</p> <ul style="list-style-type: none"> <li>• USB 2.0 Type-A port (optional LCP KVM): This port is USB 2.0-compliant with optional LCP KVM functions.</li> <li>• Mini DisplayPort: Enables you to connect a display device to the system.</li> </ul> <p><b>NOTE:</b> Use a certified Mini DisplayPort to DisplayPort cable complying with VESA DisplayPort standards for video output with a monitor.</p> <p><b>NOTE:</b> Mini DisplayPort to VGA or Mini DisplayPort to HDMI adapters are not recommended.</p>
2	Drive	N/A	Enables you to install drives that are supported on your system.
3	Right Control Panel (RCP) - Primary	N/A	Contains the power button, USB port, iDRAC Direct micro port, and the iDRAC Direct status LED.
4	Express service tag	N/A	The express service tag is a slide-out label panel that contains system information such as Service Tag, NIC, MAC address, and so on. If you have opted for the secure default access to iDRAC, the Information tag also contains the iDRAC secure default password.

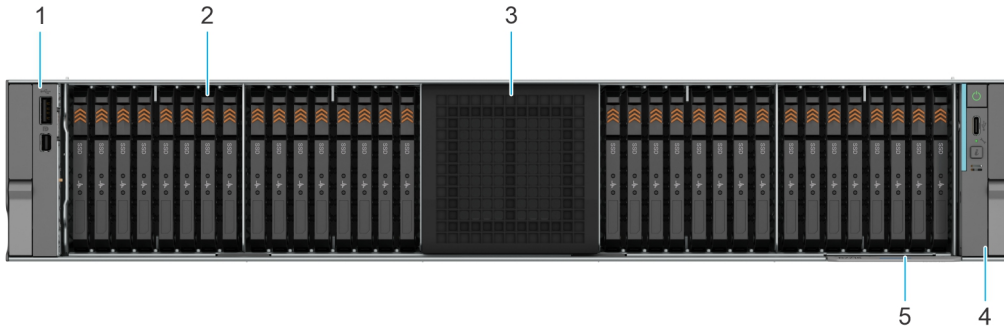

Figure 10. Front view of 32 x EDSFF Gen5 E3.s NVMe SSD system

Table 12. Features available on the front of the system

Item	Ports, panels, and slots	Icon	Description
1	Left Control Panel (LCP)- Secondary	N/A	<p>Contains the USB 2.0 Type-A port (optional LCP KVM) and the Mini DisplayPort (optional LCP KVM).</p> <ul style="list-style-type: none"> <li>• USB 2.0 Type-A port (optional LCP KVM): This port is USB 2.0-compliant with optional LCP KVM functions.</li> <li>• Mini DisplayPort: Enables you to connect a display device to the system.</li> </ul> <p><b>NOTE:</b> Use a certified Mini DisplayPort to DisplayPort cable complying with VESA DisplayPort standards for video output with a monitor.</p> <p><b>NOTE:</b> Mini DisplayPort to VGA or Mini DisplayPort to HDMI adapters are not recommended.</p>
2	Drive	N/A	Enables you to install drives that are supported on your system.
3	Blank panel	N/A	Blank panel to allow air flow for thermal efficiency.
4	Right Control Panel (RCP) - Primary	N/A	Contains the power button, USB port, iDRAC Direct micro port, and the iDRAC Direct status LED.
5	Express service tag	N/A	The express service tag is a slide-out label panel that contains system information such as Service Tag, NIC, MAC address, and so on. If you have opted for the secure default access to iDRAC, the Information tag also contains the iDRAC secure default password.



Figure 11. Front view of 40 x EDSFF E3.S Gen5 NVMe drives system

**Table 13. Features available on the front of the system**

Item	Ports, panels, and slots	Icon	Description
1	Left Control Panel (LCP)- Secondary	N/A	<p>Contains the USB 2.0 Type-A port (optional LCP KVM) and the Mini DisplayPort (optional LCP KVM).</p> <ul style="list-style-type: none"> <li>• USB 2.0 Type-A port (optional LCP KVM): This port is USB 2.0-compliant with optional LCP KVM functions.</li> <li>• Mini DisplayPort: Enables you to connect a display device to the system.</li> </ul> <p><b>NOTE:</b> Use a certified Mini DisplayPort to DisplayPort cable complying with VESA DisplayPort standards for video output with a monitor.</p> <p><b>NOTE:</b> Mini DisplayPort to VGA or Mini DisplayPort to HDMI adapters are not recommended.</p>
2	Drive	N/A	Enables you to install drives that are supported on your system.
3	Right Control Panel (RCP) - Primary	N/A	Contains the power button, USB port, iDRAC Direct micro port, and the iDRAC Direct status LED.
4	Express service tag	N/A	The express service tag is a slide-out label panel that contains system information such as Service Tag, NIC, MAC address, and so on. If you have opted for the secure default access to iDRAC, the Information tag also contains the iDRAC secure default password.

## Left Control Panel (LCP)- Secondary

The LCP provides support for at-the-box-management or system health at a glance. The system health and system ID indicator are on the LCP of the system.

The LCP is offered in three SKUs:

- Blank
- KVM module
- Quick Sync 2.0

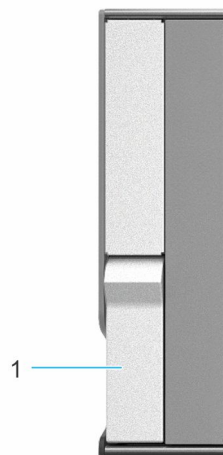

**Figure 12. LCP blank**

1. Blank control panel

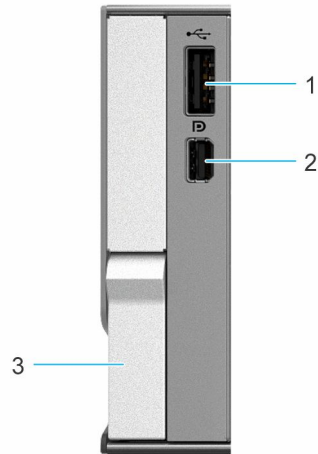

**Figure 13. LCP with optional KVM**

1. USB 2.0 (LCP/KVM)
2. Mini DisplayPort
3. Slam latch (NEBS Screw Underneath)

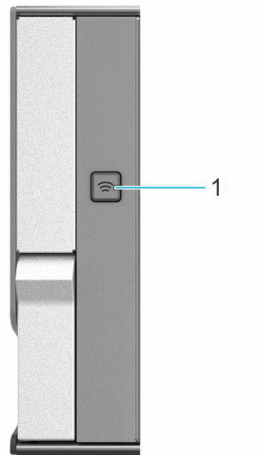

**Figure 14. Left Control Panel (LCP) - Secondary with optional Quick Sync 2.0**

1. Quick Sync 2.0 button

## Right Control Panel (RCP) - Primary (RCP)

The Right Control Panel (RCP) - Primary encompasses many of the features no longer supported by the left control panel.

Features of the Right Control Panel (RCP) - Primary include:

1. Slam latch (NEBS screw underneath)
2. System ID Button
3. USB 2.0 Type-C port
4. Status led for host
5. Power Button

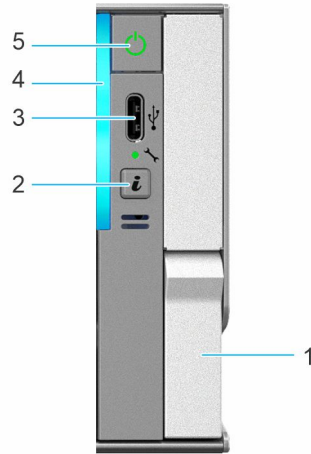

Figure 15. Right Control Panel (RCP) - Primary of R7715

Table 14. System health and system ID indicator codes

System health and system ID indicator code	Condition
Solid blue	Indicates that the system is powered on, is healthy, and system ID mode is not active. Press the system ID button to switch to system ID mode.
Blinking blue	Indicates that the system ID mode is active. Press the system ID button to switch to system health mode.
Blinking amber	Indicates that the system is experiencing a fault. Check the System Event Log for specific error messages. <a href="#">EEMI guide</a>

## System configurations - rear view for PowerEdge R7715 system

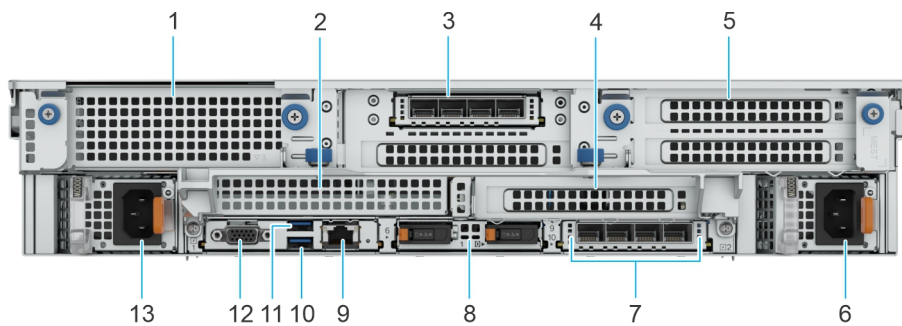







Figure 16. Rear view of the system

Table 15. Rear view of the system

Item	Ports, panels, or slots	Icon	Description
1	PCIe expansion card riser 1	N/A	Enables you to connect PCI Express expansion cards.
2	PCIe expansion card riser 2	N/A	Enables you to connect PCI Express expansion cards.
3	OCP NIC ports	N/A	This port supports OCP 3.0.
4	PCIe expansion card riser 4	N/A	Enables you to connect PCI Express expansion cards.
5	PCIe expansion card riser 5	N/A	Enables you to connect PCI Express expansion cards.



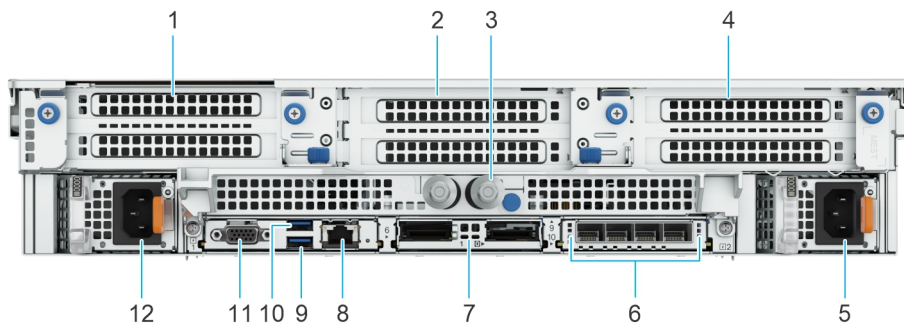

**Table 15. Rear view of the system (continued)**

Item	Ports, panels, or slots	Icon	Description
6	Power supply unit (PSU 2)		Indicates the PSU 2.
7	OCP NIC port	N/A	This port supports OCP 3.0.
8	BOSS-N1 DC-MHS	N/A	Enables you to install the BOSS-N1 DC-MHS.
9	Dedicated BMC Ethernet port	N/A	Enables you to remotely access Open Server Manager.
10	USB 3.1 port		The USB port is 9-pin and 3.0-compliant. This port enables you to connect USB devices to the system.
11	USB 3.1 port		The USB port is 9-pin and 3.0-compliant. This port enables you to connect USB devices to the system.
12	VGA port		Enables you to connect a display device to the system.
13	Power supply unit (PSU 1)		Indicates the PSU 1.

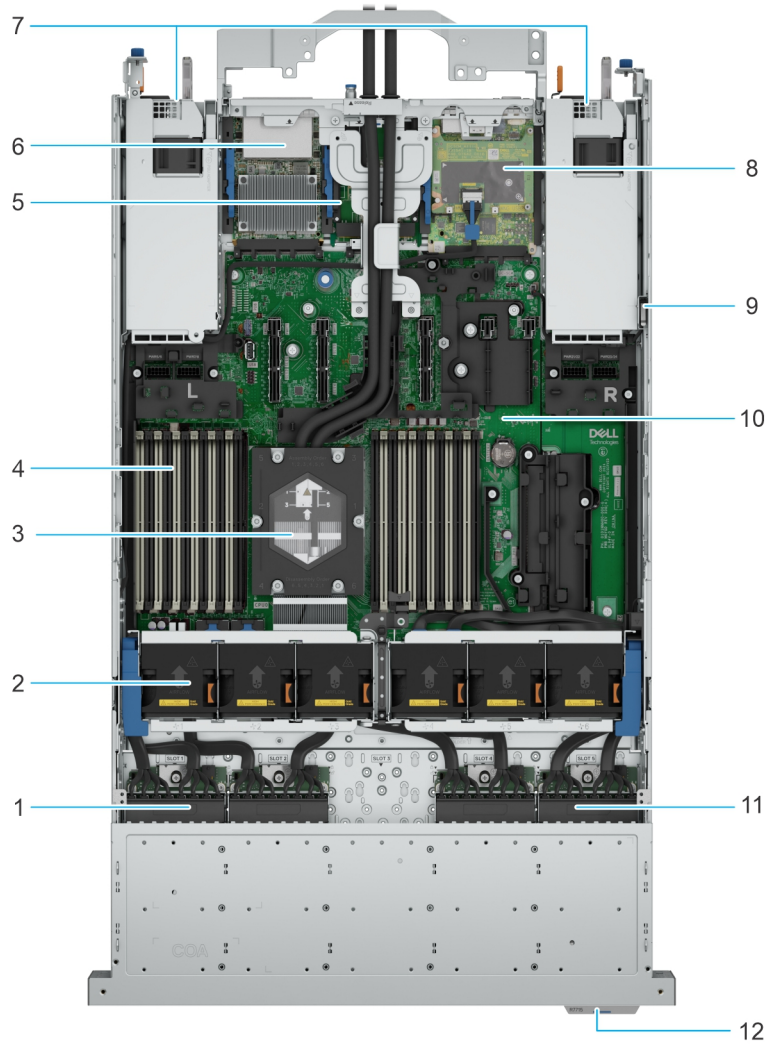

**Figure 17. Rear view of the liquid cooling system**

**Table 16. Rear view of the system**

Item	Ports, panels, or slots	Icon	Description
1	PCIe expansion card riser 1	N/A	Enables you to connect PCI Express expansion cards.
2	PCIe expansion card riser 3	N/A	Enables you to connect PCI Express expansion cards.
3	Liquid cooling module tubes	N/A	Cold coolant flows into the system from one tube and hot coolant leaves the system from another tube.
4	PCIe expansion card riser 5	N/A	Enables you to connect PCI Express expansion cards.
5	Power supply unit (PSU 2)		Indicates the PSU 2.
6	OCP NIC port	N/A	This port supports OCP 3.0.
7	BOSS-N1 DC-MHS	N/A	Enables you to install the BOSS-N1 DC-MHS.
8	Dedicated BMC Ethernet port	N/A	Enables you to remotely access Open Server Manager.
9	USB 3.1 port		The USB port is 9-pin and 3.0-compliant. This port enables you to connect USB devices to the system.
10	USB 3.1 port		The USB port is 9-pin and 3.0-compliant. This port enables you to connect USB devices to the system.
11	VGA port		Enables you to connect a display device to the system.
12	Power supply unit (PSU 1)		Indicates the PSU 1.

# Inside the system



**Figure 18. Inside the liquid cooling configuration system**

- |                          |                         |
|--------------------------|-------------------------|
| 1. Backplane             | 2. Cooling fans         |
| 3. Liquid cooling module | 4. Memory module slots  |
| 5. BOSS-N1 DC-MHS        | 6. OCP 3.0 NIC card     |
| 7. Power supplies        | 8. DC-SCM card          |
| 9. Intrusion switch      | 10. HPM board           |
| 11. Backplane            | 12. Express service tag |

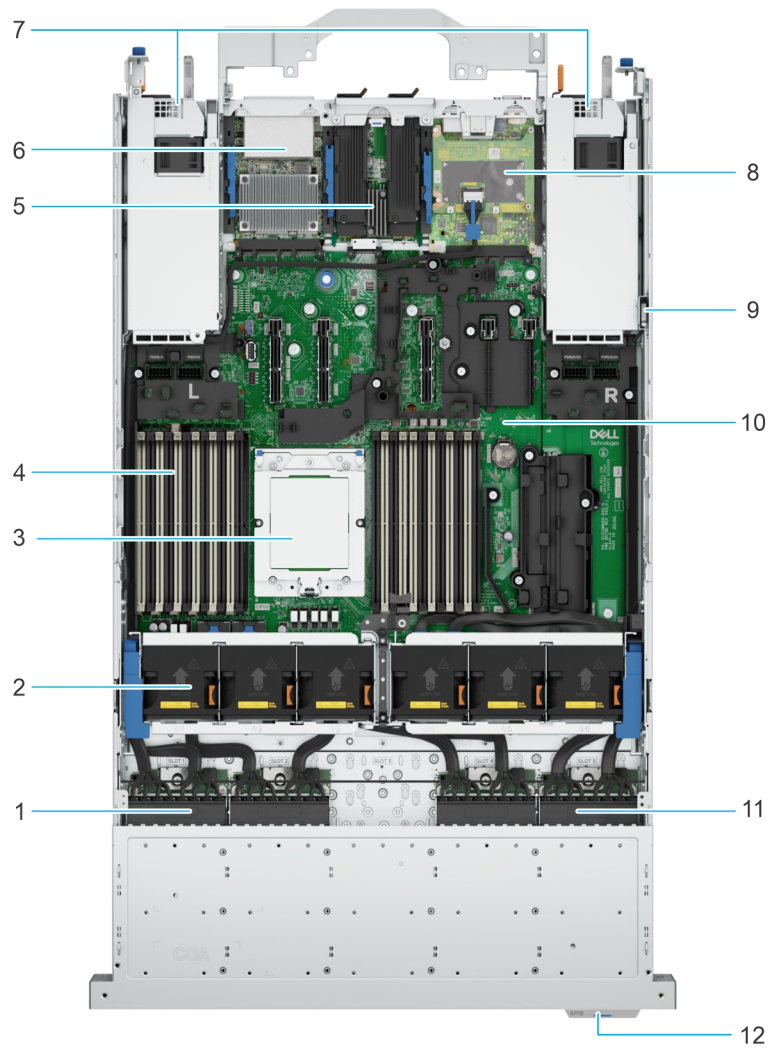

**Figure 19. Inside the system**

1. Backplane
2. Cooling fans
3. CPU
4. Memory module slots
5. BOSS-N1 DC-MHS
6. OCP 3.0 NIC card
7. Power supplies
8. DC-SCM card
9. Intrusion switch
10. HPM board
11. Backplane
12. Express service tag

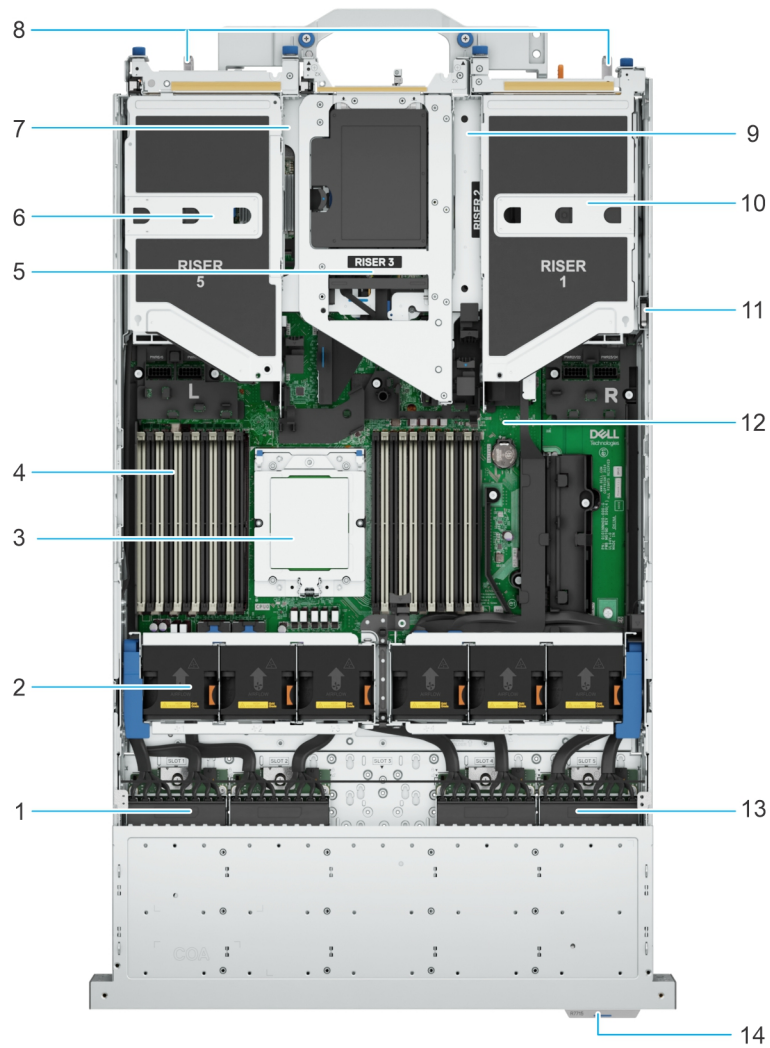

**Figure 20. Inside the system with all risers**

1. Backplane
2. Cooling fans
3. CPU
4. Memory module slots
5. Riser 3
6. Riser 5
7. Riser 4
8. Power supplies
9. Riser 2
10. Riser 1
11. Intrusion switch
12. HPM board
13. Backplane
14. Express service tag

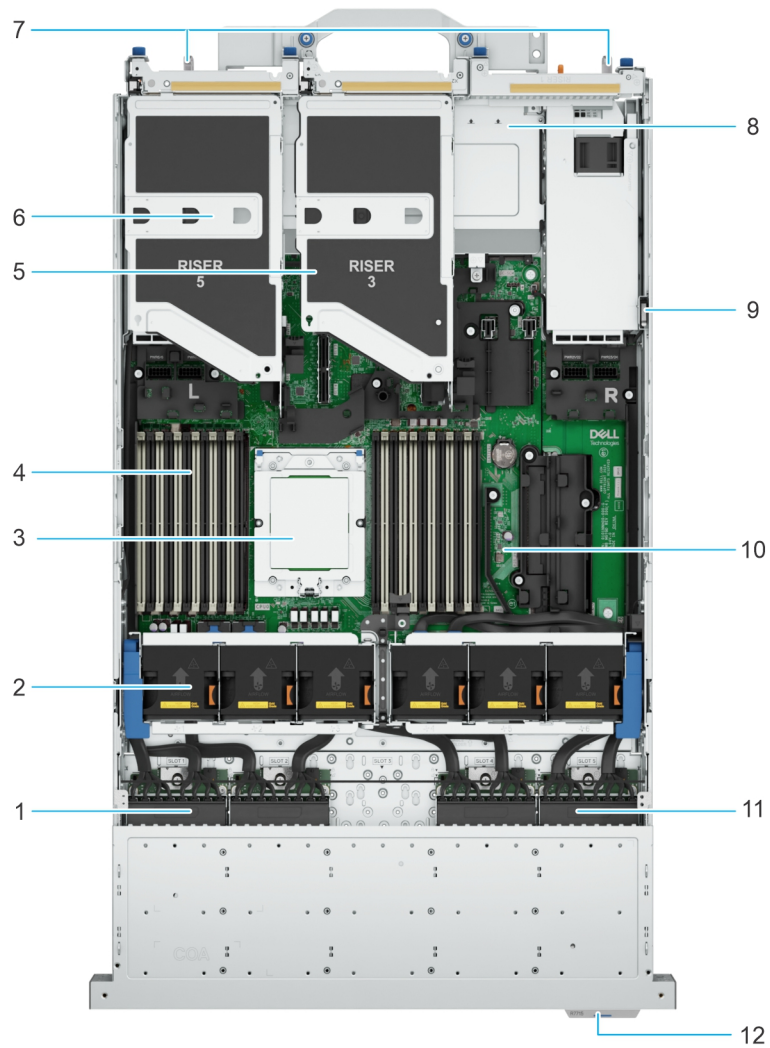

**Figure 21. Inside the system with all the riser 3 and 5**

1. Backplane
2. Cooling fans
3. CPU
4. Memory module slots
5. Riser 3
6. Riser 5
7. Power supplies
8. Riser2 and Riser4 FH blank
9. Intrusion switch
10. HPM board
11. Backplane
12. Express service tag

# Processor

## Topics:

- [Processor features](#)

## Processor features

The AMD EPYC™ 9005 system on a chip (SOC) is the next-generation data center CPU supporting socket compatibility with EPYC™ 9004 series in the SP5 socket infrastructure. Based on AMD's new enhanced Zen5 CPU cores with integrated I/O controllers, AMD EPYC™ SOC offers significant performance improvement from current generation production and the best performance per price and lowers TCO through an optimal balance of compute, memory, I/O, and security.

The following lists the features and functions in the AMD Family 1 Ah Models 00h-0Fh and 10H-1FH Socket SP5 processors:

- Compute
  - Zen5 cores:
    - Up to 160 cores with 2 x threads per socket
    - Up to 256 MB L3 shared by 64 cores/CCD
    - 1 MB L2/core, 32/48 KB instruction/data L1 per core
- Memory
  - 12 DDR5 memory channels up to 5200 MT/s (1of 2DPC) and 4400 MT/s (2 of 2DPC)
  - RDIMM
  - Dynamic PPR for non-Chipkill DIMMs
  - Up to 2DPC capacity of 6 TB/socket
- Integrated I/O
  - Up to 128 lanes of High Speed I /O
  - Server Controller Hub (USB, UART, SPI, LPC, I2C, so on)

## Supported processors

The following table shows the 5<sup>th</sup> Generation AMD EPYC 9005 Series processor SKUs that are supported on the R7715.

**Table 17. 5<sup>th</sup> Generation AMD EPYC 9005 Series processor supported in R7715**

Processor	Base Clock Speed (GHz)	Max Clock Speed (GHz)	Cache (M)	Cores	Threads	Memory Speed (MT/s)	Memory Capacity	TDP (W)
9845	2.1	3.7	320	160	320	6400	6 TB	390
9825	2.2	3.7	384	144	288	6400	6 TB	390
9745	2.4	3.7	256	128	256	6400	6 TB	400
9655P	2.6	4.5	384	96	192	6400	6 TB	400
9555P	3.2	4.4	256	64	128	6400	6 TB	360
9575F	3.3	5.0	256	64	128	6400	6 TB	400
9535	4.3	256	64	128	Turbo	6000	6 TB	300
9475F	3.65	4.8	256	48	96	6400	6 TB	400
9455	4.4	256	48	96	Turbo	6000	6 TB	300
9375F	3.85	4.8	256	32	64	6400	6 TB	320

**Table 17. 5<sup>th</sup> Generation AMD EPYC 9005 Series processor supported in R7715 (continued)**

<b>Processor</b>	<b>Base Clock Speed (GHz)</b>	<b>Max Clock Speed (GHz)</b>	<b>Cache (M)</b>	<b>Cores</b>	<b>Threads</b>	<b>Memory Speed (MT/s)</b>	<b>Memory Capacity</b>	<b>TDP (W)</b>
9335	3.0	4.4	128	32	64	6400	6 TB	210
9355P	3.55	4.4	256	32	64	6400	6 TB	280
9275F	4.1	4.8	256	24	48	6400	6 TB	320
9255	3.2	4.3	128	24	48	6400	6 TB	200
9175F	4.2	5.0	512	16	32	6400	6 TB	320
9115	2.6	4.1	64	16	32	6400	6 TB	125
9135	3.65	4.3	64	16	32	6400	6 TB	200
9015	3.6	4.1	64	8	16	6400	6 TB	125

# Memory subsystem

## Topics:

- Supported memory
- System memory guidelines
- CXL memory

## Supported memory

The R7715 supports up to 24 DIMMs (12 per channel), with up to 6 TB of memory and speeds of up to 5200 MT/s.

The R7715 supports registered (RDIMMs) which use a buffer to reduce memory loading and provide greater density, allowing for the maximum platform memory capacity. Unbuffered DIMMs (UDIMMs) are not supported.

**Table 18. Memory technology comparison**

Feature	PowerEdge R7715 (DDR5)
DIMM type	RDIMM
Transfer speed	5200 MT/s for 1 DPC and 4400 MT/s for 2 DPC  <b>NOTE:</b> Maximum DIMM transfer speed support dependent on CPU SKU and DIMM population
Voltage	1.1 V

**Table 19. Supported memory matrix**

DIMM type	Rank	Capacity	DIMM rated voltage and speed	Operating Speed	
				1 DIMM per channel (DPC)	2 DIMMs per channel (DPC)
RDIMM	1R	16 GB	DDR5 (1.1 V), 6400 MT/s	5200 MT/s	4400 MT/s
	2 R	32 GB, 64 GB, 96 GB, 128 GB	DDR5 (1.1 V), 6400 MT/s	5200 MT/s	4000 MT/s
	8 R	256 GB	DDR5 (1.1 V), 6400 MT/s	5200 MT/s	4000 MT/s

 **NOTE:** The processor may reduce the performance of the rated DIMM speed.

## System memory guidelines

The PowerEdge R7715 system supports DDR5 registered DIMMs (RDIMMs). System memory holds the instructions that are started by the processor.

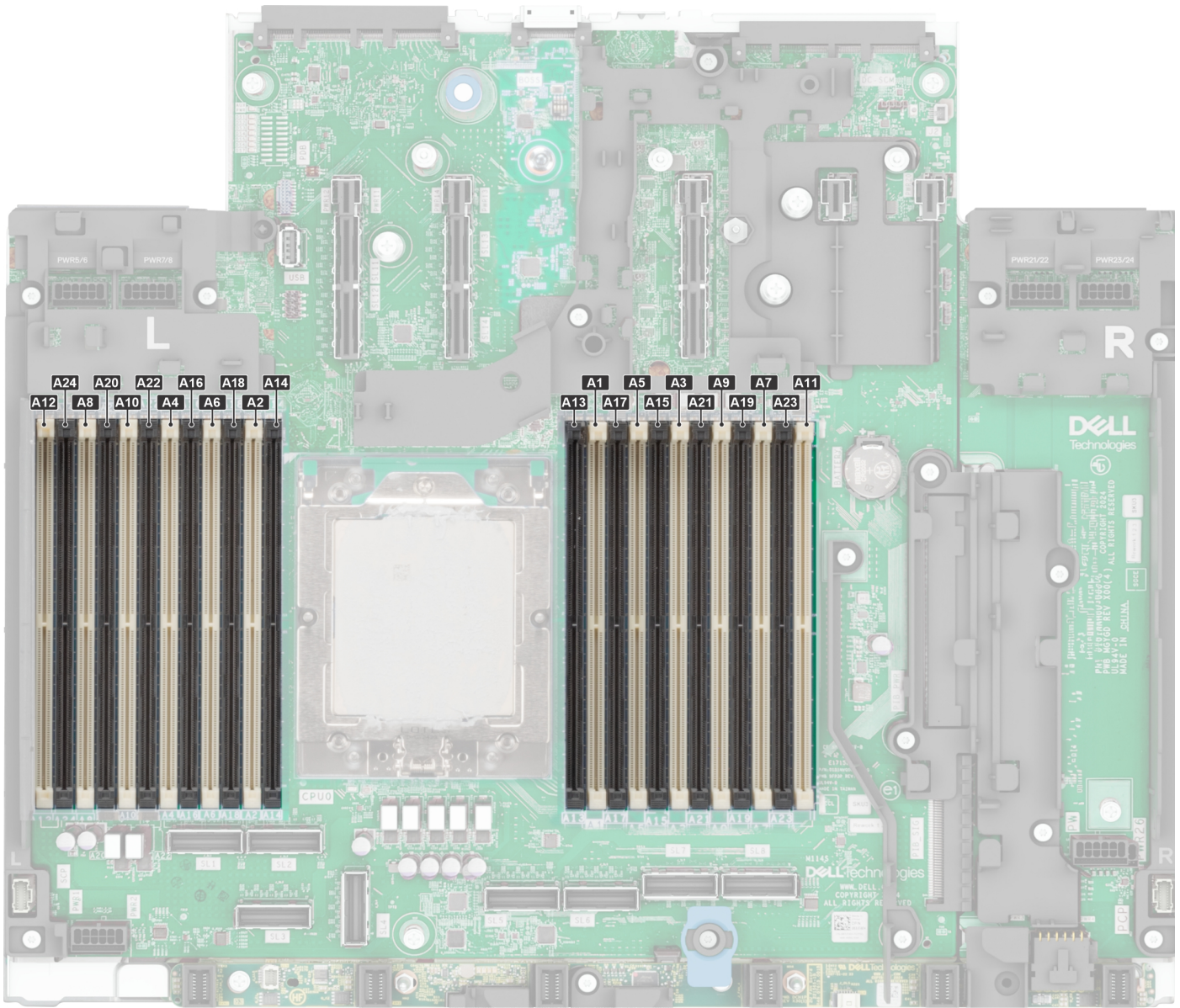

**Figure 22. Memory channels**

Memory channels are organized as follows:

**Table 20. Memory channels**

Processor	Channel A	Channel B	Channel C	Channel D	Channel E	Channel F
Processor 0	Slots A1 and A13	Slots A5 and A17	Slots A3 and A15	Slots A9 and A21	Slots A7 and A19	Slots A11 and A23

**Table 21. Memory channels**

Processor	Channel G	Channel H	Channel I	Channel J	Channel K	Channel L
Processor 0	Slots A2 and A14	Slots A6 and A18	Slots A4 and A16	Slots A10 and A22	Slots A8 and A20	Slots A12 and A24

**Table 22. Supported memory matrix**

DIMM type	Rank	Capacity	DIMM rated voltage and speed	Operating Speed	
				1 DIMM per channel (DPC)	2 DIMMs per channel (DPC)
RDIMM	1R	16 GB	DDR5 (1.1 V), 6400 MT/s	5200 MT/s	4400 MT/s
	2 R	32 GB, 64 GB, 96 GB, 128 GB	DDR5 (1.1 V), 6400 MT/s	5200 MT/s	4000 MT/s
	8 R	256 GB	DDR5 (1.1 V), 6400 MT/s	5200 MT/s	4000 MT/s

**Table 23. Memory Capacity Requirement For Supported GPU Cards**

Recommended System Memory Range (1.5x - 2x GPU Memory)							
GPU Name	GPU Memory	x1 GPU	x2 GPUs	x3 GPUs	x4 GPUs	x5 GPUs	x6GPUs
L4	24 GB	36 - 48 GB	72 - 96 GB	108-144 GB	144 - 192 GB	180 - 240 GB	144 - 288 GB
L40S	48 GB	72 - 96 GB	144 - 192 GB	216 - 288 GB	N/A	N/A	N/A
A16	64 GB	96 - 128 GB	192 - 256 GB	288 - 384 GB	N/A	N/A	N/A
H100NVL	94 GB	141 - 188 GB	282 - 376 GB	423 - 564 GB	N/A	N/A	N/A
H200NVL	141 GB	212 - 282 GB	423 - 564 GB	635 - 846 GB	N/A	N/A	N/A

**NOTE:** The processor may reduce the performance of the rated DIMM speed.

**NOTE:** Maximum DIMM transfer speed support dependent on CPU SKU and DIMM population.

## Memory interleaving with Non-uniform memory access (NUMA)

Non-uniform memory access (NUMA) is a memory design used in multi-processing, where the memory access time depends on the memory location relative to the processor. In NUMA, a processor can access its own local memory faster than the non-local memory.

NUMA nodes per socket (NPS) is a new feature added that allows you to configure the memory NUMA domains per socket. The configuration can consist of one whole domain (NPS1), two domains (NPS2), or four domains (NPS4). In the case of a two-socket platform, an additional NPS profile is available to have whole system memory to be mapped as single NUMA domain (NPS0). For more information on the memory interleaving for NPSx, see the Memory interleaving population rules section in this topic.

BIOS implementation for NPSx

- The BIOS Setup menu presents the applicable NPSx options based on the underlying model number. A change to the current NPSx is communicated to pre-BIOS firmware to take effect on the next boot. The default NPS setting is 1.
- During boot, if the selected NPSx option is not allowed for the model number (for example, if the processor model number changes between reboot), system will halt at the end of POST with UEFI0388 message displayed. On the next reboot, the system will fall back to NPS1 default setting.
- During boot, if the preferred interleaving for the current NPSx is not possible due to memory configuration (for example, the memory population is inconsistent with the preferred interleaving), BIOS shows a warning message UEFI0391.

**Table 24. NPS option and Memory Interleave**

NPS Option	CCD Configuration	Memory Interleaving	Server Package (12 memory channels)
NPS4: Four NUMA nodes per socket, one node per quadrant.	Symmetric configuration across all quadrants of the SoC.	Firmware will attempt to interleave all memory channels on each Quadrant of the SoC.	3- way interleave per node: {ABD}, {CEF}, {GHK}, and {IKL}

**Table 24. NPS option and Memory Interleave (continued)**

NPS Option	CCD Configuration	Memory Interleaving	Server Package (12 memory channels)
NPS2: Two NUMA nodes per socket, one node per left/right half of the SoC.	Requires symmetrical CCD configuration across left/right halves of the SoC.	Firmware will attempt to interleave all memory channels on each Half of the SoC.	6-way Interleave per Node: {ABCDEF} and {GHIJKL}
NPS1: One NUMA node per socket.	Available for any CCD configuration in the SoC. Default configuration	Firmware will attempt to interleave all memory channels in the Socket.	12-way Interleave per Socket: {ABCDEFGHIJKL}
NPS0: One NUMA node per system.	Available on dual processor systems only.	Firmware will attempt to interleave all memory channels in the System.	24-way Interleave per System: {ABCDEFGHIJKL} from each socket

**NOTE:**

1. If the CCD configuration is altered by software (e.g., BIOS Setup Option), NPS4 or NPS2 configurations may not be available, based on the Symmetry requirements noted above.
2. Not all OPNs support NPS2 or NPS4, based on CCD configuration per package.

## CXL memory

**Table 25. CXL memory**

Platform	RC#	CPU0 Port	CPU1 Port	Native DIMM configuration	Total Native DIMM capacity	CXL AIC configuration	Total system memory capacity
R7715	RC7	P0 (x8 + x8)	N/A	24 x 96 GB	2304 GB	2 x AIC (96 GB x 4)	3072 GB
R7715	RC7	P0 (x8 + x8)	N/A	24 x 128 GB	3072 GB	2 x AIC (128 GB x 4)	4096 GB
R7715	RC7	P0 (x8 + x8)	N/A	24 x 256 GB	6144 GB	2 x AIC (96 GB x 4)	6912 GB

**NOTE:**

- Only the above Native DIMM configurations are supported.
- CXL requires fully populated Native DIMMs.
- Cannot select under 4x DIMMs on AIC.
- Cannot support more than two AICs per CPU.
- 256 GB within AIC cannot be thermally supported.

# Storage

## Topics:

- Storage controllers
- Supported Drives
- Internal storage configuration
- Boot Optimized Storage Solution (BOSS)

## Storage controllers

Dell RAID controller options offer performance improvements, including the fPERC solution. fPERC provides a base RAID HW controller without consuming a PCIe slot by using a small form factor and high-density connector to the base planar.

**NOTE:** The size of the RAID 1 drives must be less than that of the secondary RAID containers.

**Table 26. PERC Series controller offerings**

Performance Level	Controller and Description
Premium Performance	H975i Avenger 2 Memory: 1 GB DDR4 2400 MT/s Cache Memory 192 MB x16 PCIe 5.0 at 32 Gbps
	H965i Avenger 1 Memory: 8GB DDR4 3200 MT/s DC-MHS form factor x16 PCIe 4.0 PCIe 4 at 16 Gbps
	H365i Avenger 1 X8 PCIe 4.0 at 16Gbps
	HBA465e Avenger 1 X16 PCIe 4.0 at 16Gbps
	H965e Avenger 1 Memory: 8 GB DDR4 3200 MT/s

**Table 26. PERC Series controller offerings (continued)**

Performance Level	Controller and Description
	x16 PCIe 4,0 at 16 Gbps

- NOTE:** PowerEdge does not support Tri-Mode, the mixing of SAS, SATA, and NVMe behind the same controller.
- NOTE:** For more information about the features of the Dell PowerEdge RAID controllers (PERC), Software RAID controllers, or BOSS cards, and on deploying the cards, see the storage controller documentation at [Storage Controller Manuals](#).
- NOTE:** For the ESXi operating system, H975i is supported on 9.0 or later versions.

## Supported Drives

The table that is shown below lists the internal drives that are supported in system. See Agile for the latest SDL.

**Table 27. Supported drives**

Form Factor	Type	Speed	Rotational Speed	Capacities
2.5 inches	SATA SSD	6 Gbps	SSD	480 GB, 960 GB, 1.92 TB, 3.84 TB
2.5 inches	SAS HDD	12 Gbps	10K	600 GB, 1.2 TB, 2.4 TB
3.5 inches	SATA HDD	6 Gbps	7.2K	2 TB, 4 TB, 8 TB, 12 TB, 16 TB, 20 TB, 24 TB, 32 TB*
3.5 inches	SAS HDD	12 Gbps	7.2K	2 TB, 4 TB, 8 TB, 12 TB, 16 TB, 20 TB, 24 TB, 32 TB*
2.5 inches	NVMe	Gen5	SSD	1.92 TB, 3.84 TB, 7.68 TB, 15.36 TB, 30.72 TB, 61.44 TB
EDSFF E3.S NVMe	NVMe	Gen5	SSD	1.6 TB, 1.92 TB, 3.2 TB, 3.84 TB, 6.4 TB, 7.68 TB, 15.36 TB, 30.72 TB, 61.44 TB

- NOTE:** This document provides a comprehensive list of product features. However, features marked with an asterisk (\*) may not be available at launch but introduced in future updates. Please note that this document does not confirm the availability or release timeline of any feature. For the most accurate and up-to-date information on feature availability, please refer to the product configurator page on dell.com.
- NOTE:** \*Feature not available at product launch in November, 2025. Please refer to the product configurator page on Dell.com to confirm feature availability..

## Internal storage configuration

R7715 available internal storage configurations:

- No backplane configuration
- 2 x U.2 Universal SSDs
- 8 x 2.5-inch Universal drives
- 8 x EDSFF E3.S Gen5 NVMe drives
- 12 x 3.5-inch SAS/SATA Universal drives
- 16 x 2.5-inch SAS/SATA SSD + 8 x U.2 NVMe drives
- 16 x 2.5-inch SAS/SATA Universal SSD drives
- 16 x EDSFF E3.S Gen5 NVMe drives
- 24 x 2.5-inch SAS/SATA Universal drives
- 32 x EDSFF E3.S Gen5 NVMe drives
- 40 x EDSFF E3.S Gen5 NVMe drives

# Boot Optimized Storage Solution (BOSS)

BOSS is a RAID solution that is designed to boot operating systems and segregate operating system boot drives from data on server-internal storage.

## BOSS feature matrix

Table 28. BOSS feature matrix

BOSS card	Drive Size	RAID levels	Stripe size	Virtual disk cache function	Maximum number of virtual disks	Maximum number of drives supported	Drive types	PCIe support	Disk cache policy	Support for Non-RAID disks	Cryptographic digital signature to verify firmware payload	Hot Plug
BOSS-N1 DC-MHS Flatbread	M.2 devices are read-intensive with 480 GB or 960 GB capacity.	RAID 1 and RAID 0	Supports default 64 K stripe size only.	None	1	2	M.2 NVMe	Gen3	Drive default	No	Yes	No

**NOTE:** The system can support BOSS in the rear of the system.

# Networking

## Topics:

- [Overview](#)
- [OCP 3.0 support](#)

## Overview

PowerEdge offers a wide variety of options to get information moving to and from our servers. Industry best technologies are chosen and these adapters are rigorously validated for worry-free, fully supported use in Dell servers.

## OCP 3.0 support

**Table 29. OCP 3.0 feature list**

Feature	OCP 3.0
Form factor	SFF
PCIe Gen	Gen 5
Max PCIe width	x16
Max number of ports	4
Port type	BT/SFP/SFP28/QSFP56/QSFP112
Max port speed	400 GbE
NC-SI	Yes, support on embedded slot (Slot10) only.
SNAP I/O	N/A
WoL	Yes
Power consumption	15 W–35 W

## Supported OCP cards

**Table 30. Supported OCP cards**

Form factor	Vendor	Port type	Port speed	Port count
OCP 3.0	Broadcom	BT	1 GbE	4
	Intel	BT	1 GbE	4
	Intel	BT	10 GbE	4
	Broadcom	BT	10 GbE	2
	Broadcom	BT	10 GbE	4
	Intel	BT	10 GbE	2
	Broadcom	SFP28	25 GbE	4

**Table 30. Supported OCP cards (continued)**

Form factor	Vendor	Port type	Port speed	Port count
	Nvidia	SFP28	25 GbE	2
	Broadcom	BT	25 GbE	2
	Broadcom	QSFP56	100 GbE	2
	Nvidia	QSFP56	100 GbE	2
	Broadcom	QSFP56	100 GbE	2
	Broadcom	QSFP56	200 GbE	2

## OCP NIC 3.0 vs 2.0

**Table 31. OCP 3.0 and 2.0 NIC comparison**

Form Factor	OCP 3.0	OCP 2.0 (LOM Mezz)	Notes
PCIe Gen	Gen5	Gen3	Supported OCP3 is SFF (small form factor).
Max PCIe Lanes	Up to x16	Up to x16	See server slot priority matrix.
Shared LOM	Yes	Yes	Only OCP on slot 10 (rear I/O) can support BMC port redirect as shared NIC.
Aux Power	Yes	Yes	Used for Shared LOM

# PCIe subsystem

## Topics:

- PCIe risers

## PCIe risers

Shown below are the riser offerings for the platform.

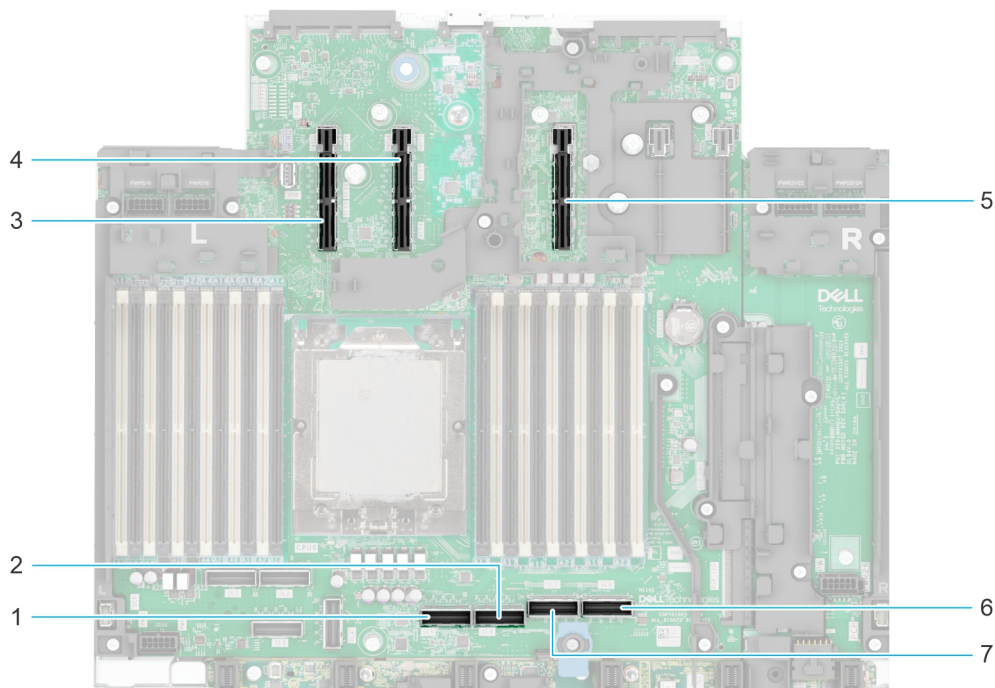

**Figure 23. Riser connector location on the HPM board**

- |   |   |
|---|---|
| 1. PCIe connector 5 (SL5_CPU 0)                                 | 2. PCIe connector 6 (SL6_CPU 0)                                 |
| 3. Riser connector - requires CPU 0 (SL11/SL12/PWR11/<br>PWR12) | 4. Riser connector - requires CPU 0 (SL13/SL14/PWR13/<br>PWR14) |
| 5. Riser connector - requires CPU 0 (SL15/SL16/PWR15/<br>PWR16) | 6. PCIe connector 8 (SL8_CPU 0)                                 |
| 7. PCIe connector 7 (SL7_CPU 0)                                 |   |

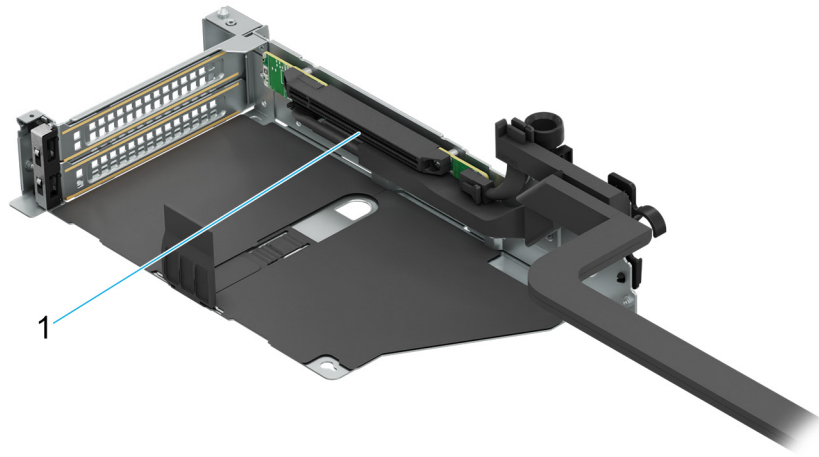

**Figure 24. Riser 1e**

1. Slot 1

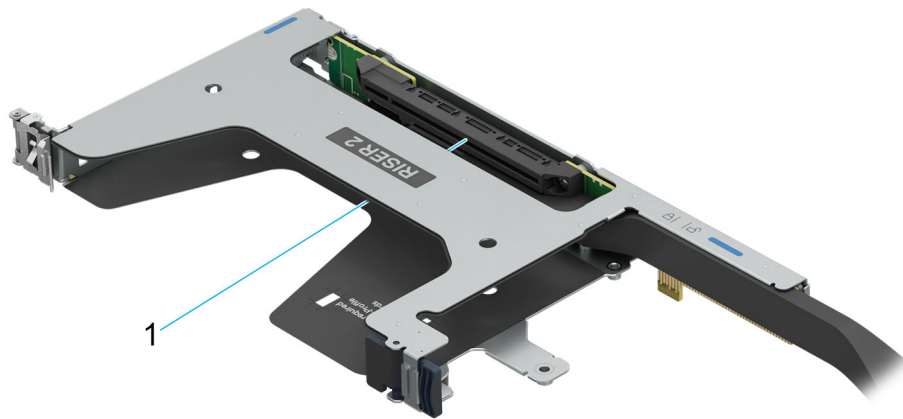

**Figure 25. Riser R2n**

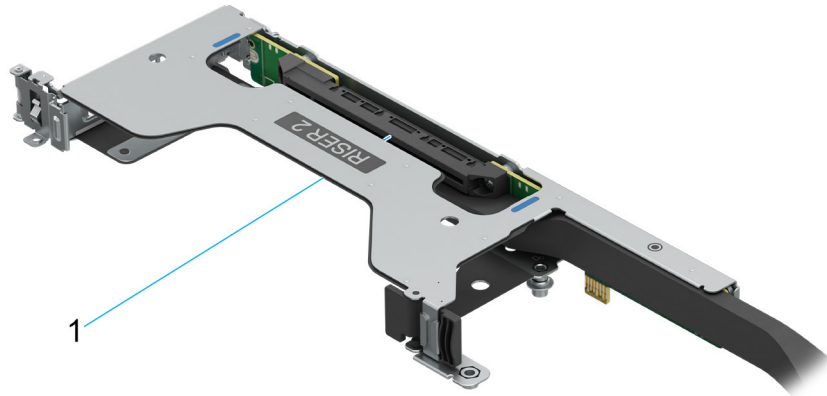

Figure 26. Riser R2m

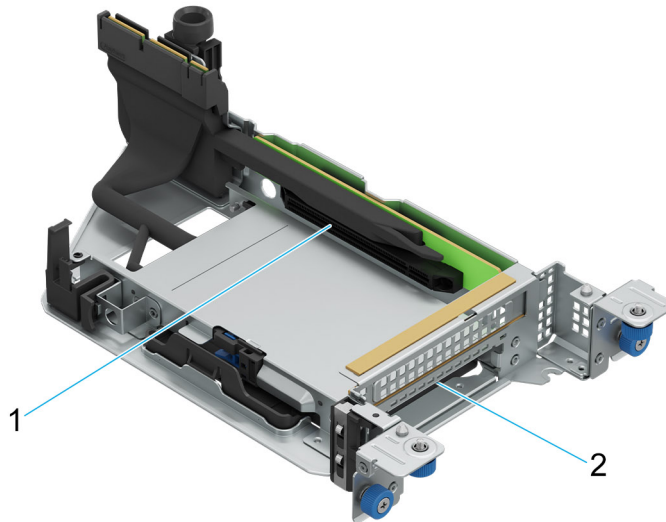

Figure 27. Riser 3e

1. Slot 2

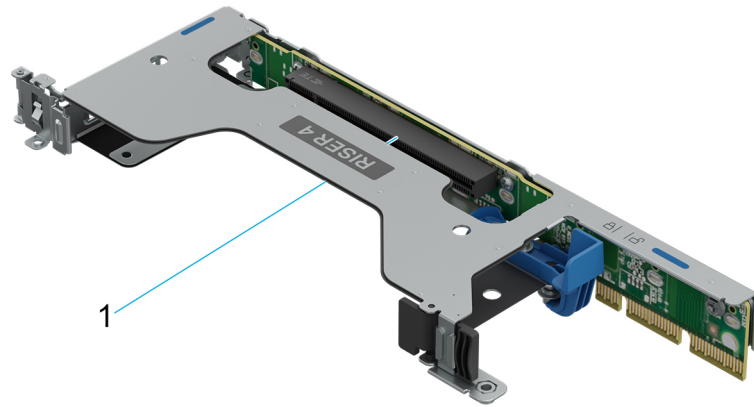

Figure 28. Riser R4a

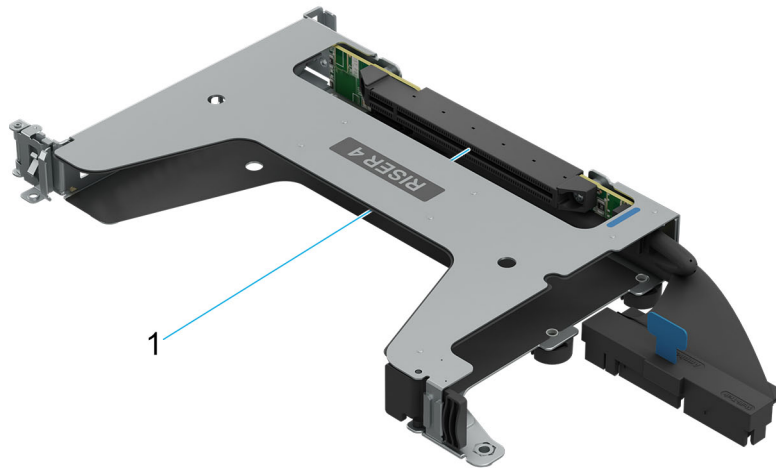
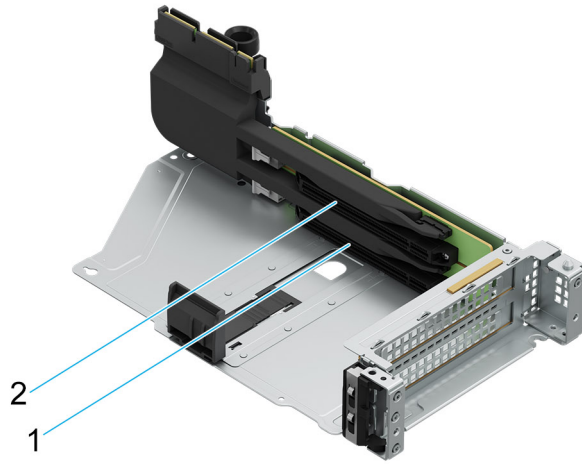

Figure 29. Riser 4b

1. Slot 1



**Figure 30. Riser 5b**

1. Slot 1
2. Slot 2

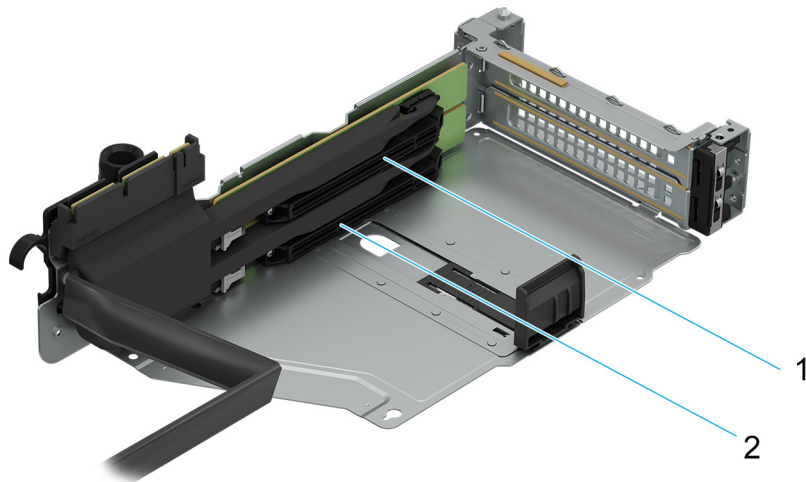

**Figure 31. Riser R5f**

1. Slot 7
2. Slot 8

**Table 32. PCIe Riser Configurations**

Config No.	Riser configuration	No. of Processors	PERC type supported	Rear storage possible
1	R3b+R5b	1	Front PERC	No
2	R3e+R4b+R5b	1	Front PERC	No
3	R1e+R2n+R3e+R4b+R5b	1	Front PERC	No
4	R1e+R3e+R4a+R5b	1	Front PERC	No
5	R1e+R2n+R3b+R4b+R5f	1	Front PERC	No
7	R1d+R2n+R3a+R4b+R5a	1	Front PERC	No

**Table 32. PCIe Riser Configurations (continued)**

<b>Config No.</b>	<b>Riser configuration</b>	<b>No. of Processors</b>	<b>PERC type supported</b>	<b>Rear storage possible</b>
8	R1e+R2m=R3b+R4a+R5b	1	Front PERC	No

# Power, thermal, and acoustics

PowerEdge servers have an extensive collection of sensors that automatically track thermal activity, which helps to regulate temperature by reducing server noise and power consumption. The table below lists the tools and technologies Dell offers to lower power consumption and increase energy efficiency.

## Topics:

- [Power](#)
- [Thermal](#)
- [Acoustics](#)

## Power

**Table 33. Power tools and technologies**

Feature	Description
Power Supply Units(PSU) portfolio	Dell's PSU portfolio includes intelligent features such as dynamically optimizing efficiency while maintaining availability and redundancy. Find additional information in the Power supply units section.
Tools for right sizing	Enterprise Infrastructure Planning Tool (EIPT) is a tool that can help you determine the most efficient configuration possible. With Dell's EIPT, you can calculate the power consumption of your hardware, power infrastructure, and storage at a given workload. Learn more at <a href="#">Dell EIPT</a> .
Industry Compliance	Dell's servers are compliant with all relevant industry certifications and guide lines, including 80 PLUS, Climate Savers and ENERGY STAR.
Power monitoring accuracy	PSU power monitoring improvements include: <ul style="list-style-type: none"> <li>• Dell's power monitoring accuracy is currently 1%, whereas the industry standard is 5%</li> <li>• More accurate reporting of power</li> </ul>
Rack infrastructure	Dell offers some of the industry's highest-efficiency power infrastructure solutions, including: <ul style="list-style-type: none"> <li>• <a href="#">Power distribution units (PDUs)</a></li> <li>• <a href="#">Uninterruptible power supplies (UPSs)</a></li> <li>• <a href="#">Energy Smart containment rack enclosures</a></li> <li>• AC Blind Mate</li> </ul> Find additional information at: <a href="#">Power and Cooling</a>

## Power Supply Units

Energy Smart power supplies have intelligent features, such as the ability to dynamically optimize efficiency while maintaining availability and redundancy. Also featured are enhanced power-consumption reduction technologies, such as high-efficiency power conversion and advanced thermal-management techniques, and embedded power-management features, including high-accuracy power monitoring. The table below shows the power supply unit options that are available for the system.

**Table 34. PSU specifications**

PSU	Class	Heat dissipation (maximum) (BTU/hr)	Frequency (Hz)	Input voltage	Current (A)
3200 W Titanium	Titanium	12000	50/60	200-240 Vac	16

**Table 34. PSU specifications (continued)**

PSU	Class	Heat dissipation (maximum) (BTU/hr)	Frequency (Hz)	Input voltage	Current (A)
	N/A	12000	N/A	240 Vdc	14.5
3200 W 277 Vac and HVDC	Titanium	12000	50/60Hz	277 Vac	12.9
	N/A	12000	N/A	366 Vdc	10.47
2400 W Titanium	Titanium	9000	50/60Hz	100-240 Vac	16-13.2
	N/A	9000	N/A	240 Vdc	10.9
1800 W Titanium *	Titanium	6750	50/60	200-240 Vac	9.8-8.2
	N/A	6750	N/A	240 Vdc	8.2
1500 W Titanium	Titanium	5625	50/60	100-240 Vac	12-8.2
	N/A	5625	N/A	240 Vdc	6.8
1500 W 277 Vac and HVDC	Titanium	5621	50/60	277 Vac	6.1
	N/A	5621	N/A	336 Vdc	4.91
1400 W -48 Vdc	Telco	5310	N/A	(-48) - (-60) Vdc	33
1100 W Titanium	Titanium	4125	50/60	100-240 Vac	12-6.1
	N/A	4125	N/A	240 Vdc	5.1
1100 W Platinum	Platinum	4125	50/60	100-240 Vac	12-6.1
	N/A	4125	N/A	240 Vdc	5.1
800 W Titanium	Titanium	3000	50/60	100-240 Vac	9.2-4.5
	N/A	3000	N/A	240 Vdc	3.7
800 W Platinum	Platinum	3000	50/60	100-240 Vac	9.2-4.5
	N/A	3000	N/A	240 Vdc	3.7

- NOTE:** This document provides a comprehensive list of product features. However, features marked with an asterisk (\*) may not be available at launch but introduced in future updates. Please note that this document does not confirm the availability or release timeline of any feature. For the most accurate and up-to-date information on feature availability, please refer to the product configurator page on dell.com.
- NOTE:** \* Feature not available at product launch in November,2025. Please refer to the product configurator page on Dell.com to confirm feature availability.
- NOTE:** If a system with AC 1500 W and 1100 W PSUs operates at low line 100-120 Vac, then the power rating per PSU is de-rated to 1050 W.



**Figure 32. C13 power cord**



**C19**

Figure 33. C19 Power cord



**C16**

Figure 34. C16 Power Cord

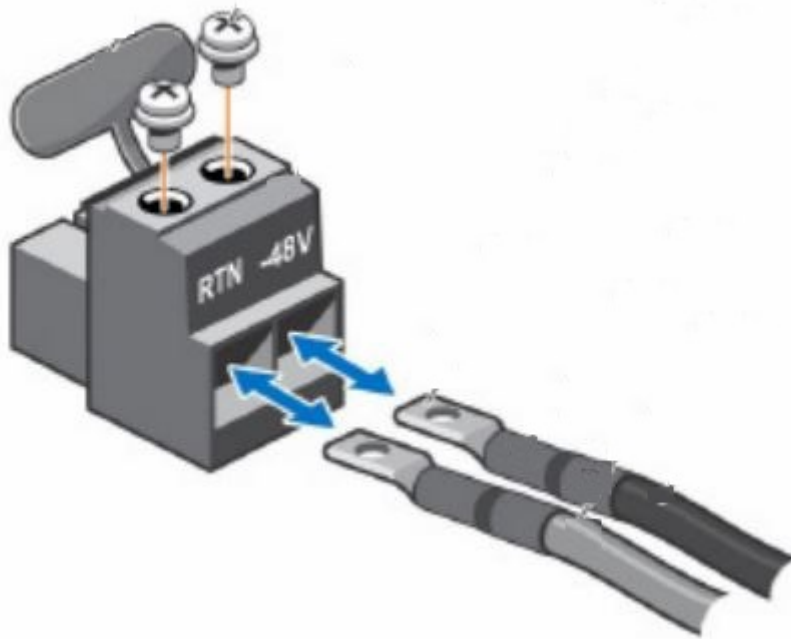

Figure 35. DC PSU power cord\*

Table 35. PSU power cables

Form factor	Output	Power cable
Redundant 73.5 mm	3200 W Titanium mixed mode	C19
Redundant 73.5 mm	3200 W 277 Vac and HVDC	APP/Saf-D-Grid
Redundant 73.5 mm	2400 W Titanium mixed mode	C19
Redundant 60 mm	1800 W Titanium mixed mode*	C16

**Table 35. PSU power cables (continued)**

Form factor	Output	Power cable
Redundant 60 mm	1500 W Titanium mixed mode	C13
Redundant 60 mm	1500 W 277 Vac and HVDC	APP/Saf-D-Grid
Redundant 60 mm	1400 W Telco	DC power cable
Redundant 60 mm	1100 W Titanium mixed mode	C13
Redundant 60 mm	1100 W Platinum mixed mode	C13
Redundant 60 mm	800 W Titanium mixed mode	C13
Redundant 60 mm	800 W Platinum mixed mode	C13

**NOTE:** This document provides a comprehensive list of product features. However, features marked with an asterisk (\*) may not be available at launch but introduced in future updates. Please note that this document does not confirm the availability or release timeline of any feature. For the most accurate and up-to-date information on feature availability, please refer to the product configurator page on dell.com.

**NOTE:** \*Feature not available at product launch in November, 2025. Please refer to the product configurator page on Dell.com to confirm feature availability.

## Thermal

PowerEdge servers have an extensive collection of sensors that automatically track thermal activity, which helps regulate temperature thereby reducing server noise and power consumption.

### Thermal design

Thermal management of the platform helps deliver high performance with the right amount of cooling to components, while maintaining the lowest fan speeds possible. This is done across a wide range of ambient temperatures from 10°C to 35°C (50°F to 95°F) and to extended ambient temperature ranges.

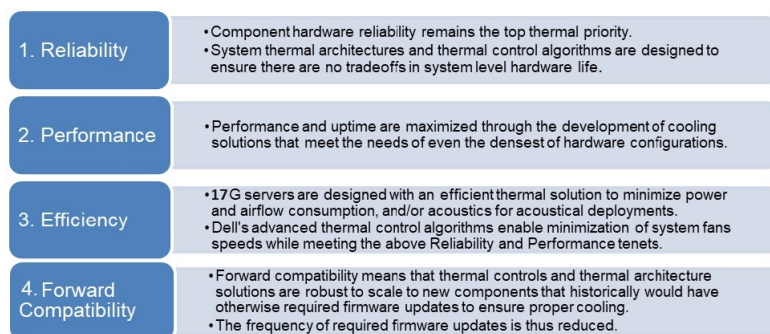

**Figure 36. Thermal design characteristics**

The thermal design of the PowerEdge R7715 reflects the following:

- Optimized thermal design: The system layout is architected for optimum thermal design.
- System component placement and layout are designed to provide maximum airflow coverage to critical components with minimum expense of fan power.
- Comprehensive thermal management: The thermal control system regulates the fan speed based on several different responses from all system-component temperature sensors, and inventory for system configurations. Temperature monitoring includes components such as processors, DIMMs, chipset, the inlet air ambient, hard disk drives, and OCP.
- Open and closed loop thermal fan speed control: Open loop thermal control uses system configuration to determine fan speed based on inlet air ambient temperature. Closed loop thermal control method uses feedback temperatures to dynamically determine proper fan speeds.

- User-configurable settings: With the understanding and realization that every customer has unique set of circumstances or expectations from the system. For more information, see the Dell PowerEdge R7715 Installation and Service Manual at [PowerEdge Manuals](#) and “Advanced Thermal Control: Optimizing across Environments and Power Goals” on Dell.com.
- Cooling redundancy: The R7715 allows N+1 fan redundancy, allowing continuous operation with one fan failure in the system.
- Environmental Specifications: The optimized thermal management makes the R7715 reliable under a wide range of operating environments.

## Acoustics

### Acoustical configurations of R7715

Dell PowerEdge R7715 is a rack or tower server appropriate for attended data center environment. However, lower acoustical output is attainable with proper hardware or software configurations.

**Table 36. Configurations tested for acoustical experience**

R7715 Configurations	Low	Typical - 3.5"	Typical - 2.5"	NVMe	E3	GPU
System fan type	HPR Silver Fan (Sirocco Fan)	HPR Gold Fan (VHP Fan)	HPR Silver Fan (Sirocco Fan)	HPR Silver Fan (Sirocco Fan)	HPR Gold Fan (VHP Fan)	HPR Platinum Fan (Brisa Fan)
CPU	1x (155,195W) Group C	1x(200, 240W) Group B	1x (240, 300W)Group A	1x (240, 300W)Group A	1x (320, 400W)Group E	1x (240, 300W)Group A
Memory	12 x 16GB RDIMM DDR5	24 x 16GB RDIMM DDR5	24 x 64GB RDIMM DDR5	24 x 96GB RDIMM DDR5	24 x 96GB RDIMM DDR5	24 x 128GB RDIMM DDR5
HDD/SSD	8 x 2.5" HDD	12 x 3.5" HDD	16 x 2.5" HDD	16 x 2.5" SAS/ SATA+ 8x U.2	8 x E3.s SSD	32 x E3.s SSD
BP	8 x 2.5" BP	12 x 3.5"	16 x 2.5"	24 x 2.5"	16 x E3.s	32 x E3.s
PERC	None	PERC 12	PERC 12	PERC 12	None	None
BOSS	17G BOSS	17G BOSS	17G BOSS	17G BOSS	17G BOSS	17G BOSS
OCP	1 x OCP(x16) - 1Gbx4	2 x OCP(x16) - 10 GbE	None	None	None	2 x OCP(x16) - 100 GbE
PSU	1 x 800W	2 x 1100W	2 x 1500W	2 x 1500W	2 x 1500W	2 x 3200W
Bezel	Yes	Yes	Yes	Yes	Yes	Yes
PCIe 1	N/A	N/A	N/A	N/A	N/A	2x DW Cards (Max 450W)
PCIe 2	N/A	N/A	N/A	N/A	N/A	N/A
PCIe 3	N/A	N/A	N/A	N/A	N/A	N/A

**Table 37. Acoustical experience of R7715 configurations**

Configuration	The Quietest Configuration	Low	Typical - 3.5"	Typical - 2.5"	NVMe	E3	GPU
Acoustical Performance: Idle/ Operating @ 25 °C Ambient							
L <sub>wA,m</sub> (B)	Idle <sup>(4)</sup>	5.3	5.3	6.0	6.4	6.3	7.2
	Operating / Customer Usage	5.5	5.5	6.0	6.4	6.3	7.2

**Table 37. Acoustical experience of R7715 configurations (continued)**

Configuration		The Quietest Configuration	Low	Typical - 3.5"	Typical - 2.5"	NVMe	E3	GPU
	Operating (5)(6)							
K <sub>v</sub> (B)	Idle <sup>(4)</sup>	0.4	0.4	0.4	0.4	0.4	0.4	0.4
	Operating / Customer Usage Operating (5)(6)	0.4	0.4	0.4	0.4	0.4	0.4	0.4
L <sub>pA,m</sub> (dB)	Idle <sup>(4)</sup>	40	40	46	52	50	57	60
	Operating / Customer Usage Operating (5)(6)	40	41	46	52	50	57	60
Prominent discrete tones (3)		TBD	Prominence ratio < 15 dB					
Acoustical Performance: Idle @ 28 °C Ambient								
L <sub>wA,m</sub> <sup>(1)</sup> (B)		5.5	5.5	6.3	6.6	6.5	7.1	7.6
K <sub>v</sub> (B)		0.4	0.4	0.4	0.4	0.4	0.4	0.4
L <sub>pA,m</sub> <sup>(2)</sup> (B)		41	41	49	54	53	59	61
Acoustical Performance: Max. Loading @ 35 °C Ambient								
L <sub>wA,m</sub> <sup>(1)</sup> (B)		6.1	6.1	7.8	7.1	7.4	9.1	9.5
K <sub>v</sub> (B)		0.4	0.4	0.4	0.4	0.4	0.4	0.4
L <sub>pA,m</sub> <sup>(2)</sup> (dB)		48	48	63	56	58	74	77

**L<sub>wA,m</sub>:** The declared mean A-weighted sound power level (L<sub>wA</sub>) is calculated per section 5.2 of ISO 9296 (2017) with data collected using the methods described in ISO 7779 (2010). Data presented here may not be fully compliant with ISO 7779.

**L<sub>pA,m</sub>:** The declared mean A-weighted emission sound pressure level is at the bystander position per section 5.3 of ISO 9296 (2017) and measured using methods described in ISO 7779 (2010). The system is placed on a standard table, 75cm above a reflective floor. Data presented here may not be fully compliant with ISO 7779.

**Prominent tones:** Criteria of Annex D of ECMA-74 and Sections 12.6 and 12.8 of ECMA-418-1 are followed to determine if discrete tones are prominent and to report them, if so.

**Idle mode:** The steady-state condition in which the server is energized but not operating any intended function.

**Operating mode:** The maximum of the steady state acoustical output at 50% of CPU TDP or active HDDs per C.9.3.2 in ECMA-74 (17<sup>th</sup> ed., Dec. 2019).

# Rack, rails, and cable management

## Topics:

- [Rails and cable management information](#)

## Rails and cable management information

The rail offerings for the PowerEdge R7715 consist of two general types: sliding and static. The cable management offerings consist of an optional cable management arm (CMA) and an optional strain relief bar (SRB).

See the *Enterprise Systems Rail Sizing and Rack Compatibility Matrix* available at [Dell Technologies Enterprise Systems Rail Sizing and Rack Compatibility Matrix](#) for information regarding:

- Specific details about rail types.
- Rail adjustability ranges for various rack mounting flange types.
- Rail depth with and without cable management accessories.
- Rack types that are supported for various rack mounting flange types.

Key factors governing proper rail selection include the following:

- Spacing between the front and rear mounting flanges of the rack.
- Type and location of any equipment that is mounted in the back of the rack such as power distribution units (PDUs).
- Overall depth of the rack.

## Sliding rails features summary

The sliding rails allow the system to be fully extended out of the rack for service. There are two types of sliding rails available, ReadyRails II sliding rails and Stab-in/Drop-in sliding rails. The sliding rails are available with or without the optional cable management arm (CMA) or strain relief bar (SRB).

### B21 ReadyRails sliding rails for 4-post racks

- Supports drop-in installation of the chassis to the rails.
- Support for tool-less installation in 19" EIA-310-E compliant square or unthreaded round hole 4-post racks including all generations of the Dell racks.
- Support for tooled installation in 19" EIA-310-E compliant threaded hole 4-post racks.
- Support full extension of the system out of the rack to allow serviceability of key internal components.
- Support for optional strain relief bar (SRB).
- Support for an optional cable management arm (CMA).

**NOTE:** For situations where CMA support is not required, the outer CMA mounting brackets can be uninstalled from the sliding rails. This reduces the overall length of the rails and eliminates the potential interference with rear-mounted PDUs or the rear rack door.

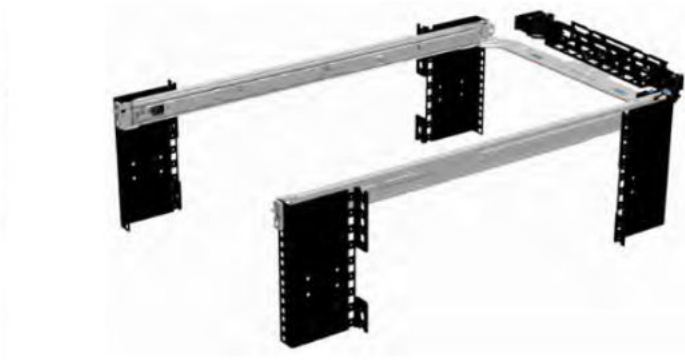

Figure 37. Sliding rails with optional CMA



Figure 38. Sliding rails with optional SRB

#### B22 Stab-in/Drop-in sliding rails for 4-post racks

- Supports drop-in or stab-in installation of the chassis to the rails.
- Support for tool-less installation in 19" EIA-310-E compliant square, unthreaded round hole racks including all generations of the Dell racks. Also, support tool-less installation in threaded round hole 4-post racks.
- Support for tool-less installation in Dell Titan or Titan-D racks.
- Support full extension of the system out of the rack to allow serviceability of key internal components.
- Support for an optional cable management arm (CMA).
- Support for optional strain relief bar (SRB).

**i NOTE:** For situations where CMA support is not required, the outer CMA mounting brackets can be uninstalled from the sliding rails. This reduces the overall length of the rails and eliminates the potential interference with rear-mounted PDUs or the rear rack door.

## B20 static rails summary

The static rails offer a greater adjustability range and a smaller overall mounting footprint than the sliding rails because of their reduced complexity and lack of need for CMA support. The static rails support a wider variety of racks than the sliding rails. However, they do not support serviceability in the rack and are thus not compatible with the CMA. The static rails are also not compatible with SRB.



**Figure 39. Static rails**

### Static rails features summary

Static rails for 4-post and 2-post racks:

- Supports Stab-in installation of the chassis to the rails.
- Support tool-less installation in 19" EIA-310-E compliant square or unthreaded round hole 4-post racks including all generations of Dell racks.
- Support tooled installation in 19" EIA-310-E compliant threaded hole 4-post and 2-post racks.
- Support for tooled installation in Dell Titan or Titan-D rack.

#### **NOTE:**

- Screws are not included with the static rail kit since racks are offered with various thread types. The screws are provided for mounting static rails in racks with threaded mounting flanges.
- Screw head diameter should be 10 mm or less.

### 2-Post racks installation

If installing to 2-Post (Telco) racks, the ReadyRails II static rails (B20) must be used. Sliding rails support mounting in 4-post racks only.



**Figure 40. Static rails in 2-post center mount configuration**

#### **Installation in the Dell Titan or Titan-D racks**

For tool-less installation in the Dell Titan or Titan-D racks, the Stab-in/Drop-in sliding rails (B22) must be used. This rail collapses down sufficiently to fit in the rack with mounting flanges that are spaced about 24 inches apart from front to back. The Stab-in/Drop-in sliding rail allows bezels of the servers and storage systems to be aligned when installed in these racks. For tooled installation, Stab-in Static rails (B20) must be used for bezel alignment with storage systems.

### Cable management arm (CMA)

The optional cable management arm (CMA) organizes and secures the cords and cables exiting the back of the systems. It unfolds to allow the systems to extend out of the rack without having to detach the cables. Some key features of the CMA include:

- Large U-shaped baskets to support dense cable loads.
- Open vent pattern for optimal airflow.
- Ability to mount on either side by swinging the spring-loaded brackets from one side to the other.
- Utilizes hook-and-loop straps rather than plastic tie wraps to eliminate the risk of cable damage during cycling.
- Includes a low-profile fixed tray to both support and retain the CMA in its fully closed position.
- Both the CMA and the tray mount without the use of tools by simple and intuitive snap-in designs.

The CMA can be mounted to either side of the sliding rails without the use of tools or the need for conversion. For systems with one power supply unit (PSU), it is recommended to mount on the side opposite to that of the power supply to allow easier access to it and the rear drives (if applicable) for service or replacement.

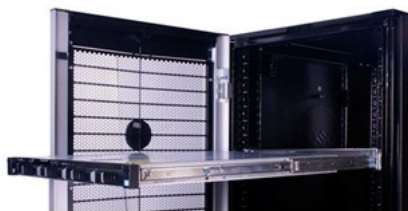

**Figure 41. Sliding rails with CMA**

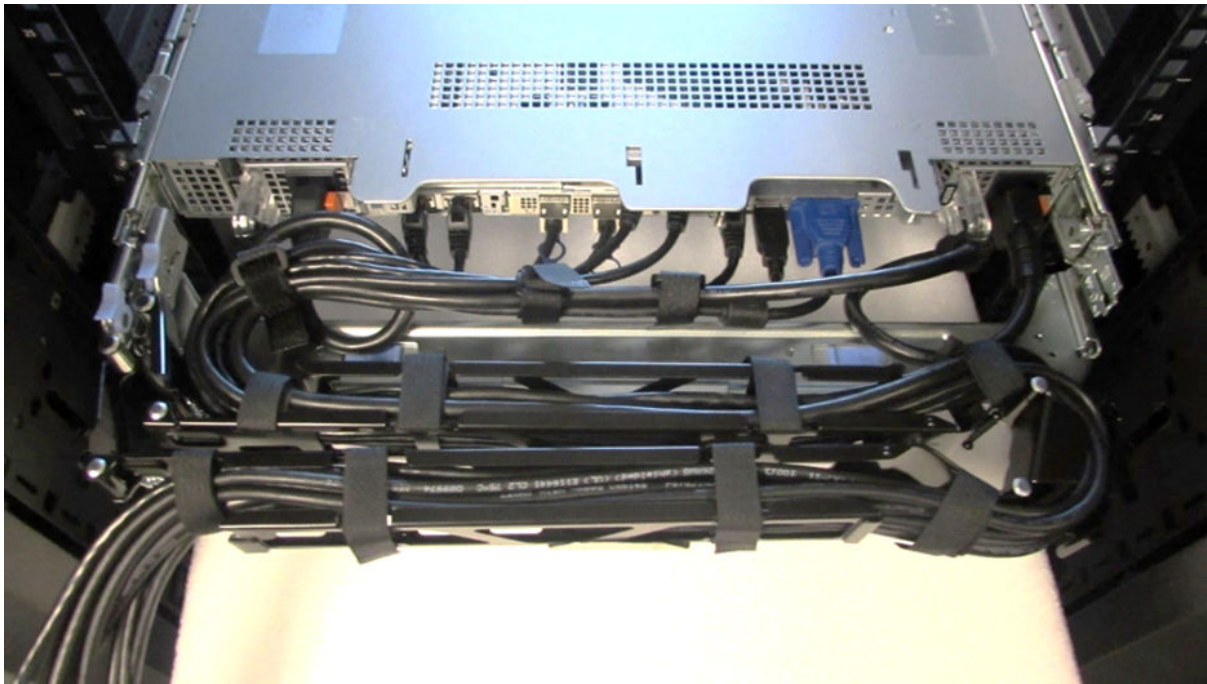

**Figure 42. CMA Cabling**

## Strain Relief Bar (SRB)

The optional strain relief bar (SRB) for the PowerEdge R7715 organizes and supports cable connections at the rear end of the server to avoid damage from bending.

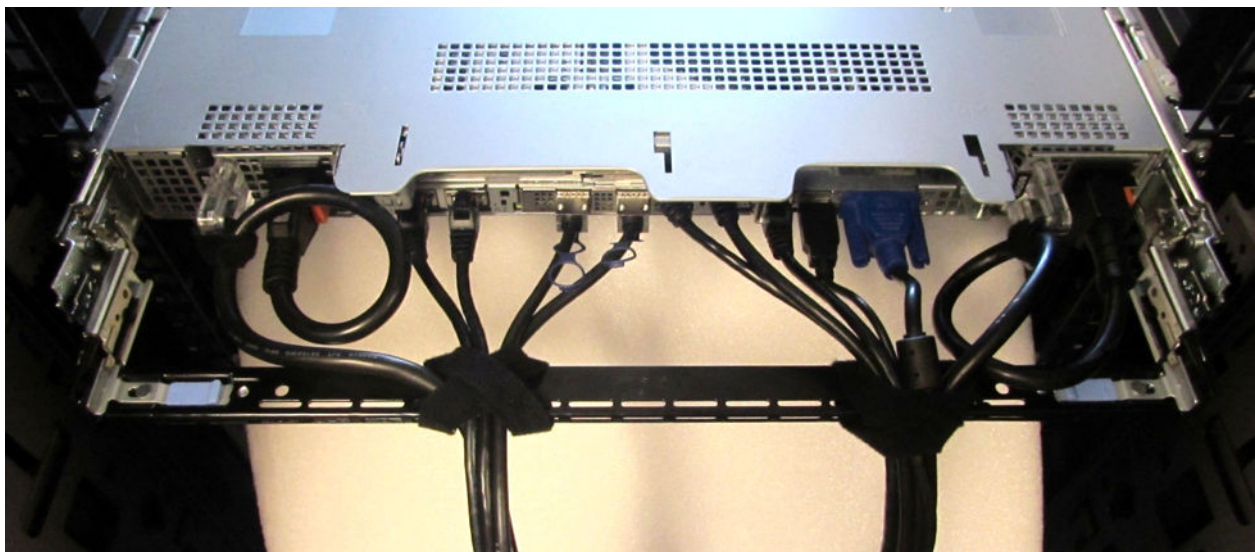

**Figure 43. Cabled strain relief bar**

- Tool-less attachment to the rails
- Two depth positions to accommodate various cable loads and rack depths.
- Supports cable loads and controls stresses on server connectors.
- Cables can be segregated into discrete purpose-specific bundles.

## Rack Installation

Drop-in design means that the system is installed vertically into the rails by inserting the standoffs on the sides of the system into the J-slots in the inner rail members with the rails in the fully extended position. The recommended method of installation is to first insert the rear standoffs on the system into the rear J-slots on the rails to free up a hand and then rotate the system down into the remaining J-slots while using the free hand to hold the rail against the side of the system.

Stab-in design means that the inner (chassis) rail members must first be attached to the sides of the system and then inserted into the outer (cabinet) members installed in the rack.

### Installing the system into the rack (option A: Drop-In)

1. Pull the inner rails out of the rack until they lock into place.



**Figure 44. Pull out inner rail**

2. Locate the rear rail standoff on each side of the system and lower them into the rear J-slots on the slide assemblies.
3. Rotate the system downward until all the rail standoffs are seated in the J-slots.

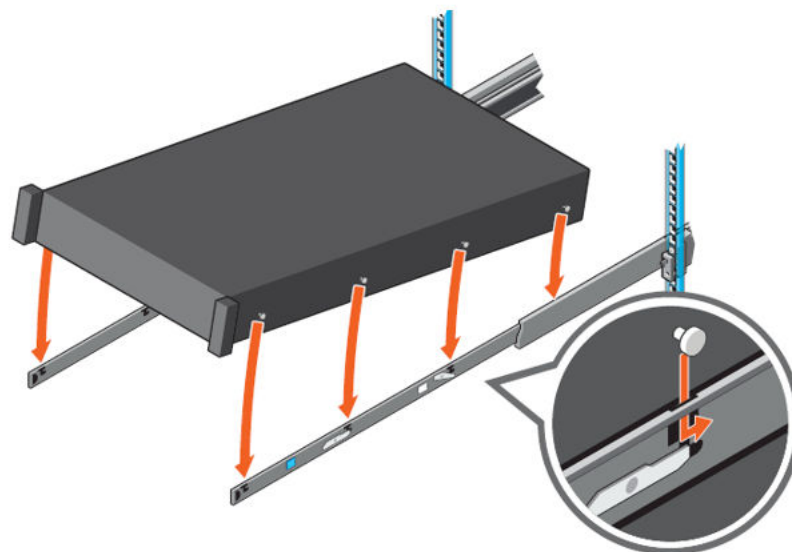

**Figure 45. Rail standoffs seated in J-slots**

4. Push the system inward until the lock levers click into place.
5. Pull the blue side release lock tabs forward or backward on both rails and slide the system into the rack until the system is in the rack.

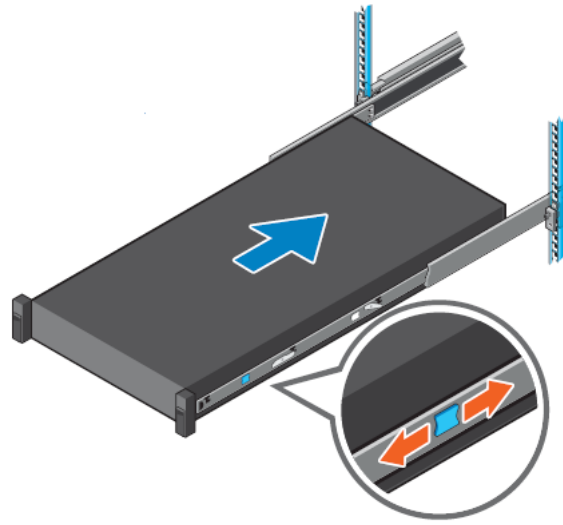

**Figure 46. Slide system into the rack**

### Installing the system into the rack (option B: Stab-In)

1. Pull the intermediate rails out of the rack until they lock into place.
2. Release the inner rail lock by pulling forward on the white tabs and sliding the inner rail out of the intermediate rails.

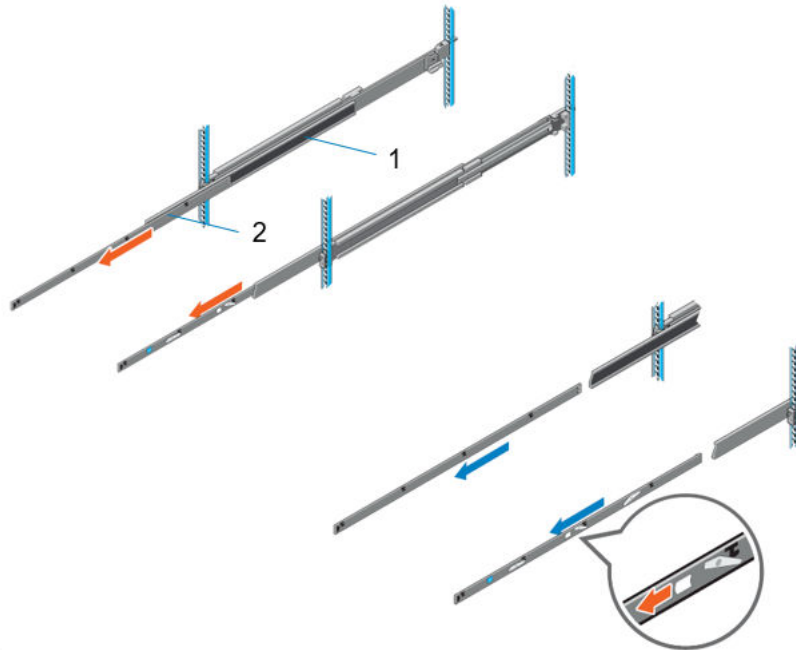

**Figure 47. Pull out the intermediate rail**

**Table 38. Rail component label**

Number	Component
1	Intermediate rail

**Table 38. Rail component label (continued)**

Number	Component
2	Inner rail

3. Attach the inner rails to the sides of the system by aligning the J-slots on the rail with the standoffs on the system and sliding forward on the system until they lock into place.

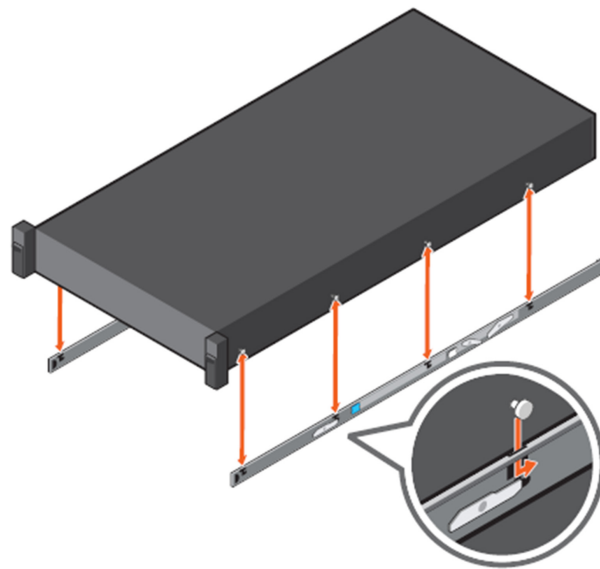

**Figure 48. Attach the inner rails to the system**

4. With the intermediate rails extended, install the system into the extended rails.

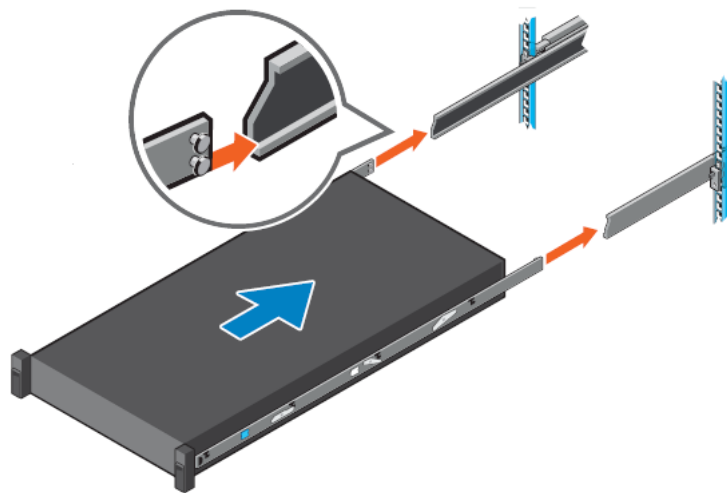

**Figure 49. Install system into the extended rails**

5. Pull blue slide release lock tabs forward or backward on both rails, and slide the system into the rack.

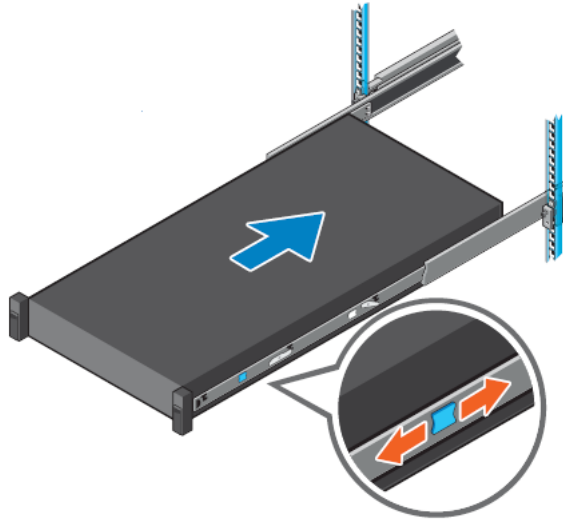

Figure 50. Slide system into the rack

# Operating Systems and Virtualization

## Topics:

- [Supported operating systems](#)

## Supported operating systems

The PowerEdge R7715 system supports the following operating systems:

- Microsoft Windows Server with Hyper-V
- Canonical Ubuntu Server LTS
- Red Hat Enterprise Linux
- SUSE Linux Enterprise Server
- VMware ESXi

For specifications and interoperability details, see [OS support](#).

# Dell Systems Management

Dell delivers management solutions that help IT administrators deploy, update, monitor, and manage IT assets. OpenManage solutions and tools enable you to solve and respond to problems quickly by manage Dell servers efficiently in physical and remote environments, and operating in-band and out-of-band (agent-free).

The OpenManage portfolio includes innovative embedded management tools such as the integrated Dell Remote Access Controller (iDRAC) and consoles like OpenManage Enterprise, OpenManage Power Manager Plugin, and tools like Repository Manager. Dell has developed comprehensive systems management solutions that are based on open standards by connecting and/or integrating it's offers with top system management vendors and frameworks such as Ansible, Microsoft, and VMware, enabling advanced management of Dell hardware. The key tools for managing Dell PowerEdge servers are iDRAC and OpenManage Enterprise (OME) console. OpenManage Enterprise helps the system administrators with the life cycle management of multiple generations of PowerEdge servers. OME has additional functions that can be added with plugins like OpenManage Enterprise Services, Update Manager, APEX AIOps Observability (formerly CloudIQ), and Power Manager. It also offers integration with VMware vCenter and Microsoft System Center, and a set of tools, including Repository Manager, enabling easy management of PowerEdge hardware. The four main pillars of Dell systems management closely align with the issues and business challenges that are faced by many IT departments.

- Automating IT management.
  - Comprehensive automation management for reducing OPEX and increasing uptime and overall efficiency of systems.
  - Comprehensive suite of tools to automate according to your needs.
- Management made simple.
  - Simple but powerful tools for managing your Dell servers.
  - Integrated tools that streamline support engagements.
  - Innovative at-the-box management features.
- Secure by default.
  - Dell servers offer robust security defenses to prevent the next generation of malicious attacks.
  - Security is designed deep into the hardware and firmware architecture for optimal protection.
- Smarter infrastructure management.
  - It offers a next-generation 1-to-many console to manage your IT and server infrastructure.
  - Embedded intelligence that is infrastructure-aware to optimize troubleshooting and deployment.

This document provides an overview of the OpenManage Systems Management offerings to help IT administrators choose the appropriate tools to completely manage Dell PowerEdge servers.

- The latest [Dell Systems Management Overview Guide](#).

## Topics:

- [Integrated Dell Remote Access Controller \(iDRAC\)](#)
- [Systems Management software support matrix](#)

## Integrated Dell Remote Access Controller (iDRAC)

iDRAC10 delivers advanced, agent-free, local and remote server administration. Embedded in every PowerEdge server, iDRAC10 provides a secure means to automate a multitude of common management tasks. iDRAC is embedded within every PowerEdge server and there is no additional software to install; just plug in the power and network cables, and iDRAC is ready to go. Even before installing an operating system (operating system) or hypervisor, IT administrators have a complete set of server management features at their fingertips.

With iDRAC10 in-place across the Dell PowerEdge portfolio, the same IT administration techniques and tools can be applied throughout. This consistent management platform allows scaling of PowerEdge servers as an organization's infrastructure grows. Customers can use the iDRAC RESTful API for the latest in scalable administration methods of PowerEdge servers. With this API, iDRAC enables support for the Redfish standard and enhances it with Dell extensions to optimize at-scale management of PowerEdge servers. By having iDRAC at the core, the entire OpenManage portfolio of Systems Management tools allows every customer to tailor an effective, affordable solution for any size environment.

Zero-Touch Provisioning (ZTP) is embedded in iDRAC. ZTP is an Intelligent Automation Dell's agent-free management. Once a PowerEdge server is connected to power and networking that system can be monitored and fully managed, whether you are standing in front of the server or remotely over a network. With no need for software agents, an IT administrator can:



- Monitor
- Manage
- Update
- Troubleshoot, and remediate Dell servers.

With features like zero-touch deployment and provisioning, and System Lockdown, iDRAC10 is purpose-built to simplify server administration. For those customers whose existing management platform uses in-band management, Dell does provide iDRAC Service Module, a lightweight service that can interact with both iDRAC10 and the host operating system to support legacy management platforms.

When ordered with DHCP enabled from the factory, PowerEdge servers can be automatically configured when they are initially powered up and connected to your network. This process uses profile-based configurations that ensure each server is configured per your specifications. This feature requires an iDRAC Enterprise license.

iDRAC10 offers the following license tiers:

**Table 39. iDRAC10 license tiers**

License	Description
iDRAC10 Core	<ul style="list-style-type: none"> <li>• Available for all servers.</li> <li>• Core system management features for users who are cost conscious.</li> </ul>
iDRAC10 Enterprise	<ul style="list-style-type: none"> <li>• Available as an upsell on all servers.</li> <li>• Includes all features of Core. Also, includes additional automation features and virtual console and security features.</li> <li>• Bundled with Secure Enterprise Key Management (SEKM) and Secure Component Verification (SCV) licenses.</li> </ul> <p> <b>NOTE:</b> Available in March 2025</p>
iDRAC10 Datacenter	<ul style="list-style-type: none"> <li>• Available as an upsell on all servers.</li> <li>• Includes all features of Core and Enterprise.</li> <li>• Includes key features such as telemetry streaming and thermal management.</li> <li>• Includes advanced accelerators (GPU and DPU) system management and advanced air and liquid cooling.</li> </ul> <p> <b>NOTE:</b> Available in June 2025</p>

For a full list of iDRAC features by license tier, see the **Integrated Dell Remote Access Controller 10 User's Guide** at [Dell.com](https://www.dell.com).

For more details on iDRAC10 including white papers and videos, see:

- Support for Integrated Dell Remote Access Controller 10 (iDRAC10) on the [Knowledge Base](#) page at [Dell.com](https://www.dell.com)

## Systems Management software support matrix

**Table 40. Systems Management software support matrix**

Categories	Features	PE mainstream
Embedded Management	iDRAC	Supported
	iDRAC Direct	Supported
	iDRAC RESTful API with Redfish	Supported
	Racadm CLI	Supported
	iDRAC Service Module (iSM)	Supported
Change Management	Dell Repository Manager	Supported

**Table 40. Systems Management software support matrix (continued)**

<b>Categories</b>	<b>Features</b>	<b>PE mainstream</b>
	Dell System Update	Supported
	Enterprise Catalogs	Supported
	Server Update Utility (SUU)	Supported
OpenManage console	OpenManage Enterprise (OME)	Supported
	OME Power Manager	Supported
	OME Services	Supported
	OME Update Manager	Supported
	OME APEX AIOps Observability	Supported
	OME Integration for VMware vCenter (with VMware Aria Operations)	Supported
	OME integration for Microsoft System Center	Supported
	OpenManage Integration for Windows Admin Center	Supported
Mobility	OME Mobile with Quick Sync 2 wireless module	Supported
Tools	IPMI	Supported
OpenManage Integrations	Red Hat Ansible Collections	Supported
	Terraform Providers	Supported
Security	Cryptographically signed firmware	Supported
	Data at Rest Encryption (SEDs with local or external key mgmt)	Supported
	Secure Boot	Supported
	Secured Component Verification (Hardware integrity check)	Supported
	Secure Erase	Supported
	Silicon Root of Trust	Supported
	System Lockdown	Supported
	TPM 2.0 FIPS, CC-TCG certified	Supported
	Chassis Intrusion Detection	Supported
	AMD Secure Memory Encryption (SME)	Supported
	AMD Secure Encrypted Virtualization (SEV)	Supported
Operating system	Canonical Ubuntu Server LTS	Supported
	Microsoft Windows Server with Hyper-V	Supported
	Red Hat Enterprise Linux	Supported
	SUSE Linux Enterprise Server	Supported
	VMware ESXi	Supported

## Appendix A: Additional specifications

### Topics:

- Chassis dimensions
- System weight
- NIC port specifications
- DPU Specifications
- Video specifications
- USB Ports
- PSU rating
- Environmental specifications

### Chassis dimensions

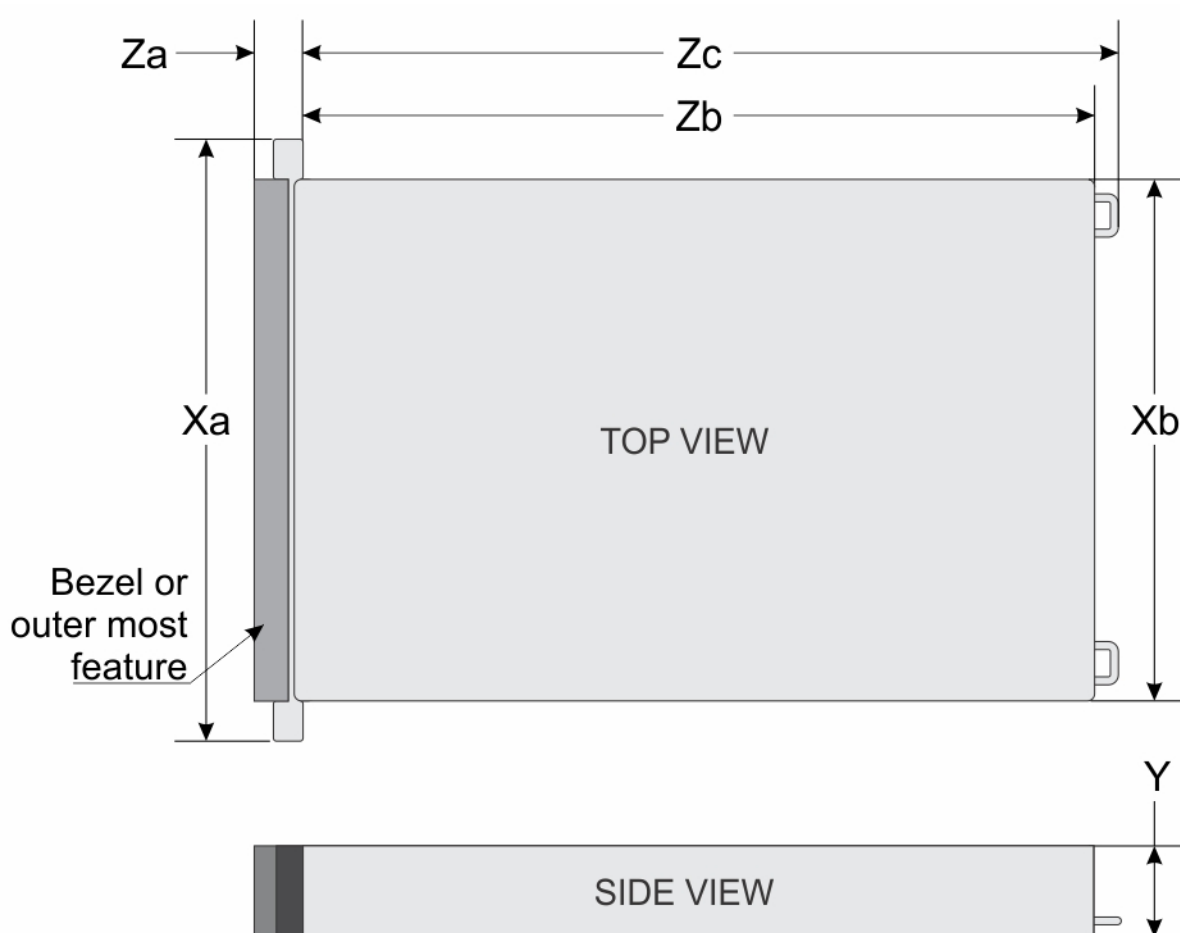

Figure 51. Chassis dimensions

**Table 41. PowerEdge R7715 chassis dimensions**

Drives	Xa	Xb	Y	Za	Zb	Zc
All drive configurations	482.0 mm (18.97 inches)	434.0 mm (17.08 inches)	86.8 mm (3.41 inches)	30.78 mm (1.21 inches) With bezel 29.89mm (1.18 inches) Without bezel	700.7 mm (27.58 inches) Ear to rear wall	771.62 mm (30.38 inches) Ear to PSU handle

**NOTE:** Zb is the nominal rear wall external surface where the HPM board I/O connectors reside.

## System weight

**Table 42. PowerEdge R7715 system weight**

System configuration	Maximum weight (with all drives/SSDs)
No backplane configuration	22.93 kg (50.55 pounds)
2 x U.2 SSD	20.24 kg (44.62 pounds)
8 x 2.5-inch Universal drives	26.26 kg (57.89 pounds)
8 x EDSFF E3.S Gen5 NVMe drives	27.33 kg (60.25 pounds)
12 x 3.5-inch SAS/SATA drives	26.85 kg (59.19 pounds)
16 x 2.5-inch SAS/SATA + 8 x U.2 drives	26.58 kg (58.59 pounds)
16 x 2.5-inch SAS/SATA drives	26.81 kg (59.10 pounds)
16 x EDSFF E3.S Gen5 NVMe drives	28.68 kg (63.22 pounds)
24 x 2.5-inch SAS/SATA drives	27.67 kg (61.00 pounds)
32 x EDSFF E3.S Gen5 NVMe drives	26.68 kg (58.81 pounds)
40 x EDSFF E3.S Gen5 NVMe drives	28.38 kg (62.56 pounds)

**Table 43. PowerEdge R7715 weight handling recommendations**

Chassis weight	Description
40–70 pounds	Recommend two people to lift.
70–120 pounds	Recommend three people to lift.
≥ 121 pounds	Recommend to use a server-lift.

## NIC port specifications

The PowerEdge R7715 system supports one 10/100/1000 Mbps BMC Ethernet, up to eight PCIe Add-in cards, up to two fibre channel HBA cards, and two optional Open Compute Project (OCP) cards.

**Table 44. NIC port specification for the system**

Feature	Specifications
Datacenter-Secure Control Module (DC-SCM)	1 Gb Dedicated BMC Ethernet port x1
OCP NIC 3.0 card	200GbE x 2 (configurable to 400GbE x1), 100 GbE x 2, 25 GbE x 2, 25 GbE x 4 , 10 GbE x 4, 10 GbE x 2, 1 GbE x 4
PCIe Add-in Card (AIC) NIC	400 GbE x 1, 100 GbE x 2

**Table 44. NIC port specification for the system (continued)**

Feature	Specifications
Fibre channel HBA	FC32, FC64

## DPU Specifications

The PowerEdge R7715 platform accommodates Data Processing Units (DPUs). These units are system-on-chip solutions that combine ARM cores, high-performance NICs, and programmable acceleration engines to offload and accelerate data center infrastructure services.

**Table 45. Supported Data Processing Units(DPU) Cards**

Feature	NVIDIA BlueField-3 2x200 GbE B3220	NVIDIA BlueField-3 1x400 GbE B3140H *
Type	Data Processing Units (DPU)	Data Processing Units (DPU)
Networking	2 x 200 GbE	1x400 GbE
Form Factor	FHHL	FHHL
Interface	PCIe Gen5 x16	PCIe Gen5 x16
Power Consumption	150 W	75 W
Compatible Risers	RC 1(Slot 7), RC 2(Slot 7), RC 3(Slots 2,7), RC 4(Slots 2,7), RC 5(Slots 2,7), RC 8(Slots 2,7)	TBD

**NOTE:** This document provides a comprehensive list of product features. However, features marked with an asterisk (\*) may not be available at launch but introduced in future updates. Please note that this document does not confirm the availability or release timeline of any feature. For the most accurate and up-to-date information on feature availability, please refer to the product configurator page on dell.com.

**NOTE:** \* Feature not available at product launch in November,2025. Please refer to the product configurator page on Dell.com to confirm feature availability.

## Video specifications

The PowerEdge R7715 system supports integrated Matrox G200 graphics controller with 16 MB of video frame buffer.

**Table 46. Supported video resolution options**

Resolution	Refresh rate (Hz)	Color depth (bits)
640 x 480	60	8, 16, 32
800 x 600	60	8, 16, 32
1024 x 768	60	8, 16, 32
1152 x 864	60	8, 16, 32
1280 x 800	60	8, 16, 32
1280 x 1024	60	8, 16, 32
1360 x 768	60	8, 16, 32
1400 x 1050	60	8, 16, 32
1440 x 900	60	8, 16, 32
1600 x 1200	60	8, 16, 32

**Table 46. Supported video resolution options (continued)**

Resolution	Refresh rate (Hz)	Color depth (bits)
1680 x 1050	60	8, 16, 32
1920 x 1080	60	8, 16, 32
1920 x 1200	60	8, 16, 32

## USB Ports



**Figure 52. Front USB Port**

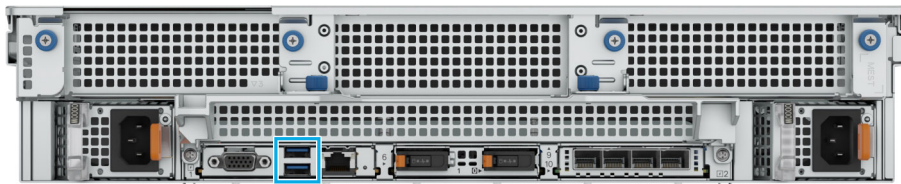

**Figure 53. Rear USB Port**

**Table 47. Systems USB Specifications**

Front		Rear	
USB port type	No. of ports	USB port type	No. of ports
USB 2.0 Type-A (optional LCP KVM)	1	USB 3.1 Type-A	1
USB 2.0 Type-C (HOST/BMC Direct)	1	USB 3.1 Type-A	1

## PSU rating

Below table lists the power capacity of the PSUs in high/low line operation mode.

**Table 48. PSU highline and lowline rating**

PSU	Class	Output power while used at					
		AC			HVDC	DC	
		High Line 200-240V	Low Line 100-120 V	277V	336V	240V	-48V
3200 W 277 Vac and HVDC	Titanium	N/A	N/A	3200 W	N/A	N/A	N/A
	Titanium	N/A	N/A	N/A	3200 W	N/A	N/A

**Table 48. PSU highline and lowline rating (continued)**

PSU	Class	Output power while used at					
		AC			HVDC	DC	
		High Line 200-240V	Low Line 100-120 V	277V	336V	240V	-48V
3200 W Titanium	Titanium	2900 W @ 200-240 V  3200 W @ 220.1-240 V	N/A	N/A	N/A	N/A	N/A
	N/A	N/A	N/A	N/A	N/A	3200 W	N/A
2400 W Titanium	Titanium	2400 W	1400 W	N/A	N/A	N/A	N/A
	Titanium	N/A	N/A	N/A	N/A	2400 W	N/A
1800 W Titanium *	Titanium	1800W	N/A	N/A	N/A	N/A	N/A
	N/A	N/A	N/A	N/A	N/A	1800W	N/A
1500 W 277 Vac and HVDC	Titanium	N/A	N/A	1500 W	N/A	N/A	N/A
	Titanium	N/A	N/A	N/A	1500W	N/A	N/A
1500 W Titanium	Titanium	1500W	1050W	N/A	N/A	N/A	N/A
	N/A	N/A	N/A	N/A	N/A	1500W	N/A
1400 W -48Vdc	N/A	N/A	N/A	N/A	N/A	N/A	1400W
1100 W Titanium	Titanium	1100W	1050W	N/A	N/A	N/A	N/A
	N/A	N/A	N/A	N/A	N/A	1100W	N/A
1100 W Platinum	Platinum	1100W	1050W	N/A	N/A	N/A	N/A
	Platinum	N/A	N/A	N/A	N/A	1100W	N/A
800 W Titanium	Titanium	800W	800W	N/A	N/A	N/A	N/A
	N/A	N/A	N/A	N/A	N/A	800W	N/A
800 W Platinum	Platinum	800W	800W	N/A	N/A	N/A	N/A
	N/A	N/A	N/A	N/A	N/A	800W	N/A

**NOTE:** This document provides a comprehensive list of product features. However, features marked with an asterisk (\*) may not be available at launch but introduced in future updates. Please note that this document does not confirm the availability or release timeline of any feature. For the most accurate and up-to-date information on feature availability, please refer to the product configurator page on dell.com.

**NOTE:** \* Feature not available at product launch in November,2025. Please refer to the product configurator page on Dell.com to confirm feature availability.

The PowerEdge R7715 supports up to two AC power supplies with 1+1 redundancy, autosensing, and auto switching capability.

If two PSUs are present during POST, a comparison is made between the wattage capacities of the PSUs. In case the PSU wattages do not match, the larger of the two PSUs is enabled. Also, there is a PSU mismatch warning that is displayed in the BIOS or iDRAC.

If a second PSU is added at run-time, in order for that particular PSU to be enabled, the wattage capacity of the first PSU must equal the second PSU. Otherwise, the PSU is identified as unmatched in iDRAC and the second PSU is not enabled.

Dell PSUs have achieved Platinum efficiency levels as shown in the table below.

**Table 49. PSU efficiency level**

Efficiency Targets by Load						
Form factor	Output	Class	10%	20%	50%	100%
Redundant 73.5 mm	3200 W 277Vac and HVDC	Titanium	90.00%	94.00%	96.00%	91.00%
Redundant 73.5 mm	3200 W mixed mode	Titanium	90.00%	94.00%	96.00%	91.00%
Redundant 60 mm	2400 W mixed mode	Titanium	90.00%	94.00%	96.00%	91.00%
Redundant 60 mm	1800 W mixed mode*	Titanium	90.00%	94.00%	96.00%	91.00%
Redundant 60 mm	1500 W mixed mode	Titanium	90.00%	94.00%	96.00%	91.00%
Redundant 60 mm	1500 W 277Vac and HVDC	Titanium	90.00%	94.00%	96.00%	91.00%
Redundant 60	1400 W HVDC	N/A	85.00%	90.00%	94.00%	92.00%
Redundant 60 mm	1100 W mixed mode	Titanium	90.00%	94.00%	96.00%	91.00%
Redundant 60 mm	1100 W mixed mode	Platinum	N/A	90.00%	94.00%	91.00%
Redundant 60 mm	800 W mixed mode	Titanium	90.00%	94.00%	96.00%	91.00%
Redundant 60 mm	800 W mixed mode	Platinum	N/A	90.00%	94.00%	91.00%

**NOTE:** This document provides a comprehensive list of product features. However, features marked with an asterisk (\*) may not be available at launch but introduced in future updates. Please note that this document does not confirm the availability or release timeline of any feature. For the most accurate and up-to-date information on feature availability, please refer to the product configurator page on dell.com.

**NOTE:** \*Feature not available at product launch in November,2025. Please refer to the product configurator page on Dell.com to confirm feature availability.

## Environmental specifications

**NOTE:** For additional information about environmental certifications, refer to the **Product Environmental Datasheet** located with the **Manuals & Documents** on [Dell Support](#).

**Table 50. Continuous Operation Specifications for ASHRAE A2**

Temperature	Specifications
<b>Allowable continuous operations</b>	
Temperature range for altitudes <= 900 m (<= 2953 ft)	10–35°C (50–95°F) with no direct sunlight on the equipment
Humidity percent range (non-condensing at all times)	8% RH with -12°C minimum dew point to 80% RH with 21°C (69.8°F) maximum dew point
Operational altitude de-rating	Maximum temperature is reduced by 1°C/300 m (1.8°F/984 Ft) above 900 m (2953 Ft)

**Table 51. Continuous Operation Specifications for ASHRAE A3**

Temperature	Specifications
<b>Allowable continuous operations</b>	
Temperature range for altitudes <= 900 m (<= 2953 ft)	5–40°C (41–104°F) with no direct sunlight on the equipment
Humidity percent range (non-condensing at all times)	8% RH with -12°C minimum dew point to 85% RH with 24°C (75.2°F) maximum dew point

**Table 51. Continuous Operation Specifications for ASHRAE A3 (continued)**

Temperature	Specifications
<b>Allowable continuous operations</b>	
Operational altitude de-rating	Maximum temperature is reduced by 1°C/175 m (1.8°F/574 Ft) above 900 m (2953 Ft)

**Table 52. Continuous Operation Specifications for ASHRAE A4**

Temperature	Specifications
<b>Allowable continuous operations</b>	
Temperature range for altitudes <= 900 m (<= 2953 ft)	5–45°C (41–113°F) with no direct sunlight on the equipment
Humidity percent range (non-condensing at all times)	8% RH with -12°C minimum dew point to 90% RH with 24°C (75.2°F) maximum dew point
Operational altitude de-rating	Maximum temperature is reduced by 1°C/125 m (1.8°F/410 Ft) above 900 m (2953 Ft)

**Table 53. Continuous Operation Specifications for Rugged Environment**

Temperature	Specifications
<b>Allowable continuous operations</b>	
Temperature range for altitudes <= 900 m (<= 2953 ft)	5–55°C (41–131°F) with no direct sunlight on the equipment
Humidity percent range (non-condensing at all times)	8% RH with -12°C minimum dew point to 90% RH with 24°C (75.2°F) maximum dew point
Operational altitude de-rating	Maximum temperature is reduced by 1°C/125 m (1.8°F/410 Ft) above 900 m (2953 Ft)

**Table 54. Common Environmental Specifications for ASHRAE A2, A3, A4 and Rugged**

Temperature	Specifications
<b>Allowable continuous operations</b>	
Maximum temperature gradient (applies to both operation and non-operation)	20°C in an hour* (36°F in an hour) and 5°C in 15 minutes (9°F in 15 minutes), 5°C in an hour* (9°F in an hour) for tape <i>i</i> <b>NOTE:</b> * - Per ASHRAE thermal guidelines for tape hardware, these are not instantaneous rates of temperature change.
Non-operational temperature limits	<ul style="list-style-type: none"> <li>-40°C to 65°C (-40°F to 149°F) applicable for air cooling configuration</li> <li>-40°C to -5°C (-40°F to 23°F**) applicable for DLC configuration</li> </ul> <i>i</i> <b>NOTE:</b> ** Liquid filled components, or systems/solutions containing liquid filled components are limited to approximately 5°C above their freeze point. At this time the only authorized liquid coolant is Recohem PG25 with a freeze point between -9°C and -13°C, therefore the lower non-operational temperature limit is -5°C. Components and systems/solutions that can contain liquid but do not at the time of testing shall be tested to the -40°C lower non-operational temperature limit.
Non-operational humidity limits	5% to 95% RH with 27°C (80.6°F) maximum dew point
Maximum non-operational altitude	12,000 meters (39,370 feet)
Maximum operational altitude	3,048 meters (10,000 feet)

**Table 55. Maximum vibration specifications**

Maximum vibration	Specifications
Operating	0.21 G <sub>rms</sub> at 5 Hz to 500 Hz (all operation orientations)
Storage	1.38 G <sub>rms</sub> at 7 Hz to 250 Hz for 15 minutes (all six sides tested)

**Table 56. Maximum shock pulse specifications**

Maximum shock pulse	Specifications
Operating	Six consecutively executed shock pulses in the positive and negative x, y, and z axis of 6 G for up to 11 ms.
Storage	Six consecutively executed shock pulses in the positive and negative x, y, and z axis (one pulse on each side of the system) of 71 G for up to 2 ms.

## Thermal restriction matrix

**Table 57. Label reference**

Label	Description
STD	Standard
HPR (Silver)	High performance Silver (HPR SLVR) fan
HPR (Gold)	High performance Gold (HPR GOLD) fan
HSK	Heat sink
LP	Low profile
FH	Full height
DLC	Direct Liquid Cooling

**Table 58. Processor and heat sink matrix**

Heat sink	Processor TDP
2U-Ext	Regular cooling

**NOTE:** The configuration's ambient temperature is dictated by its critical component. For example, if the processor's ambient temperature is 35°C, the DIMM is 35°C, and the GPU is 30°C, the configuration's ambient temperature can only be 30°C.

**Table 59. CPU thermal restriction matrix for Air cooling Non-GPU configuration**

CPU thermal restriction matrix for Air cooling Non-GPU configuration											
2U-Ext HSK ; Silver Fan ; HPR Gold Fan , HPR P Fan											
CPU	cTDP	Max cTDP	Core Count	24 x 2.5-inch	16 x 2.5-inch	16 x EDSFF E3.S NVMe	32 x EDSFF E3.S NVMe	No Backplane / 2 x U.2	16 x EDSFF E3.S NVMe		
				Regular Air shroud							
				Supported at 35°C							
9015	125	155	8	2U-Ext HSK	2U-Ext HSK	2U-Ext HSK	2U-Ext HSK	2U-Ext HSK	2U-Ext HSK		
				Silver Fan	Silver Fan	Silver Fan	Silver Fan	Silver Fan	Silver Fan		
9115	125	155	16	2U-Ext HSK	2U-Ext HSK	2U-Ext HSK	2U-Ext HSK	2U-Ext HSK	2U-Ext HSK		

**Table 59. CPU thermal restriction matrix for Air cooling Non-GPU configuration (continued)**

<b>CPU thermal restriction matrix for Air cooling Non-GPU configuration</b>												
<b>2U-Ext HSK ; Silver Fan ; HPR Gold Fan , HPR P Fan</b>												
<b>CPU</b>	<b>cTDP</b>	<b>Max cTDP</b>	<b>Core Count</b>	<b>24 x 2.5-inch</b>	<b>16 x 2.5-inch</b>	<b>16 x EDSFF E3.S NVMe</b>	<b>32 x EDSFF E3.S NVMe</b>	<b>No Backplane / 2 x U.2</b>	<b>16 x EDSFF E3.S NVMe</b>			
				<b>Regular Air shroud</b>								
				<b>Supported at 35°C</b>								
				Silver Fan	Silver Fan	Silver Fan	Silver Fan	Silver Fan	Silver Fan			
9135	200	240	16	2U-Ext HSK Silver Fan	2U-Ext HSK Silver Fan	2U-Ext HSK Silver Fan	2U-Ext HSK Silver Fan	2U-Ext HSK Silver Fan	2U-Ext HSK Silver Fan			
9255	200	240	24	2U-Ext HSK Silver Fan	2U-Ext HSK Silver Fan	2U-Ext HSK Silver Fan	2U-Ext HSK Silver Fan	2U-Ext HSK Silver Fan	2U-Ext HSK Silver Fan			
9335	280	300	32	2U-Ext HSK Silver Fan	2U-Ext HSK Silver Fan	2U-Ext HSK Silver Fan	2U-Ext HSK Silver Fan	2U-Ext HSK Silver Fan	2U-Ext HSK Silver Fan			
9355P	280	300	32	2U-Ext HSK Silver Fan	2U-Ext HSK Silver Fan	2U-Ext HSK Silver Fan	2U-Ext HSK Silver Fan	2U-Ext HSK Silver Fan	2U-Ext HSK Silver Fan			
9455	300	300	48	2U-Ext HSK Silver Fan	2U-Ext HSK Silver Fan	2U-Ext HSK Silver Fan	2U-Ext HSK Silver Fan	2U-Ext HSK Silver Fan	2U-Ext HSK Silver Fan			
9535	300	300	65	2U-Ext HSK Silver Fan	2U-Ext HSK Silver Fan	2U-Ext HSK Silver Fan	2U-Ext HSK Silver Fan	2U-Ext HSK Silver Fan	2U-Ext HSK Silver Fan			
9175F	320	400	16	2U-Ext HSK HPR Gold Fan	2U-Ext HSK HPR Gold Fan	2U-Ext HSK HPR Gold Fan	2U-Ext HSK HPR Gold Fan	2U-Ext HSK HPR Gold Fan	2U-Ext HSK HPR Gold Fan			
9275F	320	400	24	2U-Ext HSK HPR Gold Fan	2U-Ext HSK HPR Gold Fan	2U-Ext HSK HPR Gold Fan	2U-Ext HSK HPR Gold Fan	2U-Ext HSK HPR Gold Fan	2U-Ext HSK HPR Gold Fan			
9375F	320	400	32	2U-Ext HSK HPR Gold Fan	2U-Ext HSK HPR Gold Fan	2U-Ext HSK HPR Gold Fan	2U-Ext HSK HPR Gold Fan	2U-Ext HSK HPR Gold Fan	2U-Ext HSK HPR Gold Fan			
9475F	400	400	48	2U-Ext HSK HPR Gold Fan	2U-Ext HSK HPR Gold Fan	2U-Ext HSK HPR Gold Fan	2U-Ext HSK HPR Gold Fan	2U-Ext HSK HPR Gold Fan	2U-Ext HSK HPR Gold Fan			

**Table 59. CPU thermal restriction matrix for Air cooling Non-GPU configuration (continued)**

<b>CPU thermal restriction matrix for Air cooling Non-GPU configuration</b>											
<b>2U-Ext HSK ; Silver Fan ; HPR Gold Fan , HPR P Fan</b>											
CPU	cTDP	Max cTDP	Core Count	24 x 2.5-inch	16 x 2.5-inch	16 x EDSFF E3.S NVMe	32 x EDSFF E3.S NVMe	No Backplane/ 2 x U.2	16 x EDSFF E3.S NVMe		
				<b>Regular Air shroud</b>							
				<b>Supported at 35°C</b>							
9555P	360	400	64	2U-Ext HSK HPR Gold Fan	2U-Ext HSK HPR Gold Fan	2U-Ext HSK HPR Gold Fan	2U-Ext HSK HPR Gold Fan	2U-Ext HSK HPR Gold Fan	2U-Ext HSK HPR Gold Fan		
9575F	400	400	64	2U-Ext HSK HPR Gold Fan	2U-Ext HSK HPR Gold Fan	2U-Ext HSK HPR Gold Fan	2U-Ext HSK HPR Gold Fan	2U-Ext HSK HPR Gold Fan	2U-Ext HSK HPR Gold Fan		
9655P	320	400	96	2U-Ext HSK HPR Gold Fan	2U-Ext HSK HPR Gold Fan	2U-Ext HSK HPR Gold Fan	2U-Ext HSK HPR Gold Fan	2U-Ext HSK HPR Gold Fan	2U-Ext HSK HPR Gold Fan		
9745	400	400	128	2U-Ext HSK HPR Gold Fan	2U-Ext HSK HPR Gold Fan	2U-Ext HSK HPR Gold Fan	2U-Ext HSK HPR Gold Fan	2U-Ext HSK HPR Gold Fan	2U-Ext HSK HPR Gold Fan		
9825	390	400	144	2U-Ext HSK HPR Gold Fan	2U-Ext HSK HPR Gold Fan	2U-Ext HSK HPR Gold Fan	2U-Ext HSK HPR Gold Fan	2U-Ext HSK HPR Gold Fan	2U-Ext HSK HPR Gold Fan		
9845	390	400	160	2U-Ext HSK HPR Gold Fan	2U-Ext HSK HPR Gold Fan	2U-Ext HSK HPR Gold Fan	2U-Ext HSK HPR Gold Fan	2U-Ext HSK HPR Gold Fan	2U-Ext HSK HPR Gold Fan		



**Table 60. Memory thermal restriction matrix for Air Cooling Non-GPU configuration**

<b>Memory thermal restriction matrix for Air Cooling Non-GPU configuration</b>						
<b>2U-Ext 2U-Ext HSK ; HPR Gold Fan , HPR P Fan</b>						
memory	24 x 2.5-inch	16 x 2.5-inch	16 x EDSFF E3.S NVMe	32 x EDSFF E3.S NVMe	No Backplane/ 2 x U.2	16 x EDSFF E3.S NVMe
	<b>Regular Air shroud</b>					
	<b>Supported at 35°C</b>					
16 GB RDIMM	Silver Fan	Silver Fan	Silver Fan	Silver Fan	Silver Fan	Silver Fan
32 GB RDIMM	Silver Fan	Silver Fan	Silver Fan	Silver Fan	Silver Fan	Silver Fan
64 GB RDIMM	Silver Fan	Silver Fan	Silver Fan	Silver Fan	Silver Fan	Silver Fan
96 GB RDIMM	HPR Gold Fan	HPR Gold Fan	HPR Gold Fan	HPR Gold Fan	HPR Gold Fan	HPR Gold Fan
128 GB RDIMM	HPR Gold Fan	HPR Gold Fan	HPR Gold Fan	HPR Gold Fan	HPR Gold Fan	HPR Gold Fan

**Table 60. Memory thermal restriction matrix for Air Cooling Non-GPU configuration (continued)**

Memory thermal restriction matrix for Air Cooling Non-GPU configuration						
2U-Ext 2U-Ext HSK ; HPR Gold Fan , HPR P Fan						
memory	24 x 2.5-inch	16 x 2.5-inch	16 x EDSFF E3.S NVMe	32 x EDSFF E3.S NVMe	No Backplane/ 2 x U.2	16 x EDSFF E3.S NVMe
	Regular Air shroud					
	Supported at 35°C					
256 GB RDIMM	TBD	TBD	TBD	TBD	TBD	TBD

**Table 61. GPU thermal restriction matrix for Air Cooling Non-GPU configuration**

GPU thermal restriction matrix for Air Cooling Non-GPU configuration						
2U-Ext HSK ; Silver Fan ; HPR Gold Fan , HPR P Fan						
GPU	24 x 2.5-inch	16 x 2.5-inch	16 x EDSFF E3.S NVMe	32 x EDSFF E3.S NVMe	No Backplane/ 2 x U.2	16 x EDSFF E3.S NVMe
	Regular Air shroud					
	 <b>NOTE:</b> ** Components that support max 30°C.					
	 <b>NOTE:</b> Components without ** support max 35°C.					
L4 24 GB	HPR Gold Fan**	HPR Gold Fan	HPR Gold Fan	HPR Gold Fan	HPR Gold Fan	HPR Gold Fan

**Table 62. CPU thermal restriction matrix for Air cooling GPU configuration**

CPU thermal restriction matrix for Air cooling GPU configuration						
1U GPU HSK , HPR P Fan						
CPU	cTDP	Max cTDP	Core Count	16 x 2.5-inch	8 x 2.5-inch	8 x EDSFF E3.S NVMe
				GPU Air shroud		
				Supported at 35°C		
9015	125	155	8	1U GPU HSK HPR P Fan	1U GPU HSK HPR P Fan	1U GPU HSK HPR P Fan
9115	125	155	16	1U GPU HSK HPR P Fan	1U GPU HSK HPR P Fan	1U GPU HSK HPR P Fan
9135	200	240	16	1U GPU HSK HPR P Fan	1U GPU HSK HPR P Fan	1U GPU HSK HPR P Fan
9255	200	240	24	1U GPU HSK HPR P Fan	1U GPU HSK HPR P Fan	1U GPU HSK HPR P Fan
9335	280	300	32	1U GPU HSK HPR P Fan	1U GPU HSK HPR P Fan	1U GPU HSK HPR P Fan
9355P	280	300	32	1U GPU HSK HPR P Fan	1U GPU HSK HPR P Fan	1U GPU HSK HPR P Fan
9455	300	300	48	1U GPU HSK HPR P Fan	1U GPU HSK HPR P Fan	1U GPU HSK HPR P Fan

**Table 62. CPU thermal restriction matrix for Air cooling GPU configuration (continued)**

CPU thermal restriction matrix for Air cooling GPU configuration						
1U GPU HSK , HPR P Fan						
CPU	cTDP	Max cTDP	Core Count	16 x 2.5-inch	8 x 2.5-inch	8 x EDSFF E3.S NVMe
				GPU Air shroud		
				Supported at 35°C		
9535	300	300	64	1U GPU HSK HPR P Fan	1U GPU HSK HPR P Fan	1U GPU HSK HPR P Fan
9175F	320	400	16	1U GPU HSK HPR P Fan	1U GPU HSK HPR P Fan	1U GPU HSK HPR P Fan
9275F	320	400	24	Not Support	Not Support	Not Support
9375F	320	400	32	1U GPU HSK HPR P Fan	1U GPU HSK HPR P Fan	1U GPU HSK HPR P Fan
9475F	400	400	48	1U GPU HSK HPR P Fan	1U GPU HSK HPR P Fan	1U GPU HSK HPR P Fan
9555P	360	400	64	1U GPU HSK HPR P Fan	1U GPU HSK HPR P Fan	1U GPU HSK HPR P Fan
9575F	400	400	64	1U GPU HSK HPR P Fan	1U GPU HSK HPR P Fan	1U GPU HSK HPR P Fan
9655P	320	400	96	1U GPU HSK HPR P Fan	1U GPU HSK HPR P Fan	1U GPU HSK HPR P Fan
9745	400	400	128	1U GPU HSK HPR P Fan	1U GPU HSK HPR P Fan	1U GPU HSK HPR P Fan
9825	390	400	144	1U GPU HSK HPR P Fan	1U GPU HSK HPR P Fan	1U GPU HSK HPR P Fan
9845	390	400	160	1U GPU HSK HPR P Fan	1U GPU HSK HPR P Fan	1U GPU HSK HPR P Fan

**Table 63. Memory thermal restriction matrix for Air Cooling GPU configuration**

Memory thermal restriction matrix for Air Cooling GPU configuration			
2U-Ext HSK ; Silver Fan ; HPR Gold Fan , HPR P Fan			
memory	16 x 2.5-inch	8 x 2.5-inch	8 x EDSFF E3.S NVMe
	Regular Air shroud		
	Supported at 35°C		
16 GB RDIMM	HPR P Fan	HPR P Fan	HPR P Fan
32 GB RDIMM	HPR P Fan	HPR P Fan	HPR P Fan
64 GB RDIMM	HPR P Fan	HPR P Fan	HPR P Fan

**Table 63. Memory thermal restriction matrix for Air Cooling GPU configuration (continued)**

Memory thermal restriction matrix for Air Cooling GPU configuration			
2U-Ext HSK ; Silver Fan ; HPR Gold Fan , HPR P Fan			
memory	16 x 2.5-inch	8 x 2.5-inch	8 x EDSFF E3.S NVMe
	Regular Air shroud		
	Supported at 35°C		
96 GB RDIMM	HPR P Fan	HPR P Fan	HPR P Fan
128 GB RDIMM	HPR P Fan	HPR P Fan	HPR P Fan
256 GB RDIMM	TBD	TBD	TBD

**Table 64. CPU thermal restriction matrix for Direct Liquid Cooling Non-GPU configuration**

CPU thermal restriction matrix for Direct Liquid Cooling Non-GPU configuration							
DLC Module ; Silver Fan ; HPR Gold Fan							
CPU	cTDP	Max cTDP	Core Count	24 x U.2	8 x 2.5-inch	16 x 2.5-inch	8 x EDSFF E3.S NVMe
				Regular Air shroud			
				NOTE: Components support max 35°C.			
9015	125	155	8	DLC Module Silver Fan	DLC Module Silver Fan	DLC Module Silver Fan	DLC Module Silver Fan
9115	125	155	16	DLC Module Silver Fan	DLC Module Silver Fan	DLC Module Silver Fan	DLC Module Silver Fan
9135	200	240	16	DLC Module Silver Fan	DLC Module Silver Fan	DLC Module Silver Fan	DLC Module Silver Fan
9255	200	240	24	DLC Module Silver Fan	DLC Module Silver Fan	DLC Module Silver Fan	DLC Module Silver Fan
9335	280	300	32	DLC Module Silver Fan	DLC Module Silver Fan	DLC Module Silver Fan	DLC Module Silver Fan
9355P	280	300	32	DLC Module Silver Fan	DLC Module Silver Fan	DLC Module Silver Fan	DLC Module Silver Fan
9455	300	300	48	DLC Module Silver Fan	DLC Module Silver Fan	DLC Module Silver Fan	DLC Module Silver Fan
9535	300	300	64	DLC Module Silver Fan	DLC Module Silver Fan	DLC Module Silver Fan	DLC Module Silver Fan
9175F	320	400	16	DLC Module Silver Fan	DLC Module Silver Fan	DLC Module Silver Fan	DLC Module Silver Fan
9275F	320	400	24	DLC Module Silver Fan	DLC Module Silver Fan	DLC Module Silver Fan	DLC Module Silver Fan
9375F	320	400	32	DLC Module	DLC Module	DLC Module	DLC Module

**Table 64. CPU thermal restriction matrix for Direct Liquid Cooling Non-GPU configuration (continued)**

CPU thermal restriction matrix for Direct Liquid Cooling Non-GPU configuration							
DLC Module ; Silver Fan ; HPR Gold Fan							
CPU	cTDP	Max cTDP	Core Count	24 x U.2	8 x 2.5-inch	16 x 2.5-inch	8 x EDSFF E3.S NVMe
				Regular Air shroud			
				i   NOTE: Components support max 35°C.			
				Silver Fan	Silver Fan	Silver Fan	Silver Fan
9475F	400	400	48	DLC Module Silver Fan	DLC Module Silver Fan	DLC Module Silver Fan	DLC Module Silver Fan
9555P	360	400	64	DLC Module Silver Fan	DLC Module Silver Fan	DLC Module Silver Fan	DLC Module Silver Fan
9575F	400	400	64	DLC Module Silver Fan	DLC Module Silver Fan	DLC Module Silver Fan	DLC Module Silver Fan
9655P	320	400	96	DLC Module Silver Fan	DLC Module Silver Fan	DLC Module Silver Fan	DLC Module Silver Fan
9745	400	400	128	DLC Module Silver Fan	DLC Module Silver Fan	DLC Module Silver Fan	DLC Module Silver Fan
9825	390	400	144	DLC Module Silver Fan	DLC Module Silver Fan	DLC Module Silver Fan	DLC Module Silver Fan
9845	390	400	160	DLC Module Silver Fan	DLC Module Silver Fan	DLC Module Silver Fan	DLC Module Silver Fan

**Table 65. Memory thermal restriction matrix for Direct Liquid Cooling Non-GPU configuration**

Memory thermal restriction matrix for Direct Liquid Cooling Non-GPU configuration				
DLC Module ; Silver Fan , HPR Gold Fan				
Memory	24 x U.2	8 x 2.5-inch	16 x 2.5-inch	8 x EDSFF E3.S NVMe
	Regular Air shroud			
	i   NOTE: Components support max 35°C.			
16 GB RDIMM	Silver Fan	Silver Fan	Silver Fan	Silver Fan
32 GB RDIMM	Silver Fan	Silver Fan	Silver Fan	Silver Fan
64 GB RDIMM	Silver Fan	Silver Fan	Silver Fan	Silver Fan
96 GB RDIMM	Gold Fan	Gold Fan	Gold Fan	Gold Fan
128 GB RDIMM	Gold Fan	Gold Fan	Gold Fan	Gold Fan
256 GB RDIMM	TBD	TBD	TBD	TBD

**Table 66. GPU thermal restriction matrix for Direct Liquid Cooling Non-GPU configuration**

GPU thermal restriction matrix for Direct Liquid Cooling Non-GPU configuration				
DLC Module ; Silver Fan , HPR Gold Fan				
GPU	24 x U.2	8 x 2.5-inch	16 x 2.5-inch	8 x EDSFF E3.S NVMe
	<b>Regular Air shroud</b>			
	ⓘ <b>NOTE:</b> ** Components that support max 30°C. ⓘ <b>NOTE:</b> Components without ** support max 35°C.			
L4 24 GB	HPR Gold Fan**	HPR Gold Fan	HPR Gold Fan	HPR Gold Fan

**Table 67. CPU thermal restriction matrix for Direct Liquid Cooling GPU configuration**

CPU thermal restriction matrix for Direct Liquid Cooling GPU configuration						
DLC Module, HPR Gold Fan						
CPU	cTDP	Max cTDP	Core Count	8 x 2.5-inch	16 x 2.5-inch	8 x EDSFF E3.S NVMe
				<b>GPU Air shroud</b>		
				<b>Supported at 35°C</b>		
9015	125	155	8	DLC Module HPR Gold Fan	DLC Module HPR Gold Fan	DLC Module HPR Gold Fan
9115	125	155	16	DLC Module HPR Gold Fan	DLC Module HPR Gold Fan	DLC Module HPR Gold Fan
9135	200	240	16	DLC Module HPR Gold Fan	DLC Module HPR Gold Fan	DLC Module HPR Gold Fan
9255	200	240	24	DLC Module HPR Gold Fan	DLC Module HPR Gold Fan	DLC Module HPR Gold Fan
9335	280	300	32	DLC Module HPR Gold Fan	DLC Module HPR Gold Fan	DLC Module HPR Gold Fan
9355P	280	300	32	DLC Module HPR Gold Fan	DLC Module HPR Gold Fan	DLC Module HPR Gold Fan
9455	300	300	48	DLC Module HPR Gold Fan	DLC Module HPR Gold Fan	DLC Module HPR Gold Fan
9535	300	300	64	DLC Module HPR Gold Fan	DLC Module HPR Gold Fan	DLC Module HPR Gold Fan
9175F	320	400	16	DLC Module HPR Gold Fan	DLC Module HPR Gold Fan	DLC Module HPR Gold Fan
9275F	320	400	24	TBD	TBD	TBD
9375F	320	400	32	DLC Module HPR Gold Fan	DLC Module HPR Gold Fan	DLC Module HPR Gold Fan

**Table 67. CPU thermal restriction matrix for Direct Liquid Cooling GPU configuration (continued)**

<b>CPU thermal restriction matrix for Direct Liquid Cooling GPU configuration</b>						
<b>DLC Module, HPR Gold Fan</b>						
<b>CPU</b>	<b>cTDP</b>	<b>Max cTDP</b>	<b>Core Count</b>	<b>8 x 2.5-inch</b>	<b>16 x 2.5-inch</b>	<b>8 x EDSFF E3.S NVMe</b>
				<b>GPU Air shroud</b>		
				<b>Supported at 35°C</b>		
9475F	400	400	48	DLC Module HPR Gold Fan	DLC Module HPR Gold Fan	DLC Module HPR Gold Fan
9555P	360	400	64	DLC Module HPR Gold Fan	DLC Module HPR Gold Fan	DLC Module HPR Gold Fan
9575F	400	400	64	DLC Module HPR Gold Fan	DLC Module HPR Gold Fan	DLC Module HPR Gold Fan
9655P	320	400	96	DLC Module HPR Gold Fan	DLC Module HPR Gold Fan	DLC Module HPR Gold Fan
9745	400	400	128	DLC Module HPR Gold Fan	DLC Module HPR Gold Fan	DLC Module HPR Gold Fan
9825	390	400	144	DLC Module HPR Gold Fan	DLC Module HPR Gold Fan	DLC Module HPR Gold Fan
9845	390	400	160	DLC Module HPR Gold Fan	DLC Module HPR Gold Fan	DLC Module HPR Gold Fan

**Table 68. Memory thermal restriction matrix for Liquid Cooling GPU configuration**

<b>Memory thermal restriction matrix for Liquid Cooling GPU configuration</b>			
<b>DLC Module, HPR Gold Fan</b>			
<b>memory</b>	<b>16 x 2.5-inch</b>	<b>8 x 2.5-inch</b>	<b>8 x EDSFF E3.S NVMe</b>
	<b>GPU Air shroud</b>		
	<b>Supported at 35°C</b>		
16 GB RDIMM	HPR Gold Fan	HPR Gold Fan	HPR Gold Fan
32 GB RDIMM	HPR Gold Fan	HPR Gold Fan	HPR Gold Fan
64 GB RDIMM	HPR Gold Fan	HPR Gold Fan	HPR Gold Fan
96 GB RDIMM	HPR Gold Fan	HPR Gold Fan	HPR Gold Fan
128 GB RDIMM	HPR Gold Fan	HPR Gold Fan	HPR Gold Fan
256 GB RDIMM	TBD	TBD	TBD

## Appendix B. Standards compliance

The system conforms to the following industry standards.

**Table 69. Industry standard documents**

Standard	URL for information and specifications
<b>ACPI</b> Advance Configuration and Power Interface Specification, v6.4	<a href="#">ACPI</a>
<b>Ethernet</b> IEEE Std 802.3-2022	<a href="#">IEEE Standards</a>
<b>MSFT WHQL</b> Microsoft Windows Hardware Quality Labs	<a href="#">Windows Hardware Compatibility Program</a>
<b>IPMI</b> Intelligent Platform Management Interface, v2.0	<a href="#">IPMI</a>
<b>DDR5 Memory</b> DDR5 SDRAM Specification	<a href="#">DDR5 SDRAM</a>
<b>PCI Express</b> PCI Express Base Specification, v5.0	<a href="#">PCIe specifications</a>
<b>PMBus</b> Power System Management Protocol Specification, v1.2	<a href="#">PMBus specifications</a>
<b>SMBIOS</b> System Management BIOS Reference Specification, v3.3.0	<a href="#">DMTF SMBIOS</a>
<b>TPM</b> Trusted Platform Module Specification, v2.0	<a href="#">TPM specifications</a>
<b>UEFI</b> Unified Extensible Firmware Interface Specification, v2.7	<a href="#">UEFI specifications</a>
<b>PI</b> Platform Initialization Specification, v1.7	
<b>USB</b> Universal Serial Bus v2.0 and SuperSpeed v3.0 (USB 3.1 Gen1)	<a href="#">USB document library</a>
<b>NVMe</b> Express Base Specification. Revision 2.0c	<a href="#">NVMe specifications</a>
<b>NVMe</b> Command Set Specifications	
1. NVMe Express NVM Command Set Specification. Revision 1.1c	
2. NVMe Express Zoned Namespaces Command Set. Revision 1.0c	
3. NVMe Express® Key Value Command Set. Revision 1.0c	
<b>NVMe</b> Transport Specifications	
1. NVMe Express over PCIe Transport. Revision 1.0c	
2. NVMe Express RDMA Transport Revision. 1.0b	
3. NVMe Express TCP Transport. Revision 1.0c	
<b>NVMe</b> NVMe Express Management Interface. Revision 1.2c	
<b>NVMe</b> NVMe Boot Specification. Revision 1.0	

## Appendix C: Additional resources

**Table 70. Additional resources**

Resource	Description of contents	Location
Installation and Service Manual	<p>This manual, available in PDF format, provides the following information:</p> <ul style="list-style-type: none"> <li>• Chassis features</li> <li>• System Setup program</li> <li>• System indicator codes</li> <li>• System BIOS</li> <li>• Remove and replace procedures</li> <li>• Diagnostics</li> <li>• Jumpers and connectors</li> </ul>	<a href="https://Dell.com/Support/Manuals">Dell.com/Support/Manuals</a>
Getting Started Guide	<p>This guide ships with the system, and is also available in PDF format. This guide provides the following information:</p> <ul style="list-style-type: none"> <li>• Initial setup steps</li> </ul>	<a href="https://Dell.com/Support/Manuals">Dell.com/Support/Manuals</a>
Rack Installation Guide	<p>This document ships with the rack kits, and provides instructions for installing a server in a rack.</p>	<a href="https://Dell.com/Support/Manuals">Dell.com/Support/Manuals</a>
System Information Label	<p>The system information label documents the HPM board layout and system jumper settings. Text is minimized due to space limitations and translation considerations. The label size is standardized across platforms.</p>	Inside the system chassis cover
MyDell label	<p>This code on the chassis can be scanned by a phone application to access additional information and resources for the server, including videos, reference materials, service tag information, and Dell contact information.</p>	Inside the system chassis cover
Enterprise Infrastructure Planning Tool (EIPT)	<p>The Dell online EIPT enables easier and more meaningful estimates to help you determine the most efficient configuration possible. Use EIPT to calculate the power consumption of your hardware, power infrastructure, and storage.</p>	<a href="https://Dell.com/calc">Dell.com/calc</a>

## Appendix D: Services

### Topics:

- [Why attach service contracts](#)
- [ProSupport Infrastructure Suite](#)
- [Specialty Support Services](#)
- [ProDeploy Infrastructure Suite](#)
- [Supplemental Deployment Services](#)
- [Unique Deployment Scenarios](#)
- [DAY 2 – Automation Services with Ansible](#)
- [Dell Technologies Consulting Services](#)
- [Dell Technologies Consulting Services](#)

### Why attach service contracts

Dell PowerEdge servers include a standard hardware warranty that highlights our commitment to product quality by guaranteeing repair or replacement of defective components. While industry-leading, our warranties are limited to 1 or 3 years, depending on model, and do not cover software assistance. Call records show that customers are most often seeking Dell technical support for software related issues like configuration guidance, troubleshooting, upgrade assistance or performance tuning. Encourage customers to purchase ProSupport service contracts to supplement warranty coverage and ensure optimal support for both hardware and software. ProSupport provides a complete hardware guarantee beyond the original warranty period.

### ProSupport Infrastructure Suite

ProSupport Infrastructure Suite is a set of support services that enable customers to build the solution that is right for their organization. It is an industry-leading, enterprise-class support that aligns with the criticality of your systems, the complexity of your environment, and the allocation of your IT resources.

Figure 54. ProSupport Enterprise Suite

	Basic Hardware Support <sup>1</sup>	ProSupport	BEST ProSupport Plus
<b>Outcome Assistance and Advocacy</b> via assigned Technical Customer Success Manager ⓘ			
Enjoy a frictionless customer experience with cross-functional lifecycle management aligned to your goals			✓
Accelerate time-to-value through onboarding assistance, education and success planning			✓
Turn challenges into opportunities with actionable strategies powered by data and AI-driven analytics			✓
Ensure coverage continuity while preparing to scale for future success			✓
<b>Proactive Monitoring &amp; Actionable Insights</b> via Dell's connectivity solutions and tools			
Quickly visualize performance through a current system health score		✓	✓
Cybersecurity monitoring and mitigation recommendations provide another layer of protection		✓	✓
Predictive performance and capacity analysis address bottlenecks		✓	✓
Prevent or plan for downtime with predictive hardware anomaly detection		✓	✓
Energy consumption and carbon footprint forecasting support sustainability and stewardship initiatives		✓	✓
Get ahead of problems with proactive issue detection with automated case creation	✓	✓	✓
Streamline internal IT efforts with efficient service request and escalation management tools	✓	✓	✓
Minimize disruptions by self-dispatching eligible parts	✓	✓	✓
<b>Support Essentials</b>			
Receive an assigned incident manager for Sev 1 issues who will work your issue through to resolution		✓	✓
Count on Mission Critical Support during Sev 1 incidents and natural disasters ⓘ			✓
Keep systems code current and performing at peak through Proactive System Maintenance			✓
Get priority access to senior technical support engineers—skip the queues and callbacks			✓
Bringing your own software? We provide limited 3rd party software support ⓘ			✓
Choose onsite parts delivery and labor response that meets your needs	Next Business Day	NBD or 4-hour	4-hour
Select product coverage that best augments your internal resources	Hardware	Hardware & Software	Hardware & Software
Have an issue? We are here for you by phone, chat and online	Local business hours	24/7/365	24/7/365

## ProSupport Plus for Infrastructure

ProSupport Plus for Infrastructure is the ultimate solution for customers seeking preventative maintenance and optimal performance on their business-critical assets. The service caters to customers who require proactive, predictive, and personalized support for systems that manage critical business applications and workloads. When customers purchase PowerEdge server, we recommend ProSupport Plus, our proactive and preventative support service for business-critical systems. ProSupport Plus provides all the benefits of ProSupport, including the following “Top five reasons to buy ProSupport Plus (PSP)”

- 1. Priority access to specialized support experts:** Immediate advanced troubleshooting from an engineer that understands Dell infrastructure solutions.
- 2. Mission Critical Support:** When critical (Severity 1) support issues happen, the customer is assured that we do all that we can to get them back up and running as quickly as possible.
- 3. Technical Customer Success Manager:** A customer’s #1 support advocate, ensuring they get the best possible proactive and predictive support experience.
- 4. Systems maintenance:** On a semiannual basis, we will keep a customer’s ProSupport Plus system(s) up to date by installing the latest firmware, BIOS, and driver updates to improve performance and availability.
- 5. Third-party software support:** Dell is a customer’s single point of accountability for any eligible third-party software that is installed on their ProSupport Plus system, whether they purchased the software from us or not.

## ProSupport for Infrastructure

Comprehensive 24x7 support for hardware and software – best for production, but not critical, workloads and applications. The ProSupport service offers highly trained experts around the clock and around the globe to address IT needs. We help minimize disruptions and maximize availability of PowerEdge server workloads with:

- 24x7 support through phone, chat and online
- A central point of accountability for all hardware and software issues
- Hypervisor, operating system, and application support
- Dell security advisories

- Onsite response service levels 4 hour or Next Business Day options
- Proactive issue detection with automated case creation
- Predictive hardware anomaly detection
- Incident Manager assigned for Severity 1 cases
- Collaborative third-party support
- Access to AIOps Platforms - (MyService360, TechDirect, and CloudIQ)
- Consistent experience regardless of where customers are located or what language that they speak.

## Basic Hardware Support

Provides reactive hardware support during normal business hours, excluding local national holidays. No software support or software-related guidance. For improved levels of support, choose ProSupport or ProSupport Plus.

## Specialty Support Services

Optional specialty support services complement the ProSupport Infrastructure Suite to provide additional proficiencies that are critical for modern data center operations.

### Hardware coverage add-ons to ProSupport or ProSupport Plus

- **Keep Your Hard Drive (KYHD), Keep Your Component (KYC), or Keep Your GPU (KYGPU):**

Normally if a device fails under warranty, Dell replaces it using a one-for-one exchange process. KYHD/KYCC/KYGPU gives you the option to retain your device. It provides full control of sensitive data and minimizes security risk by letting you retain possession of failed drives, components, or GPU when receiving replacement parts without incurring additional cost.

- **Onsite Diagnosis Service:**

Ideal for sites with non-technical staff. Dell field technician performs initial troubleshooting diagnosis onsite and transfers to Dell remote engineers to resolve the issue.

- **ProSupport Add-on for HPC:**

Sold as an add-on to a ProSupport service contract, the ProSupport Add-on for HPC provides solution-aware support to cover the additional requirements that are required to maintain an HPC environment such as:

- Access to senior HPC experts
- Advanced HPC cluster assistance: Performance, interoperability, and configuration
- Enhanced HPC solution level end-to-end support
- Remote pre-support engagement with HPC Specialists during ProDeploy implementation

- **ProSupport Add-on for Telco (Respond & Restore):**

An add-on service designed for the top 31 TELCO customers globally, Respond & Restore provides direct access to Dell solution experts who specialize in TELCO carrier-grade support. This add-on also provides a hardware uptime guarantee, meaning if a system fails, Dell has it installed and operational within 4 hours for Severity 1 issues. Dell incurs penalties and fees if SLAs are not met.

### Personalized Support and Supplemental Site-wide Expertise

- **Technical Account Manager:**

Designated technology lead who monitors and manages the performance and configuration of specific technology sets.

- **Designated Remote Support:**

Personalized support expert who manages all troubleshooting and resolution of IT assets.

- **Multivendor Support Service:**

Support your third-party devices as one service plan for servers, storage, and networking (includes coverage for: Broadcom, Cisco, Fujitsu, HPE, Hitachi, Huawei, IBM, Lenovo, NetApp, Oracle, Quanta, SuperMicro and others).

## Services for large enterprises

- **ProSupport One for Data Center:**

ProSupport One for Data Center offers flexible site-wide support for large and distributed data centers with more than 1,000 assets (combined total of server, storage, networking, so forth). This offering is built on standard ProSupport features that leverage our global scale and are tailored to specific customer needs. While not for everyone, this service option offers a truly unique solution for our largest customers with the most complex environments.

- Team of assigned Services Account Managers with remote or onsite options
- Assigned technical and field engineers who are trained on the customer's environment and configurations.
- On-demand reporting and recommendations that are enabled by ProSupport AIOps tools (MyService360, TechDirect, and CloudIQ)
- Flexible onsite support and parts options that fit their operational model
- A tailored support plan and training for their operations staff

- **ProSupport One for Data Center – CSP (Cloud Serviced Provider) and AI Solution**

ProSupport One for Data Center – CSP and AI Solution is a unique offer that is designed for a limited set of Dell accounts purchasing AI computing solutions greater than 1,000 servers and \$250M in sales. PS1DC - CSP and AI improves the entire services experience combining support, deployment (rack integration), residency services, a designated support engineer, an onsite service engineer, and an onsite parts service as one holistic offer. Special pricing has been determined to compete effectively against competitors and provide the best customer experience. PS1DC for CSP and AI can only be sold with XE Servers and all networking platforms (Dell and NVIDIA). All other products would be eligible for the standard PS1DC, not this unique offer. More details on PS1DC for CSP and AI [here](#).

- **Onsite Parts Service (OPS)**

Ideal for large organizations that have their own staff to support their data center. Dell offers a service that is called Onsite Parts Service (OPS) from Dell Services. OPS manages parts inventory located at the customer's designated facility. The Logistics Online Inventory Solution (LOIS) program will use software to support the monitoring and automatic replenishment of inventory stored on the customer site. . Each replacement part would automatically initiate a replenishment of the parts inventory that is shipped the next day or delivered onsite by Dell during a regular scheduled visit (called Scheduled Onsite Service). As part of the LOIS system, customers can integrate their systems directly to Dell TechDirect using APIs to help streamline the support management process.

## End-of-Life Services

- **Post Standard Support (PSS)**

Extend service life beyond the initial seven years of ProSupport, adding up to five more additional years of hardware coverage.

- **Data Sanitization & Data Destruction**

Renders data unrecoverable on repurposed or retired products, ensuring security of sensitive data and enabling compliance and provides NIST-compliant certification.

- **Asset Recovery Services**

Recycle, resale, and disposal of hardware. Helps you securely and responsibly retire IT assets that are no longer needed while protecting both your business and the planet.

## ProDeploy Infrastructure Suite

ProDeploy Infrastructure Suite provides various deployment offerings that satisfy a customer's unique needs. It is made up of various sub-offers: Factory Configuration Services, Rack Integration, Basic Deployment, ProDeploy, ProDeploy Plus, and optionally ProDeploy FLEX which allows for some customization of the features listed.

# ProDeploy Infrastructure Suite

Versatile choices for accelerated deployments

NOTE: All XE Series servers require mandatory deployment

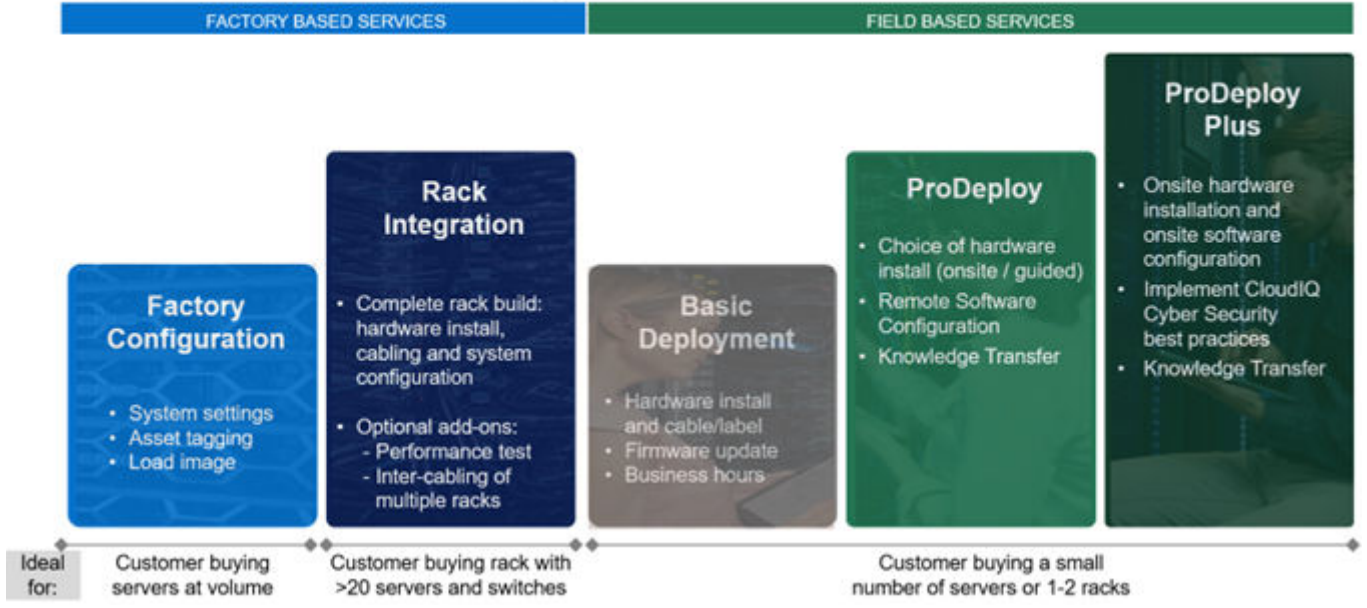

Figure 55. ProDeploy Infrastructure Suite

## Factory-based Services

Pre-configured systems or complete racks, customized prior to shipping to the customer's site.

### Customer Rack Integration or ProDeploy FLEX Rack Integration

Dell offers robust custom rack integration services through two main programs: Enterprise Rack Integration Services and Integrated Rack Scalable Systems (IRSS). These services are designed to streamline deployment, reduce complexity, and optimize performance for data centers, edge environments, and AI workloads. These factory services are purchased as a custom engagement or as ProDeploy Flex Rack Integration SKUs.

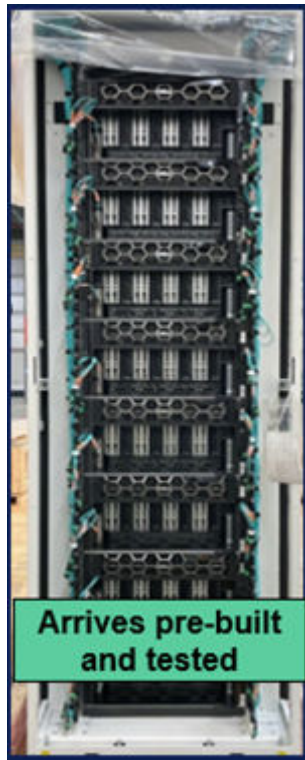

Figure 56. Pre-configured system



Figure 57. Pre-configured system

### Factory Configuration

Ideal for customers buying servers in volume and seeking pre-configuration prior to shipping such as: custom image, system settings, and asset tagging so it arrives ready to use out of the box. Furthermore, servers are packaged and bundled to meet specific shipping and distribution requirements for each customer location to facilitate the rollout process. Once the server is onsite, Dell can install and configure the server to the environment using any of the field-based deployment services outlined in the next section.

## Field-based services

Put PowerEdge servers to work faster with Dell field-based deployment services. Whether we are deploying one server to one thousand – we have you covered. Dell provides versatile delivery options to fit every budget and operating model.

- **ProDeploy Plus:** Elevate Infrastructure deployments with our most complete service from planning through onsite hardware installation and software configuration including the implementation of cybersecurity best practices. ProDeploy Plus provides the skill and scale that is needed to successfully execute demanding deployments in today's complex IT environments. The deployment starts with a site readiness review and implementation plan. Certified deployment experts perform the software configuration to include setup of leading operating systems and hypervisors. Dell will also configure PowerEdge software tools to include iDRAC and OpenManage system utilities as well as support AI/Ops platforms: MyService360, TechDirect, and

CloudIQ. Unique to ProDeploy Plus, the cybersecurity implementation helps customers understand potential security risks and make recommendations for reducing product attack surfaces. The system is tested, validated prior to completion. The customer will also receive full project documentation and knowledge transfer to complete the process.

- **ProDeploy:** ProDeploy provides remote software configuration and choice of hardware installation (onsite or guided). ProDeploy is great for customers who are price sensitive or willing to participate in some portion of the deployment to include providing remote access to their network. The ProDeploy remote software includes everything mentioned in ProDeploy Plus except it does not include the added value, cybersecurity implementation, and implementation best practices.
- **Basic Deployment:** Basic Deployment delivers worry-free professional installation by experienced technicians. This service is often sold to Competency Enabled Partners who will have Dell do the hardware installation while they complete the software configuration. Furthermore, Basic Deployment tends to be purchased by large enterprises who have smart technical staff. These companies just need Dell to install the hardware, and they will perform the software configuration. The last use case for Basic Deployment is when paired with Factory Configuration services. The servers are preconfigured in the factory, and the basic deployment service will install the system into the rack to finalize the deployment.

## ProDeploy Infrastructure Suite | Field services

		Basic Deployment	ProDeploy	ProDeploy Plus
<b>Pre-deployment</b>	Single point of contact for project management	-	●	In region
	Site readiness review and implementation planning	-	●	●
<b>Deployment</b>	Deployment service hours	Business hours	24/7	24/7
	Hardware installation options	Onsite	Onsite or guided <sup>1</sup>	Onsite
	System software installation and configuration options	-	Remote	Onsite
	Install connectivity software based on Secure Connect Gateway technology <sup>2</sup>	-	●	●
	Implement CyberSecurity best practices and policies in APEX AIOps Infrastructure Observability	-	-	●
<b>Post-deployment</b>	Deployment verification, documentation and knowledge transfer	-	●	●
	Configuration data transfer to Dell technical support	-	●	●
<b>Online collaboration</b>	Online collaborative platform in TechDirect for planning, managing and tracking delivery	-	●	●

<sup>1</sup> Choose from onsite hardware installation or a guided option including project specific instructions, documentation and live expert guidance  
<sup>2</sup> Post deployment use for intelligent, automated support & insights

Figure 58. ProDeploy Infrastructure Suite - Field services

## Supplemental Deployment Services

Additional ways to expand scope or deploy for unique scenarios.

### Two Host Adder (requires PD/PDP)

Deploying new storage, compute, or networking devices may require interconnection to other servers (also called hosts). The Dell delivery team will set up four hosts per device as part of every ProDeploy service. For example, if the customer is buying two storage arrays the ProDeploy service will automatically include connectivity of four hosts each (4x2=8 total hosts per project since there are two devices). This supplemental "Two Host Adder" service provides for the configuration of additional hosts above what is already provided as part of the ProDeploy service. In many cases, customers can work with us while we set up the included hosts, so they may understand how to do the rest themselves. Always ask the customer how many hosts are being connected and sell the host adder depending on the customer's technology skillset. Note that this service applies to the connectivity of Dell devices not 3rd party devices.

### Additional Deployment Services (ADT) – sold with or without PD/PDP

You can expand the scope of a ProDeploy engagement leveraging Additional Deployment Time (ADT). ADT covers additional tasks above the normal deliverables of the ProDeploy offers. ADT can also be used as a standalone service without ProDeploy.

SKUs are available for both Project Management and Technical Resource Expertise. SKUs are sold as blocks of four hours remote or eight hours onsite. The delivery team can help in scoping the number of hours required for additional tasks.

## Data Migration Services

Migrating data sets is no easy task. Our experts use proven tools and process to streamline data migrations and avoid compromising data. A customer project manager works with our experienced team of experts to create a migration plan. Data migration is part of every technology upgrade, platform change, and shift to the cloud. You can rely on Dell data migration services to perform a seamless transition.

## Residency Services

Certified technical professionals act like an extension of your IT staff to enhance internal capabilities and resources and help you realize faster adoption and maximized ROI of new technology. Residency Services help customers transition to new capabilities quickly by leveraging specific technology skill sets. Residency experts can provide post implementation management and knowledge transfer that is related to a new technology acquisition or day-to-day operational management of the IT infrastructure.

- Global experts available to serve in-person (onsite) or virtual (remote)
- Engagements starting at 2 weeks with flexibility to adjust
- Residency is available for project management needs, and many different technology skills sets such as: Server, storage, Gen AI, networking, security, multi-cloud, data mgmt., and modern workforce application residents

## Unique Deployment Scenarios

### Custom Deployment Services

When a deployment is beyond the scope of the ProDeploy Infrastructure Suite, you can turn to the custom deployment services team to address complex implementation scenarios and customer unique requirements. The Dell custom deployment team is staffed with solution architects who will assist with customer scoping calls to define the project and develop the statement of work. Custom services can handle a wide range of deployments that can be performed in the factory or onsite. All custom engagement services are requested through SFDC.

### Deployment of AI or HPC using Cluster Build Services

Once the integrated rack arrives the data center or is built onsite, Dell can also convert the racks into a large computing cluster. Dell provides several deploy options for Artificial Intelligence (AI) or High-Performance Computing (HPC) implementations. These complex environments require specialists that understand advanced feature sets to create a unified computing cluster for the most demanding workloads. Choose one of the cluster build add-ons below.

Increase Time to Value and with ProDeploy Flex and Cluster Builds

Sell as Custom Quote or Standard SKUs  
Add-ons 1 & 2 arriving as standard SKUs in Sept.

**ProDeploy Flex Rack Integration or ProDeploy Flex Onsite** + **Cluster Build Add-ons**  
Select one or more add-ons below

		Ideal for
	<b>1 Physical Configuration of Cluster</b> <ul style="list-style-type: none"> <li>Onsite Infrastructure Assessment</li> <li>Installation of switches<sup>1</sup></li> <li>Inter-rack cabling and labeling</li> <li>Liquid connectivity and leak test<sup>2</sup></li> </ul>	Customers needing help with installing the network, inter-rack cabling, and fabric testing
	<b>2 Logical Configuration of Cluster</b> <ul style="list-style-type: none"> <li>Review system design and plan</li> <li>Configure switches &amp; mgmt nodes</li> <li>Validation and acceptance testing</li> </ul>	Customers requiring cluster configuration and essential testing of the solution
	<b>3 AI Network Design Services</b> <ul style="list-style-type: none"> <li>2-week intensive consultation that accelerates AI network performance and maximizes operational efficiency<sup>3</sup></li> </ul>	Customers seeking foundational design strategy to achieve optimal performance

When the environment is demanding, your configuration can't be average ★★★★★

**Key Benefits:**

- Factory rack integration enables faster time to value and reliability
- Reduce onsite setup time and fast track to production
- Fine-tuned system performance based on workload types
- Services aligned with enterprise-grade security standards
- Final testing and customer handoff lessen amount of support calls

1 -- Network switches to be installed in factory or onsite depending on requirements. Choose options: ProDeploy Flex Rack Integration or ProDeploy Flex Onsite combined with PD Flex Cluster Add-ons  
2 -- If applicable. Leak test performed in factory and again onsite which is limited to in-rack CXK!  
3 -- AI Network Design Service is ordered as a Custom Service Engagement via SFDC or SFP

Figure 59. Deployment choices for cluster implementation

## DAY 2 – Automation Services with Ansible

Dell solutions are built as “automation ready” with integrated APIs (Application Programming Interfaces) to allow customers to programmatically call actions on the product through code. Although Dell has published Ansible automation use cases, some customers need additional assistance with GitOps. By the end of the service, the customer will have the foundational components required to accelerate automation and understand how the programming works together: Day 1 and Day 2 use case automation scripts (ansible modules), CI/CD tool (Jenkins), and Version control (Git).

## Dell Technologies Consulting Services

Our expert consultants help customers transform faster, and quickly achieve business outcomes for the high-value workloads Dell PowerEdge systems can handle. From strategy to full-scale implementation, Dell Technologies Consulting can help you determine how to perform IT, workforce, or application transformation. We use prescriptive approaches and proven methodologies that are combined with the portfolio and partner ecosystem of Dell Technologies to help achieve real business outcomes. From multicloud, applications, DevOps, and infrastructure transformations, to business resiliency, data center modernization, analytics, workforce collaboration, and user experiences—we are here to help.

### Dell Managed Services

Some customers prefer Dell to manage the complexity and risk of daily IT operations, Dell-Managed Services uses proactive, AI enabled delivery operations and modern automation to help customers realize desired business outcomes from their infrastructure investments. With these technologies, our experts run, update, and fine-tune customer environments that are aligned with service levels, while providing environment-wide and down-to-the-device visibility. There are two types of managed service offers. First the outsourcing model or CAPEX model where Dell manages the customer-owned assets using our people and tools. The second is the as-a-Service model or OPEX model called APEX. In this service, Dell owns all technology and all the management of it. Many customers will have a blend of the two management types depending on the goals of the organization.

Managed	Outsourcing or CAPEX model	APEX	as-a-Service or OPEX model
<p>We manage your technology using our people and tools.<sup>1</sup></p> <ul style="list-style-type: none"> <li>• Managed detection and response*</li> <li>• Technology Infrastructure</li> <li>• End-user (PC/desktop)</li> <li>• Service desk operations</li> <li>• Cloud Managed (Pub/Private)</li> <li>• Office365 or Microsoft Endpoint</li> </ul>		<p>We own all technology so you can off-load all IT decisions.</p> <ul style="list-style-type: none"> <li>• APEX Cloud Services</li> <li>• APEX Flex on Demand elastic capacity</li> <li>• APEX Data Center Utility pay-per-use model</li> </ul>	

1 – Some minimum device counts may apply. Order via: [ClientManagedServices.sales@dell.com](mailto:ClientManagedServices.sales@dell.com)

\* Managed detection and response covers the security monitoring of laptops, servers, & virtual servers. Min. 50 devices combined. No Networking or Storage-only systems [SAN/NAS]. Available in 32 countries. [Details here](#)

Figure 60. Dell Managed Services

## Managed Detection and Response (MDR)

Dell Technologies Managed Detection and Response (MDR) is powered by Secureworks Taegis XDR software platform. MDR is a managed service that secures the customer's IT environment against malicious actors and provides remediation if and when a threat is identified. When a customer purchases MDR, they receive the following features from our team:

- Dell badge resources
- Agent rollout assistance to help deploy the Secureworks Endpoint Agent
- 24x7 threat detection & investigation
- Up to 40 hrs per quarter of response and active remediation activities
- If the customer experiences a breach, we will provide up to 40 hrs per year of Cyber incident response initiation
- Quarterly reviews with the customer to review the data

## Dell Technologies Education Services

Build the IT skills required to influence the transformational outcomes of the business. Enable talent and empower teams with the right skills to lead and perform transformational strategy that drives competitive advantage. Leverage the training and certification that is required for real transformation.

Dell Technologies Education Services offers PowerEdge server training and certifications that are designed to help customers achieve more from their hardware investment. The curriculum delivers the information and the practical, firsthand skills that their team must confidently install, configure, manage, and troubleshoot Dell servers.

To learn more or register for a class today, see [Education.Dell.com](http://Education.Dell.com).

## Dell Technologies Consulting Services

Our expert consultants help customers transform faster, and quickly achieve business outcomes for the high-value workloads Dell PowerEdge systems can handle. From strategy to full-scale implementation, Dell Technologies Consulting can help determine how to perform IT, workforce, or application transformation. We use prescriptive approaches and proven methodologies that are combined with the portfolio and partner ecosystem of Dell Technologies to help achieve real business outcomes. From multicloud, applications, DevOps, and infrastructure transformations, to business resiliency, data center modernization, analytics, workforce collaboration, and user experiences—we are here to help.

## Dell Managed Services

Some customers prefer Dell to manage the complexity and risk of daily IT operations, Dell Managed Services utilizes proactive, AI enabled delivery operations and modern automation to help customers realize desired business outcomes from their infrastructure investments. With these technologies, our experts run, update, and fine-tune customer environments that are aligned with service levels, while providing environment-wide and down-to-the-device visibility. There are two types of managed service offers. First the outsourcing model or CAPEX model where Dell manages the customer owned assets using our people and tools. The second is the as-a-Service model or OPEX model called APEX. In this service, Dell owns all technology and all the management of it. Many customers will have a blend of the two management types depending on the goals of the organization.



Figure 61. Dell Managed Services

## Cyber-Security Services

### Managed Detection and Response (MDR)

Dell Managed Detection and Response Pro Plus is our fully-managed, 360° security operations solution comprised of our most cutting-edge, preventive and responsive cybersecurity services. MDR Pro Plus was designed with your top security concerns in mind, allowing you to focus on your core business goals while Dell handles your security operations. First, we have Vulnerability Management. With this service, we'll do ongoing scanning of the customer's environment looking for software that needs to be patched. Next is Pen Testing and Attack Simulation Management. This service will continuously validate security controls and policies with automated Breach and Attack Simulation (BAS), because a misconfiguration can lead to an exposure which an attacker can exploit. The service also includes an annual penetration test to determine if a skilled threat actor could exploit pathways leading to critical assets or data. Third, Managed Security Awareness Training. This service will educate the customer's end users so that they don't inadvertently put the customer at risk. If you think about our annual compliance training modules, there is always a security module. This is the same type of thing, but rather than once a year, it will be smaller, bite-size pieces of content delivered throughout the year. Fourth is our Managed Detection and Response service which provides 24x7 threat detection and investigation, analysis of end-to-end activity by threat actors, threat hunting, and quick initiation of cyber incident response when needed. Customers can choose between Secureworks Taegis XDR, CrowdStrike Falcon XDR or Microsoft Defender XDR as the security analytics platform our analysts will use to monitor their environment. All four of these services are delivered by experienced, certified Dell security experts using advanced technology such as the Secureworks Taegis XDR, CrowdStrike Falcon XDR or Microsoft Defender XDR security platforms.

## Dell Technologies Education Services

Build the IT skills required to influence the transformational outcomes of the business. Enable talent and empower teams with the right skills to lead and perform transformational strategy that drives competitive advantage. Leverage the training and certification that is required for real transformation.

Dell Technologies Education Services offers PowerEdge server training and certifications that are designed to help customers achieve more from their hardware investment. The curriculum delivers the information and the practical, firsthand skills that their team must confidently install, configure, manage, and troubleshoot Dell servers.

To learn more or register for a class today, see [Education.Dell.com](https://www.dell.com/education).

## Resources

[Service for powerEdge](#)