



HPE ProLiant DL320 Gen11 Server User Guide

Part Number: 30-676781BE-008

Published: April 2026

Edition: 8

HPE ProLiant DL320 Gen11 Server User Guide

Abstract

This document is for the person who installs, administers, and troubleshoots servers and storage systems. Hewlett Packard Enterprise assumes you are qualified in the servicing of computer equipment and trained in recognizing hazards in products with hazardous energy levels, and are familiar with the weight and stability precautions for rack installations.

Part Number: 30-676781BE-008

Published: April 2026

Edition: 8

© Copyright 2023–2026 Hewlett Packard Enterprise Development LP

Notices

The information provided here is subject to change without notice. Hewlett Packard Enterprise's products and services are covered only by the express warranty statements that come with them. This document does not constitute an additional warranty. Hewlett Packard Enterprise is not responsible for any technical or editorial errors or omissions in this document.

Confidential computer software. You must have a valid license from Hewlett Packard Enterprise to possess, use, or copy the software. In accordance with FAR 12.211 and 12.212, Commercial Computer Software, Computer Software Documentation, and Technical Data for Commercial Items are licensed to the U.S. Government under the vendor's standard commercial license.

Links to third-party websites will take you outside of the Hewlett Packard Enterprise website. Hewlett Packard Enterprise has no control over and is not responsible for the information outside the Hewlett Packard Enterprise website.

Acknowledgments

Intel®, Xeon®, and Intel® Virtual RAID on CPU (Intel® VROC) are trademarks of Intel Corporation or its subsidiaries.

Microsoft®, Windows®, and Windows Server® are either registered trademarks or trademarks of Microsoft Corporation in the United States and/or other countries.

NVIDIA®, the NVIDIA logo, and GeForce® are trademarks and/or registered trademarks of NVIDIA Corporation in the U.S. and other countries.

Linux® is the registered trademark of Linus Torvalds in the U.S. and other countries.

VMware® is a registered trademark of VMware, Inc in the United States and other jurisdictions.

All third-party marks are property of their respective owners.

Table of contents

Component identification.....	10
Front panel components.....	11
iLO Service Port.....	14
Front panel LEDs and buttons.....	15
Server UID LED.....	16
Viewing the Server Health Summary.....	16
Front panel LED power fault codes.....	17
Rear panel components.....	18
Monitor setup.....	19
Rear panel LEDs.....	19
Component touchpoints.....	20
System board components.....	22
System maintenance switch.....	24
DIMM label identification.....	25
DIMM slot numbering.....	26
Heatsink and processor socket components.....	27
Riser board components.....	28
PCIe5 slot description.....	29
PCIe switch board components.....	31
Accelerator slot numbering.....	32
HPE Basic Drive LED definitions.....	33
EDSFF SSD LED definitions.....	35
Drive box identification.....	36
Drive bay numbering.....	38
SFF drive bay numbering.....	39
LFF drive bay numbering.....	41
E3.S drive bay numbering.....	42
Drive backplane naming.....	42
Fan numbering.....	43
Fan and heatsink requirements.....	44
Trusted Platform Module 2.0.....	44
Trusted Platform Module 2.0 guidelines.....	45
BitLocker recovery key/password retention guidelines.....	45
HPE NS204i-u Boot Device components.....	46

HPE NS204i-u Boot Device LED definitions	47
Setup.....	48
Initial system installation.....	48
HPE Installation Service.....	49
Intel VROC support.....	49
Setting up the server.....	50
Operational requirements.....	52
Space and airflow requirements.....	53
Temperature requirements.....	54
Power requirements.....	54
Electrical grounding requirements.....	55
Rack warnings and cautions.....	56
Server warnings and cautions.....	58
Electrostatic discharge.....	59
Operations.....	59
Power up the server.....	60
Power down the server.....	60
Open the cable management arm.....	61
Extend the server out of the rack.....	62
Remove the server from the rack.....	64
Remove the front bezel.....	65
Remove the access panel.....	67
Remove the M.2 air baffle.....	69
Remove the middle cover.....	70
Remove the fan.....	73
Remove the fan wall.....	74
Remove the riser cage.....	77
Install the access panel.....	79
Install the M.2 air baffle.....	80
Install the middle cover.....	80
Install the fan wall.....	82
Install the riser cage.....	84
Install the server into the rack.....	86
Hardware options installation.....	88
Server data backup.....	88
Hardware option installation guidelines.....	90
Hewlett Packard Enterprise product QuickSpecs.....	90
Rack mounting options.....	91

Rack mounting interfaces.....	91
Rail identification markers.....	91
Rack rail options.....	94
Installing the rack rail option.....	94
Installing the rack rail hook-and-loop strap.....	99
Installing the cable management arm.....	100
Installing the front bezel.....	107
Drive options.....	108
Drive installation guidelines.....	109
Installing a hot-plug SAS, SATA or NVMe drive.....	110
Installing a hot-plug drive in box three or box five.....	113
Installing an E3.S drive.....	117
Installing the 8 SFF drive backplane.....	119
Drive cage options.....	124
Installing the 2 SFF drive cage.....	125
Installing the 4 SFF drive cage.....	128
Installing the E3.S drive cage.....	132
Optical drive option.....	135
Installing an optical drive in the SFF drive chassis.....	136
Installing an optical drive in the LFF drive chassis.....	140
Display port option.....	145
Installing an 8 SFF display port/USB/optical blank option.....	145
Installing the 4 LFF display port/USB option.....	149
PCIe riser option.....	152
Installing a riser board in the secondary riser cage.....	153
Power supply options.....	155
Power supply warnings and cautions.....	156
DC power supply warnings and cautions.....	157
DC power supply wire colors.....	158
Connecting a DC power cable to a DC power source.....	158
Installing a DC power supply.....	161
Installing an AC power supply.....	171
Transceiver option.....	174
Transceiver warnings and cautions.....	175
Installing a transceiver.....	175
Fan options.....	177
Fan mode behavior.....	178
Installing a fan.....	178

Expansion card options.....	180
Installing an expansion card.....	181
GPU options.....	184
Installing an accelerator in the GPU riser cage.....	185
Installing an accelerator in the rear riser cage.....	190
Energy pack option.....	193
HPE Smart Storage Hybrid Capacitor.....	194
Installing an energy pack.....	194
Memory options.....	196
DIMM population information.....	197
HPE SmartMemory speed information.....	197
Installing a DIMM.....	197
Storage controller options.....	199
Preparing the server for storage controller installation.....	200
Installing a type-p controller.....	201
Installing a type-o storage controller.....	203
OCP NIC 3.0 option.....	207
Installing the OCP NIC 3.0 adapter.....	208
HPE NS204i-u Boot Device option.....	211
Installing the HPE NS204i-u Boot Device.....	212
M.2 SSD options.....	221
Installing an M.2 SSD.....	222
Processor heatsink assembly option.....	225
Processor cautions.....	226
Installing a processor heatsink assembly.....	226
Reconfiguring the system date and time settings.....	239
Serial port option.....	240
Installing the serial port.....	240
Chassis intrusion detection switch option.....	243
Installing the chassis intrusion detection switch.....	244
Internal USB device option.....	246
Installing an internal USB device.....	247
Configuration resources.....	248
Updating firmware or system ROM.....	248
Configuring the server.....	249
Configuring storage controllers.....	251
Deploying an OS.....	253
Configuring security.....	254

Server management.....	254
Managing Linux-based high performance compute clusters.....	255
Cabling.....	255
Cabling guidelines.....	256
Internal cabling management.....	259
Cabling diagrams.....	259
Storage cabling.....	262
Drive power cabling.....	263
Storage controller cabling.....	269
2 SFF drive controller cabling.....	270
4 SFF drive controller cabling.....	273
4 E3.S drive controller cabling.....	275
8 E3.S drive controller cabling.....	276
8 SFF drive controller cabling.....	278
4 LFF drive controller cabling.....	287
10 LFF drive controller cabling.....	289
12 LFF drive controller cabling.....	290
Energy pack cabling.....	291
Storage controller backup cabling.....	291
Accelerator cabling.....	293
GPU auxiliary power cabling.....	294
GPU riser cabling.....	295
HPE NS204i Boot Device cabling.....	299
Switch board cabling.....	301
Optical drive cabling.....	304
Display port cabling.....	306
Serial port cabling.....	308
Front I/O cabling.....	309
VGA cabling.....	312
Chassis intrusion detection switch cabling.....	313
Troubleshooting.....	313
NMI functionality.....	314
Troubleshooting resources.....	314
Safety, warranty, and regulatory information.....	314
Regulatory information.....	315
Notices for Eurasian Economic Union.....	315
Turkey RoHS material content declaration.....	316
Ukraine RoHS material content declaration.....	317

Warranty information.....	317
Specifications.....	317
Environmental specifications.....	317
Mechanical specifications.....	318
Power supply specifications.....	319
HPE 500 W Flex Slot Platinum Hot-plug Low Halogen Power Supply.....	320
HPE 800 W Flex Slot Platinum Hot-plug Low Halogen Power Supply.....	321
HPE 1000 W Flex Slot Titanium Hot-plug Power Supply.....	322
HPE 1600 W Flex Slot -48 VDC Hot-plug Power Supply.....	322
Websites.....	323
Support and other resources.....	323
Accessing Hewlett Packard Enterprise Support.....	324
HPE product registration.....	324
Accessing updates.....	325
Customer self repair.....	325
Remote support.....	326
Documentation feedback.....	326

Component identification

This chapter describes the external and internal server features and components.

Subtopics

Front panel components

Front panel LEDs and buttons

Rear panel components

Rear panel LEDs

Component touchpoints

System board components

Riser board components

PCIe5 slot description

PCIe switch board components

Accelerator slot numbering

HPE Basic Drive LED definitions

EDSFF SSD LED definitions

Drive box identification

Drive bay numbering

Drive backplane naming

Fan numbering

Fan and heatsink requirements

Trusted Platform Module 2.0

HPE NS204i-u Boot Device components

HPE NS204i-u Boot Device LED definitions

Front panel components

SFF drive configuration

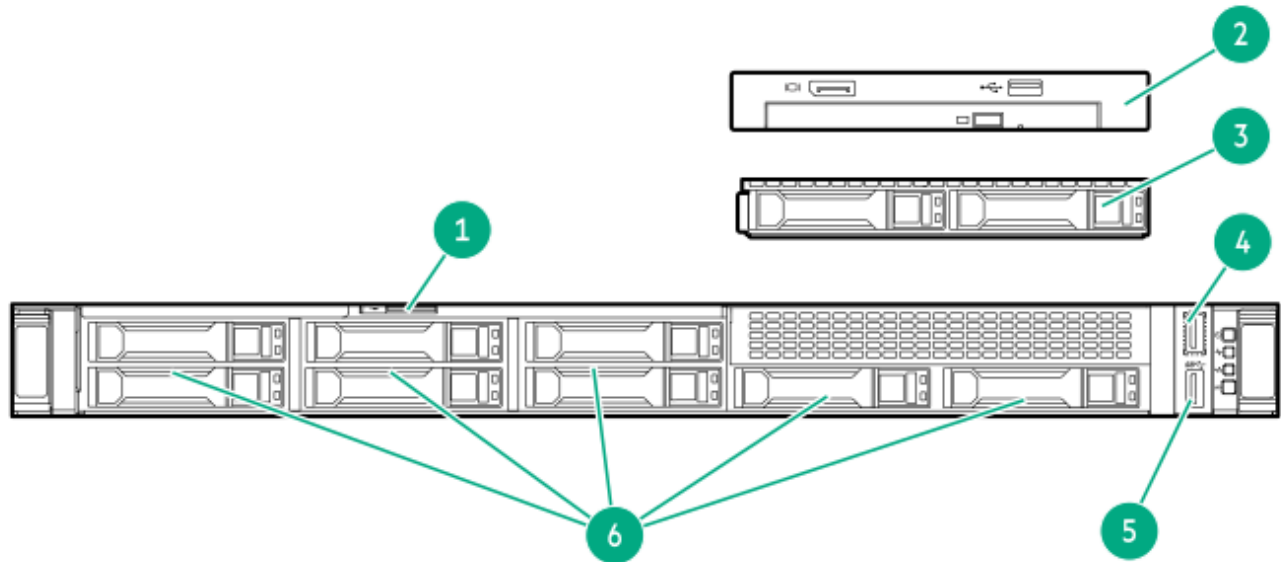

Item	Description
1	Serial number/iLO information pull tab ¹
2	ODD/display port + USB (optional) ²
3	2 SFF side-by-side drive cage assembly (optional)
4	<u>iLO Service Port</u>
5	USB 3.2 Gen1 port
6	8 SFF drives

¹ The serial number/ iLO information pull tab is double-sided. One side shows the server serial number and the customer asset tag label. The other side shows the default iLO account information.

² This drive cage assembly includes in the front USB and DisplayPort option.

The server supports two 2 SFF drive cage options. The following drive types are supported: SATA, SAS, U.2 NVMe, and U.3 NVMe drives.

4 LFF drive configuration

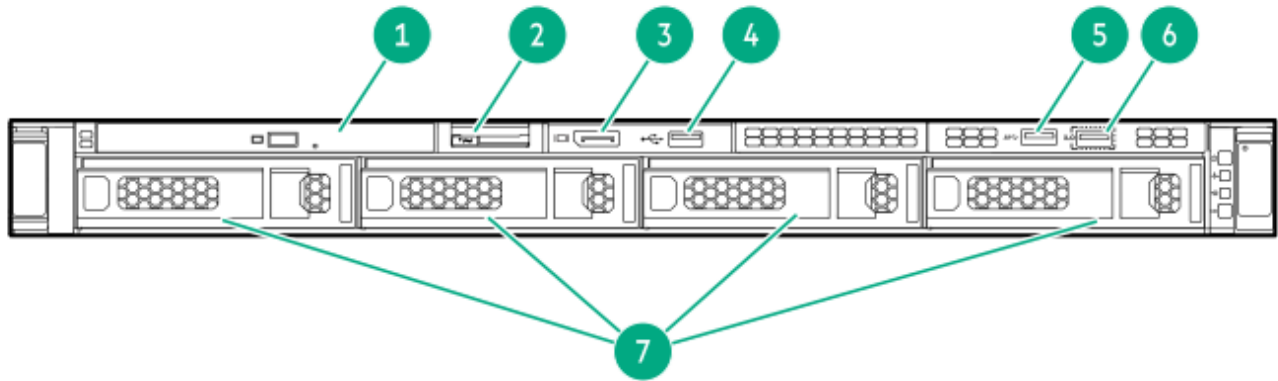

Item	Description
1	ODD (optional)
2	Serial number/iLO information pull tab
3	Display port 1.1a (optional)
4	USB 2.0 port (optional)
5	USB 3.2 Gen1 port
6	iLO Service Port
7	4 LFF drives

12 LFF drive configuration

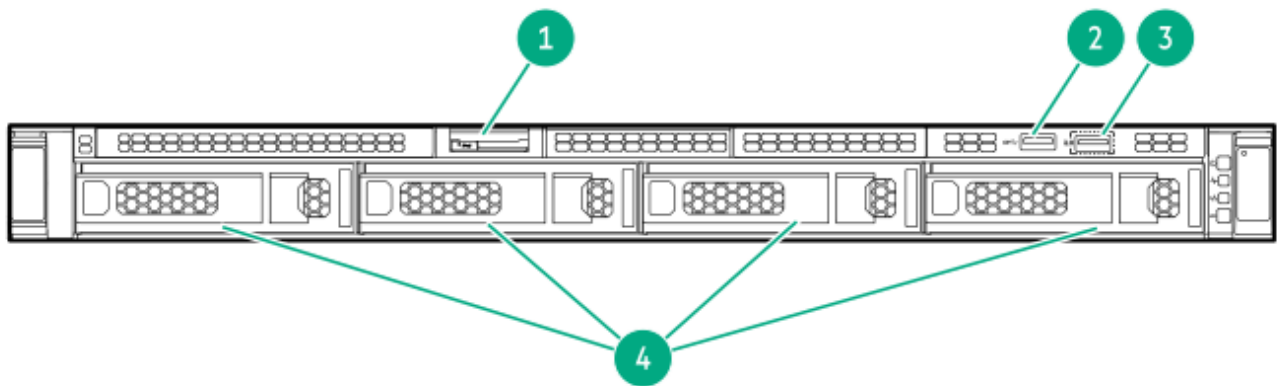

Item	Description
1	Serial number/iLO information pull tab
2	USB 3.2 Gen1 port
3	<u>iLO Service Port</u>
4	4 LFF drives

4 SFF drives with a GPU riser cage

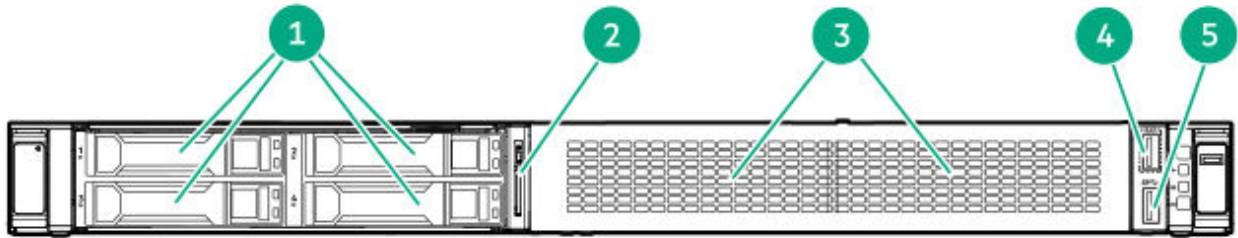

Item	Description
1	4 SFF drives
2	Serial number/ iLO information pull tab
3	GPU riser cage
4	<u>iLO Service Port</u>
5	USB 3.2 Gen1 port

8 E3.S drives with a GPU riser cage

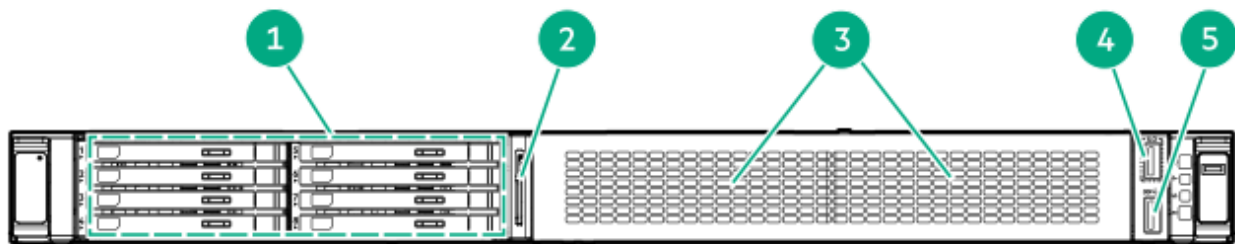

Item	Description
1	8 E3.S drives
2	Serial number/iLO information pull tab

Item	Description
3	GPU riser cage
4	<u>iLO Service Port</u>
5	USB 3.2 Gen1 port

Subtopics

iLO Service Port

iLO Service Port

The Service Port is a USB port with the label **iLO** on supported servers and compute modules.

To find out if your server or compute module supports this feature, see the server specifications document at the following website: <https://www.hpe.com/info/quickspecs>.

The Service Port is a USB port with the label **iLO** on the front of the server.

To find out if your server supports this feature, see the server specifications document at the following website: <https://www.hpe.com/info/quickspecs>.

When you have physical access to a server, you can use the Service Port to do the following:

- Download the Active Health System Log to a supported USB flash drive.

When you use this feature, the connected USB flash drive is not accessible by the host operating system.

- Connect a client (such as a laptop) with a supported USB to Ethernet adapter to access the following:
 - iLO web interface
 - Remote console
 - iLO RESTful API
 - CLI

Hewlett Packard Enterprise recommends the HPE USB to Ethernet Adapter (part number Q7Y55A).

When you use the iLO Service Port:

- Actions are logged in the iLO event log.
- The server UID flashes to indicate the Service Port status.

You can also retrieve the Service Port status by using a REST client and the iLO RESTful API.

- You cannot use the Service Port to boot any device within the server, or the server itself.
- You cannot access the server by connecting to the Service Port.
- You cannot access the connected device from the server.

For more information about the iLO Service Port, see the iLO user guide at the following website: <https://www.hpe.com/support/ilo6>.

Front panel LEDs and buttons

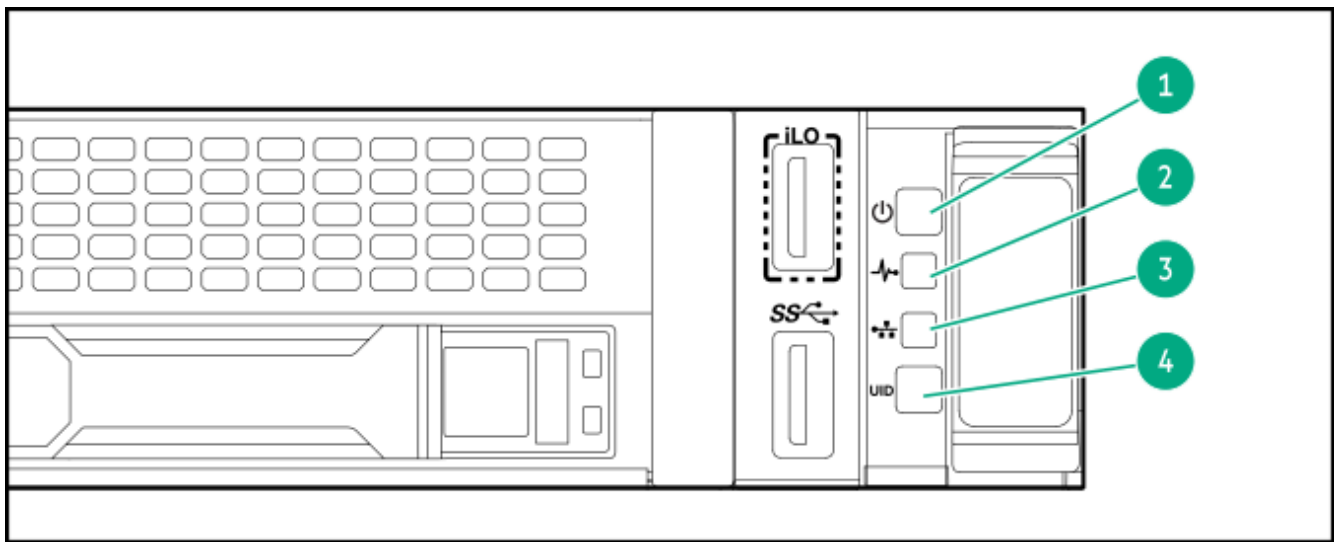

Item	Description	Status	Definition
1	Power On/Standby button and system power LED ¹ ₁	Solid green	System on
		Flashing green	Performing power-on sequence
		Solid amber	System in standby
		Off	No power present ² ₂
2	Health LED ¹ ₁	Solid green	Normal
		Flashing green	iLO is rebooting
		Flashing amber	System degraded ³ ₃
		Flashing red	System critical ³ ₃
3	NIC status LED ¹ ₁	Solid green	Linked to network
		Flashing green	Network active
		Off	No network activity
4	UID button/LED ¹ ₁	Solid blue	Activated

Item	Description	Status	Definition
		Flashing blue	<ul style="list-style-type: none"> • 1 flash per second—Remote management or firmware upgrade in progress • 4 flashes per second—iLO manual reboot sequence initiated • 8 flashes per second—iLO manual reboot sequence in progress
		Off	Deactivated

- ¹ When all LEDs flash simultaneously, a power fault has occurred. For more information, see [Front panel LED power fault codes](#).
- ² Facility power is not present, power cord is not attached, no power supplies are installed, or power supply failure has occurred.
- ³ If the health LED indicates a degraded or critical state, [review the system Integrated Management Log \(IML\) or use HPE iLO to review the system health status](#).

Subtopics

[Server UID LED](#)

[Viewing the Server Health Summary](#)

[Front panel LED power fault codes](#)

Server UID LED

The UID LED can be used to help an on-site technician quickly identify or locate a particular server when it is deployed in a dense rack with other equipment. It can also be used to identify if a remote management, firmware upgrade, or reboot sequence is in progress.

Viewing the Server Health Summary

Prerequisites

- An external monitor is connected.
- In the iLO web interface, the **Show Server Health on External Monitor** feature is enabled on the **Access Settings** page.

About this task

If the server does not power on, use the UID button to display the iLO **Server Health Summary** screen on an external monitor. This function works when the server is powered on or off.

For more information, see the iLO troubleshooting guide on the [Hewlett Packard Enterprise website](#).

Procedure

1. Press and release the UID button.



CAUTION

Be sure to press and release the UID button. Pressing the UID button at any time for more than five seconds will initiate a graceful iLO reboot or a hardware iLO reboot. Data loss or NVRAM corruption might occur during a hardware iLO reboot.

The **Server Health Summary** screen displays on the external monitor.

2. Press the UID button again to close the **Server Health Summary** screen.

Front panel LED power fault codes

The following table provides a list of power fault codes, and the subsystems that are affected. Not all power faults are used by all servers.

Subsystem	LED behavior
System board	1 flash
Processor	2 flashes
Memory	3 flashes
Riser board PCIe slots	4 flashes
FlexibleLOM	5 flashes
Storage controller	6 flashes
System board PCIe slots	7 flashes
Power backplane	8 flashes
Storage backplane	9 flashes
Power supply	10 flashes
PCIe expansion cards installed in riser board	11 flashes

Subsystem	LED behavior
Chassis	12 flashes
GPU card	13 flashes

Rear panel components

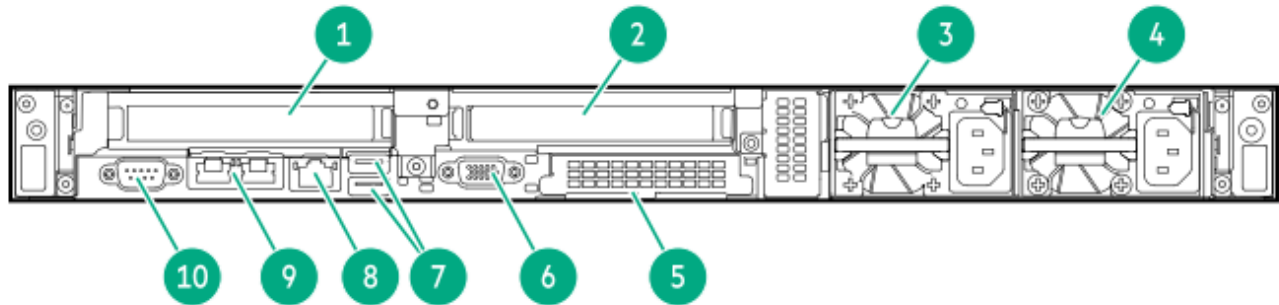

Item	Description
1	Slot 1 PCIe5 x16 (16, 8, 4, 2 (Gen4))
2	Slot 2 PCIe5 x16 (16, 8, 4, 2 (Gen4))
3	Power supply 2 (PS2)
4	Power supply 1 (PS1)
5	Slot 14 OCP PCIe5 x16
6	Video (VGA) port
7	USB 3.2 Gen1 ports
8	iLO Management Port
9	Embedded 1x2 network port
10	Serial port (optional)

Subtopics

Monitor setup

Monitor setup

Before connecting a monitor, observe the following:

- The server supports both VGA port and DisplayPort 1.1a.
- If you connect two display devices to the server using both the VGA port and DisplayPort, the same image is mirrored on both devices.
- The embedded video controller in the iLO chipset does not support dual display or screen extension mode. To enable dual display, install a compatible graphics card.
- When using HDMI or DVI adapters for the DisplayPort, use an active-type adapter. Passive-type adapters marked with the DP++ symbol are not supported.
- Whenever possible, use the same display connection type. For example, if your monitor only has a VGA port, use the VGA port on the server. Using other adapters or converter cables or dongles might lead to decreased display quality or a lag over the connection.

Rear panel LEDs

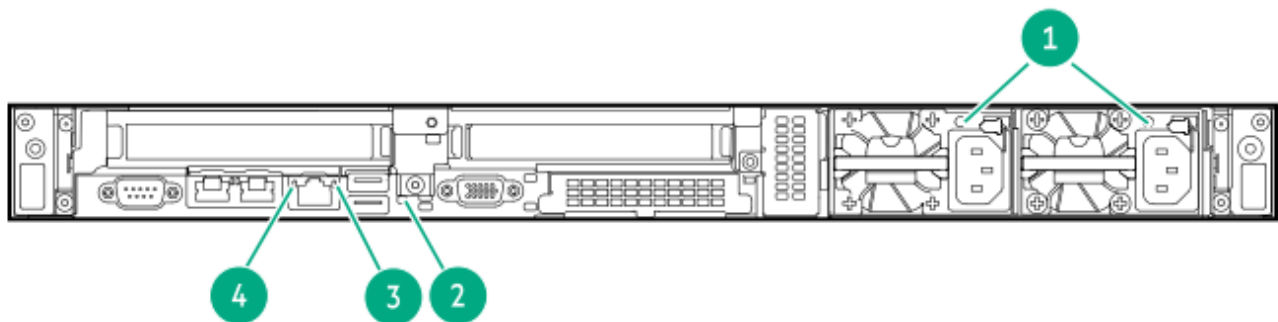

Item	LED	Status	Definition
1	Power supply	Solid green	The power supply is operating normally.
		Off	One or more of the following conditions exists: <ul style="list-style-type: none">• Power is unavailable• Power supply failure• Power supply is in standby mode• Power supply error

Item	LED	Status	Definition
2	UID	Solid blue	Activated
		Flashing blue	<ul style="list-style-type: none"> 1 flash per sec—Remote management or firmware upgrade in progress 4 flashes per sec—iLO manual reboot sequence initiated 8 flashes per sec—iLO manual reboot sequence in progress
		Off	Deactivated
3	iLO status	Solid green	Linked to network
		Flashing green	Network active
		Off	No network activity
4	iLO link	Solid green	Network link
		Off	No network link

Component touchpoints

Certain components are color-coded. These colors represent the recommended touch areas for a removal process and indicate whether components require a system shutdown before removal.

The following diagrams are examples only.

HPE hot-plug red

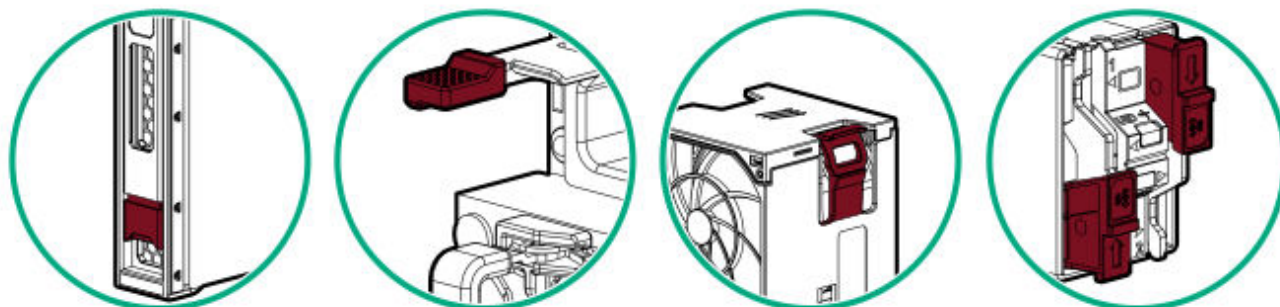

Hot-plug red indicates hot-pluggable components. These components can be removed and installed while the system is running, and doing so will not result in a system shutdown.

Component examples:

- Power supplies in a redundant power configuration
- Hot-plug fans
- Hot-plug drives
- M.2 SSDs in a hot-plug boot device

HPE touchpoint blue

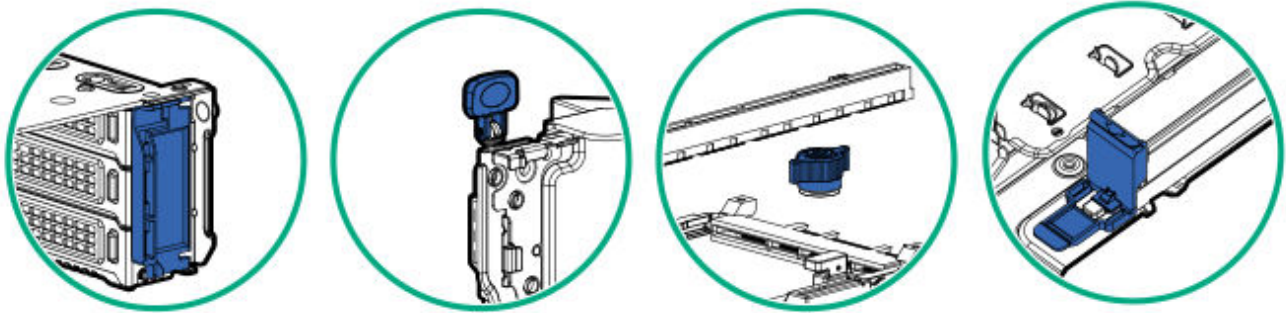

Touchpoint blue indicates cold-pluggable components. These components require a system shutdown. Failure to do so might result in system failure or data loss. Cold-pluggable components might also indicate touchpoints on non-electrical components.

Component examples:

- Storage devices
- Fan cages
- System boards
- Energy packs

System board components

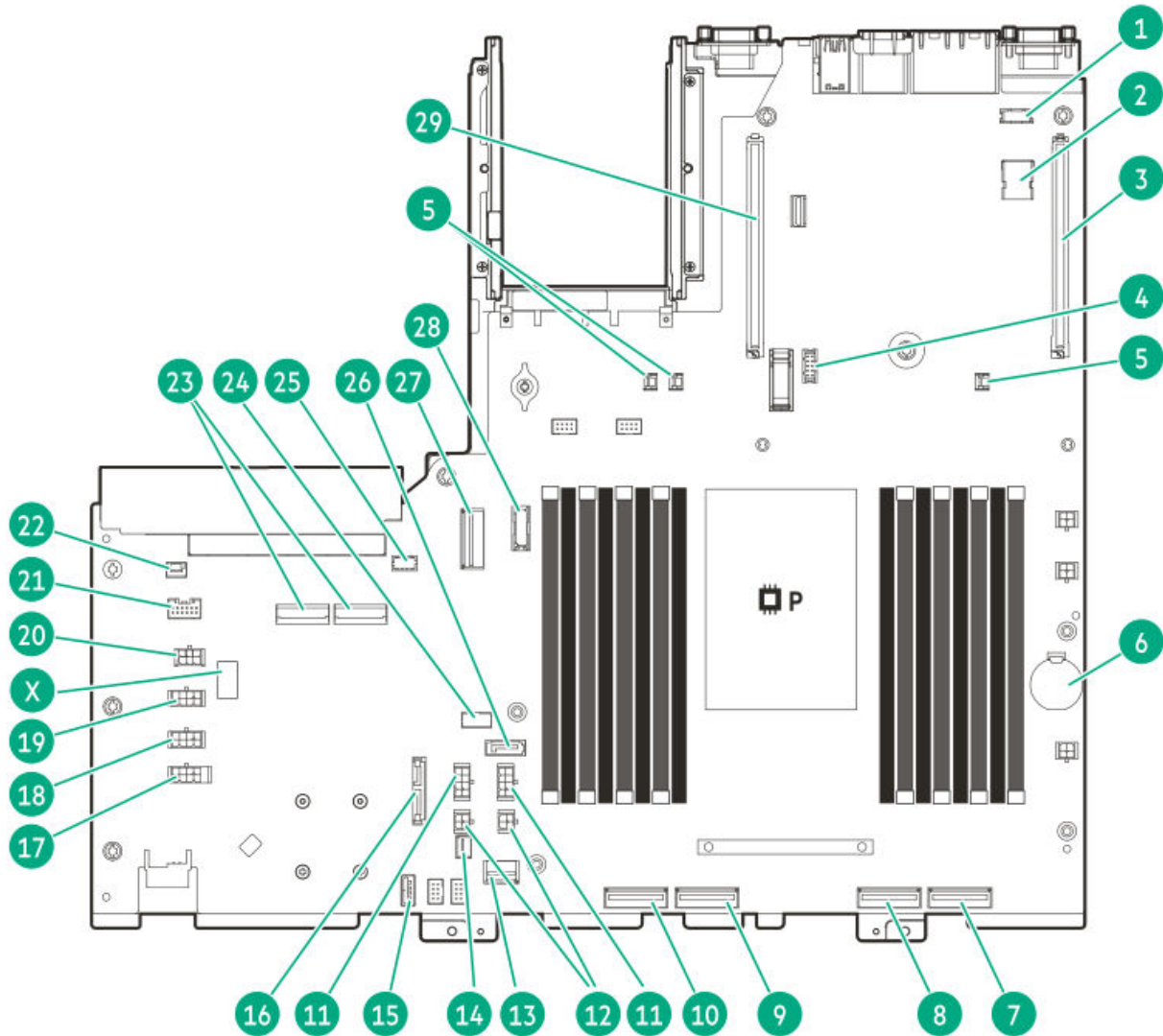

Item	Description
1	Serial port cable connector
2	Internal USB 2.0 port
3	Primary riser connector
4	Video (VGA) cable connector
5	Storage controller backup power connector
6	System battery
7	MCIO port 1

Item	Description
8	MCIO port 2
9	MCIO port 3
10	MCIO port 4
11	GPU Auxiliary power connector
12	GPU riser power connector ¹ _—
13	Front I/O connector
14	SATA sideband connector
15	Internal USB 3.2 Gen1 port
16	Optical drive connector
17	Drive box 5 power connector
18	Drive box 3 power connector
19	Drive box 1 power connector
20	Media bay power connector
21	Energy pack connector
22	Chassis Intrusion Detection connector
23	M.2 module connectors
24	Switch board sideband connector ¹ _—
25	NS204i-u power connector
26	SATA 6 Gb/s port
27	x8 slimSAS port 1
28	Display port cable connector
29	Secondary riser connector
X	<u>System maintenance switch</u>

¹_— This component is used in the 4 SFF and 8 E3.S drive configurations.

Subtopics

System maintenance switch

DIMM label identification

DIMM slot numbering

Heatsink and processor socket components

System maintenance switch

The system maintenance switch is a DIP switch block on the system board used during service and troubleshooting to temporarily override security or configuration settings. Each switch has an OFF (default) and ON position that enables a specific maintenance function.

To locate the system maintenance switch on your server, see [System board components](#).

Position	Default	Function
S1 ¹ _—	Off	<ul style="list-style-type: none">Off—iLO 6 security is enabled.On—iLO 6 security is disabled.
S2	Off	Reserved
S3	Off	Reserved
S4	Off	Reserved
S5 ¹ _—	Off	<ul style="list-style-type: none">Off—Power-on password is enabled.On—Power-on password is disabled.
S6 ^{1, 2, 3} _—	Off	<ul style="list-style-type: none">Off—No functionOn—Restore default manufacturing settings
S7	Off	Reserved
S8	Off	Reserved
S9	Off	Reserved
S10	Off	Reserved
S11	Off	Reserved
S12	Off	Reserved

¹ To access the redundant ROM, set S1, S5, and S6 to On.

² When the system maintenance switch position 6 is set to the On position, the system is prepared to restore all configuration settings to their manufacturing defaults.

³ When the system maintenance switch position 6 is set to the On position and Secure Boot is enabled, some configurations cannot be restored. For more information, see [Configuring the server](#).

DIMM label identification

The label contains information about the DIMM. For additional information about DIMMs, including:

- Memory speeds and server-specific DIMM population rules
- Product features, specifications, options, configurations, and compatibility

See the website:

<https://www.hpe.com/docs/server-memory>

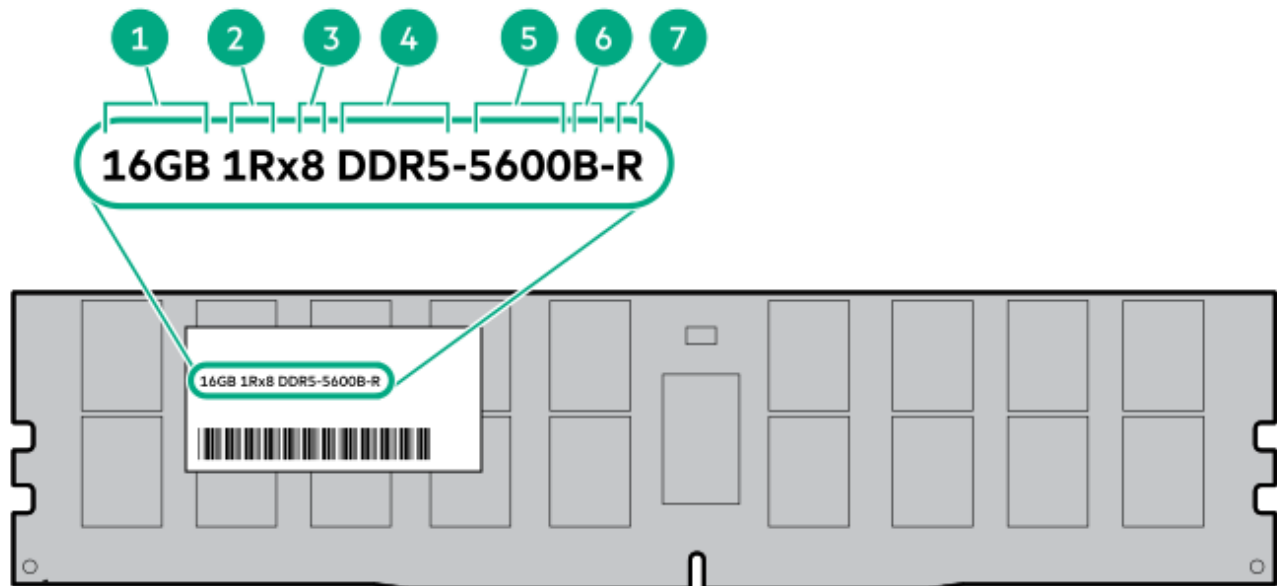

Item	Description	Example
1	Capacity $\frac{1}{_}$	16 GB 32 GB 64 GB 96 GB 128 GB 256 GB
2	Rank	1R—Single rank 2R—Dual rank 4R—Quad rank 8R—Octal rank

Item	Description	Example
3	Data width on DRAM	x4—4-bit x8—8-bit
4	Memory generation	PC5—DDR5
5	Maximum memory speed ¹ / _—	4800 MT/s 5600 MT/s 6400 MT/s
6	CAS latency	B—42-42-42 B—50-42-42 (for 128 GB and 256 GB capacities)
7	DIMM type	E—UDIMM (unbuffered with ECC) R—RDIMM (registered)

¹/_— The maximum memory speed and capacity is a function of the memory type, memory configuration, and processor model.

DIMM slot numbering

The arrow points to the front of the server.

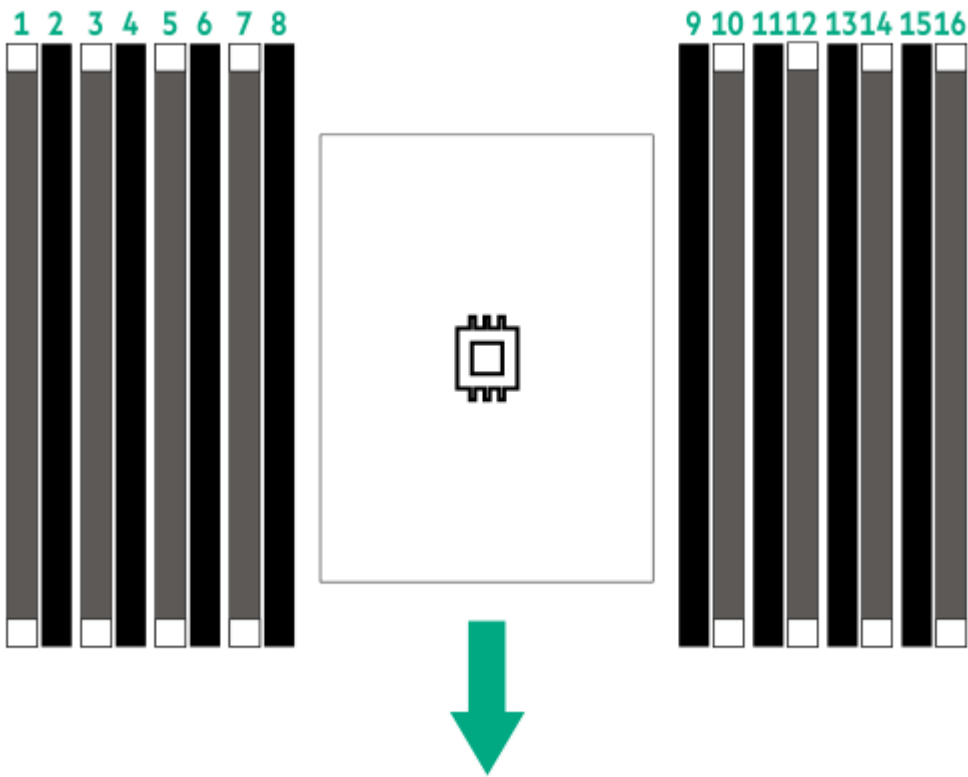

Heatsink and processor socket components

A standard heatsink is shown. Your heatsink might look different.

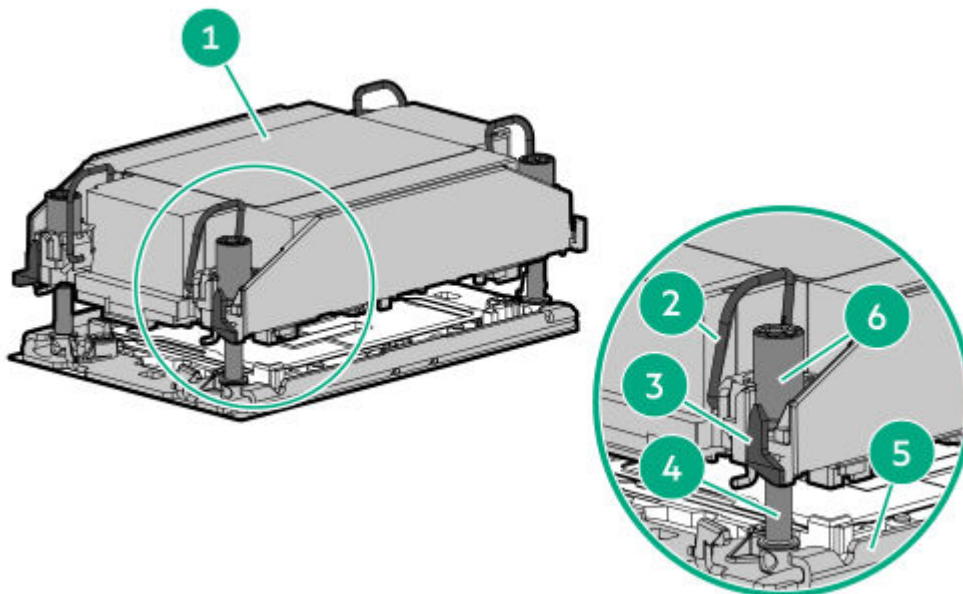

Item	Description
1	Processor-heatsink module *
2	Anti-tilt wires
3	Processor carrier release tabs
4	Bolster plate guide posts
5	Bolster plate
6	Heatsink screws

* This module consists of the heatsink attached to the processor that is already secured in its carrier.

Riser board components

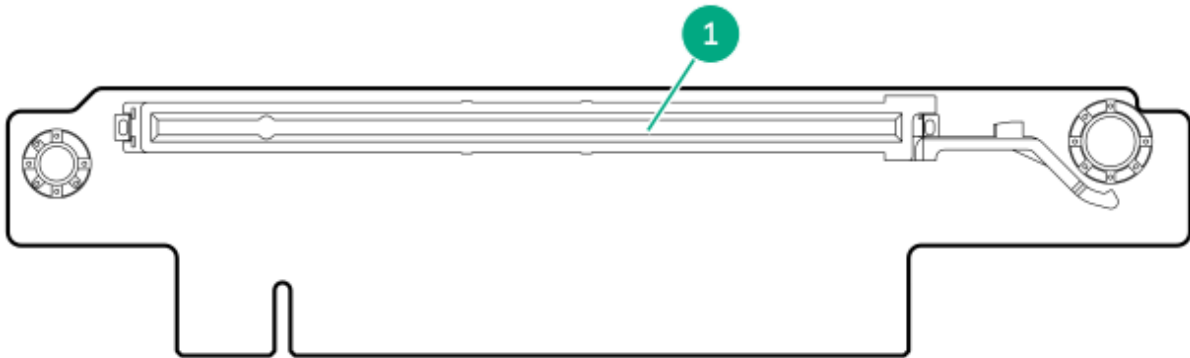

Item	Description	Supported form factors
1	PCIe5 x16 (16, 8, 4, 2 (Gen4))	<ul style="list-style-type: none"> • Full-height, half-length • Half-height, half-length (low-profile)

GPU riser board

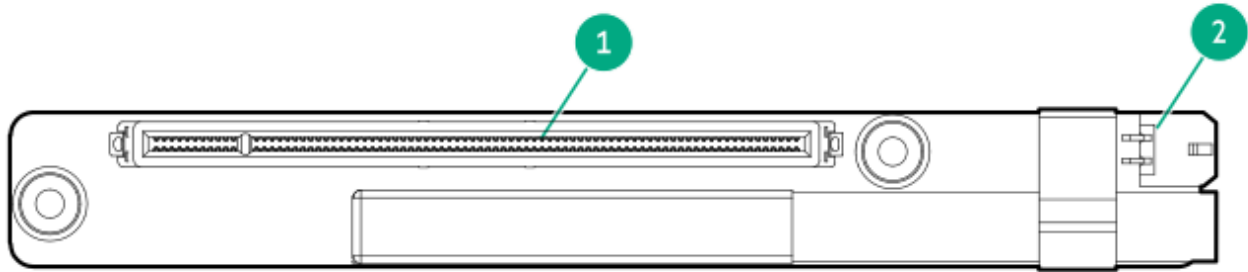

Item	Description	Supported form factors
1	PCIe5 x16 (16, 8, 4, 2 (Gen4))	<ul style="list-style-type: none"> • Full-height, full-length • Half-height, half-length (low-profile)
2	Power connector	–

PCIe5 slot description

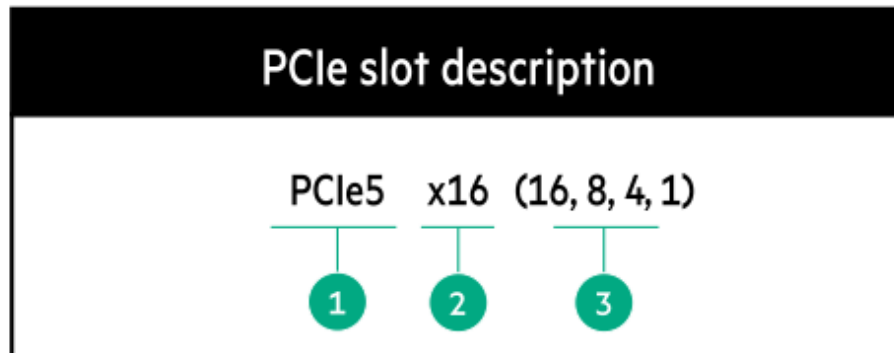

Item	Description	Definition
1	PCI Express version	<p>Each PCIe version corresponds to a specific data transfer rate between the processor and peripheral devices. Generally, a version update corresponds to an increase in transfer rate.</p> <ul style="list-style-type: none"> • PCIe 1.x

Item	Description	Definition
		<ul style="list-style-type: none"> • PCIe 2.x • PCIe 3.x • PCIe 4.x • PCIe 5.x <p>The PCIe technology is under constant development. For the latest information, see the PCI-SIG website.</p>
2	Physical connector link width	<p>PCIe devices communicate through a logical connection called an interconnect or link. At the physical level, a link is composed of one or more lanes. The number of lanes is written with an x prefix with x16 being the largest size in common use.</p> <ul style="list-style-type: none"> • x1 • x2 • x4 • x8 • x16
3	Negotiable link width	<p>These numbers correspond to the maximum link bandwidth supported by the slot.</p>

PCIe switch board components

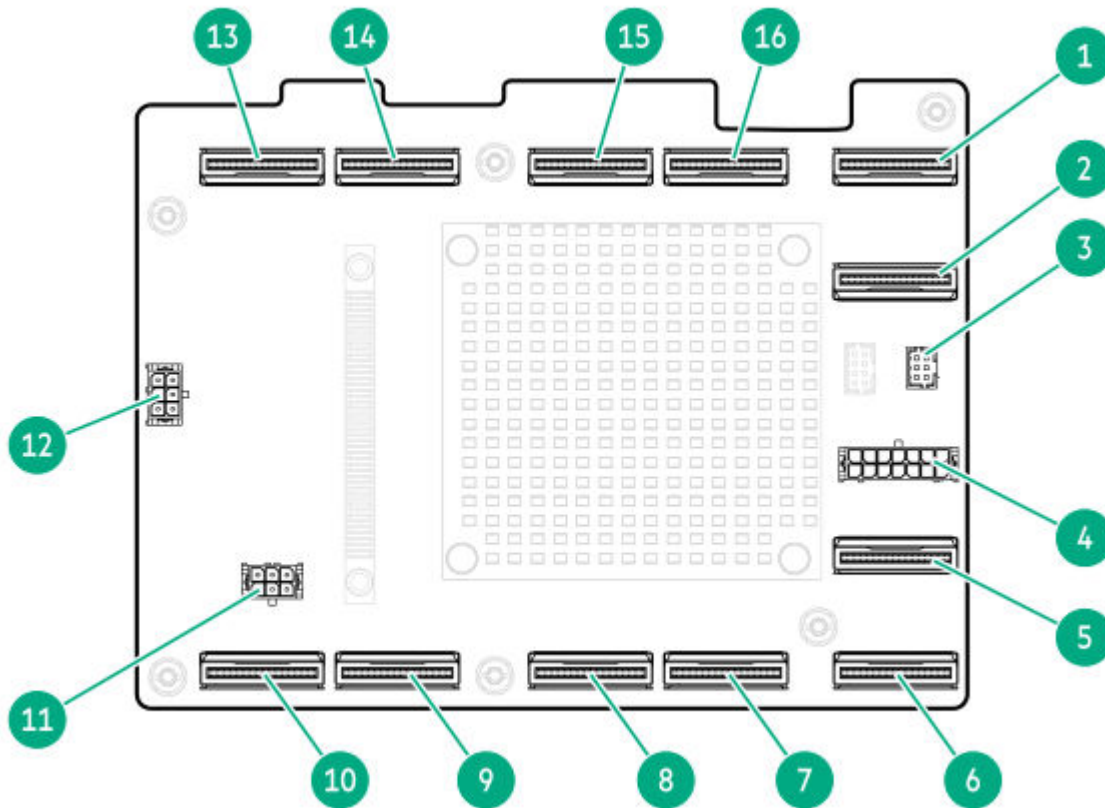

Item	Description	Connect to
1	Switch board downstream port 1	MCIO port 4
2	Switch board downstream port 2	MCIO port 3
3	Switch board signal extension connector	Switch board sideband connector
4	Switch board power connector	Drive box 5 power connector and Drive box 3 power connector
5	Switch board downstream port 3	MCIO port 2
6	Switch board downstream port 4	MCIO port 1
7	GPU riser slot 5 MCIO connector (SEC)	GPU riser slot 5
8	GPU riser slot 5 MCIO connector (PRIM)	
9	GPU riser slot 6 MCIO connector (SEC)	GPU riser slot 6

Item	Description	Connect to
10	GPU riser slot 6 MCIO connector (PRIM)	
11	GPU riser slot 5 and 6 power connector	GPU riser slot 6 (P2) GPU riser slot 5 (P3)
12	GPU riser slot 3 and 4 power connector	GPU riser slot 3 (P2) GPU riser slot 4 (P3)
13	GPU riser slot 4 MCIO connector (SEC)	GPU riser slot 4
14	GPU riser slot 4 MCIO connector (PRIM)	
15	GPU riser slot 3 MCIO connector (SEC)	GPU riser slot 3
16	GPU riser slot 3 MCIO connector (PRIM)	

Accelerator slot numbering

Rear riser cage configuration



Single-width GPU configuration

- 1 single-width accelerator with 4 SFF NVMe drive configuration
- 1 single-width accelerator with 8 E3.S drive configuration



- 2 single-width accelerators with 4 SFF NVMe drive configuration
- 2 single-width accelerators with 8 E3.S drive configuration



- 4 single-width accelerators with 4 SFF NVMe drive configuration
- 4 single-width accelerators with 8 E3.S drive configuration



Double-width GPU configuration

- 1 double-width accelerator with 4 SFF NVMe drive configuration
- 1 double-width accelerator with 8 E3.S drive configuration

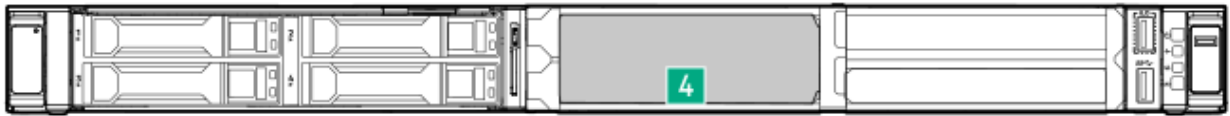

- 2 double-width accelerators with 4 SFF NVMe drive configuration
- 2 double-width accelerators with 8 E3.S drive configuration



HPE Basic Drive LED definitions

The HPE Basic drive carrier has the following LEDs:

- Amber/blue LED—Managed by the drive backplane in conjunction with the storage controller and is used to indicate drive status.

- Green LED—Managed by the drive itself and indicates the drive activity.

LFF low-profile drive carrier

The LFF low-profile drive carrier supports hot-plug hot-plug, SAS, and SATA.

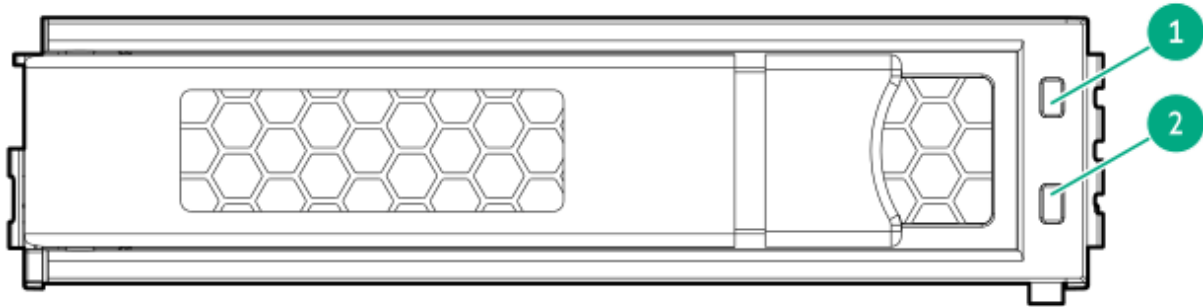

SFF basic drive carrier

The SFF basic drive carrier supports hot-plug SAS, SATA, NVMe.

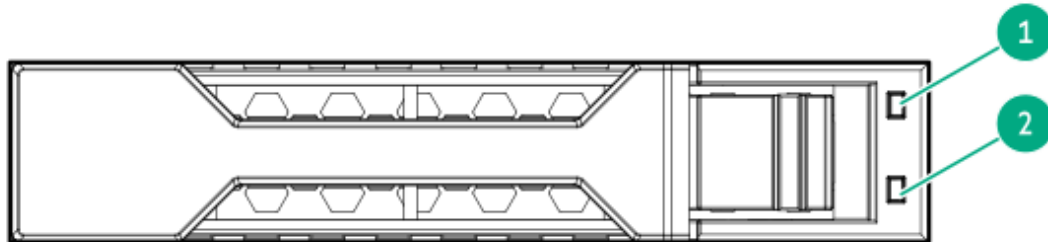

Item	LED	State	Definition
1	Fault/Locate	Solid amber	This drive has failed, is unsupported, or is invalid.
		Solid blue	The drive is operating normally and being identified by a management application.
		Flashing amber/blue (1 flash per second)	The drive has failed, or a predictive failure alert has been received for this drive. The drive has also been identified by a management application.

Item	LED	State	Definition
		Flashing amber (1 flash per second)	A predictive failure alert has been received for this drive. Replace the drive as soon as possible.
		Off	The drive is operating normally and not being identified by a management application.
2	Online/Activity	Solid green	The drive is online and has no activity.
		Flashing green (1 flash per second)	The drive is doing one of the following: <ul style="list-style-type: none"> • Rebuilding or performing a RAID • Performing a stripe size migration • Performing a capacity expansion • Performing a logical drive extension • Erasing • Spare part activation
		Flashing green (4 flashes per second)	The drive is operating normally and has activity.
		Off	The drive is not configured by a RAID controller or is a spare drive.

EDSFF SSD LED definitions

The EDSFF drive carrier has two LEDs:

- Amber/blue LED—Managed by the drive backplane in conjunction with the storage controller and is used to indicate drive status.
- Green LED—Managed by the drive itself and indicates the drive activity.



Item	LED	State	Definition
1	Fault/Locate	Solid amber	This drive has failed, is unsupported, or is invalid.
		Solid blue	The drive is operating normally and being identified by a management application.
		Flashing amber/blue (1 flash per second)	The drive has failed, or a predictive failure alert has been received for this drive. The drive has also been identified by a management application.
		Flashing amber (1 flash per second)	A predictive failure alert has been received for this drive. Replace the drive as soon as possible.
		Off	The drive is operating normally and not being identified by a management application.
2	Online/Activity	Solid green	The drive is online and has no activity.
		Flashing green (4 flashes per second)	The drive is operating normally and has activity.
		Off	No power present.

Drive box identification

- LFF drive model
 - Short chassis

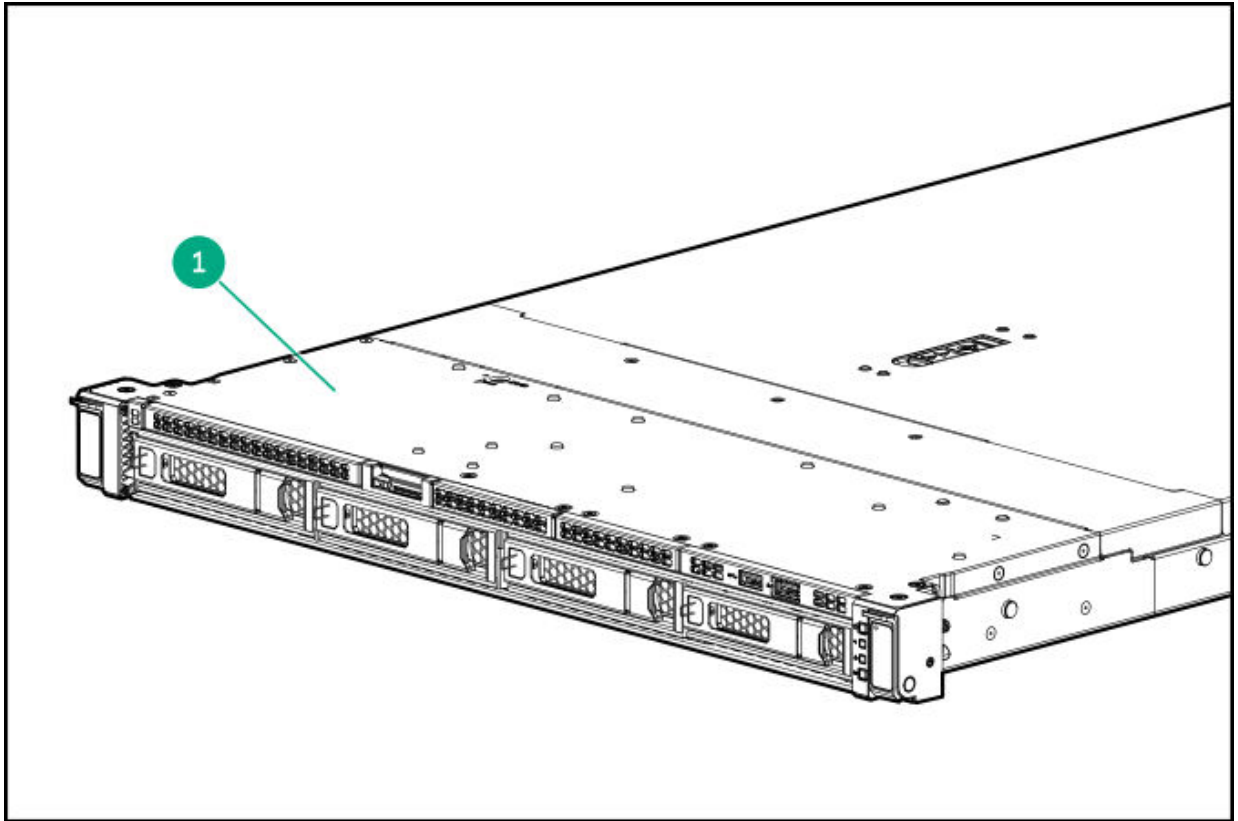

- Long chassis

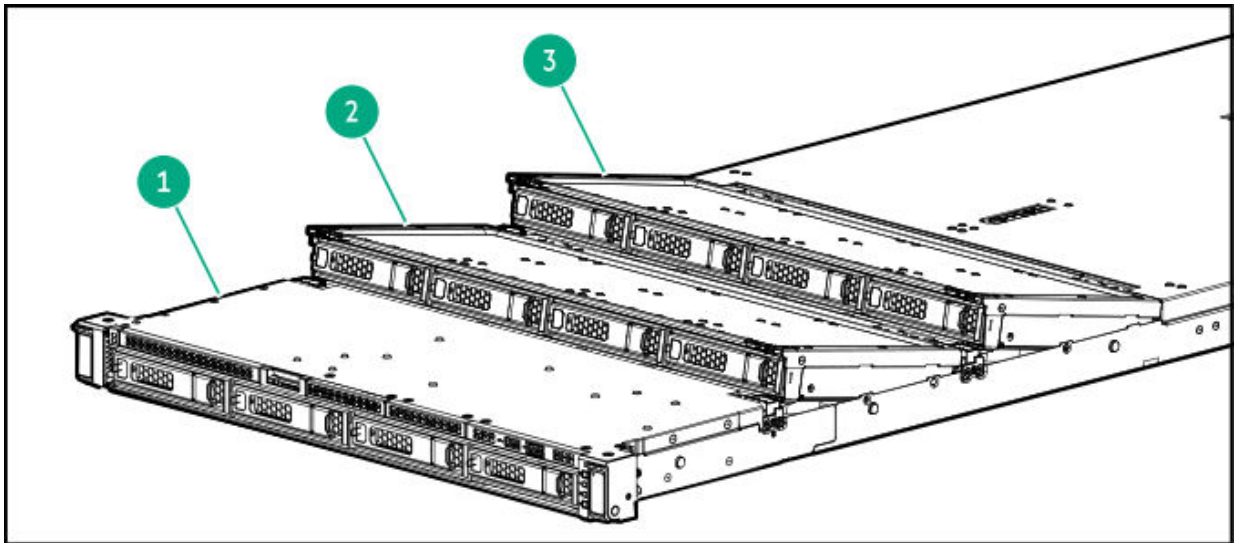

- SFF drive model

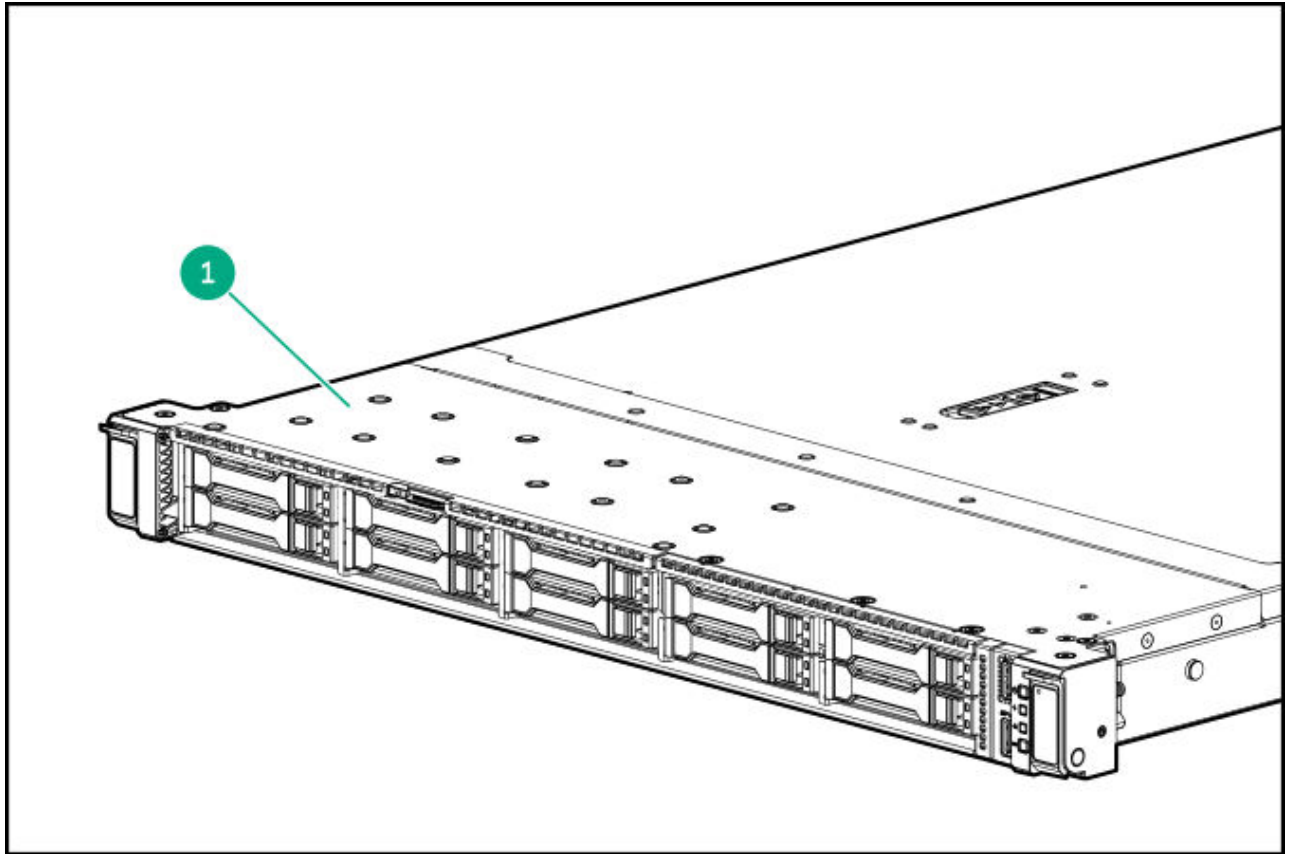

Item	Description
1	Box 1
2	Box 3
3	Box 5

Drive bay numbering



CAUTION

When a server is purchased without any drive installed, some drive bays might be empty while other drive bays might be populated with drive blanks. To maintain proper system cooling, do not operate the server without a drive or a drive blank installed.

Subtopics

SFF drive bay numbering

LFF drive bay numbering

E3.S drive bay numbering

SFF drive bay numbering

The following drive backplane options are supported in all SFF drive configurations:

- 2 SFF side-by-side drive backplanes:
 - 2 SFF 24G x4 NVMe / SAS UBM3 BC
 - 2 SFF 24G x4 NVMe / SAS UBM6 BC
- 8 SFF drive backplanes:
 - 8 SFF 24G x 1 NVMe / SAS UBM3 BC
 - 8 SFF 24G x1 NVMe / SAS UBM6 BC
 - 8 SFF 24G x4 NVMe / SAS UBM3 BC
 - 8 SFF 24G x4 NVMe / SAS UBM6 BC

The following drive backplane options are supported in servers with a GPU riser cage:

- 4 SFF drive backplanes:
 - 2x 2SFF 24G x4 NVMe / SAS UBM3 BC
 - 2x 2SFF 24G x4 NVMe / SAS UBM6 BC

For more information on the drive backplane description, see [Drive backplane naming](#).

8 SFF drive bay numbering

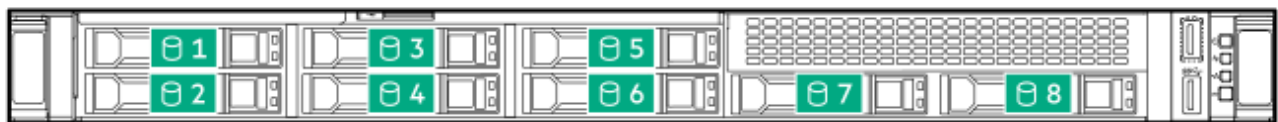

8 + 2 SFF drive bay numbering

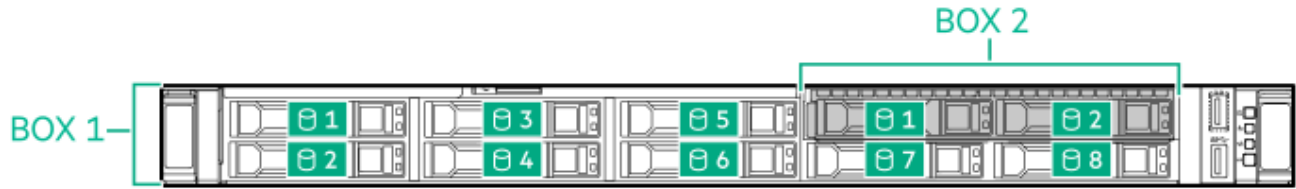

Box	Drive bays
1	1–8
2	1 and 2

4 SFF drive bay numbering



Box	Drive bays
1	1 and 2
2	1 and 2

In the SFF drive configuration:

- Drives are assigned to box 1 and optional box 2.
- SAS, SATA, NVMe are supported.
- To manage the hot-plug SAS drive, install one of the following storage controllers:
 - HPE SR/MR type-p Gen11 storage controller
 - HPE MR type-o Gen11 storage controller (OROC)
- When installing NVMe drives, install either all U.2 or all U.3 drives. Mixed NVMe drive type installation in the same box is not supported.

LFF drive bay numbering

The following drive backplane options are supported in all LFF drive configurations:

- 4 LFF 12G x1 SAS UBM2 LP
- 4 LFF 12G x1 SAS UBM6 LP

For more information on the drive backplane description, see [Drive backplane naming](#).

4 LFF drive bay numbering

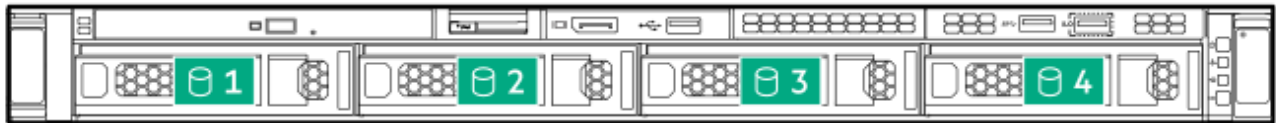

12 LFF drive bay numbering

- Box 1

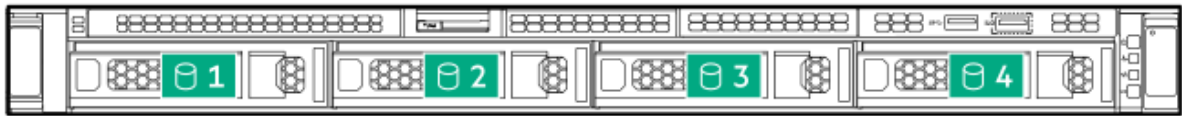

- Box 3/Box 5

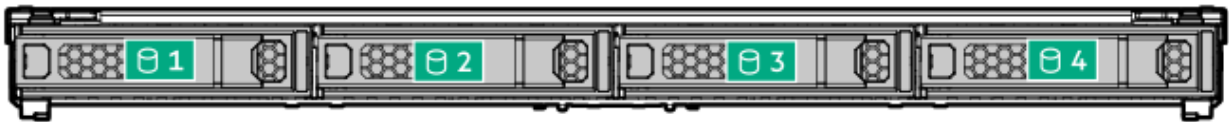

In the LFF drive configuration:

- All drives belong to box 1.
- hot-plug, SAS, and SATA drives are supported.
- To manage the hot-plug SAS drive, install the HPE MR type-o Gen11 storage controller (OROC).

E3.S drive bay numbering

The 8 E3.S 32G x4 NVMe UBM5 E3C drive backplane option is supported.

For more information on the drive backplane description, see [Drive backplane naming](#).



Drive backplane naming

This topic explains the features represented in the drive backplane naming. This naming convention was adopted starting in the HPE Gen11 server release. Your server might not support all the features listed in this topic. For server-specific support information, see the server guides:

- Drive backplane support, see [Drive bay numbering](#).
- Drive backplane cabling, see [Storage cabling](#).



Item	Description	Values
1	Drive bay count	Number of drive bays supported by the backplane.
2	Drive form factor	LFF—Large Form Factor SFF—Small Form Factor E3S—Enterprise and Datacenter Standard Form Factor (EDSFF E3.S)
3	Maximum link rate per lane (GT/s)	12G 16G

Item	Description	Values
		24G
		32G
4	Port link width and interface	x1 NVMe/SAS—U.3 NVMe, SAS, or SATA ¹ x4 NVMe/SAS—U.3 NVMe, SAS, or SATA ² x4 NVMe—NVMe ³ x4 NVMe—E3.S
5	Universal backplane manager (UBM) model	The UBM model defines the UBM firmware used by the backplane. Examples of UBM models: UBM2, UBM3, and etc.
6	Drive carrier type	BC—Basic carrier (SFF) LP—Low-profile carrier (LFF) EC—E3.S carrier

¹ Tri-mode controller support for x1 U.3 NVMe, SAS, and SATA drives. System board connection supports SATA drives only.

² CPU direct attach or tri-mode controller support for x4 U.3 NVMe, x2 (via a splitter cable) U.3 NVMe, or x1 SAS and SATA drives.

³ CPU direct attach or tri-mode controller support for x4 NVMe drives.

Fan numbering

To provide sufficient airflow to the system, the server is by default populated by five standard fans or seven high performance fans. There are a total of seven fans.

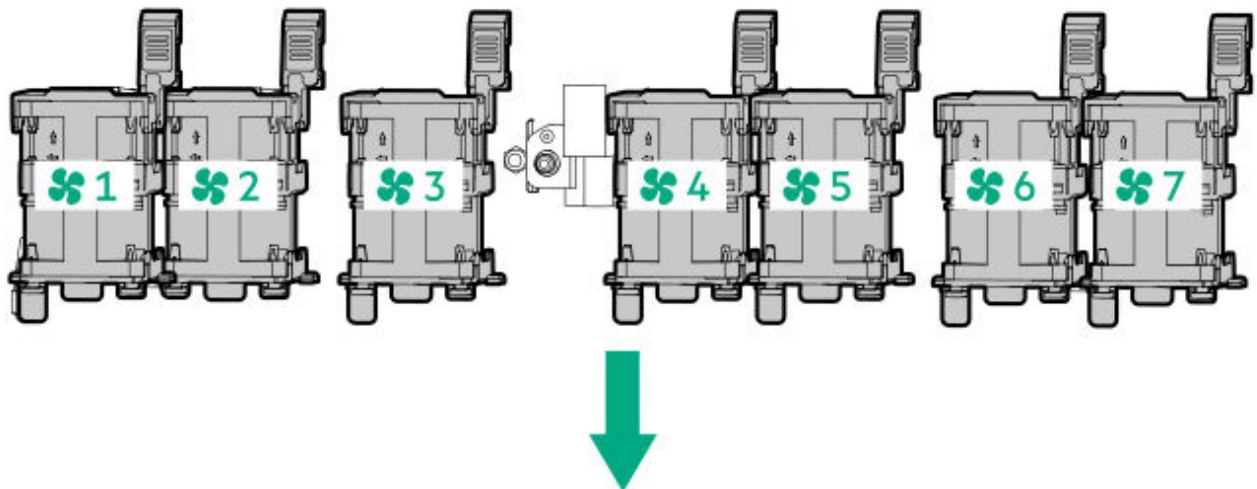

The arrow points to the front of the server.

Fan and heatsink requirements

The table lists the fan and heatsink requirements for the server depending on the hardware configuration. For more detailed information, see the product QuickSpecs on the Hewlett Packard Enterprise website (<https://www.hpe.com/info/quickspecs>).

Configuration	Fan	Processor TDP	Ambient operating temperature	Heatsink
8 + 2 SFF drives	Standard	$\leq 185\text{ W}$	30°C (86°F)	Standard
	High performance	185 W < CPUs with TDP $\leq 270\text{ W}$		Performance
4 LFF drives	Standard	$\leq 185\text{ W}$	30°C (86°F)	Standard
	High performance	185 W < CPUs with TDP $\leq 270\text{ W}$		Performance
12 LFF drives	High performance	$\leq 185\text{ W}$	30°C (86°F)	Standard
		185 W < CPUs with TDP $\leq 270\text{ W}$		Performance
2 dual width GPU	High performance	185 W < CPUs with TDP $\leq 270\text{ W}$	$\leq 25^\circ\text{C}$ (77°F)	Performance
		CPUs with TDP $\leq 185\text{ W}$		Standard
2 single width GPU	High performance	185 W < CPUs with TDP $\leq 270\text{ W}$	$\leq 25^\circ\text{C}$ (77°F)	Performance
		CPUs with TDP $\leq 185\text{ W}$		Standard

Trusted Platform Module 2.0

The Trusted Platform Module 2.0 (TPM) is a hardware-based system security feature that securely stores artifacts used to authenticate the platform. These artifacts can include passwords, certificates, and encryption keys.

The TPM 2.0 is embedded on the server system board.

The TPM 2.0 is supported with specific operating system support such as Microsoft Windows Server 2012 R2 and later. For more information about operating system support, see the product QuickSpecs on the Hewlett Packard Enterprise website (<https://www.hpe.com/info/quickspecs>). For more information

about Microsoft Windows BitLocker Drive Encryption feature, see the Microsoft website (<https://www.microsoft.com>).

Subtopics

[Trusted Platform Module 2.0 guidelines](#)

[BitLocker recovery key/password retention guidelines](#)

Trusted Platform Module 2.0 guidelines



CAUTION

- Always observe the TPM guidelines in this section. Failure to follow these guidelines can cause hardware damage or halt data access.
- If you do not follow procedures for modifying the server and suspending or disabling the TPM in the OS, an OS that is using TPM might lock all data access. This includes updating system or option firmware, replacing hardware such as the system board and drives, and modifying TPM OS settings.
- Changing the TPM mode after installing an OS might cause problems, including loss of data.

- Use the UEFI System Utilities to configure the TPM. From the **System Utilities** screen, select **System Configuration** > **BIOS/Platform Configuration (RBSU)** > **Server Security** > **Trusted Platform Module options**. For more information, see the UEFI user guide:

<https://www.hpe.com/support/hpeuefisytemutilities-quicklinks>

- When using the Microsoft Windows BitLocker Drive Encryption feature, always retain the recovery key or password. The recovery key or password is required to enter Recovery Mode after BitLocker detects a possible compromise of system integrity.
- HPE is not liable for blocked data access caused by improper TPM use. For operating instructions, see the documentation for the encryption technology feature provided by the operating system.

BitLocker recovery key/password retention guidelines

The recovery key/password is generated during BitLocker setup, and can be saved and printed after BitLocker is enabled. When using BitLocker, always retain the recovery key/password. The recovery key/

password is required to enter Recovery Mode after BitLocker detects a possible compromise of system integrity.

To help ensure maximum security, observe the following guidelines when retaining the recovery key/ password:

- Always store the recovery key/password in multiple locations.
- Always store copies of the recovery key/password away from the server.
- Do not save the recovery key/password on an encrypted drive.

HPE NS204i-u Boot Device components

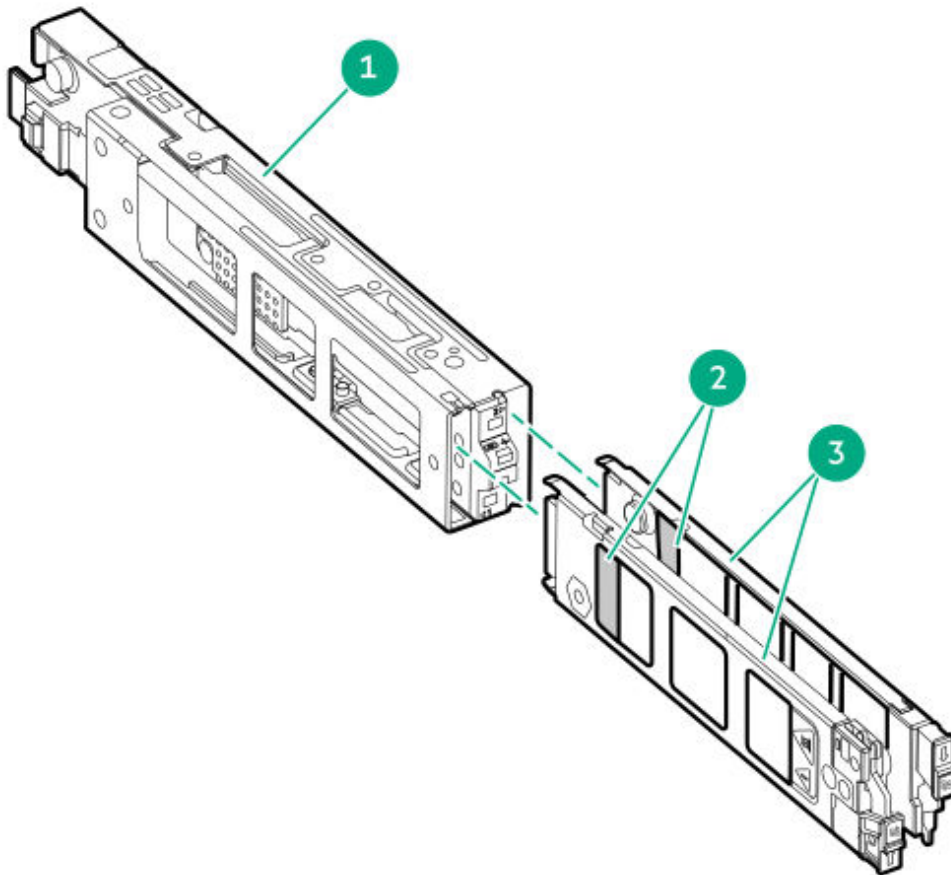

Item	Description
1	Boot device cage
2	M.2 slots

Item	Description
3	Boot device carriers

HPE NS204i-u Boot Device LED definitions

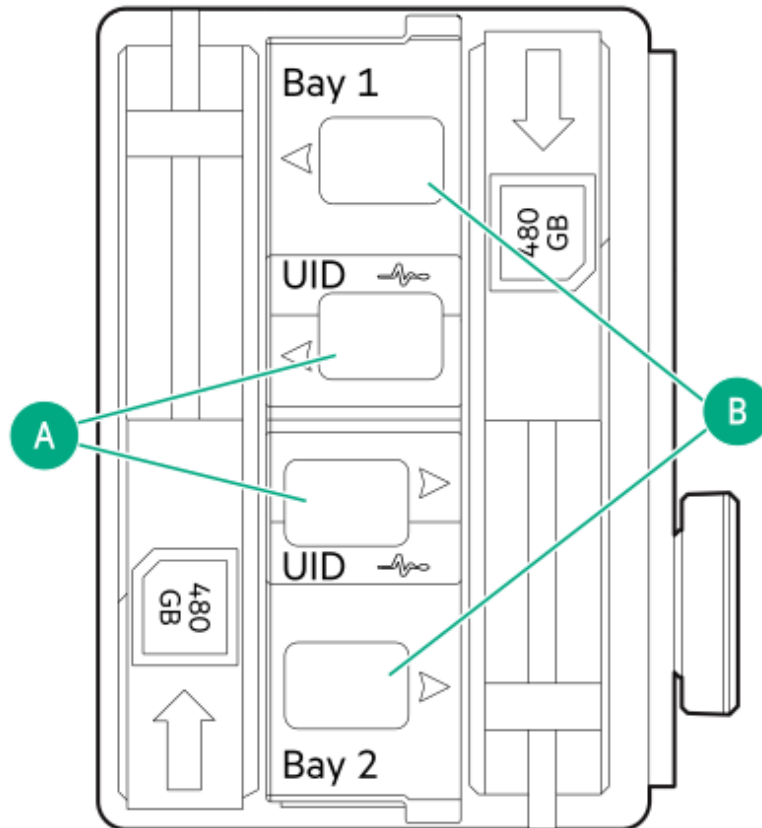

NOTE

The bay number can be found on the SSD carrier handle.

Item	LED	Status	Definition
A	Fault or Locate	Solid amber	Drive has failed, unsupported, or invalid.
		Solid blue	Drive is operating normally.
		Flashing amber or blue (one flash per second)	Drive has failed, or a predictive failure alert is received for the drive.

Item	LED	Status	Definition
		Flashing amber (one flash per second)	Drive predictive failure alert is received. Replace the drive as soon as possible.
		Off	Drive is operating normally and is not identified by any application.
B	Online/Activity	Solid green	Drive is online and has no activity.
		Flashing green (one flash per second)	Drive is doing one of the following: <ul style="list-style-type: none"> • Rebuilding or performing a RAID • Erasing
		Flashing green (4 flashes per second)	Drive is operating normally and has activity.
		Off	Drive is not configured by a RAID controller.

Setup

This chapter describes general operational requirements and safety reminders, as well as the initial setup procedure for the server.

Subtopics

[Initial system installation](#)

[Operational requirements](#)

[Rack warnings and cautions](#)

[Server warnings and cautions](#)

[Electrostatic discharge](#)

Initial system installation

Depending on your technical expertise and the complexity of the product, for the initial system installation, select one of the following options:

- [Ordering the HPE Installation Service](#)
- [Setting up the server](#)

Subtopics

[HPE Installation Service](#)

HPE Installation Service

HPE Installation Service provides basic installation of Hewlett Packard Enterprise branded equipment, software products, as well as HPE-supported products from other vendors that are sold by HPE or by HPE authorized resellers. The Installation Service is part of a suite of HPE deployment services that are designed to give users the peace of mind that comes from knowing that their HPE and HPE-supported products have been installed by an HPE specialist.

The HPE Installation Service provides the following benefits:

- Installation by an HPE authorized technical specialist.
- Verification prior to installation that all service prerequisites are met.
- Delivery of the service at a mutually scheduled time convenient to your organization.
- Allows your IT resources to stay focused on their core tasks and priorities.
- Full coverage during the warranty period for products that require installation by an HPE authorized technical specialist.

For more information on the features, limitations, provisions, and ordering information of the HPE Installation Service, see this Hewlett Packard Enterprise website:

<https://www.hpe.com/support/installation-service>

Intel VROC support

Intel Virtual RAID on CPU (Intel VROC) provides enterprise-level hybrid RAID support. Note the following information:

- Intel VROC provides RAID support for direct attached SATA and NVMe SSDs.
- The Intel VROC driver is required. For the OS-specific driver download, see the following page:

<https://www.hpe.com/support/VROC-installation>

- Intel VROC requires the server boot mode to be set to **UEFI Mode**.
- Intel VROC RAID support is disabled by default. In the pre-OS environment, use UEFI System Utilities to enable Intel VROC and create a VROC RAID volume. These tasks are not supported in Intelligent Provisioning.

- The VROC RAID volume must use drives of the same interface and form factor.
- Intel VROC supports RAID management through the following tools:
 - Non-OS specific: UEFI System Utilities
 - Windows: Intel VROC GUI, Intel VROC CLI
 - Linux: `mdadm` CLI

For more information on Intel VROC features and configuration, see [Configuring storage controllers](#).

Setting up the server

Prerequisites

- As a best practice, Hewlett Packard Enterprise recommends installing the latest firmware, drivers, and system software before using the server for the first time. You have these options:
 - HPE Compute Ops Management is an advanced software-as-a-service platform that securely streamlines operations from edge-to-cloud and automates key life cycle tasks through a unified single browser-based interface. For more information on using HPE Compute Ops Management, see <https://www.hpe.com/support/hpe-gl-com-quicklinks>.
 - Use the **Firmware Update** option in Intelligent Provisioning—Intelligent Provisioning is a server deployment tool embedded in HPE ProLiant servers. To access Intelligent Provisioning, during the server boot process, press **F10**. For more information, see the Intelligent Provisioning user guide at <https://www.hpe.com/support/hpeintelligentprovisioning-quicklinks>.
 - Download the Service Pack for ProLiant (SPP)—SPP is a comprehensive system software and firmware update solution that is delivered as a single ISO image. This solution uses Smart Update Manager (SUM) as the deployment tool.
 - The preferred method for downloading an SPP is by creating an SPP custom download at <https://www.hpe.com/servers/spp/custom>.
This option reduces the size of the SPP by excluding firmware and drivers for OS and server models that are not needed.
 - The SPP is also available for download from the SPP download page at <https://www.hpe.com/servers/spp/download>.
- Verify that your OS or virtualization software is supported: <https://www.hpe.com/support/Servers-Certification-Matrices>

- The embedded Intel Virtual RAID on CPU (Intel VROC) provides enterprise-level hybrid RAID support. Note the following information:
 - Intel VROC provides RAID support for direct attached SATA and NVMe SSDs, including M.2 SSDs.
 - The VROC RAID volume must use drives of the same form factor.
 - Intel VROC requires the server boot mode to be set to **UEFI Mode**.
 - In the pre-OS environment, use UEFI System Utilities to enable Intel VROC and create a VROC RAID volume. This task is not supported in Intelligent Provisioning.
 - Intel VROC supports RAID management through the following tools:
 - Non-OS specific: UEFI System Utilities
 - Windows: Intel VROC GUI, Intel VROC CLI
 - Linux: `mdadm` CLI

For more information on Intel VROC features and configuration, see the Intel Virtual RAID on CPU for HPE User Guide:

<https://hpe.com/support/VROC-Gen11-UG>.

- Read the [operational requirements](#) for the server.
- Read the safety and compliance information:

<https://www.hpe.com/support/safety-compliance-enterpriseproducts>
- Take note of the iLO hostname and default login credentials on the [serial number/ iLO information pull tab](#).

Procedure

1. Unbox the server and verify the contents:
 - Server
 - Power cord
 - Rack rail hook-and-loop strap
 - Rack-mounting hardware (optional)
 - Printed setup documentation

The server does not ship with OS media. All system software and firmware is preloaded on the server.

2. (Optional) [Install the hardware options](#).
3. [Install the server into the rack](#).

4. Press the Power On/Standby button.
5. Decide how to manage the server:
 - Locally: Use a KVM switch or a connect a keyboard, monitor, and mouse.
 - Remotely: Connect to the iLO web interface and run a remote console:
 - a. Verify the following:
 - iLO is licensed to use the remote console feature.

If iLO is not licensed, visit the HPE website:

<https://www.hpe.com/info/ilo>
 - The iLO management port is connected to a secure network.
 - b. Using a browser, navigate to the iLO web interface, and then log in.
`https://<iLO hostname or IP address>`
 - c. Enter the iLO login name and password, and then click **Log In**.
 - d. In the navigation tree, click the **Remote Console & Media** link, and then launch a remote console.
6. Configure the initial server setup.
7. Set up the storage.
8. Deploy an OS or virtualization software.
9. After the OS is installed, update the drivers.

Operational requirements

When preparing and planning the installation, observe the following operational requirements:

- Space and airflow requirements

- [Temperature requirements](#)
- [Power requirements](#)
- [Electrical grounding requirements](#)

For environmental requirements, see [Environmental specifications](#).

Subtopics

[Space and airflow requirements](#)

[Temperature requirements](#)

[Power requirements](#)

[Electrical grounding requirements](#)

Space and airflow requirements

To allow for servicing and adequate airflow, observe the following space and airflow requirements when installing the server in an indoor commercial rack:

- 63.50 cm (25.00 in) in front of the rack
- 76.20 cm (30.00 in) behind the rack
- 121.90 cm (48.00 in) from the back of the rack to the back of another rack or row of racks

Observe the following:

- Servers draw in cool air through the front of the rack and expel warm air through the rear. The front and rear rack doors must be adequately ventilated to allow ambient air to enter the cabinet. The rear door must be adequately ventilated to allow the warm air to escape from the cabinet.



CAUTION

To prevent improper cooling and damage to the equipment, do not block the ventilation openings.



CAUTION

When the vertical space in the rack is not filled by a server or rack component, the gaps between the components can cause changes in airflow through the rack and around the servers. Cover all gaps with blanking panels to maintain proper airflow. Using a rack without blanking panels results in improper cooling which can lead to thermal damage.

- If a third-party rack is used, observe the following additional requirements to ensure adequate airflow and prevent damage to the equipment:
 - Front and rear doors—If the 42U rack includes closing front and rear doors, you must allow 5,350 sq cm (830 sq in) of holes evenly distributed from top to bottom to permit adequate airflow (equivalent to the required 64 percent open area for ventilation).
 - Side—The clearance between the installed rack component and the side panels of the rack must be a minimum of 7.00 cm (2.75 in).

Temperature requirements

To ensure continued safe and reliable equipment operation, install or position the system in a well-ventilated, climate-controlled environment.

The maximum recommended ambient operating temperature (TMRA) for most server products is 35°C (95°F). The temperature in the room where the rack is located must not exceed 35°C (95°F).



CAUTION

To reduce the risk of damage to the equipment when installing third-party options:

- Do not permit optional equipment to impede airflow around the server or to increase the internal rack temperature beyond the maximum allowable limits.
- Do not exceed the manufacturer's TMRA.

Power requirements

Installation of this equipment must comply with local and regional electrical regulations governing the installation of information technology equipment by licensed electricians. This equipment is designed to operate in installations covered by NFPA 70, 1999 Edition (National Electric Code) and NFPA-75, 1992

(code for Protection of Electronic Computer/Data Processing Equipment). For electrical power ratings on options, refer to the product rating label or the user documentation supplied with that option.



WARNING

To reduce the risk of personal injury, fire, or damage to the equipment, do not overload the AC supply branch circuit that provides power to the rack. Consult the electrical authority having jurisdiction over wiring and installation requirements of your facility.



CAUTION

Protect the server from power fluctuations and temporary interruptions with a regulating uninterruptible power supply. This device protects the hardware from damage caused by power surges and voltage spikes and keeps the system in operation during a power failure.

Electrical grounding requirements

The server must be grounded properly for proper operation and safety. In the United States, you must install the equipment in accordance with NFPA 70, National Electric Code Article 250, as well as any local and regional building codes. In Canada, you must install the equipment in accordance with Canadian Standards Association, CSA C22.1, Canadian Electrical Code. In all other countries, you must install the equipment in accordance with any regional or national electrical wiring codes, such as the International Electrotechnical Commission (IEC) Code 364, parts 1 through 7. Furthermore, you must be sure that all power distribution devices used in the installation, such as branch wiring and receptacles, are listed or certified grounding-type devices.

Because of the high ground-leakage currents associated with multiple servers connected to the same power source, Hewlett Packard Enterprise recommends the use of a PDU that is either permanently wired to the building's branch circuit or includes a nondetachable cord that is wired to an industrial-style plug. NEMA locking-style plugs or those complying with IEC 60309 are considered suitable for this purpose. Using common power outlet strips for the server is not recommended.

Rack warnings and cautions



WARNING

When all components are removed, the server weighs 12.00 kg (26.45 lb). When all components are installed, the server can weigh up to 29.60 kg (65.23 lb).

Before configuring your rack solution, be sure to check the rack manufacturer weight limits and specifications. Failure to do so can result in physical injury or damage to the equipment and the facility.



WARNING

The server is heavy. To reduce the risk of personal injury or damage to the equipment, do the following:

- Observe local occupational health and safety requirements and guidelines for manual material handling.
- Get help to lift and stabilize the product during installation or removal, especially when the product is not fastened to the rails. The server weighs more than 12.00 kg (26.45 lb), so at least two people must lift the server into the rack together. An additional person may be required to help align the server if the server is installed higher than chest level.
- Use caution when installing the server in or removing the server from the rack.
- Adequately stabilize the rack before extending a component outside the rack. Extend only one component at a time. A rack may become unstable if more than one component is extended.
- Do not stack anything on top of rail-mounted component or use it as a work surface when extended from the rack.



WARNING

To reduce the risk of personal injury or damage to the equipment, be sure that:

- The rack has anti-tip measures in place. Such measures include floor-bolting, anti-tip feet, ballast, or a combination as specified by the rack manufacturer and applicable codes.
- The leveling jacks (feet) are extended to the floor.
- The full weight of the rack rests on the leveling jacks (feet).

Server warnings and cautions



WARNING

To reduce the risk of personal injury, electric shock, or damage to the equipment, disconnect the power cord to remove power from the server. Pressing the Power On/Standby button does not shut off system power completely. Portions of the power supply and some internal circuitry remain active until AC power is removed.



WARNING

To reduce the risk of personal injury from hot surfaces, allow the drives and the internal system components to cool before touching them.



WARNING

To reduce the risk of fire or burns after removing the energy pack:

- Do not disassemble, crush, or puncture the energy pack.
- Do not short external contacts.
- Do not dispose of the energy pack in fire or water.
- Do not expose the energy pack to low air pressure as it might lead to explosion or leakage of flammable liquid or gas.
- Do not expose the energy pack to temperatures higher than 60°C (140°F).

After power is disconnected, battery voltage might still be present for 1s to 160s.



CAUTION

Protect the server from power fluctuations and temporary interruptions with a regulating UPS. This device protects the hardware from damage caused by power surges and voltage spikes and keeps the server in operation during a power failure.



CAUTION

To prevent damage to electrical components, properly ground the server before beginning any installation, removal, or replacement procedure. Improper grounding can cause electrostatic discharge.



CAUTION

To avoid data loss, Hewlett Packard Enterprise recommends that you back up

Electrostatic discharge

Be aware of the precautions you must follow when setting up the system or handling components. A discharge of static electricity from a finger or other conductor may damage system boards or other static-sensitive devices. This type of damage may reduce the life expectancy of the system or component.

To prevent electrostatic damage:

- Avoid hand contact by transporting and storing products in static-safe containers.
- Keep electrostatic-sensitive parts in their containers until they arrive at static-free workstations.
- Place parts on a grounded surface before removing them from their containers.
- Avoid touching pins, leads, or circuitry.
- Always be properly grounded when touching a static-sensitive component or assembly. Use one or more of the following methods when handling or installing electrostatic-sensitive parts:
 - Use a wrist strap connected by a ground cord to a grounded workstation or computer chassis. Wrist straps are flexible straps with a minimum of 1 megohm \pm 10 percent resistance in the ground cords. To provide proper ground, wear the strap snug against the skin.
 - Use heel straps, toe straps, or boot straps at standing workstations. Wear the straps on both feet when standing on conductive floors or dissipating floor mats.
 - Use conductive field service tools.
 - Use a portable field service kit with a folding static-dissipating work mat.

If you do not have any of the suggested equipment for proper grounding, have an authorized reseller install the part.

For more information on static electricity or assistance with product installation, contact an authorized reseller.

Operations

This chapter describes the hardware operations carried out prior to and after installing or removing a hardware component, or performing a server maintenance or troubleshooting procedure. Before performing these hardware operations, review the:

- [Rack warnings and cautions](#)

- [Server warnings and cautions](#)

Subtopics

[Power up the server](#)

[Power down the server](#)

[Open the cable management arm](#)

[Extend the server out of the rack](#)

[Remove the server from the rack](#)

[Remove the front bezel](#)

[Remove the access panel](#)

[Remove the M.2 air baffle](#)

[Remove the middle cover](#)

[Remove the fan](#)

[Remove the fan wall](#)

[Remove the riser cage](#)

[Install the access panel](#)

[Install the M.2 air baffle](#)

[Install the middle cover](#)

[Install the fan wall](#)

[Install the riser cage](#)

[Install the server into the rack](#)

Power up the server

Procedure

- Press the Power On/Standby button.
- Use the virtual power button through iLO 6.

Power down the server

Before powering down the server for any upgrade or maintenance procedures, perform a backup of critical server data and programs.



IMPORTANT

When the server is in standby mode, auxiliary power is still being provided to the system.

To power down the server, use one of the following methods:

- Press and release the Power On/Standby button.
This method activates a controlled shutdown of applications and the OS before the server enters standby mode. It can also activate a shutdown behavior governed by an OS configuration or policy.
- Press and hold the Power On/Standby button for more than 4 seconds to force the server to enter standby mode.
This method forces the server to enter standby mode without properly exiting applications and the OS. If an application stops responding, you can use this method to force a shutdown.
- Use a virtual power button selection through iLO 6.
This method initiates a controlled remote shutdown of applications and the OS before the server enters standby mode.

Before proceeding, verify that the server is in standby mode by observing that the system power LED is amber.

Open the cable management arm

Procedure

1. Press and hold the blue **PUSH** button on the retention bracket.
2. Swing the arm away from the rear panel.

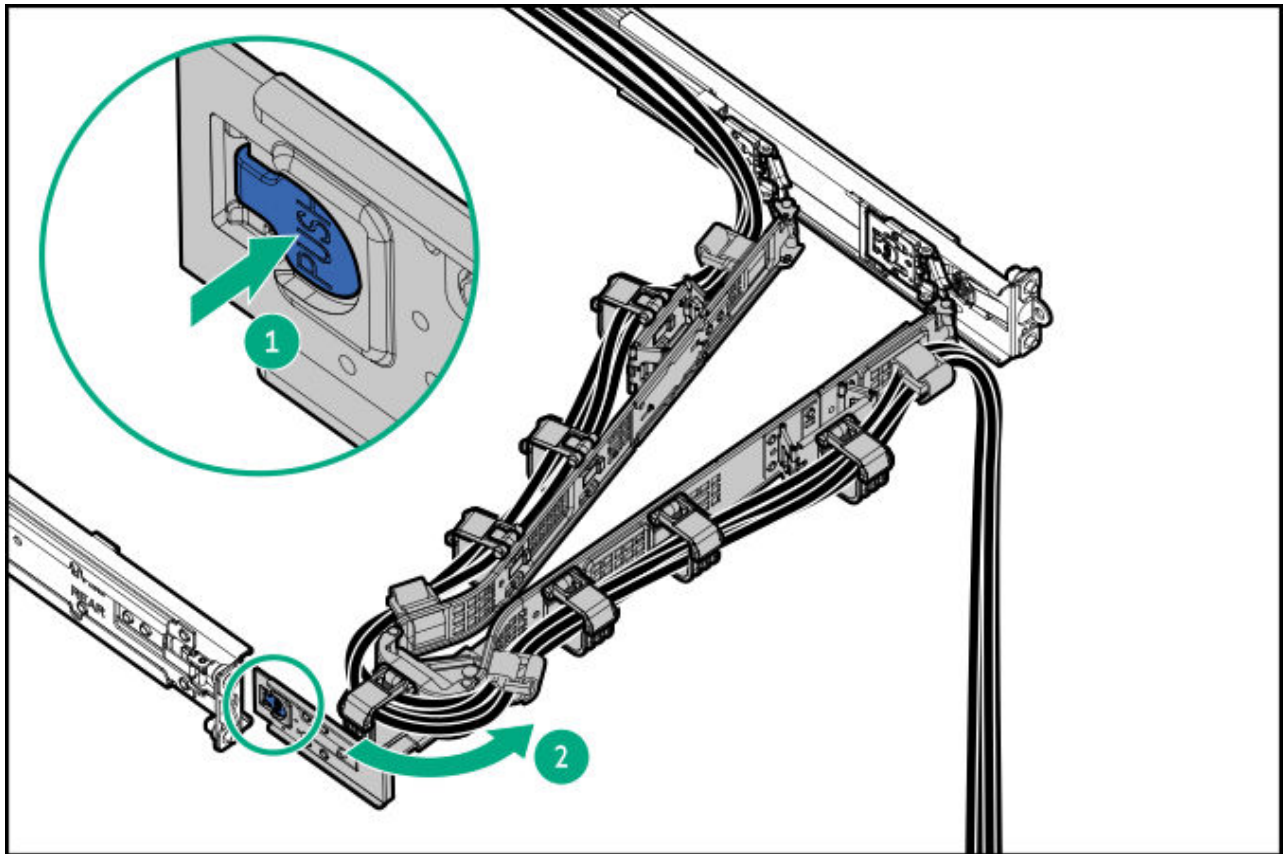

Extend the server out of the rack

Prerequisites

- Before you perform this procedure, review the [Rack warnings and cautions](#).
- T-25 Torx screwdriver—This tool is required if the shipping screws located inside the chassis ears are secured.

About this task



WARNING

To reduce the risk of personal injury, be careful when pressing the server rail-release latches. The inner rails could pinch your fingers.

Procedure

1. If needed, loosen the shipping screws, and then use the chassis ear latches to slide the server out of the rack until the rail-release latches are engaged.

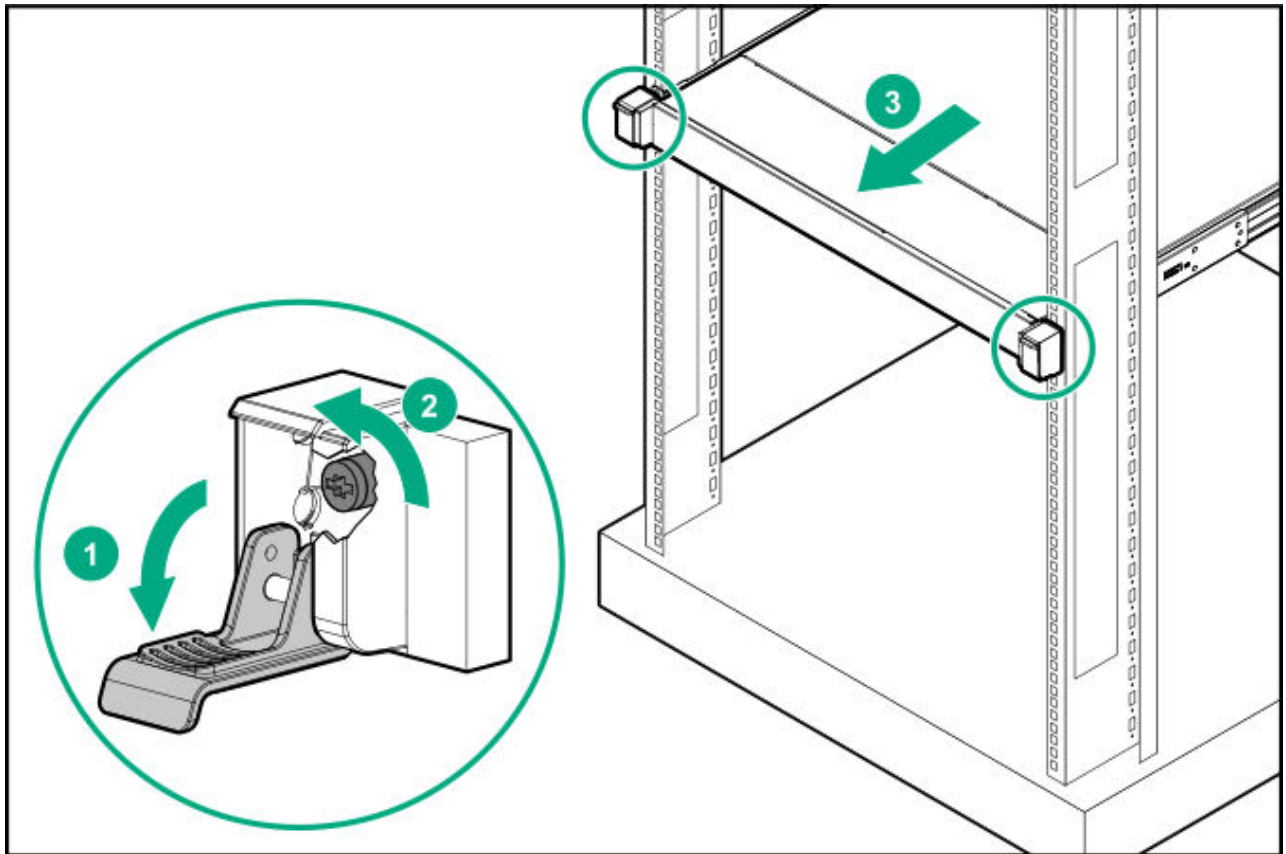

2. Press and hold the rear-end rail-release latches, and then slide the server out of the rack until it is fully extended.



WARNING

To reduce the risk of personal injury, be careful when pressing the server rail-release latches. The inner rails could pinch your fingers.

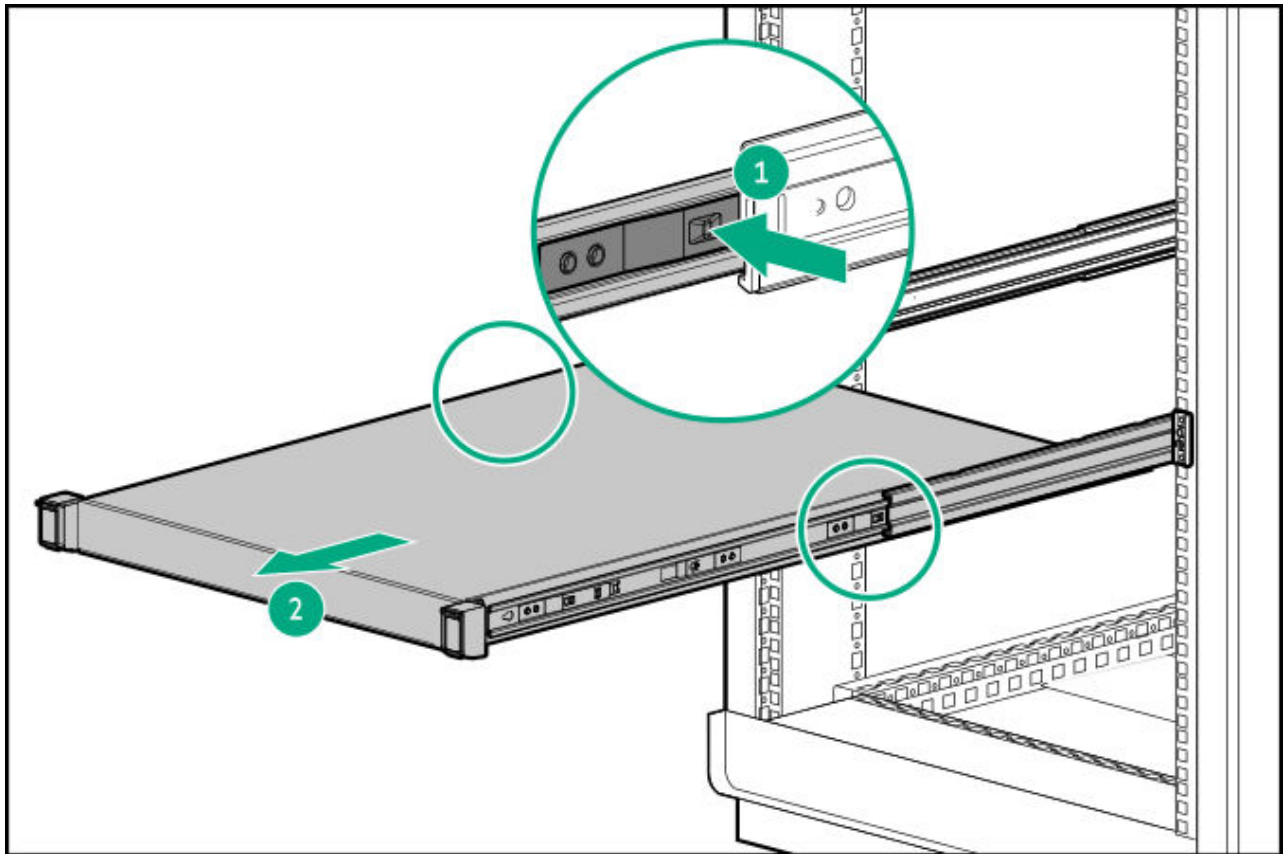

Remove the server from the rack

Prerequisites

- Get help to lift and stabilize the server during removal from the rack. **If the server is installed higher than chest level, additional two people might be required to help remove the server:** One person to support the server weight, and the other two to slide the server out of the rack.
- Before you perform this procedure, review the:
 - [Rack warnings and cautions](#)
 - [Server warnings and cautions](#)
- A fully populated server is heavy. Hewlett Packard Enterprise recommends removing the external chassis components before removing the server from the rack.

Procedure

1. [Power down the server.](#)

2. If installed, open the cable management arm.
3. Remove all power:
 - a. Disconnect each power cord from the power source.
 - b. Disconnect each power cord from the server.
4. Disconnect all peripheral cables from the server.
5. Fully extend the server out of the rack.
6. Slide the server completely out of the rack.

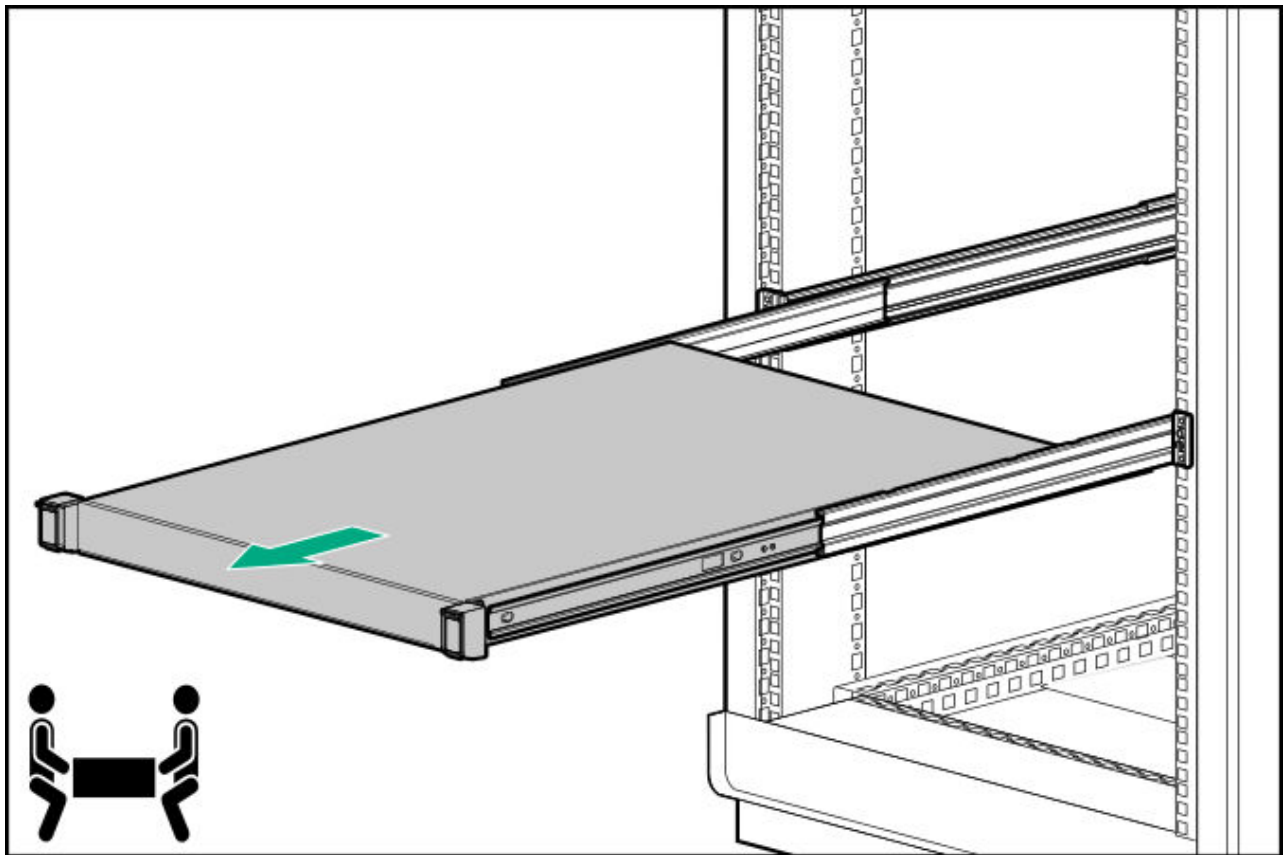

7. Place the server on a flat, level work surface.

Remove the front bezel

About this task

If you are using the virtual power button in iLO to power the server on/off, you do not need to remove the front bezel. Remove the front bezel only if you need to access the front panel components.

Procedure

1. If installed, remove the Kensington security lock.

For more information, see the lock documentation.

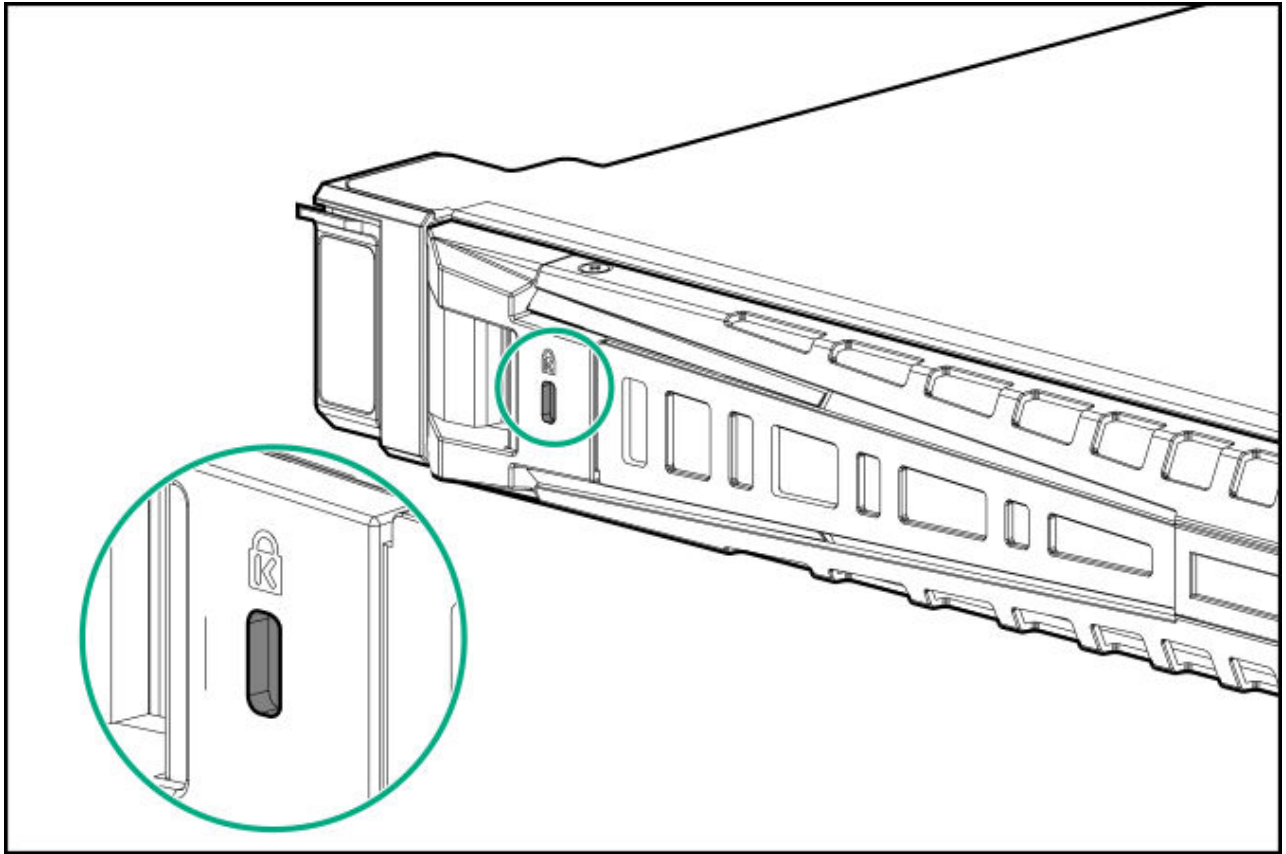

2. Press the bezel release latch, and then pivot the bezel open.
3. Release the right side of the bezel from the front panel.

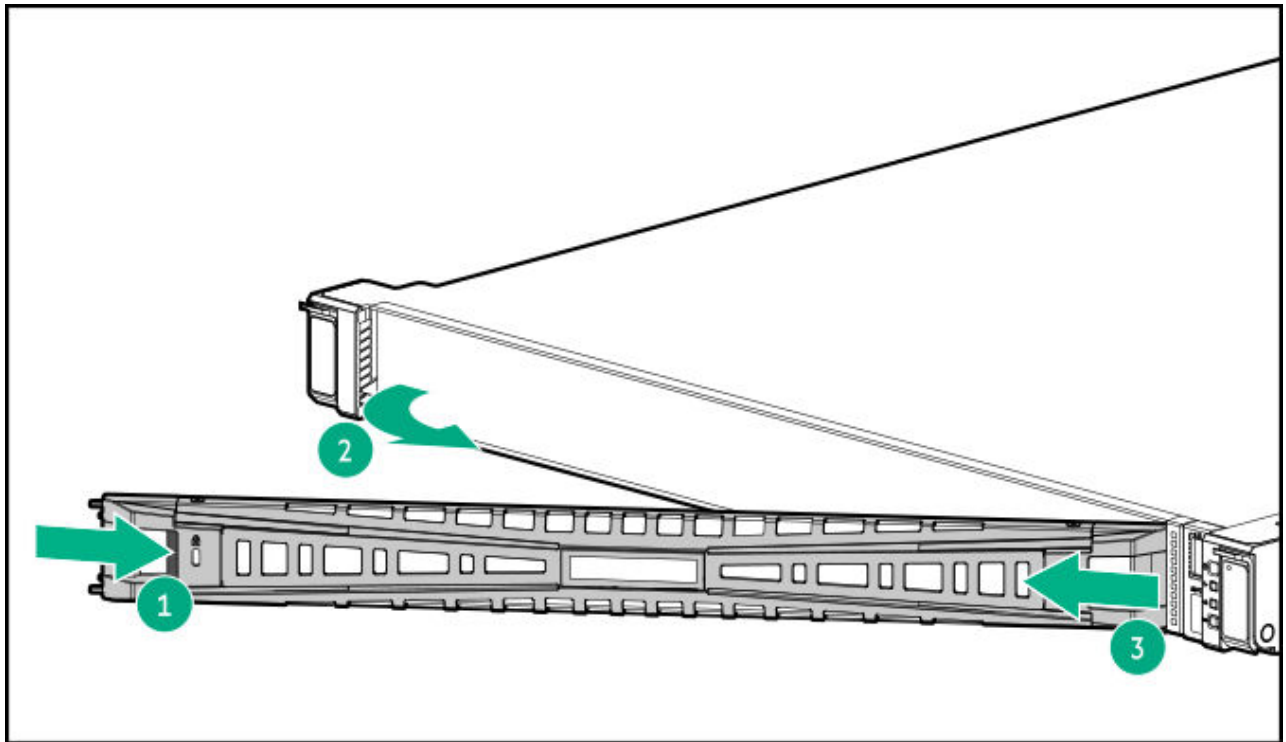

Remove the access panel

Prerequisites

Before you perform this procedure, make sure that you have a T-15 Torx screwdriver available.

About this task



WARNING

To reduce the risk of personal injury from hot surfaces, allow the drives and the internal system components to cool before touching them.



CAUTION

To prevent damage to electrical components, properly ground the server before beginning any installation, removal, or replacement procedure. Improper grounding can cause electrostatic discharge.



CAUTION

Do not operate the server for long periods with the access panel open or removed. Operating the server in this manner results in improper airflow and improper cooling that can lead to thermal damage.

Procedure

1. Power down the server.
2. Remove all power:
 - a. Disconnect each power cord from the power source.
 - b. Disconnect each power cord from the server.
3. Disconnect all peripheral cables from the server.
4. Do one of the following:
 - a. Extend the server from the rack.
 - b. Remove the server from the rack.
5. Remove the access panel:
 - a. If necessary, unlock the access panel latch.
 - b. To disengage the access panel from the chassis, press the release button and pull up the latch.
 - c. Lift the access panel.

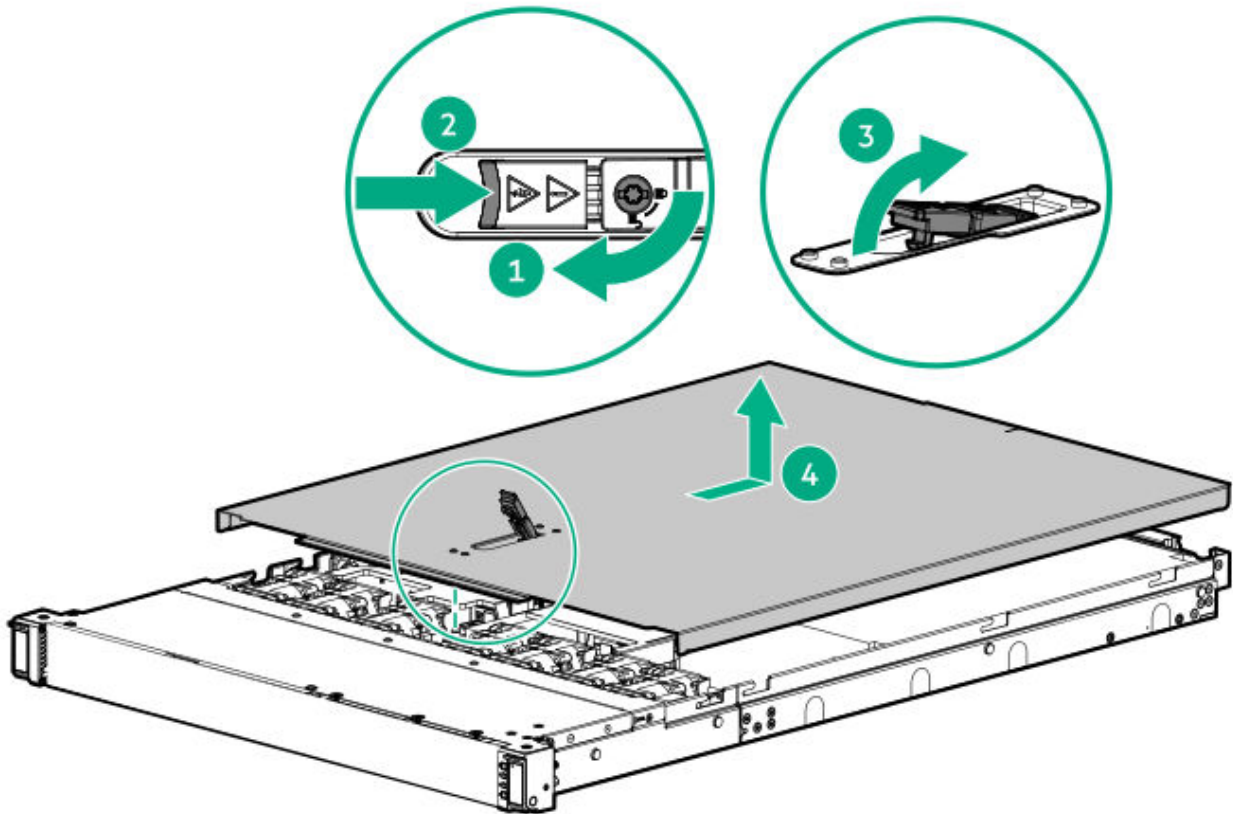

Remove the M.2 air baffle

Procedure

1. Power down the server.
2. If installed, open the cable management arm.
3. Remove all power:
 - a. Disconnect each power cord from the power source.
 - b. Disconnect each power cord from the server.
4. Disconnect all peripheral cables from the server.
5. Do one of the following:
 - a. Extend the server from the rack.
 - b. Remove the server from the rack.

6. Remove the access panel.
7. Remove the M.2 air baffle.

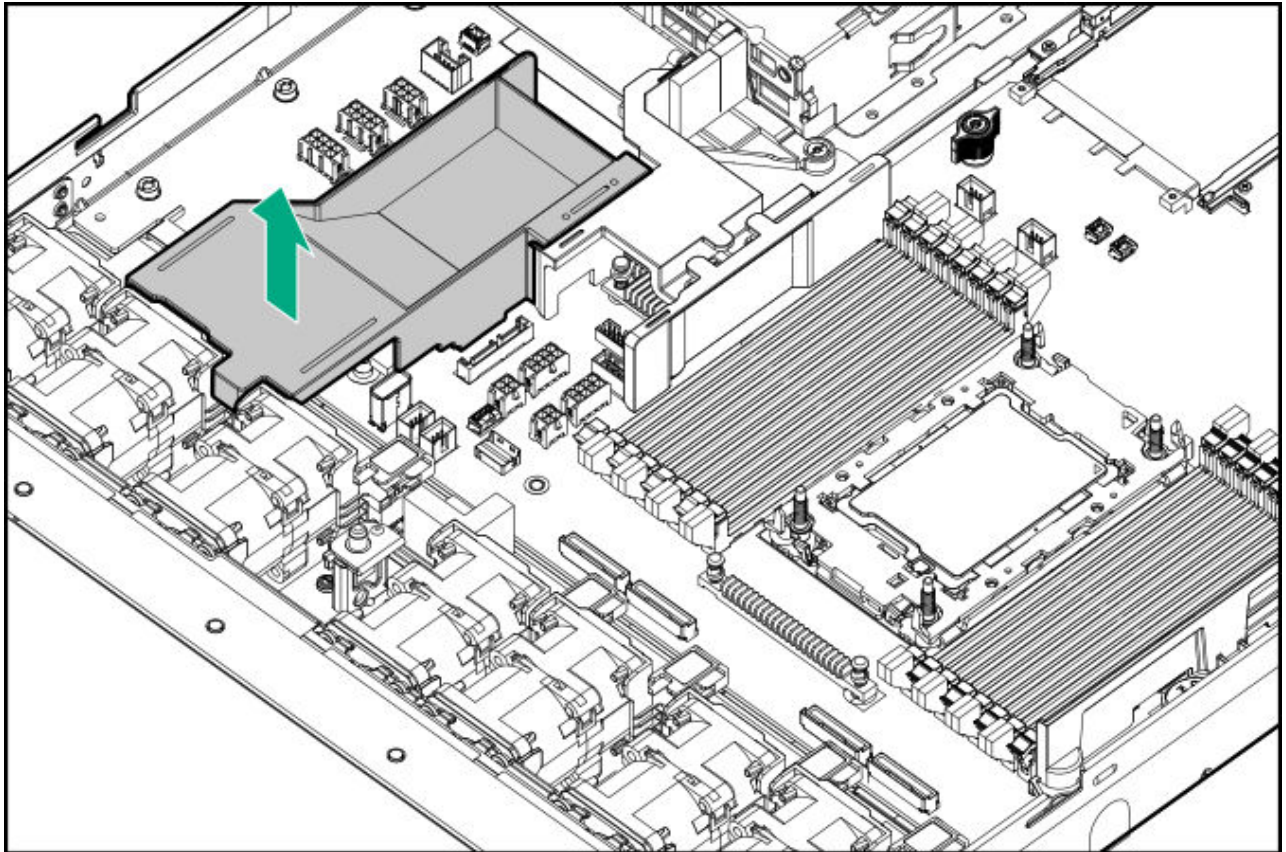

Remove the middle cover

Prerequisites

Before you perform this procedure, make sure that you have a T-10 Torx screwdriver available.

This tool is required to remove the middle cover from servers with a GPU riser cage.

About this task



CAUTION

For proper cooling, do not operate the server without the access panel, baffles, expansion slot covers, or blanks installed.



CAUTION

To prevent damage to electrical components, properly ground the server before beginning any installation, removal, or replacement procedure. Improper grounding can cause electrostatic discharge.

Procedure

1. Power down the server.
2. If installed, open the cable management arm.
3. Remove all power:
 - a. Disconnect each power cord from the power source.
 - b. Disconnect each power cord from the server.
4. Disconnect all peripheral cables from the server.
5. Do one of the following:
 - a. Extend the server from the rack.
 - b. Remove the server from the rack.
6. Remove the access panel.
7. To remove the middle cover from the LFF and the SFF drive configuration, take both sides of the middle cover and detach from the server.
 - LFF drive configuration

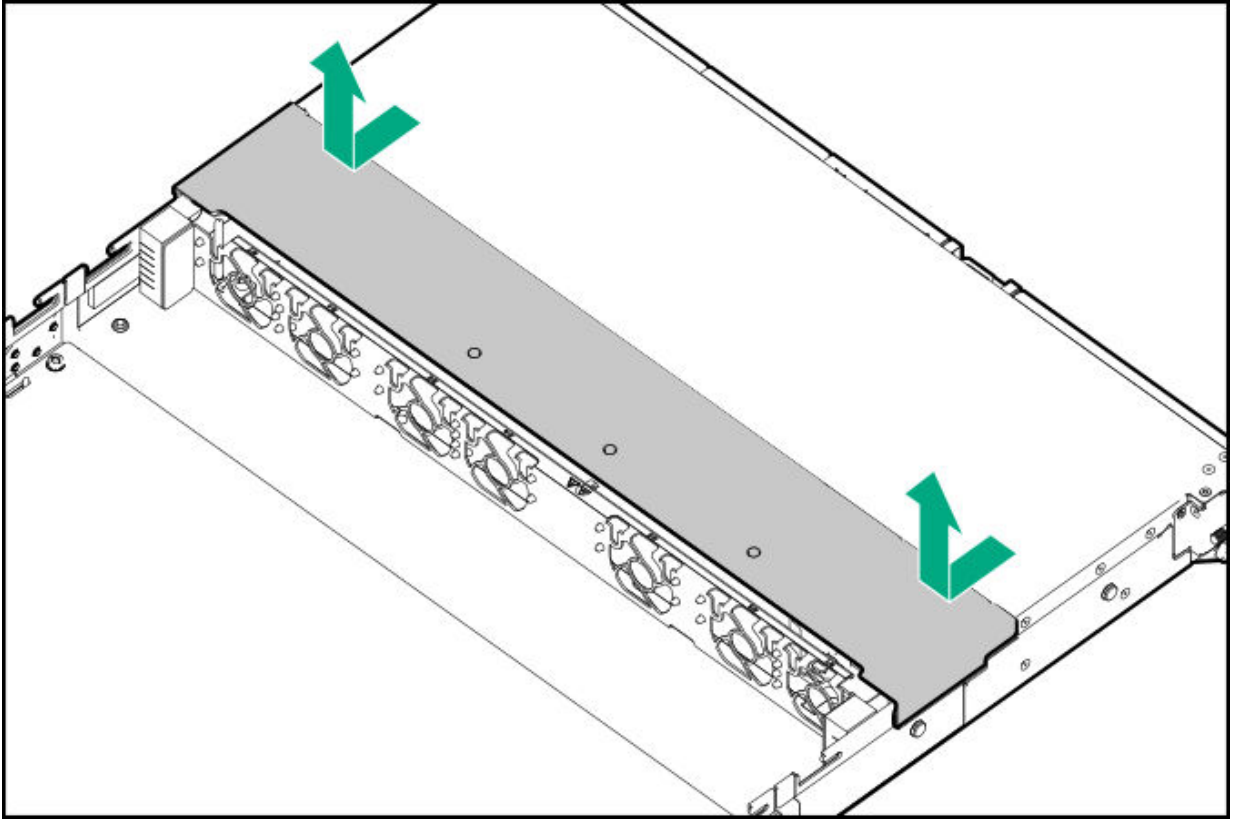

- SFF drive configuration

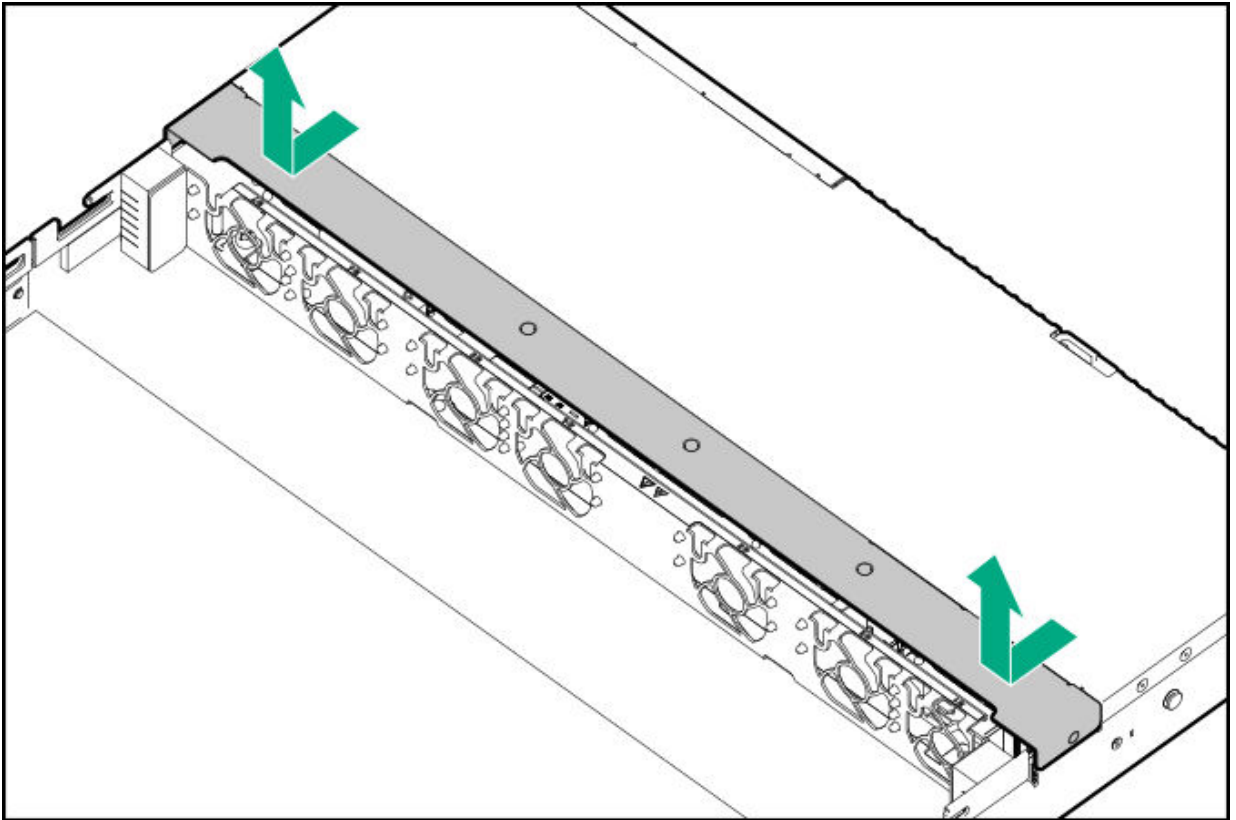

8. To remove the middle cover from a server with a GPU riser cage:
 - a. Remove the screws.
 - b. Take both sides of the middle cover and detach from the server.

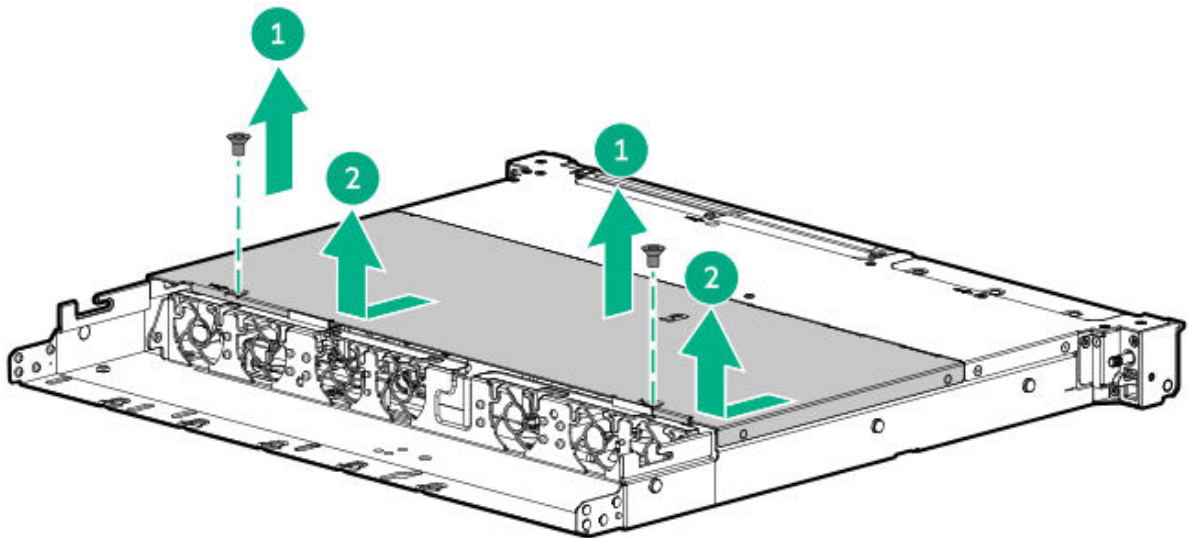

Remove the fan

About this task



CAUTION

To prevent improper cooling and thermal damage, do not operate the server unless all bays are populated with either a component or a blank.



IMPORTANT

The fan setup can either be standard, single-rotor fans or high performance, dual-rotor fans. Do not mix fan types in the same server.

Procedure

1. Power down the server.
2. If installed, open the cable management arm.
3. Remove all power:

- a. Disconnect each power cord from the power source.
- b. Disconnect each power cord from the server.
4. Disconnect all peripheral cables from the server.
5. Do one of the following:
 - a. Extend the server from the rack.
 - b. Remove the server from the rack.
6. Remove the access panel.
7. Remove the fan.

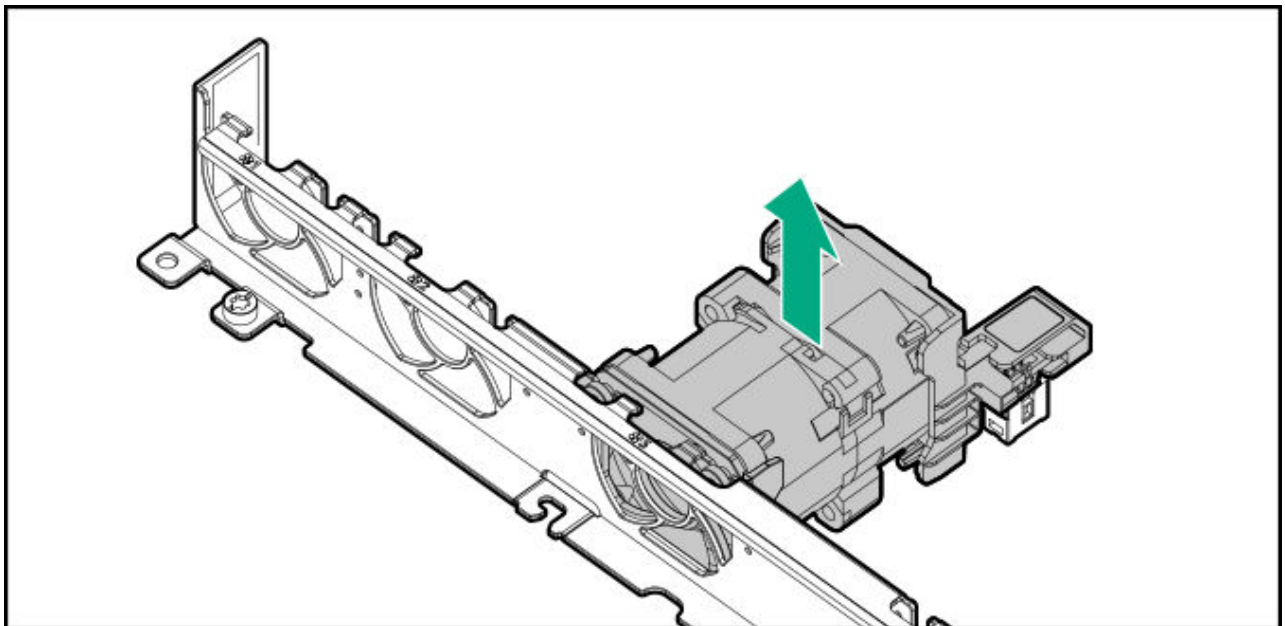

Remove the fan wall

Prerequisites

Before you perform this procedure, make sure that you have the following items available:

- T-15 Torx screwdriver
- T-10 Torx screwdriver—This tool is required to remove the fan wall from the 12 LFF or the 4 SFF or 8 E3.S drive configuration.

Procedure

1. Power down the server.
2. If installed, open the cable management arm.
3. Remove all power:
 - a. Disconnect each power cord from the power source.
 - b. Disconnect each power cord from the server.
4. Disconnect all peripheral cables from the server.
5. Remove the server from the rack.
6. Remove the access panel.
7. Remove the middle cover.
8. Remove the fans.
9. Remove the fan wall.

Retain the screws and fan wall. These screws will be used to secure the fan wall after replacing or installing the internal component.

- SFF or 4 LFF drive configuration:

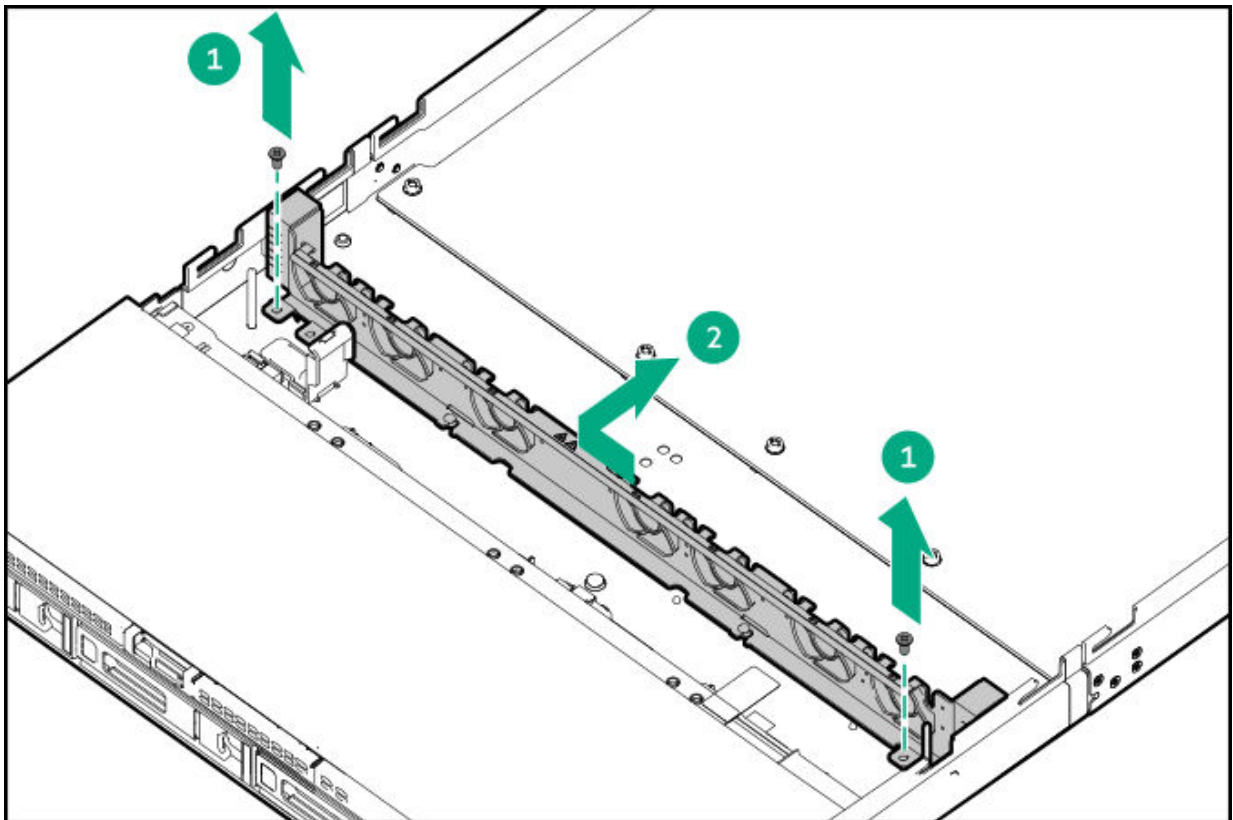

- 12 LFF drive configuration:

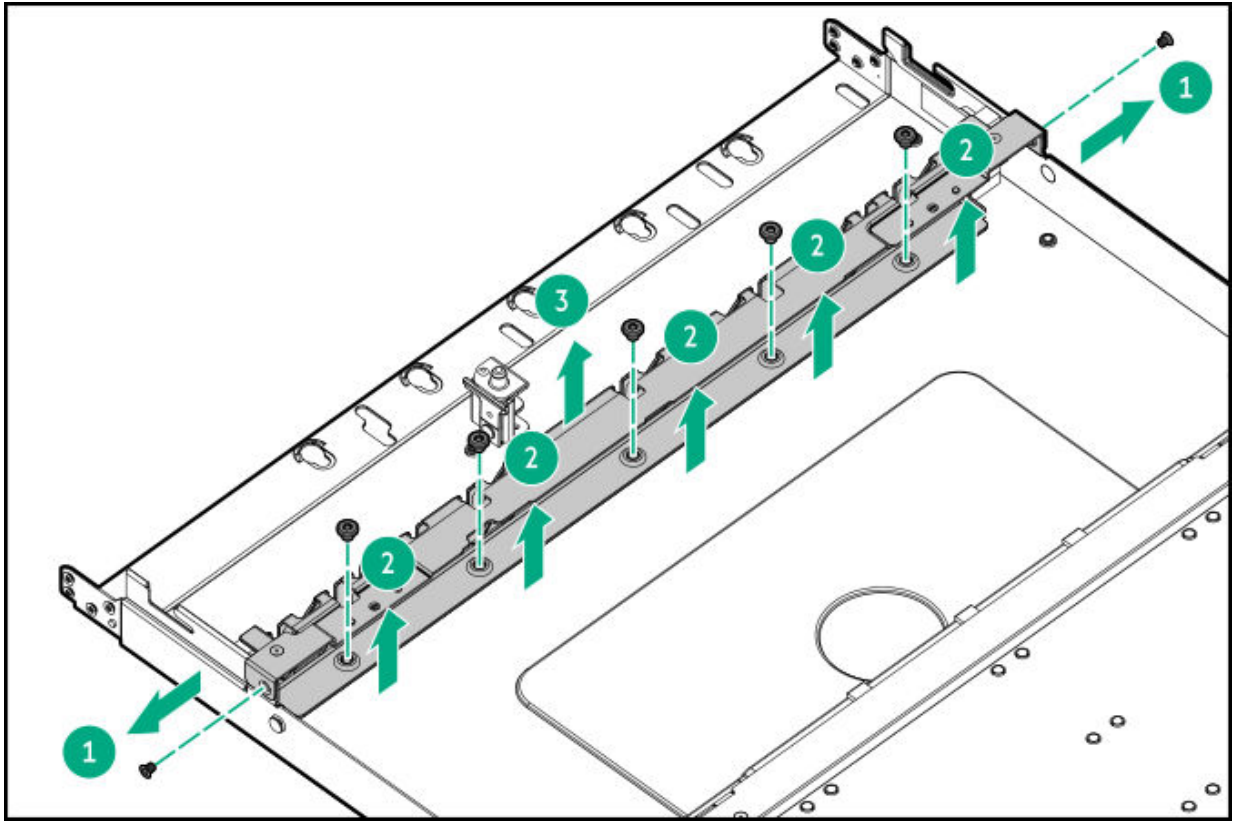

- 4 SFF or 8 E3.S drive configuration:

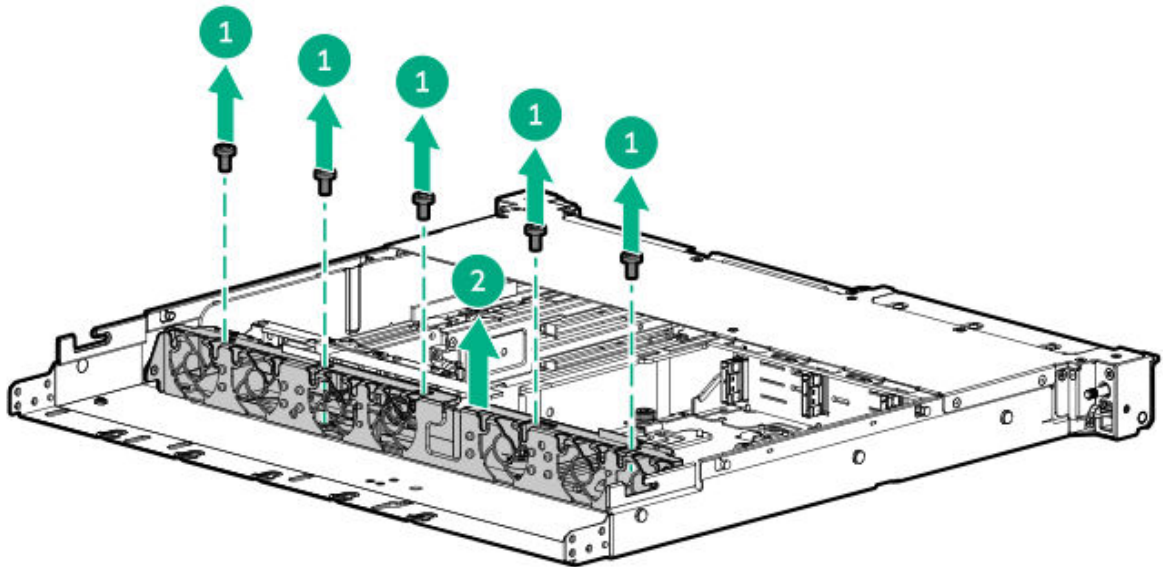

Remove the riser cage

Prerequisites

A T-10 Torx screwdriver is required to remove a GPU riser cage.

About this task



WARNING

To reduce the risk of personal injury from hot surfaces, allow the drives and the internal system components to cool before touching them.

Procedure

1. Power down the server.
2. If installed, open the cable management arm.
3. Remove all power:
 - a. Disconnect each power cord from the power source.
 - b. Disconnect each power cord from the server.
4. Disconnect all peripheral cables from the server.
5. Remove the server from the rack.
6. Place the server on a flat, level work surface.
7. Remove the access panel.
8. If an expansion card with internal cables is installed on the riser, disconnect the cables from the card.
9. If the storage controller backup cable is connected, disconnect the cable.
10. To remove the rear riser cage:
 - a. Release the half-turn spring latch.
 - b. Lift the riser cage off the system board.

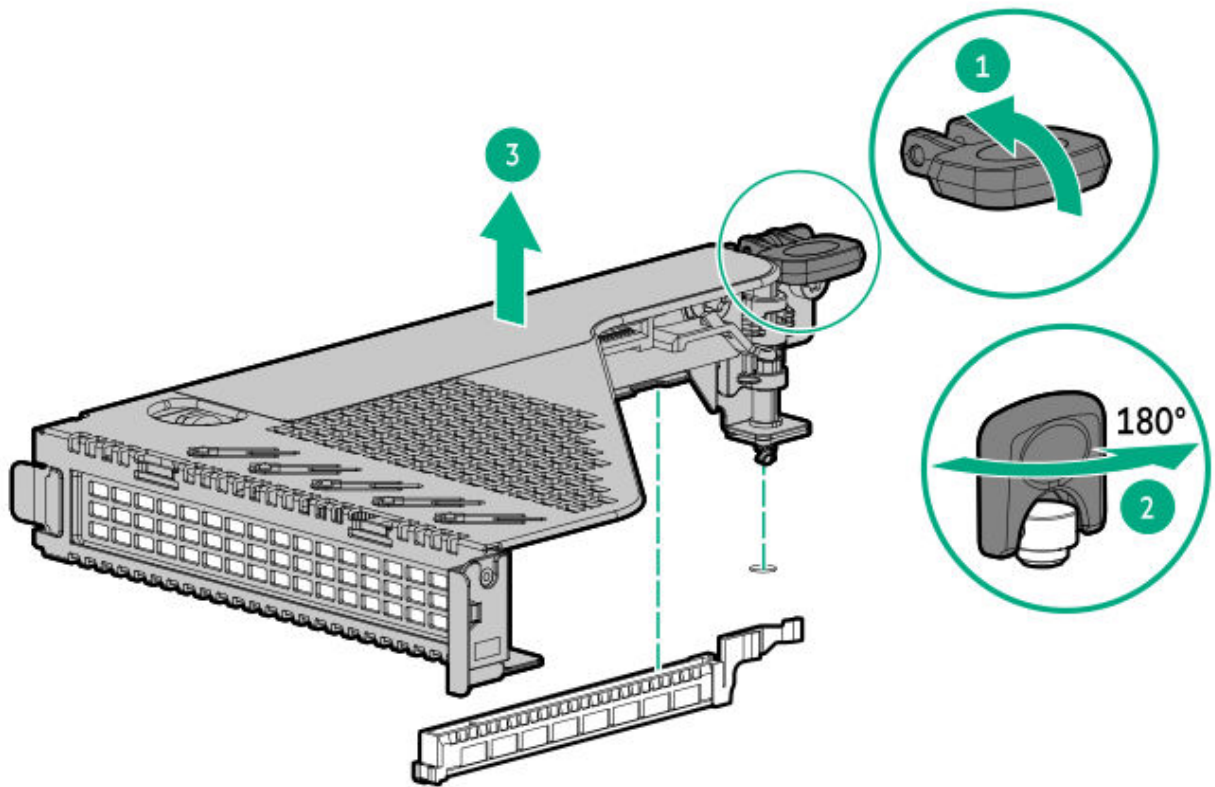

- .1. To remove the GPU riser cage, do the following:
 - a. Remove the two screws.
 - b. Push the cage forward and slide it out.

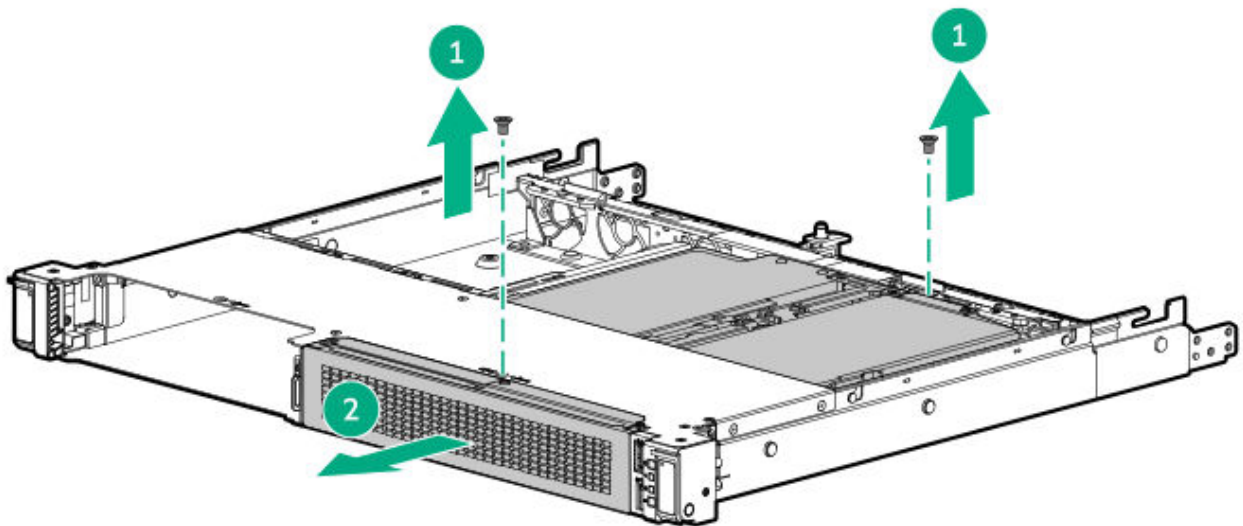

Install the access panel

Prerequisites

Before you perform this procedure, make sure that you have a T-15 Torx screwdriver available.

Procedure

1. With the access panel latch open, insert the guide pin on the chassis through the hole on the bottom side of the latch.

2. Close the access panel latch.

The access panel slides to the closed position.

3. Lock the access panel latch.

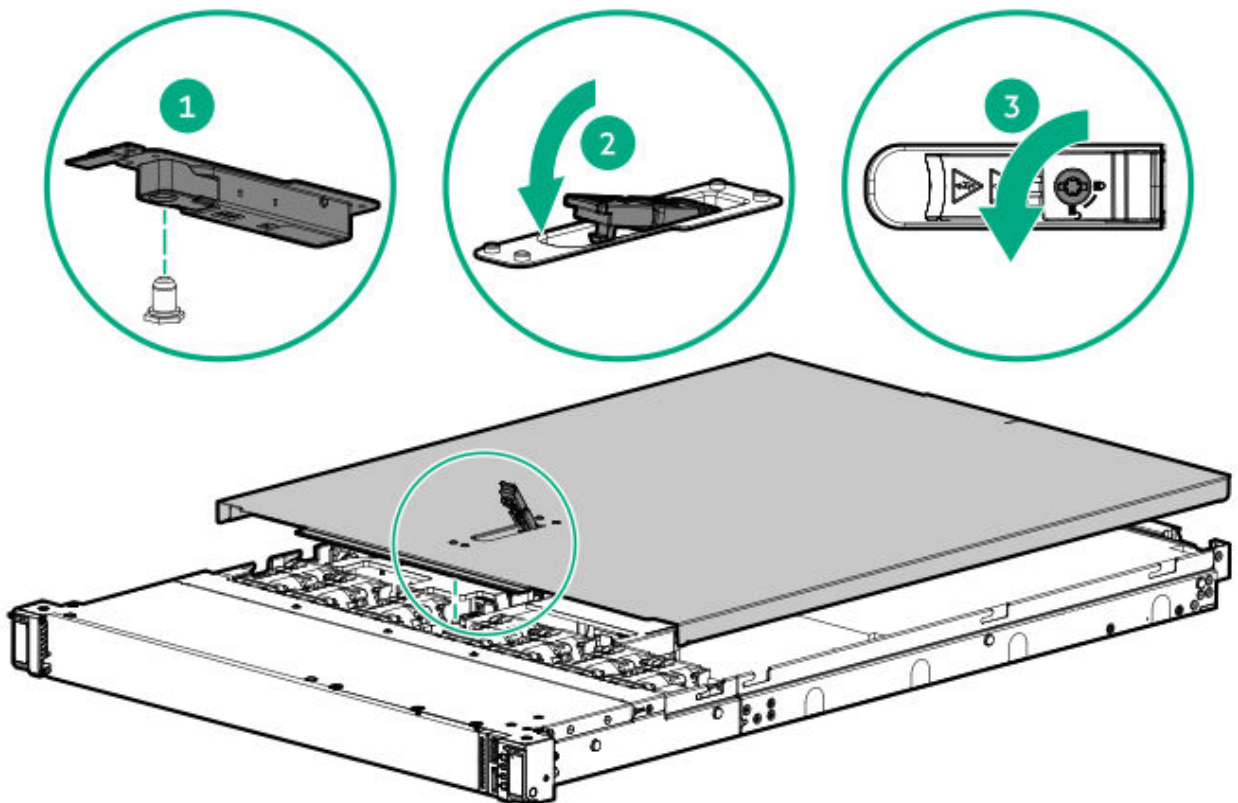

4. Perform the post-installation or maintenance steps required by the procedure that necessitates the removal of the access panel.

Install the M.2 air baffle

Procedure

Install the M.2 air baffle.

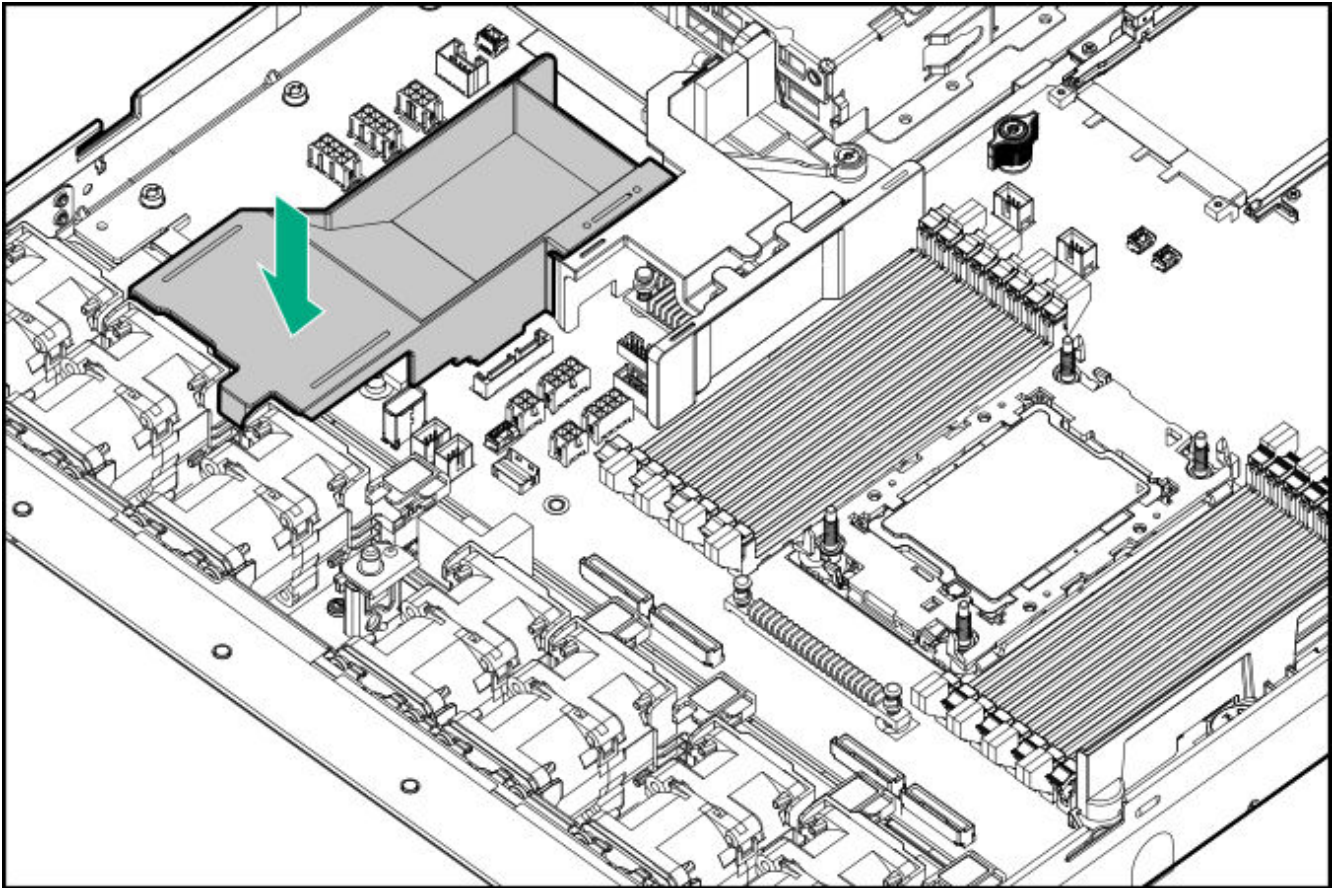

Install the middle cover

Prerequisites

A T-10 Torx screwdriver is required to install the middle cover on a server with a GPU riser cage.

Procedure

1. To install the middle cover on the LFF and SFF drive configuration, take both sides of the middle cover and install on the server.
 - LFF drive configuration

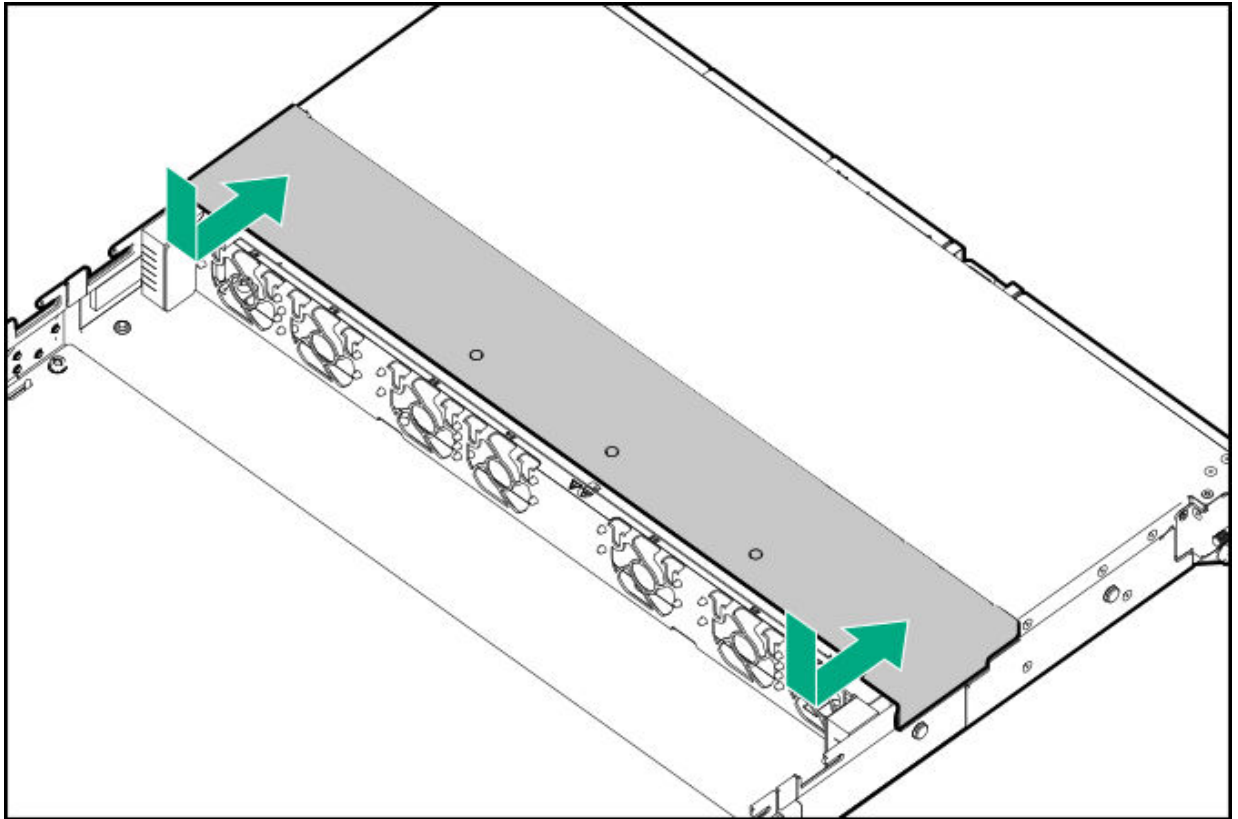

- SFF drive configuration

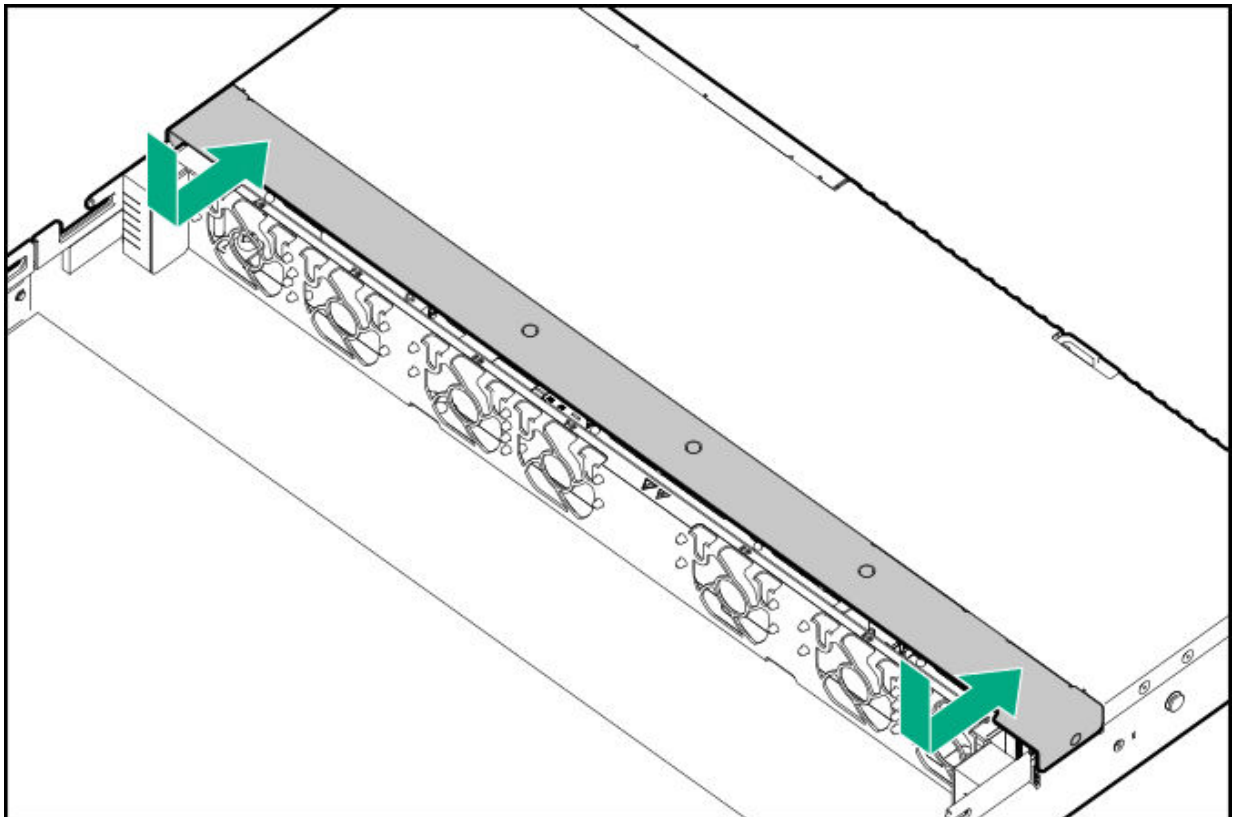

2. To install the middle cover on a server with a GPU riser cage:
 - a. Take both sides of the middle cover and attach on the server.
 - b. Install the screws.

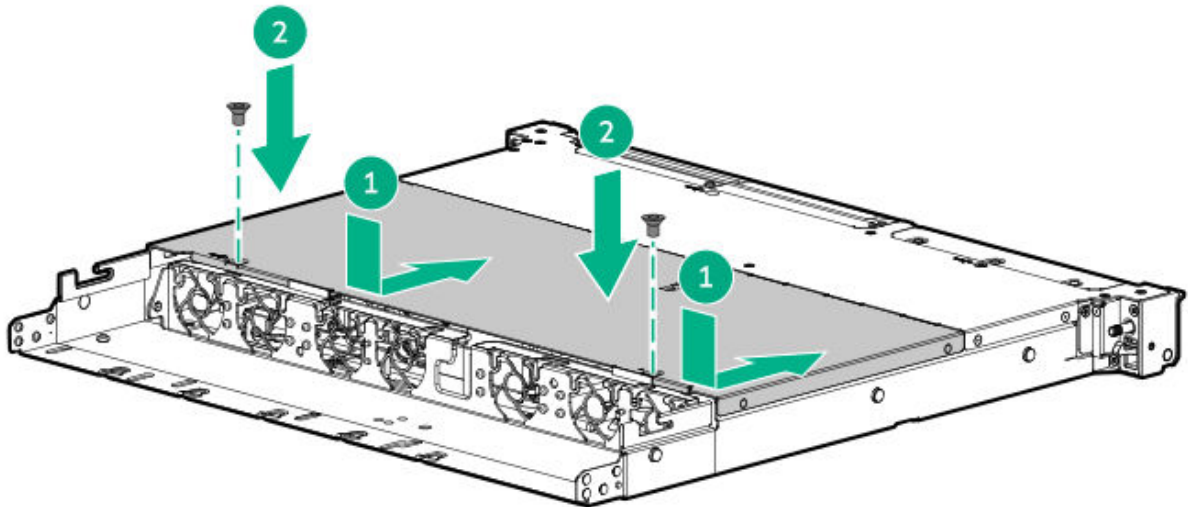

Install the fan wall

Prerequisites

Before you perform this procedure, make sure that you have the following items available:

- T-15 Torx screwdriver
- T-10 Torx screwdriver—This tool is required if you plan to install the fan wall in the 10 or 12 LFF drive configuration or the 4 SFF or 8 E3.S drive configuration.

Procedure

Install the fan wall.

Retain the screws and fan wall. These screws will be used to secure the fan wall after replacing or installing the internal component.

- SFF or 4 LFF drive configuration:

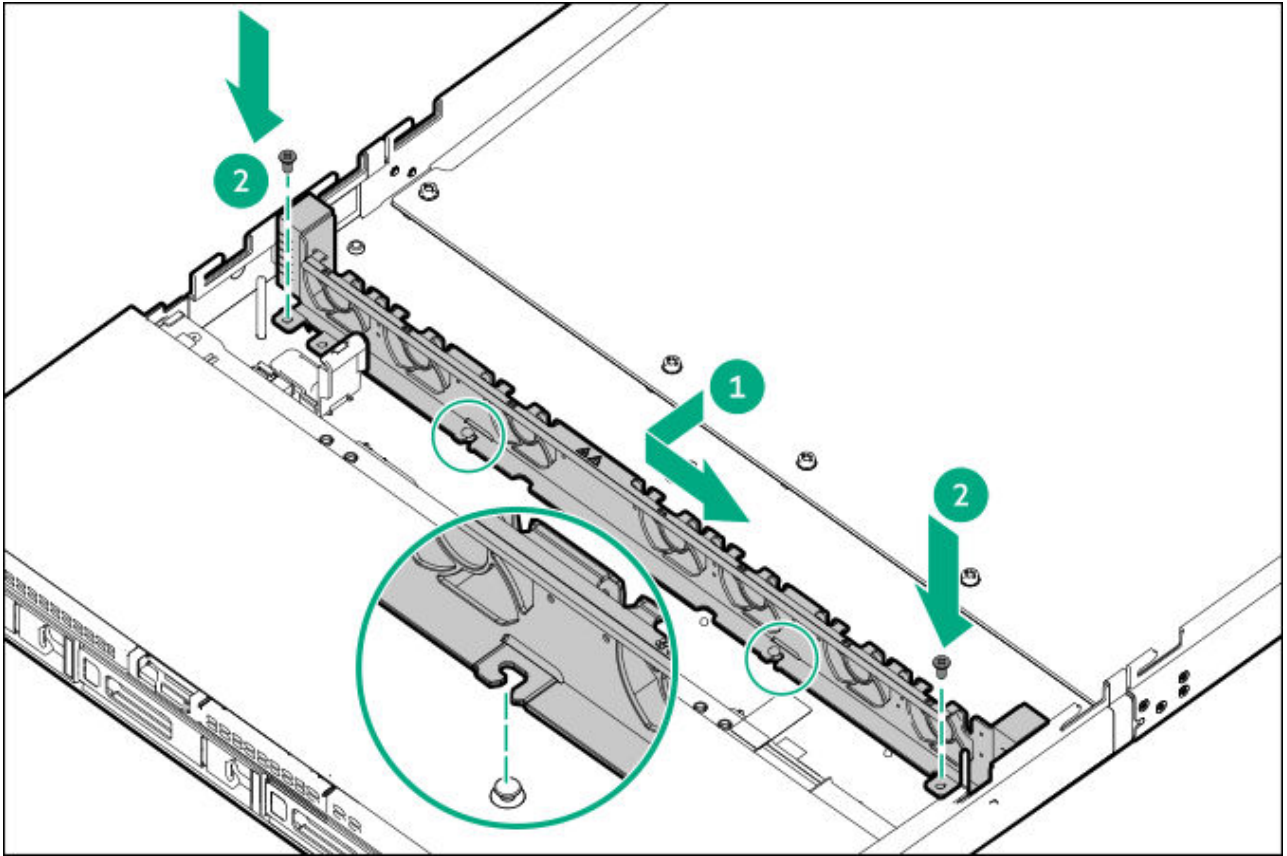

- 12 LFF drive configuration:

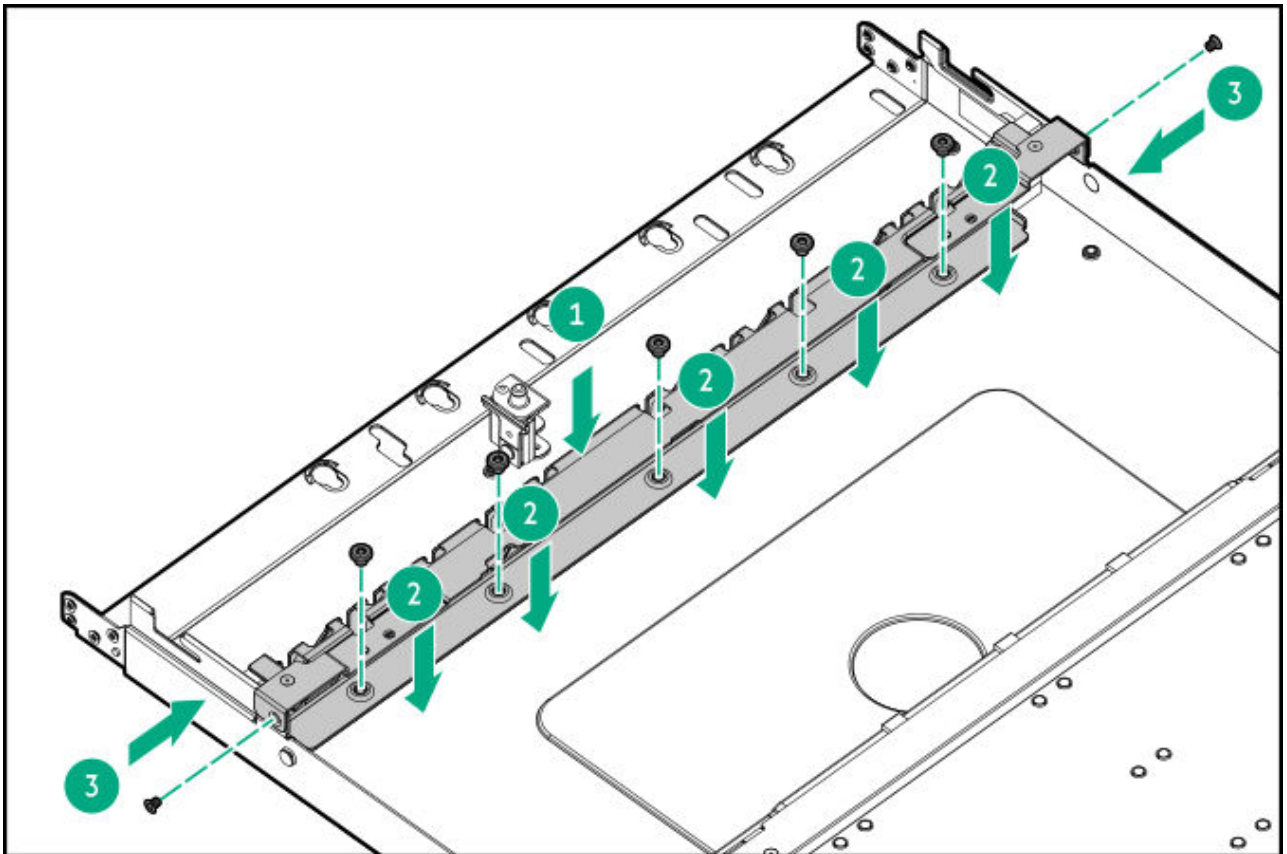

- 4 SFF or 8 E3.S drive configuration:

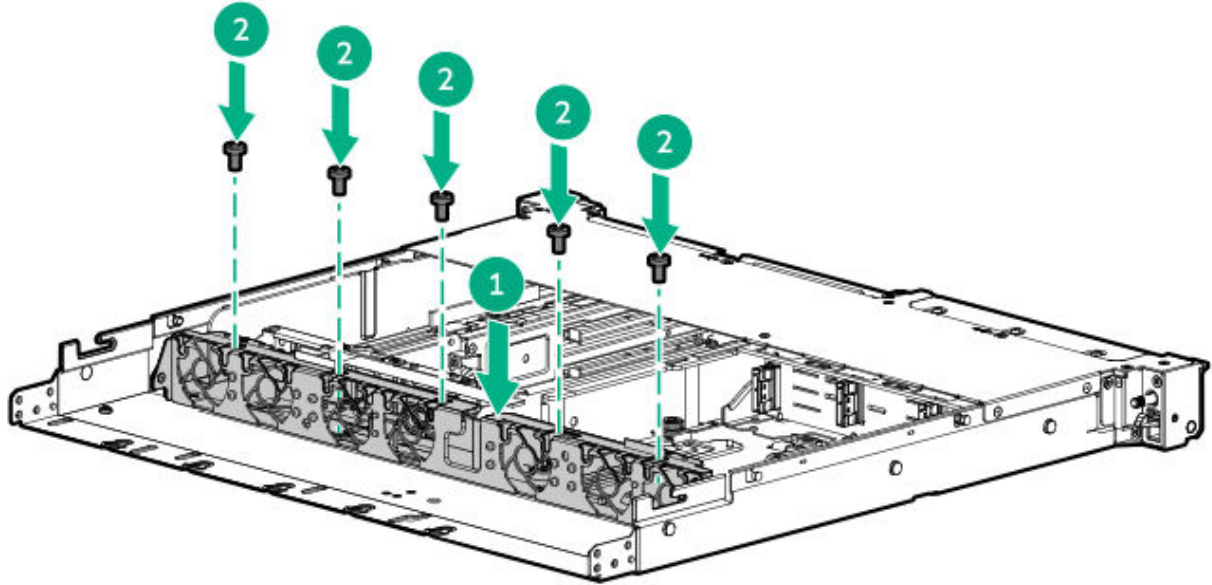

Install the riser cage

Prerequisites

A T-10 Torx screwdriver is required to install the GPU riser cage.

Procedure

1. If an expansion card or its internal cabling was removed, reinstall these components.
2. If a storage controller is installed, connect the storage controller backup cable.
3. To install the rear riser cage, do the following:
 - a. Carefully press the riser down on its system board connector.

Make sure that:

- The riser cage is aligned with the rear chassis.
 - The riser board is firmly seated on the system board.
- b. Simultaneously push and rotate the half-turn spring latch to 180°.
 - c. Close the spring latch.

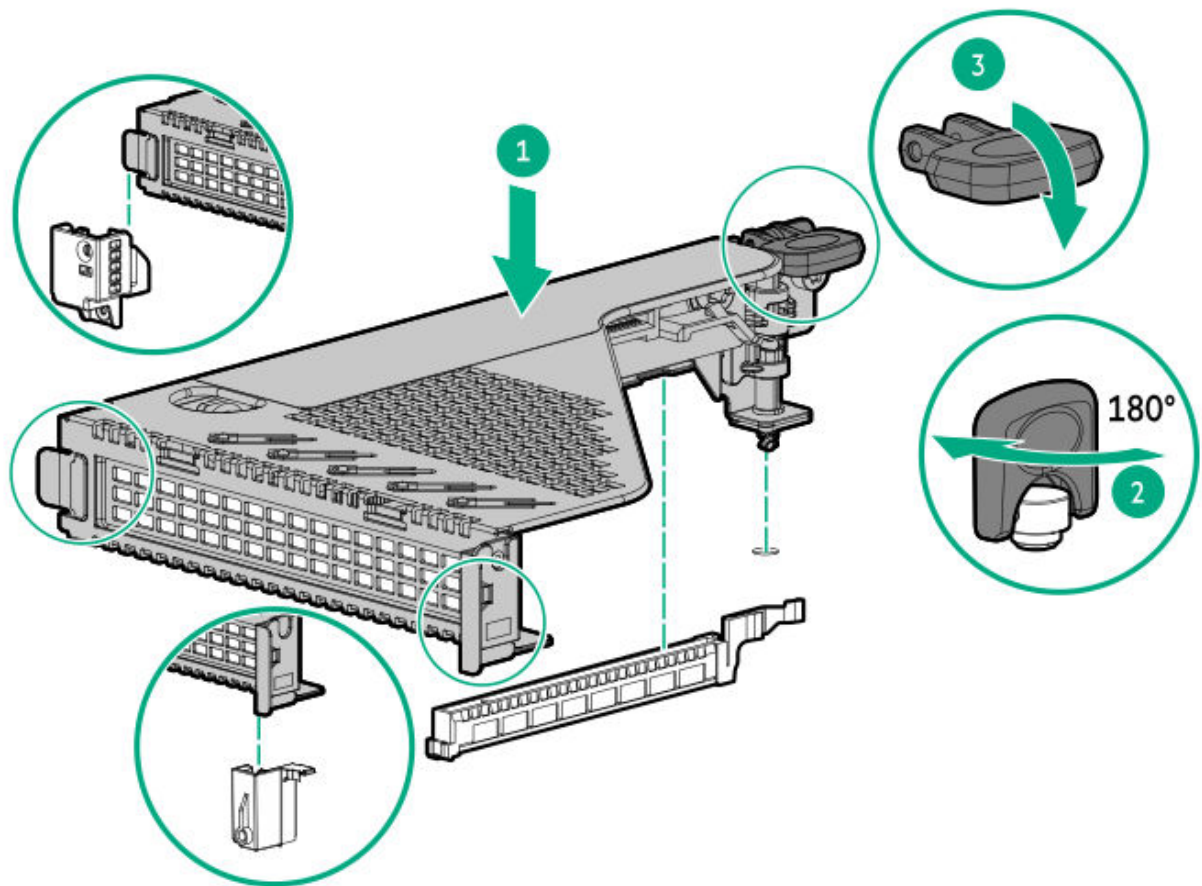

4. To install the GPU riser cage, do the following:

- a. Slide the cage into the slot.
- b. Install the two screws.

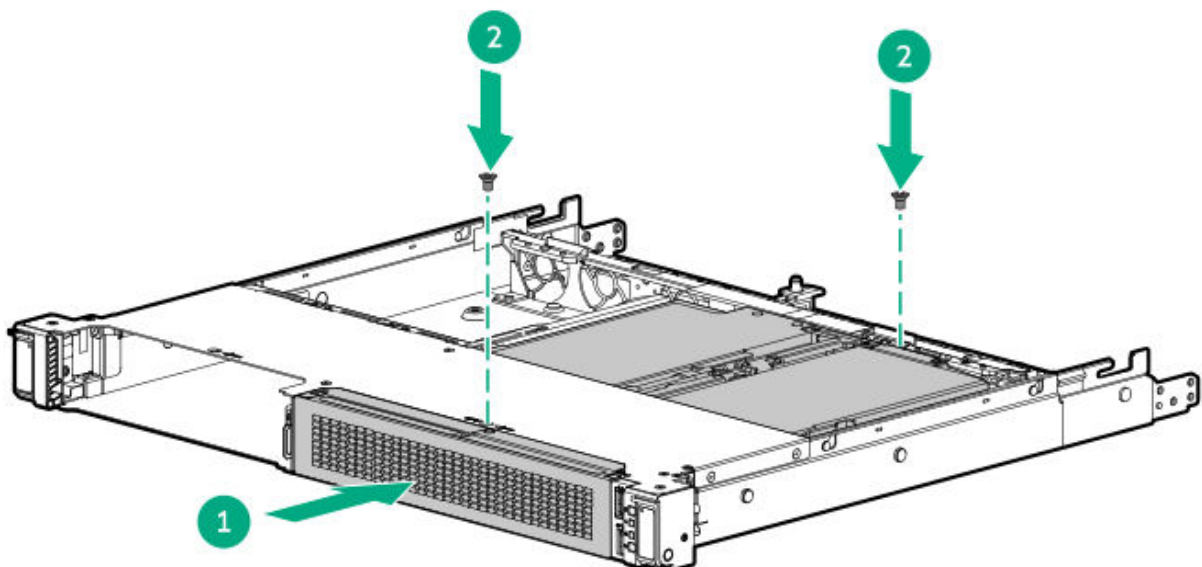

Install the server into the rack

Prerequisites

- Get help to lift and stabilize the server during rack installation. **If the server is installed higher than chest level, additional two people might be required to help install the server:** One person to support the server weight, and the other two to slide the server into the rack.
- Before you perform this procedure, review the:
 - [Rack warnings and cautions](#)
 - [Server warnings and cautions](#)
- A fully populated server is heavy. Hewlett Packard Enterprise recommends removing the external chassis components before installing the server into a rack.

Procedure

1. Extend the slide rails out on the mounting rails until they hit the internal stops and lock into place.

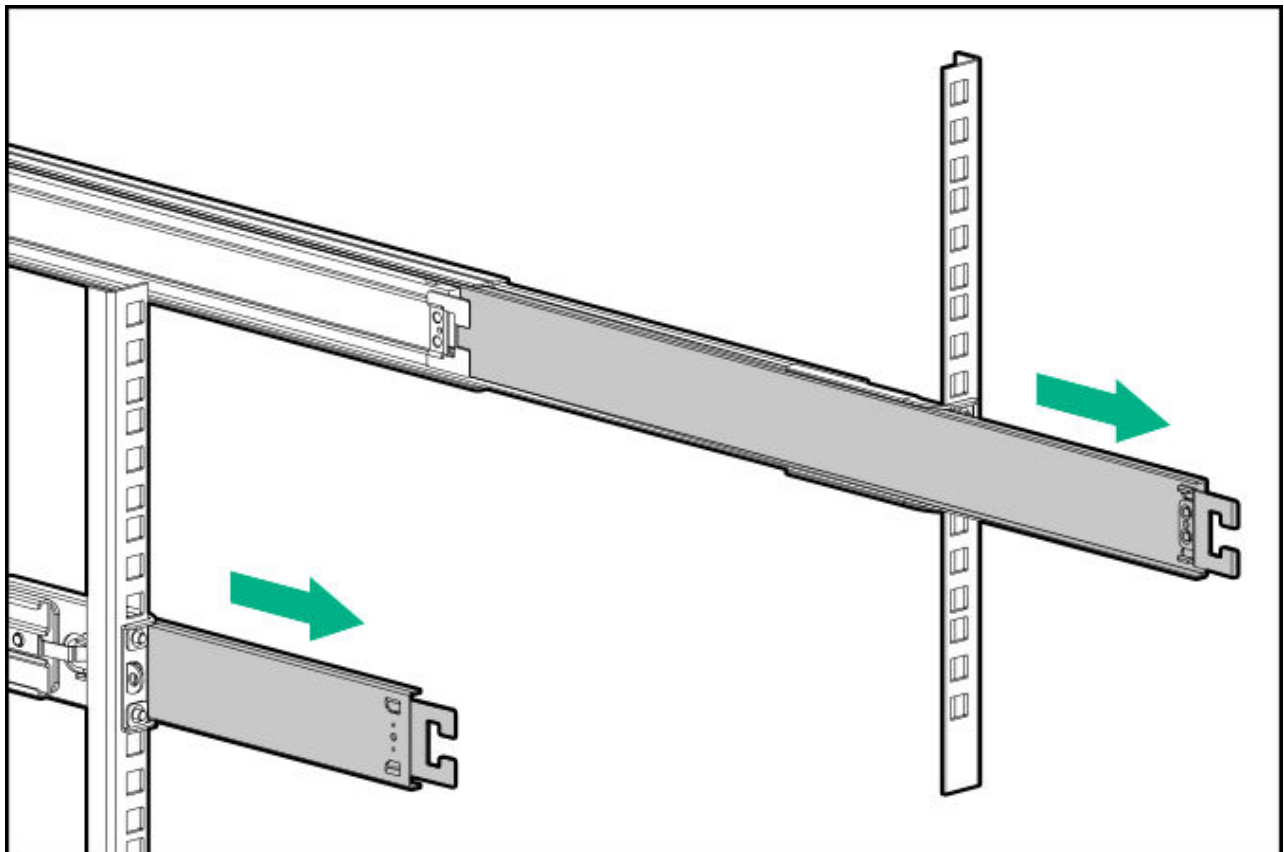

2. Install the server into the rack:
 - a. Insert the inner rails into the slide rails.
 - b. Slide the server into the rack until the chassis ears are flush against the rack posts.

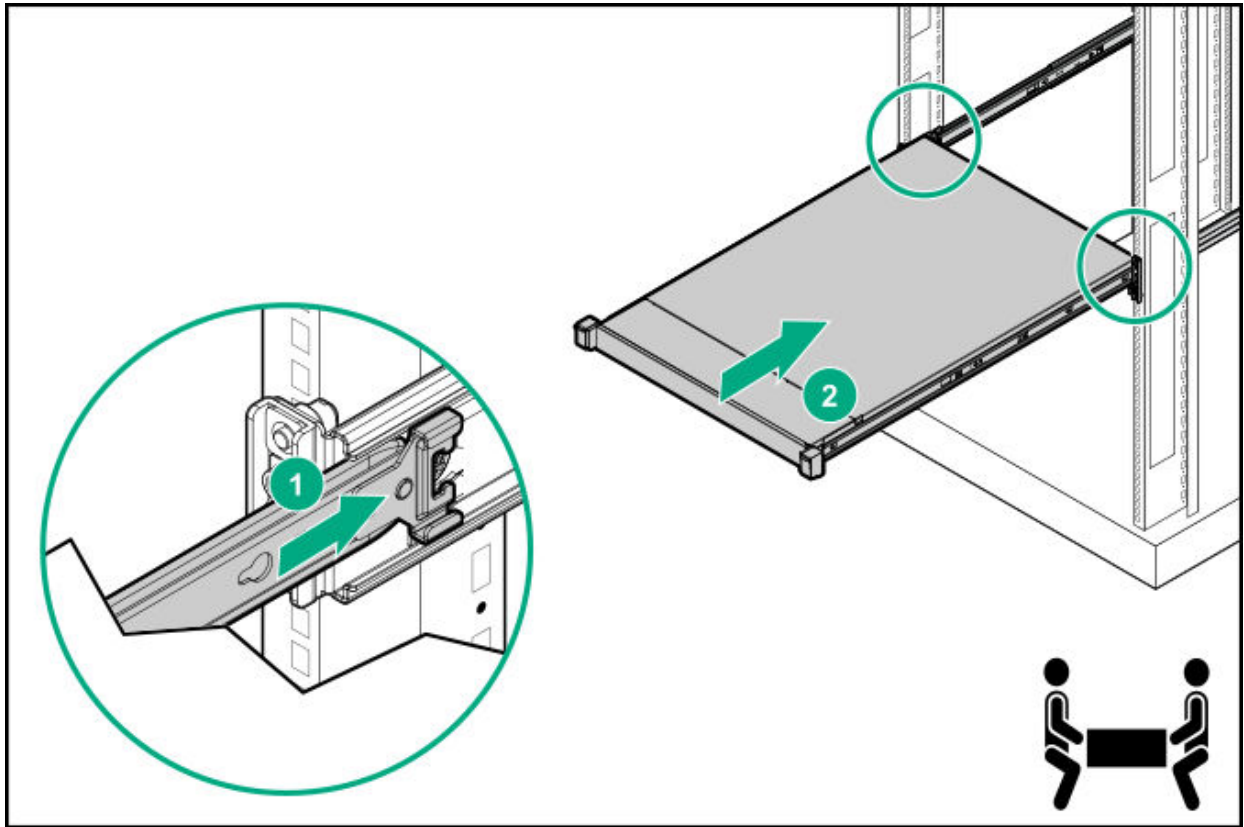

3. Connect all peripheral cables to the server.
4. Connect the power cords:
 - a. Connect each power cord to the server.
 - b. Connect each power cord to the power source.
5. Employ industry best practices in routing and managing the peripheral cables and power cords. Do one of the following:
 - Install the rack rail hoop-and-loop strap.
 - Install the cable management arm.

Hardware options installation

This chapter provides instructions for installing supported hardware options. To ensure proper server deployment and operation, Hewlett Packard Enterprise recommends installing only HPE - validated hardware options. To see the list of validated options for this server, see the product QuickSpecs on the HPE website:

<https://www.hpe.com/info/quickspecs>

To view the warranty for your server and supported options, see [Warranty information](#).

Subtopics

[Server data backup](#)

[Hardware option installation guidelines](#)

[Hewlett Packard Enterprise product QuickSpecs](#)

[Rack mounting options](#)

[Installing the front bezel](#)

[Drive options](#)

[Installing the 8 SFF drive backplane](#)

[Drive cage options](#)

[Optical drive option](#)

[Display port option](#)

[PCIe riser option](#)

[Power supply options](#)

[Transceiver option](#)

[Fan options](#)

[Expansion card options](#)

[GPU options](#)

[Energy pack option](#)

[Memory options](#)

[Storage controller options](#)

[OCP NIC 3.0 option](#)

[HPE NS204i-u Boot Device option](#)

[M.2 SSD options](#)

[Processor heatsink assembly option](#)

[Serial port option](#)

[Chassis intrusion detection switch option](#)

[Internal USB device option](#)

Server data backup

To avoid data loss, make sure to back up all server data before installing or removing a hardware option, performing a server maintenance, or a troubleshooting procedure.

Server data in this context refers to information that may be required to return the system to a normal operating environment after completing a hardware maintenance or troubleshooting procedure. This information may include:

- User data files
- User account names and passwords
- Application settings and passwords
- Component drivers and firmware
- TPM recovery key/password
- BIOS configuration settings—Use the backup and restore function in UEFI System Utilities. For more information, see the UEFI user guide (<https://www.hpe.com/support/hpeuefisystemutilities-quicklinks>).
 - Custom default system settings
 - Security passwords including those required for power-on and BIOS admin access, persistent memory, and Server Configuration Lock (for HPE Trusted Supply Chain servers)
 - Server serial number and the product ID
- iLO-related data—Use the iLO backup and restore function. For more information, see the iLO user guide (<https://www.hpe.com/support/hpeilodocs-quicklinks>).
 - iLO license
 - Customer iLO user name, password, and DNS name
 - iLO configuration settings

Hardware option installation guidelines



WARNING

To reduce the risk of personal injury from hot surfaces, allow the drives and the internal system components to cool before touching them.



CAUTION

To avoid data loss, Hewlett Packard Enterprise recommends that you back up all server data before installing or removing a hardware option, or performing a server maintenance or troubleshooting procedure.



CAUTION

To prevent damage to electrical components, properly ground the server before beginning any installation, removal, or replacement procedure. Improper grounding can cause electrostatic discharge.

- Install any hardware options before initializing the server.
- If multiple options are being installed, read the installation instructions for all the hardware options to identify similar steps and streamline the installation process.
- If the hardware option installation involves internal cabling, review the Cabling guidelines.

Hewlett Packard Enterprise product QuickSpecs

To learn more about your product, search the Hewlett Packard Enterprise website (<https://www.hpe.com/info/quickspecs>) for the product QuickSpecs:

- Supported options
- Supported configurations
- Component compatibility
- New features
- Specifications
- Part numbers

Rack mounting options

Use the quick-deploy, toolless HPE rack rail option to install the server in a standard four-post rack. The rail design supports installation on rack of [different mounting interfaces](#).

For cable management, the rack rail kit might include one or both of the following options:

- [Rack rail hoop-and-loop strap](#)
- [Cable management arm](#)

Subtopics

[Rack mounting interfaces](#)

[Rail identification markers](#)

[Rack rail options](#)

[Installing the rack rail hook-and-loop strap](#)

[Installing the cable management arm](#)

Rack mounting interfaces

The rack rails can be installed in a rack that has the following mounting interfaces:

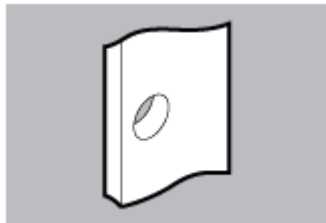

Round-hole

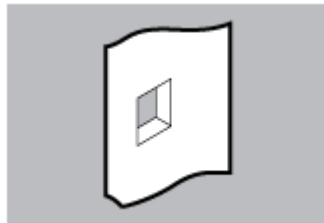

Square-hole

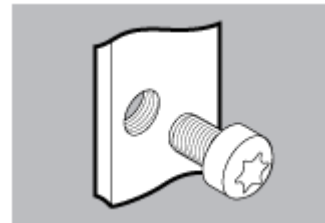

Threaded round-hole

The illustrations used in this procedure show an icon on the upper right corner of the image. This icon indicates the type of mounting interface for which the action illustrated in the image is valid.

Rail identification markers

The rack rail option support is dependent on these two factors:

- The height and weight of the chassis as determined by the front- and rear-end server configurations.

- The depth of the chassis as measured from the edge of the front panel (without the front bezel) to the edge of the rear panel.

To ensure compatibility between the rack rails and the server, verify that the rail number labels on the chassis match the ones stamped on the rails.

- Rail number labels on the chassis

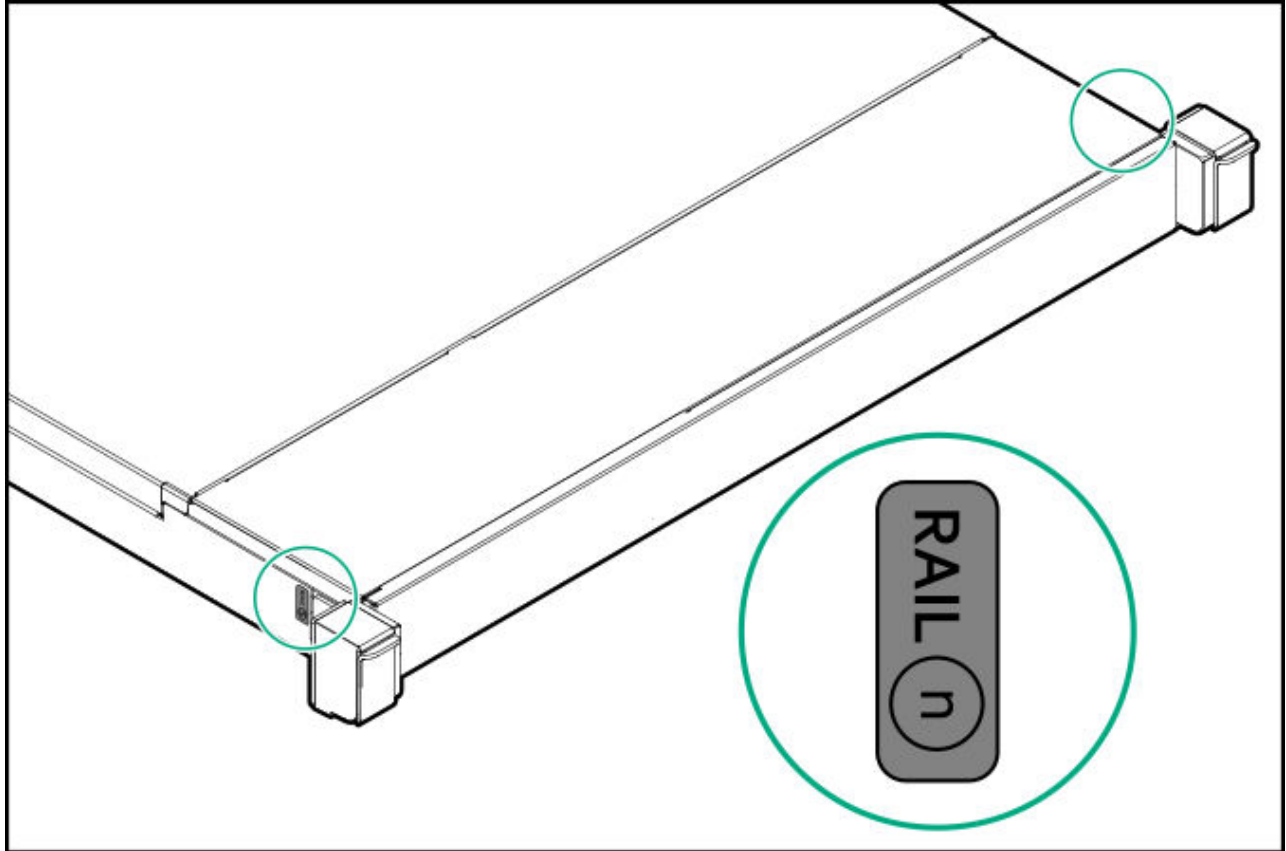

- Rail identifier stamps on the inner rail of the friction rack rail

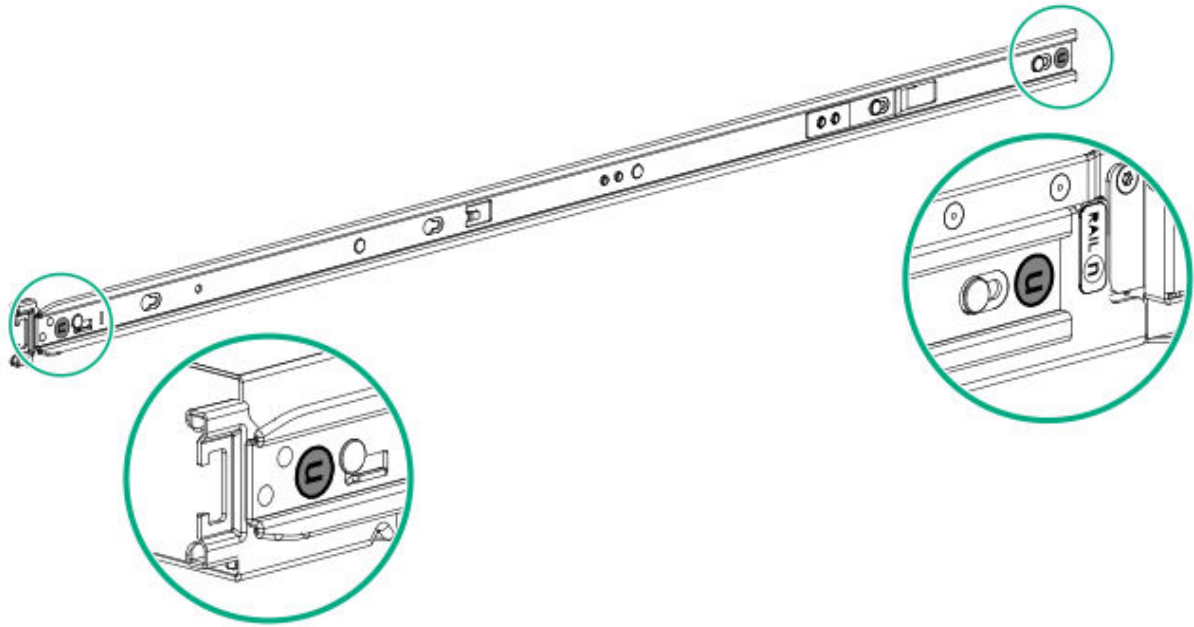

- Rail identifier stamps on the mounting rail of the friction rack rail

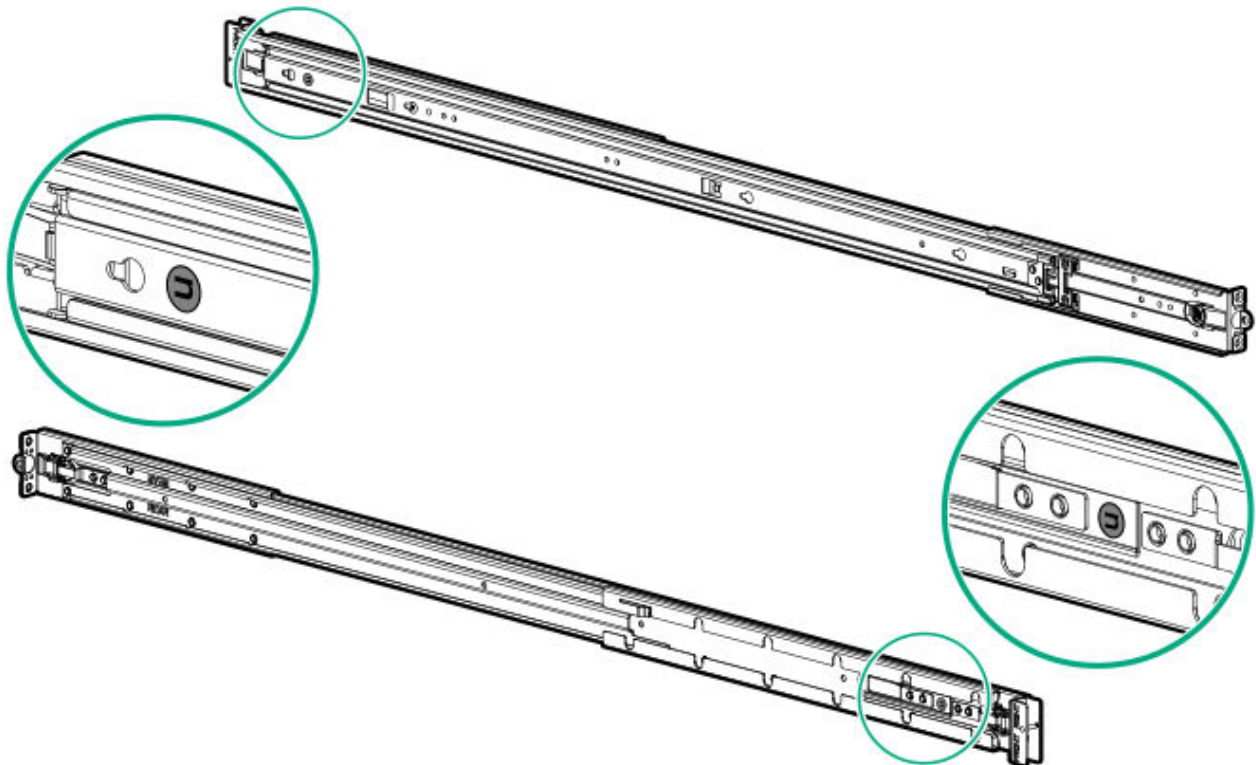

Rack rail options

This server supports the following HPE Easy Install friction rack rail (stab-in) options:

Server configuration	Rack rail option	Minimum rail length	Adjustable rail range
SFF drive	Rail option #1 (P52349-B21)	674.20 mm (26.54 in)	609.60 mm to 867.30 mm (24.00 in to 34.00 in)
LFF drive	Rail option #2 (P52351-B21)	714.32 mm (28.12 in)	609.60 mm to 918.10 mm (24.00 in to 36.15 in)
3-row LFF drive	Rail option #9 (P52353-B21)	1029.61 mm (40.54 in)	609.60 mm to 918.10 mm (24.00 in to 36.15 in)
Accelerator-optimized	Rail option #5 (P52343-B21)	808.69 mm (31.84 in)	609.60 mm to 918.10 mm (24.00 in to 36.15 in)

Subtopics

Installing the rack rail option

Installing the rack rail option

Prerequisites

- [Rail identification markers](#)
- Make sure that the rail option is compatible with the server configuration.
- Small slotted screwdriver—This tool is required if you intend to install the server in a threaded round-hole rack.

Procedure

Installing the inner rails on the server

1. Attach the inner rails to the server:
 - a. Insert the spools on the sides of the server through the keyed slots on the rails.
 - b. Slide the rail towards the rear panel to lock it into place.

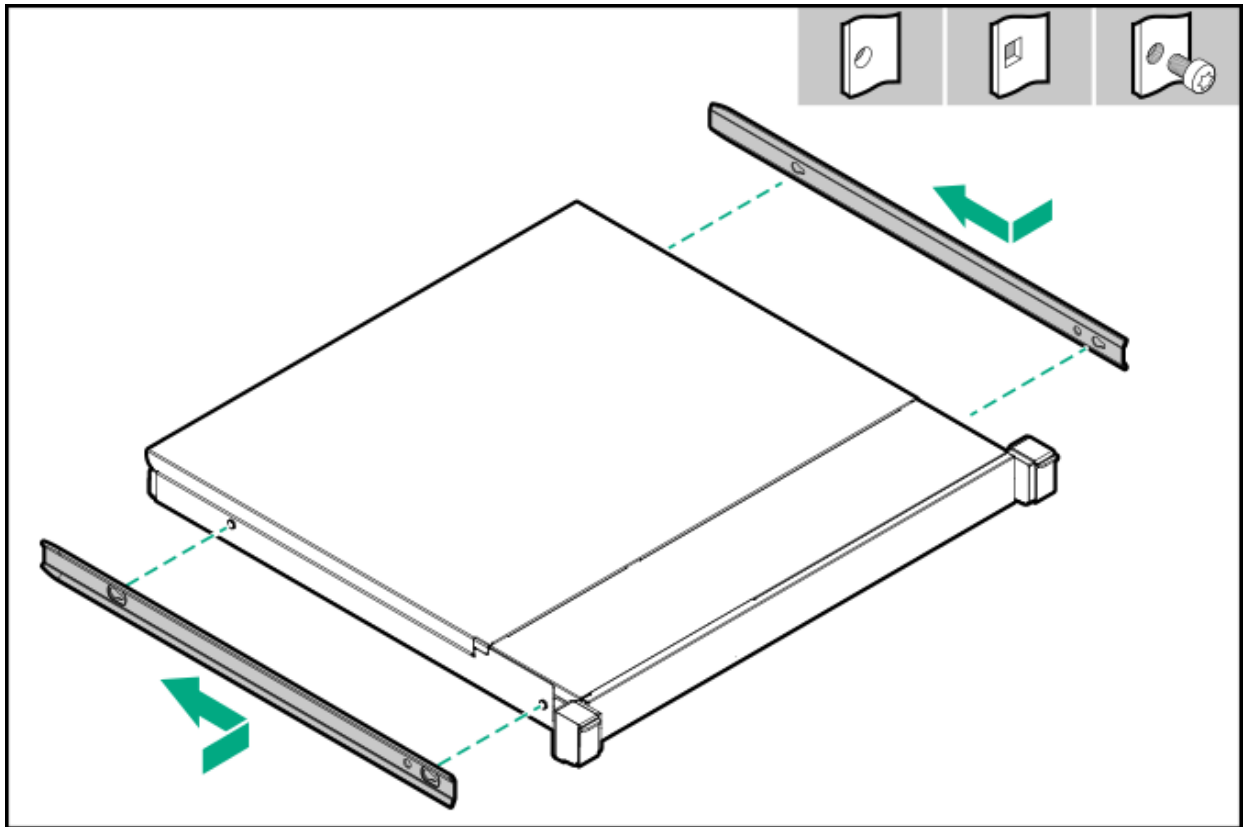

Installing the mounting rails on the rack

2. Locate the orientation markers on the mounting rails.

- The front end of the rails is marked as **FRONT LEFT** or **FRONT RIGHT**.
- The other end of the rails is marked as **REAR**.

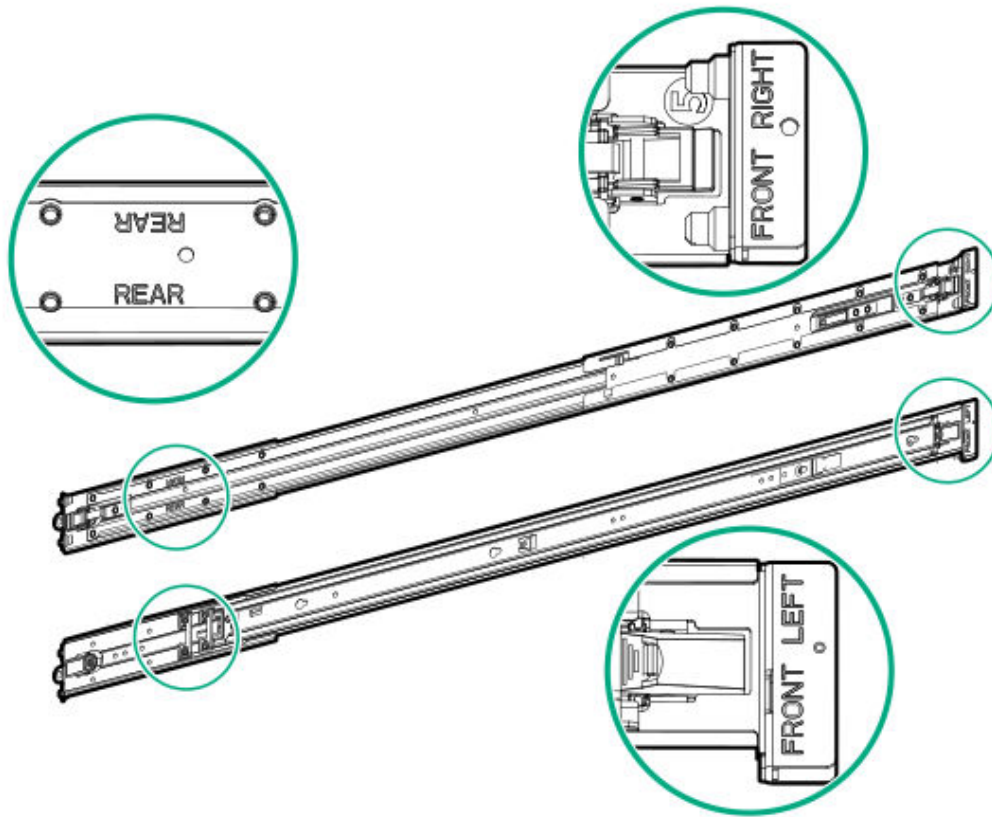

3. Extend the mounting rails to align with the depth of the rack.
4. To install the mounting rails in a round-hole or square-hole rack, insert the pins on the mounting flanges into the rack post holes.

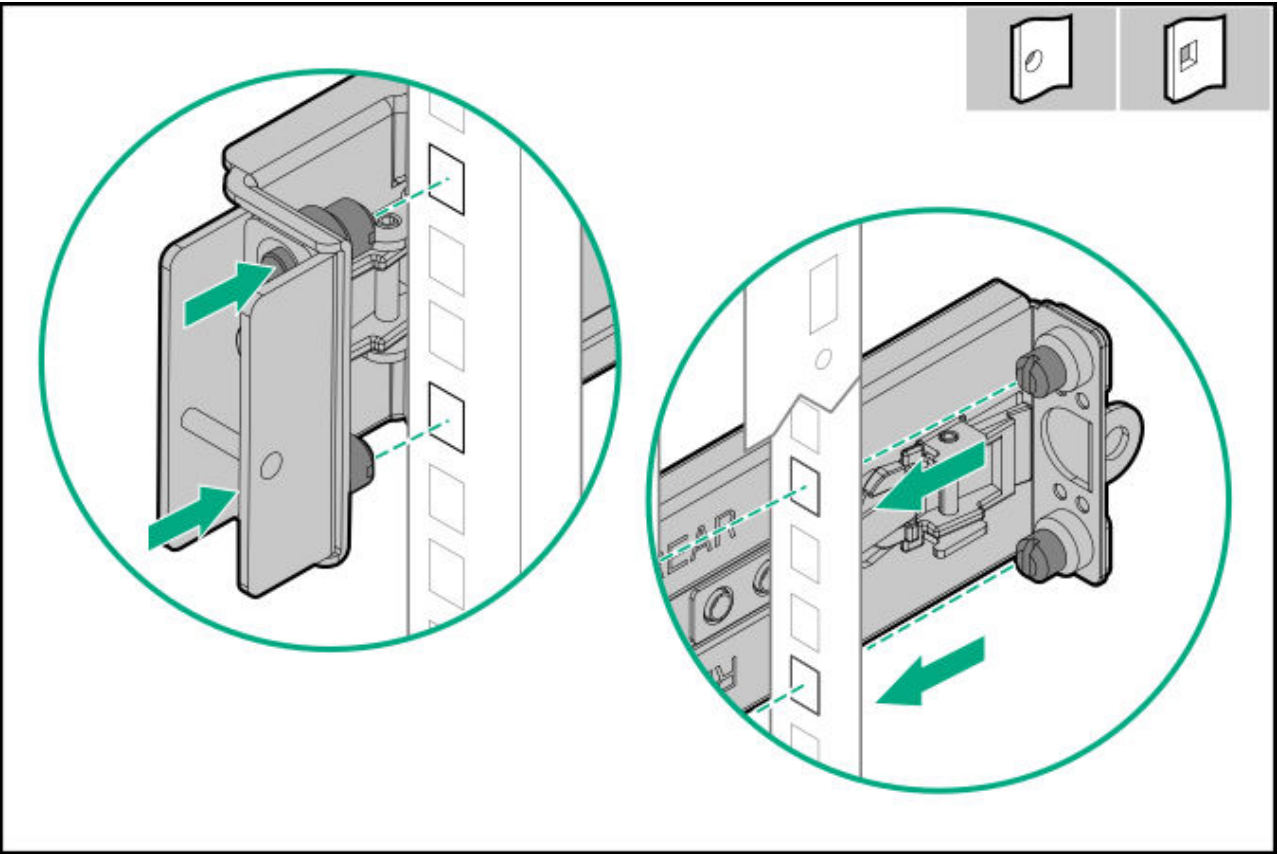

5. To install the mounting rails in a threaded round-hole rack, do the following:
 - a. Remove the pins and washers from the mounting rails.

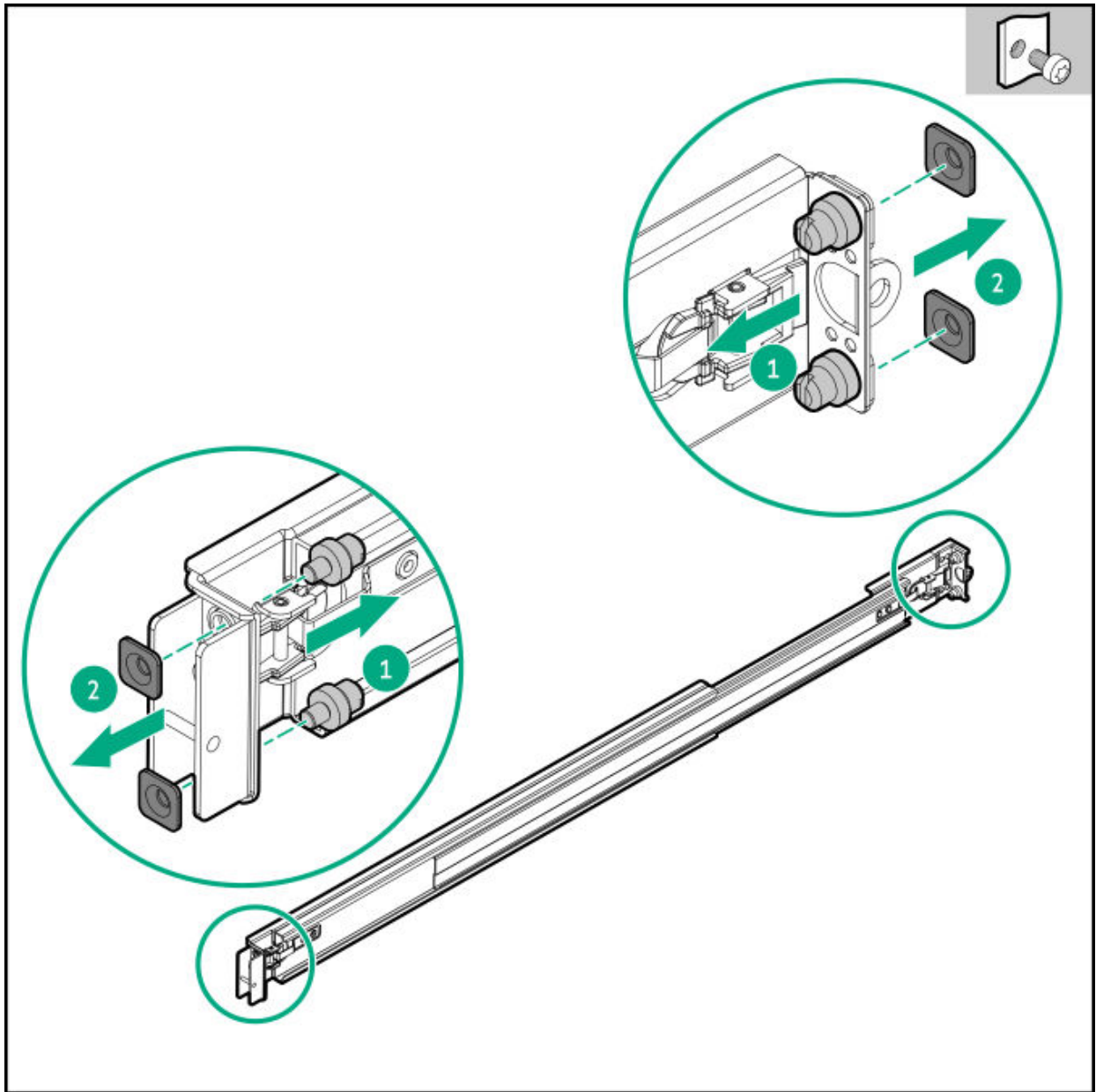

- b. Position the holes on the mounting flanges against the threaded holes on the rack post.
- c. Install the rack mounting screws.

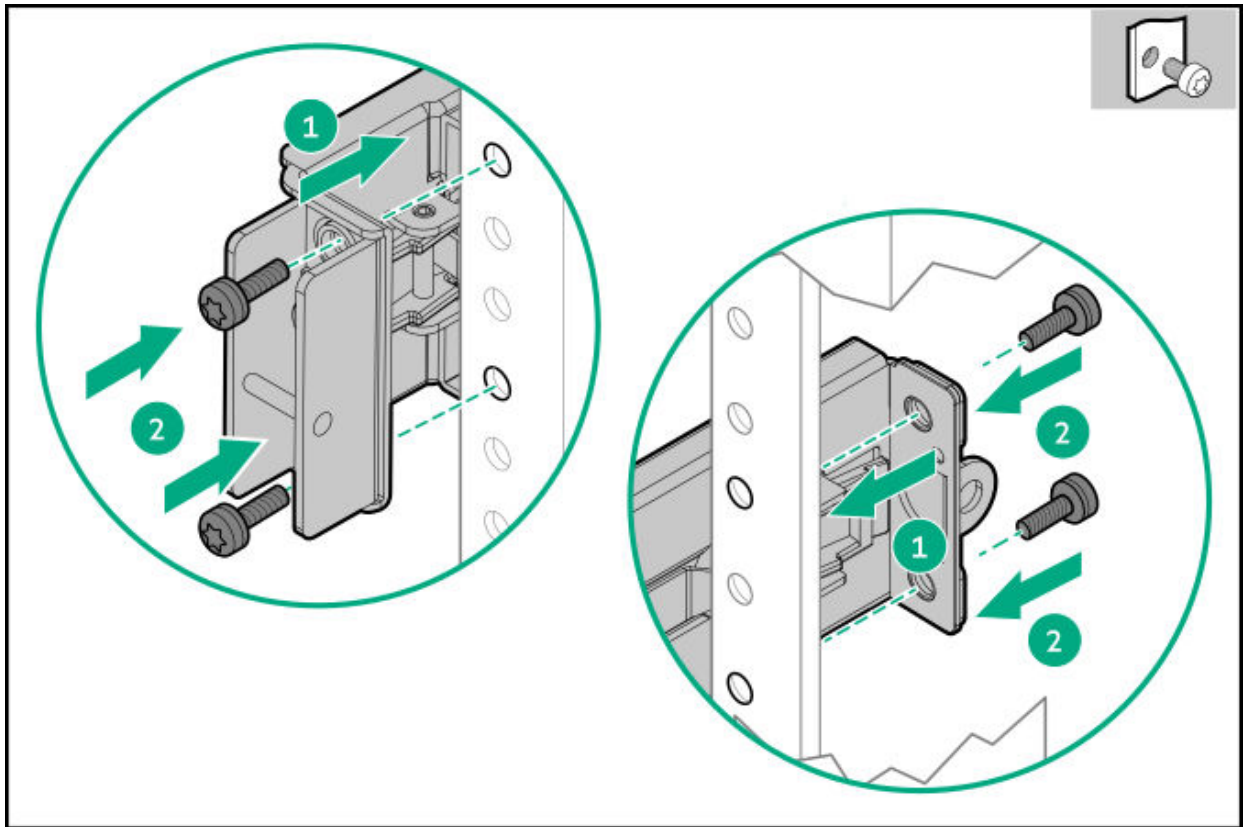

6. Install the server into the rack.

Results

The installation procedure is complete.

Installing the rack rail hook-and-loop strap

About this task

The hook-and-loop strap can be installed on either the left or right rail.

Procedure

1. Attach the strap carabiner to the rail.
2. Bundle the cords and cables, and then wrap the strap around the cables.

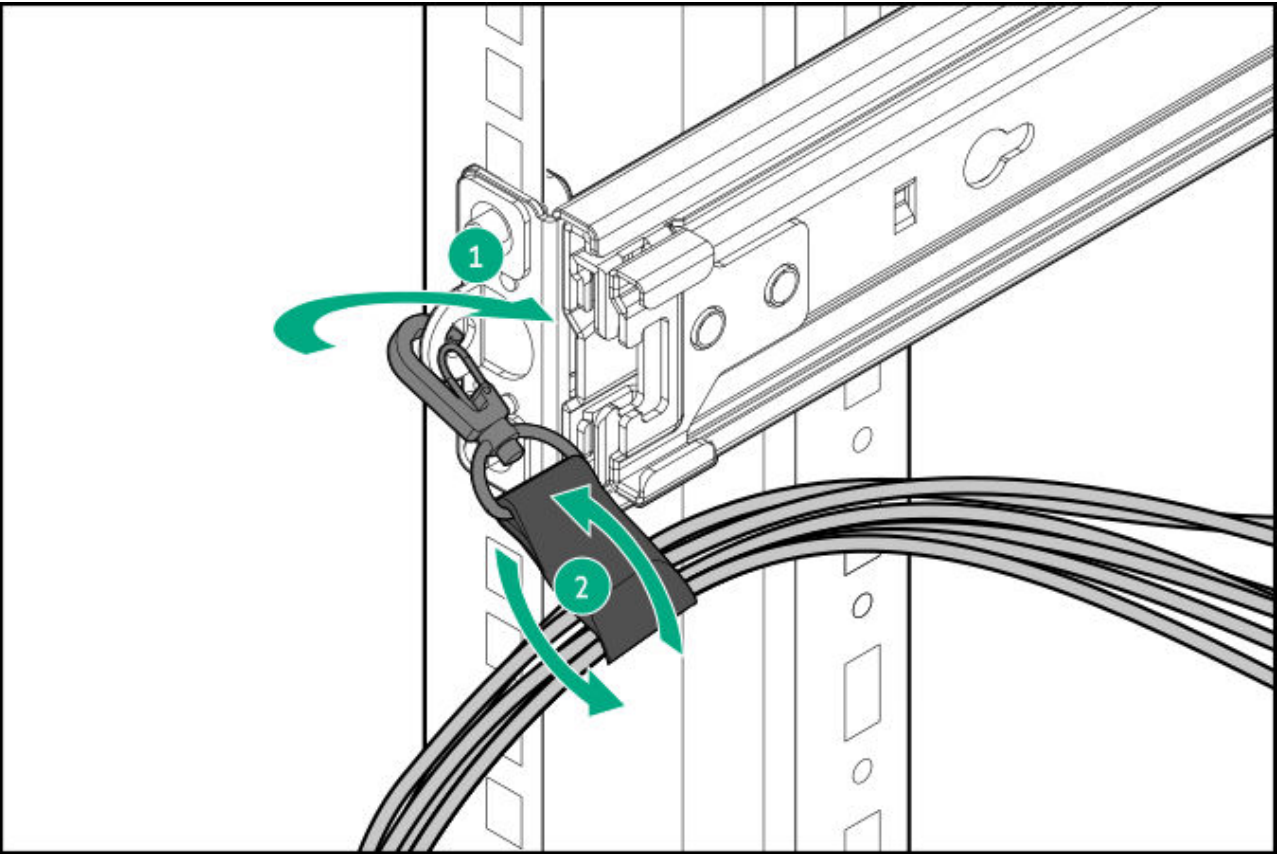

Results

The installation procedure is complete.

Installing the cable management arm

Prerequisites

- Before you perform this procedure, review the [Rack warnings and cautions](#).
- T-25 Torx screwdriver—This tool is required if the shipping screws located inside the chassis ears need to be loosened or tightened.

About this task

The cable management arm (CMA) allows the server to be fully extended from the rack without the need to power off the system or disconnect any rear panel cables. This CMA is designed for ambidextrous implementation.

For the purpose of this procedure, left and right terminology is from the perspective of a user facing the front of the rack.



CAUTION

Support the CMA during the removal and replacement procedures. Do not allow the CMA to hang by its own weight during the procedure.

Procedure

1. Connect and secure all peripheral cables and power cords to the rear panel.
2. (Optional) The CMA retention bracket can be rotated to fit a left- or right-hand CMA operation. Press and hold the rotate mechanism, and then rotate the bracket 180°.

There will be an audible click to indicate that the bracket is locked in its adjusted position.

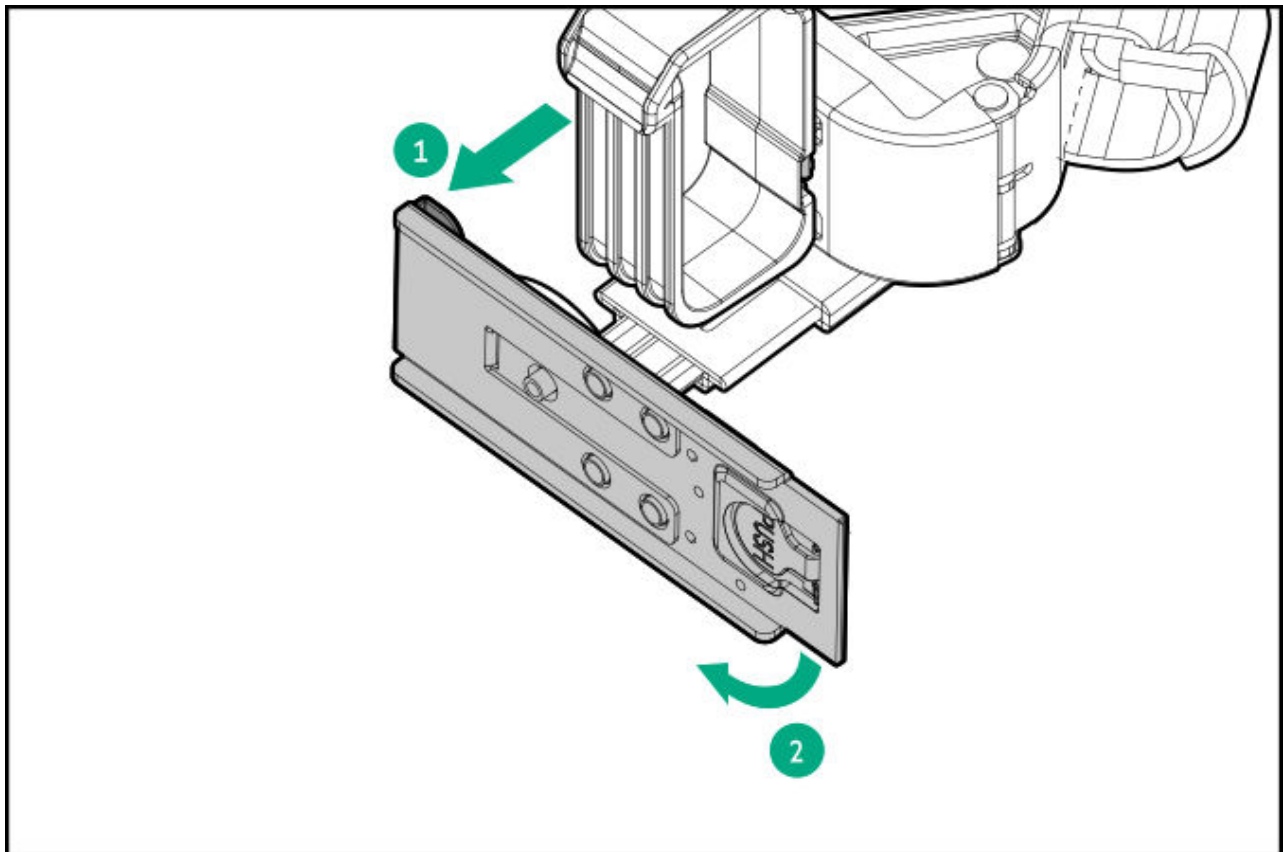

3. Connect the CMA hinged tabs and retention bracket to the rack rails:
 - a. Insert the inner tab into the slide rail.
 - b. Insert the outer tab into the mounting rail.
 - c. Insert the retention bracket into the opposite mounting rail.

There will be an audible click to indicate that the tabs and bracket are locked into place.

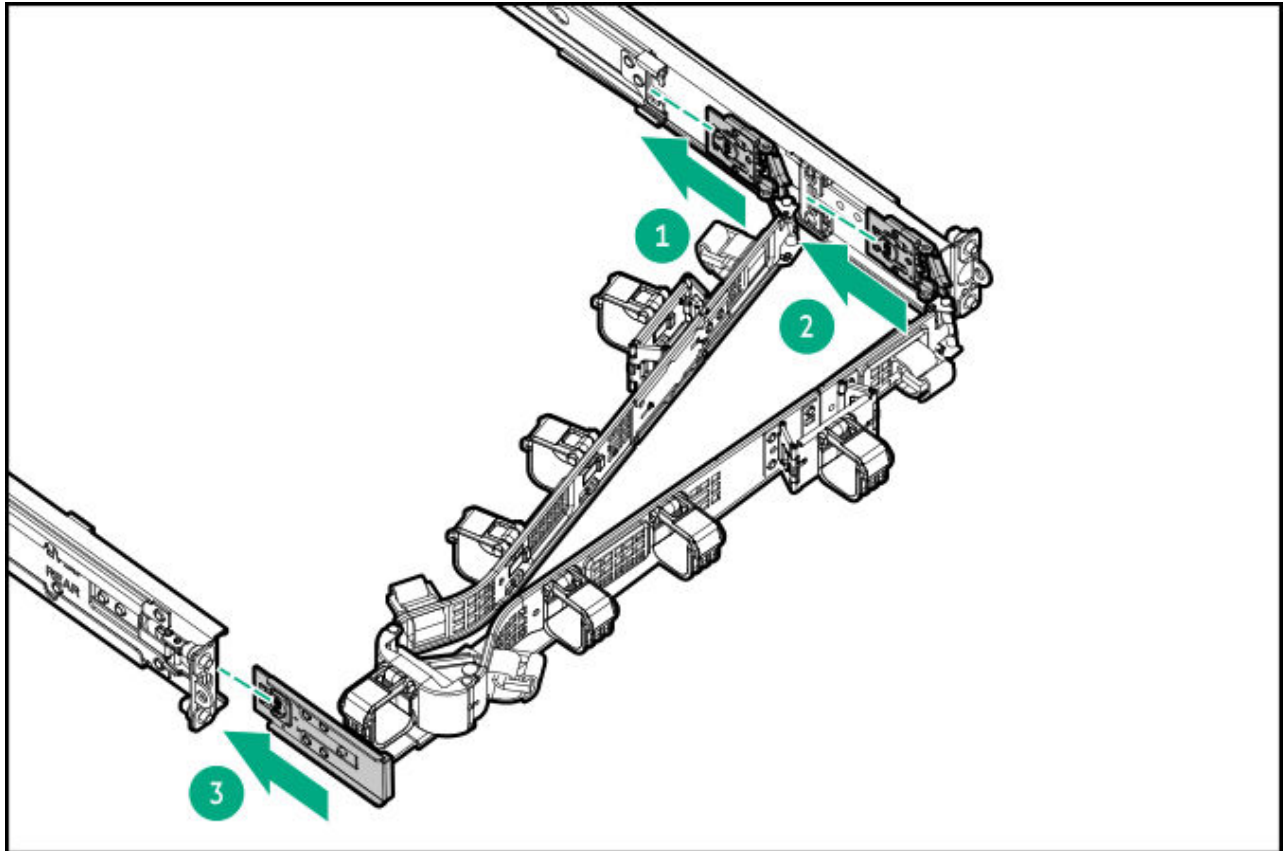

4. Open the cable clamps.

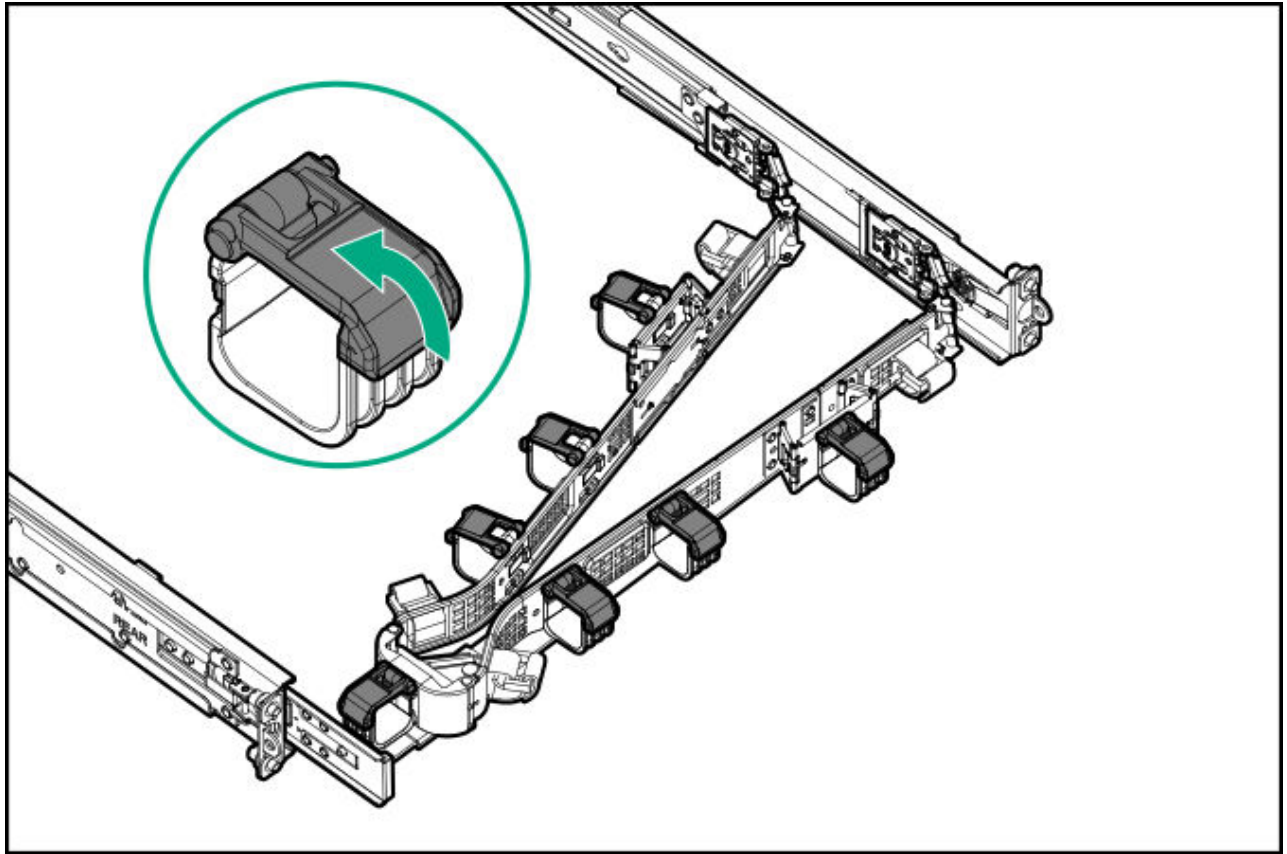

5. (Optional) If your CMA has cable straps for additional cable strain relief, unwrap the straps.

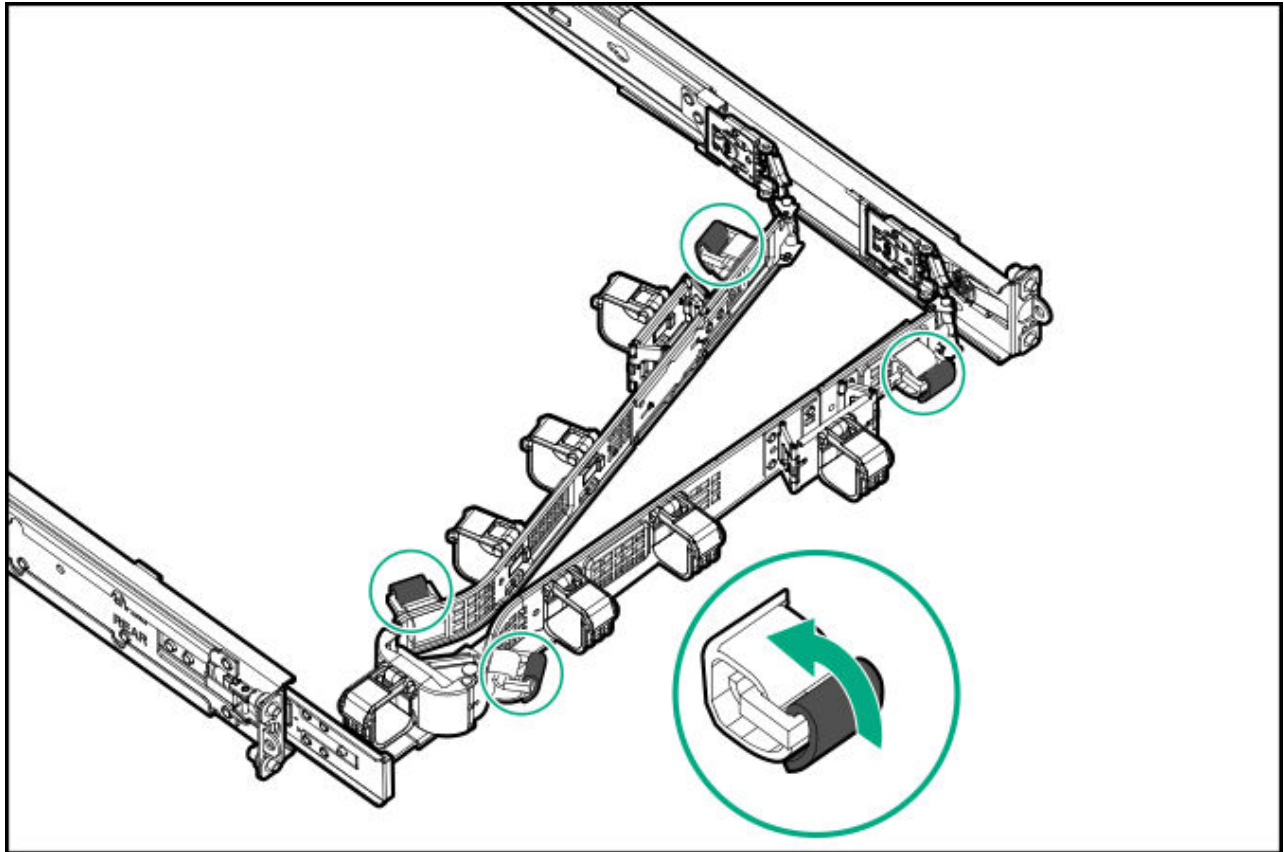

6.



CAUTION

Employ industry best practices in managing peripheral cables and power cords secured in the CMA. These are some of the more important points:

- Leave enough cable slack between the rear panel and the CMA to allow the full extension of the CMA when the server is extended out of the rack.
- However, there should be no excess cable slack inside the CMA; this might cause cable binding and could lead to cable damage.
- Make sure that the cables and power cords do not extend above the top or below the bottom of the server to which they are attached. Otherwise, the cables might snag on other equipment installed in the rack when the server is extended from or returned to the rack.

Route the peripheral cables and power cords through the cable clamps and/or straps.

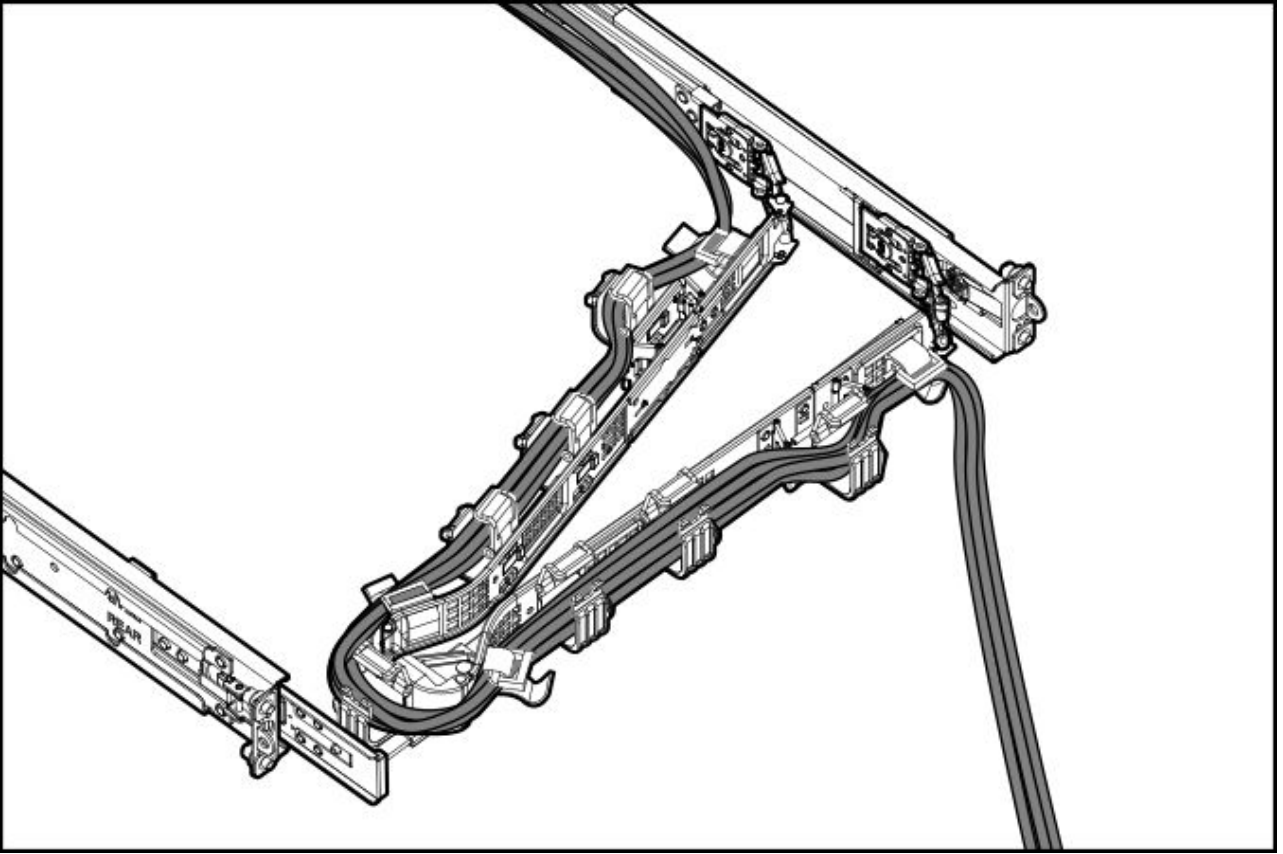

7. Close the cable clamps.

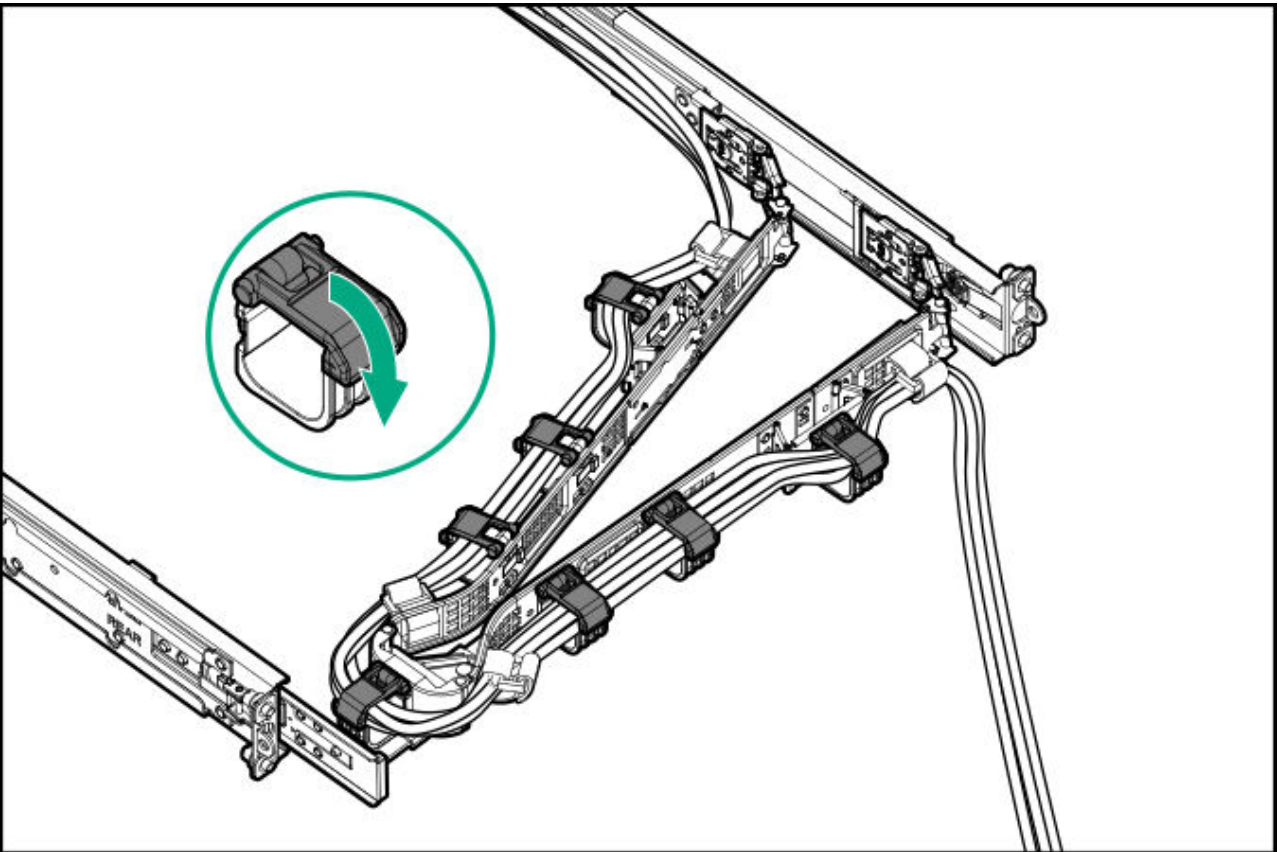

8. (Optional) If your CMA has cable straps, fasten the straps.

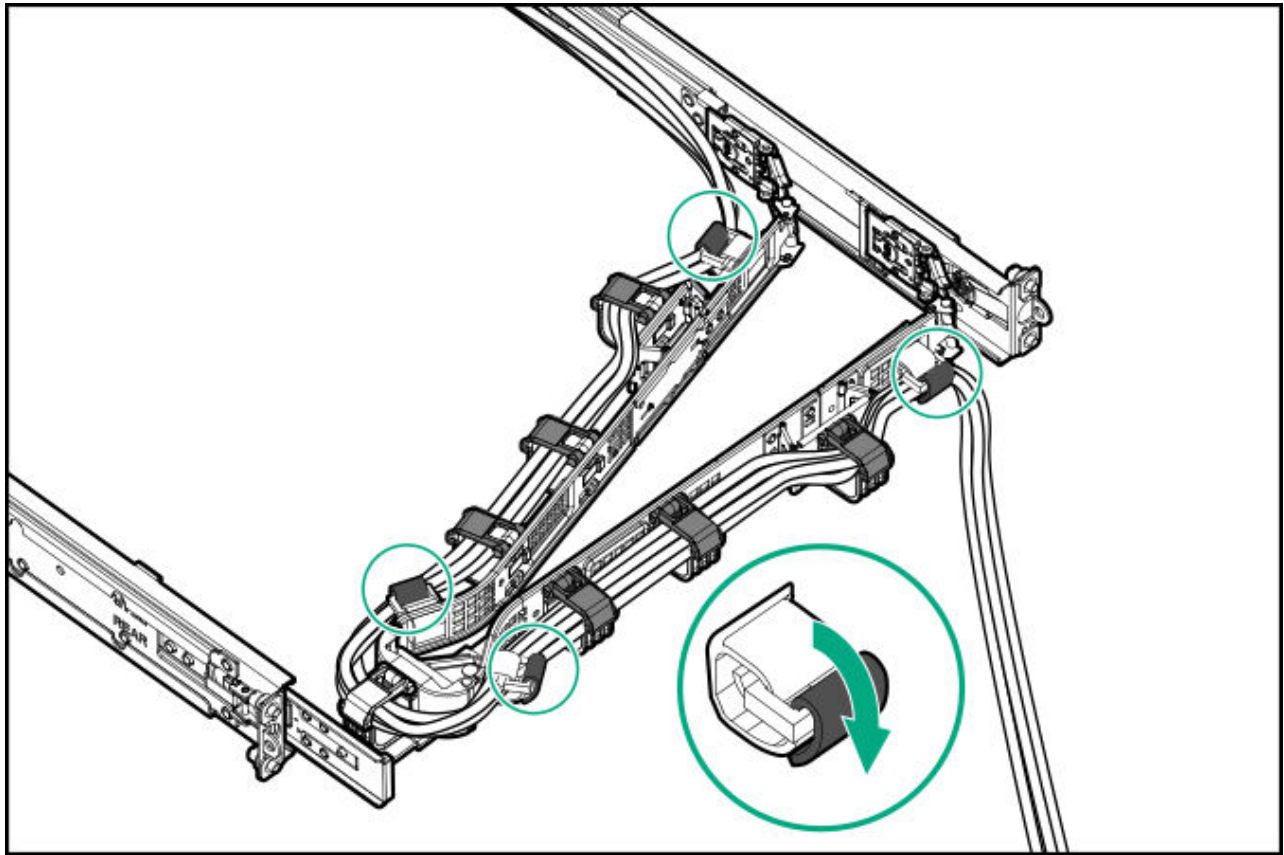

9. Verify the operation of the rack rails:
 - a. Fully extend the chassis out of the rack.
 - b. Check that there is enough slack in the cables and cords for full extension of the chassis. Make sure that there is no cable binding or crimping.
 - c. To ensure that the cables and cords are secured properly, slide the chassis in and out of the rack. Make sure that there is no risk of accidental disconnection of the peripheral cables and power cords.
- .0. Slide the server into the rack until the chassis ears are flushed against the rack posts.
- .1. (Optional) Open the chassis ear latches, and then tighten the shipping screws.

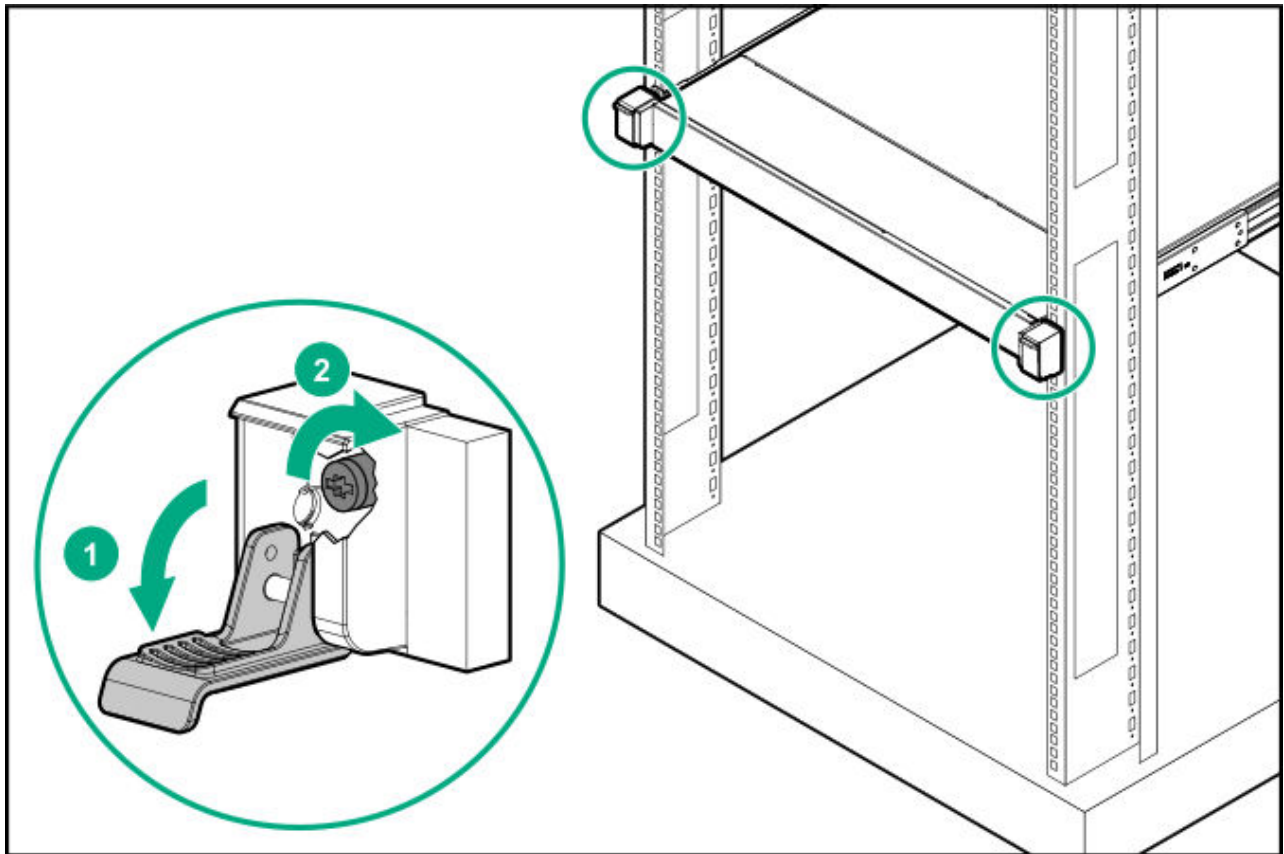

Results

The installation procedure is complete.

Installing the front bezel

Procedure

1. Attach the front bezel to the right chassis ear.
2. Press and hold the front bezel release latch.
3. Close the front bezel.

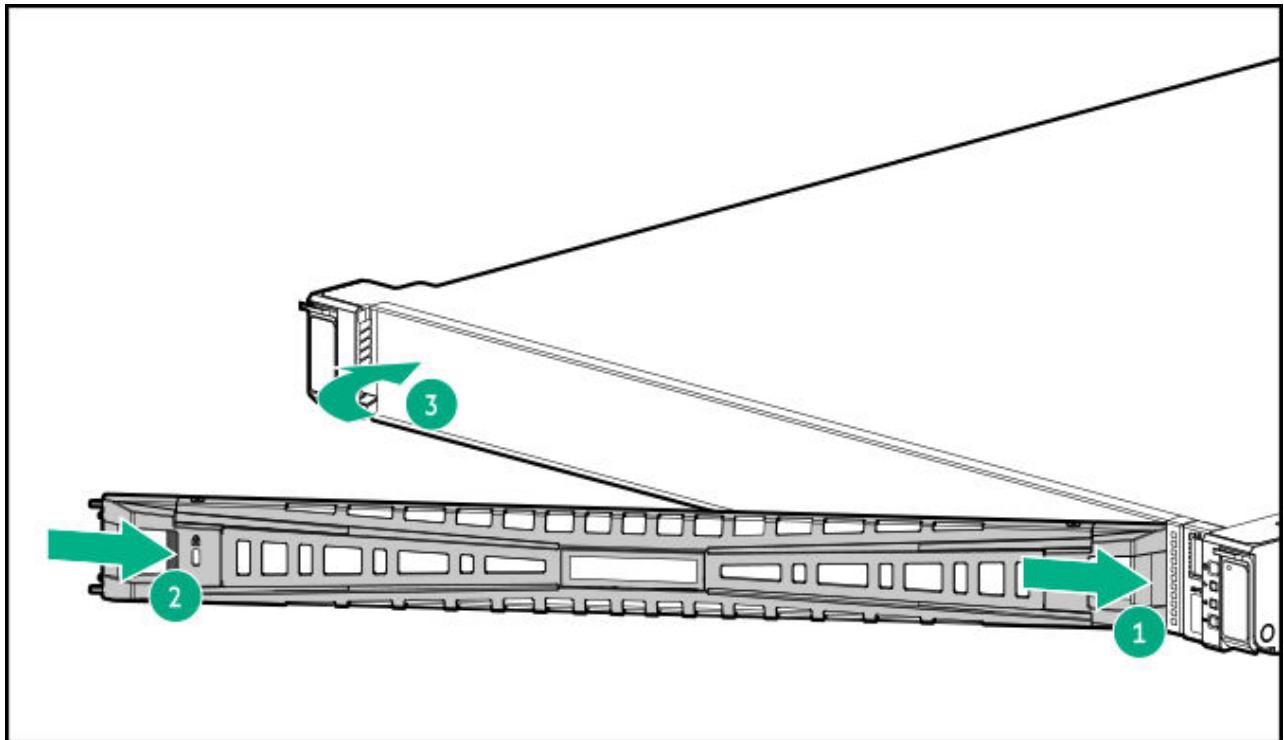

4. (Optional) Install the Kensington security lock.

For more information, see the lock documentation.

Drive options

Depending on the drive backplane installed, the server supports the following drive types:

- Hot-plug LFF hot-plug, SAS, and SATA
- Hot-plug SFF SAS, SATA, NVMe
- Hot-plug E3.S PCIe5 NVMe SSDs

The embedded Intel VROC for HPE Gen11 (Intel VROC) supports software RAID for direct attached SATA and NVMe drives.

To support hardware RAID, [install a storage controller option.](#)

Subtopics

Drive installation guidelines

Installing a hot-plug SAS, SATA or NVMe drive

Installing a hot-plug drive in box three or box five

Installing an E3.S drive

Drive installation guidelines

Observe the following general guidelines:

- The system automatically sets all drive numbers.



CAUTION

When a server is purchased without any drive installed, some drive bays might be empty while other drive bays might be populated with drive blanks. To maintain proper system cooling, do not operate the server without a drive or a drive blank installed.

- If only one drive is used, install it in the bay with the lowest drive number. For drive numbering, see [Drive bay numbering](#).
- This server does not support mixed drive types in the same drive box.
- All drives grouped into the same drive array must meet the following criteria:
 - All drives must be either all hard drives or all solid-state drives.
 - All drives must be of the same capacity to provide the greatest storage space efficiency when drives are grouped into the same drive array.

Installing a hot-plug SAS, SATA or NVMe drive

About this task



CAUTION

To maintain proper system cooling, do not operate the server for long period with the access panel open or removed. Operating the server in this manner results in an improper system airflow. For internal hot-plug component procedures, complete the procedure within 60 seconds. Failure to do so can cause the system temperature to increase and trip the safety threshold. When this happens:

- The health LED flashes amber.
- The operating system gracefully shuts down.



CAUTION

A discharge of static electricity from a finger or other conductor might damage system boards or other static-sensitive devices. To prevent damage, observe antistatic precautions.



CAUTION

To prevent improper cooling and thermal damage, do not operate the server unless all bays are populated with either a component or a blank.

Procedure

1. If installed, remove the front bezel.
2. Remove the drive blank.

Retain the blank for future use.

- LFF drive blank

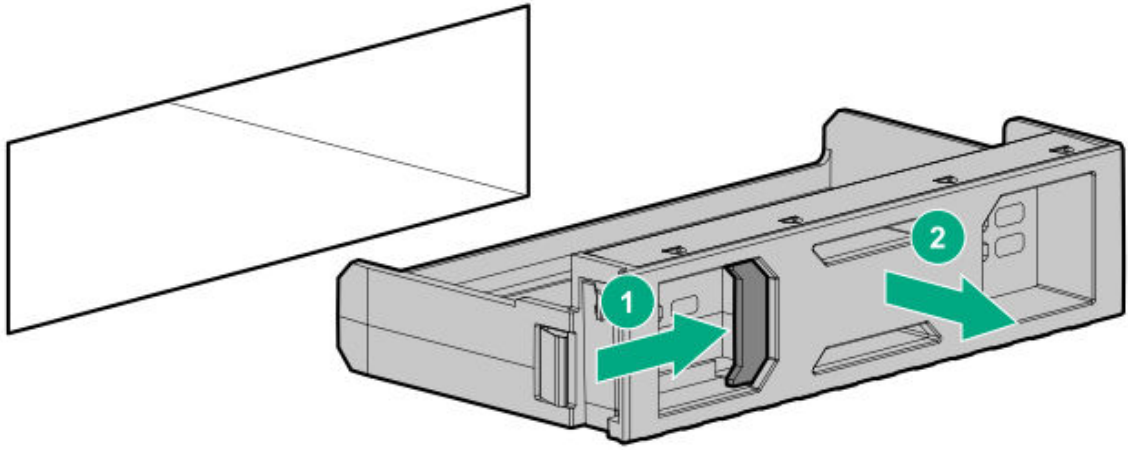

- SFF drive blank

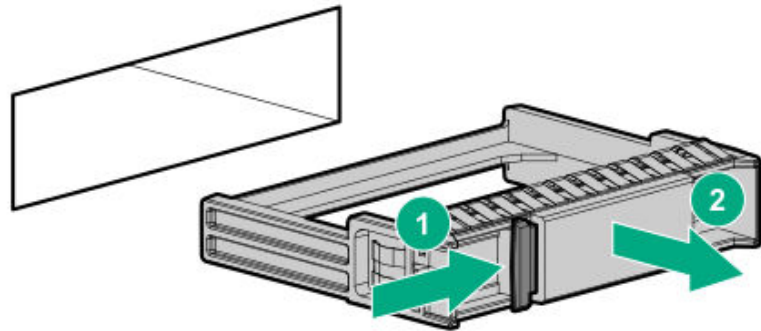

3. Prepare the drive.

- LFF drive

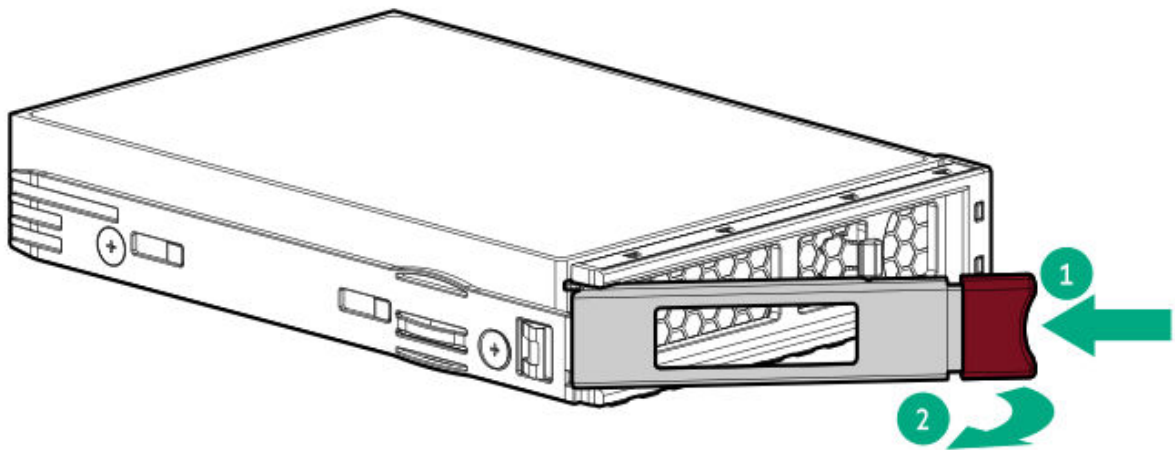

- SFF drive

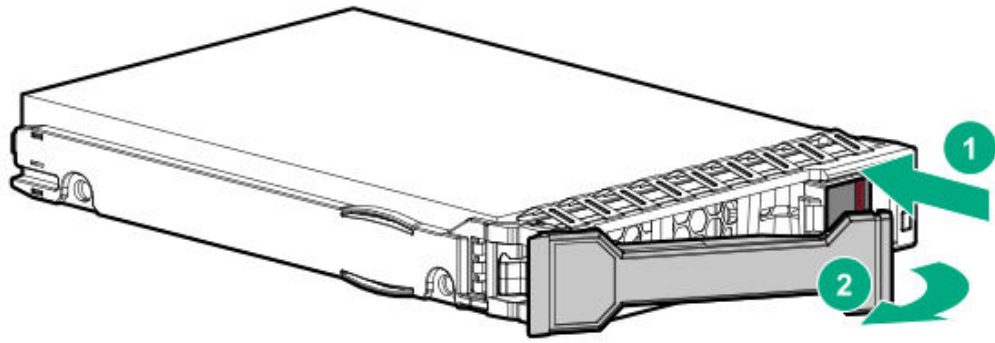

4. Install the drive.

- LFF drive

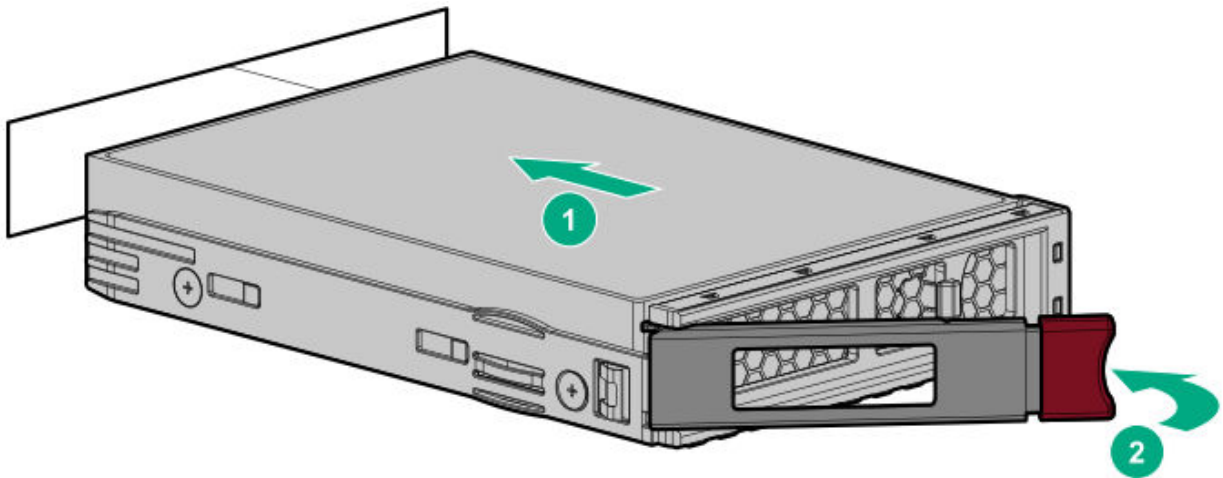

- SFF drive

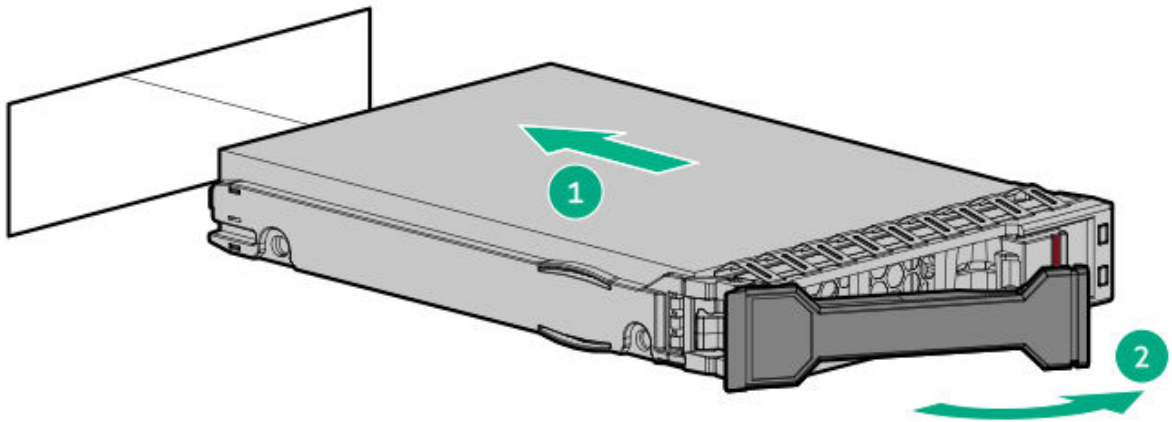

5. Determine the status of the drive from the drive LED definitions.

6. If removed, install the front bezel.
7. Configure the controller.

Results

The installation procedure is complete.

Installing a hot-plug drive in box three or box five

About this task



CAUTION

To maintain proper system cooling, do not operate the server for long period with the access panel open or removed. Operating the server in this manner results in an improper system airflow. For internal hot-plug component procedures, complete the procedure within 60 seconds. Failure to do so can cause the system temperature to increase and trip the safety threshold. When this happens:

- The health LED flashes amber.
- The operating system gracefully shuts down.



CAUTION

A discharge of static electricity from a finger or other conductor might damage system boards or other static-sensitive devices. To prevent damage, observe antistatic precautions.



CAUTION

To prevent improper cooling and thermal damage, do not operate the server unless all bays are populated with either a component or a blank.

Procedure

1. If installed, open the cable management arm.
2. Do one of the following:
 - a. Extend the server from the rack.
 - b. Remove the server from the rack.

3. Press and pull the tab.

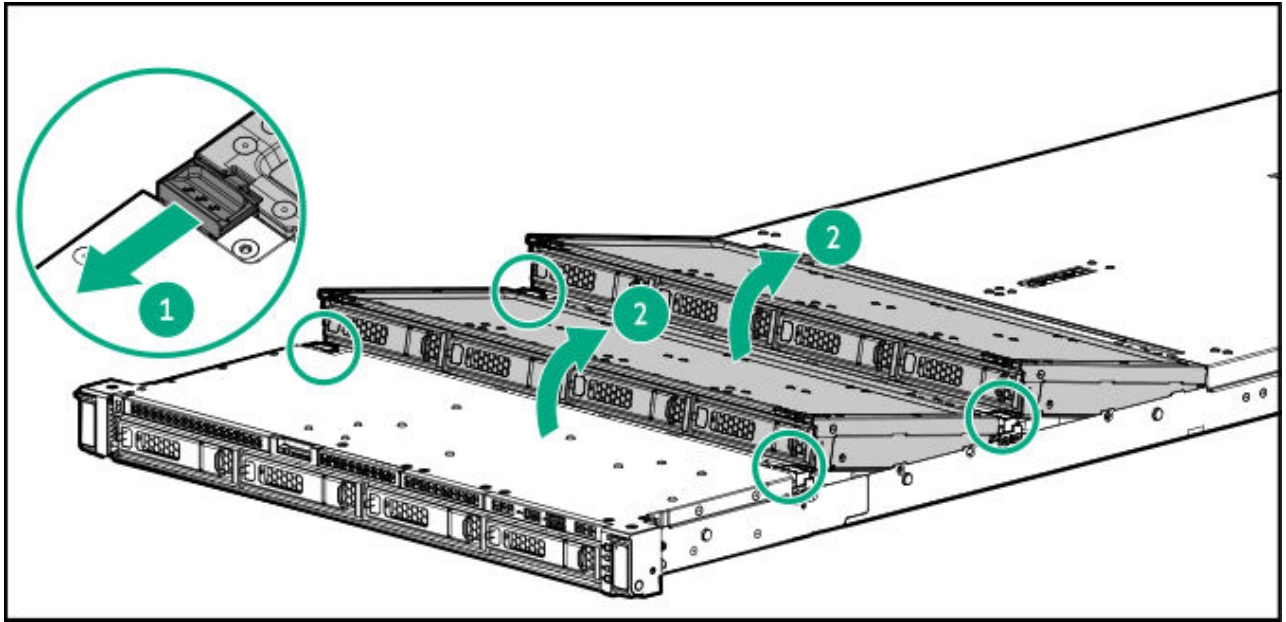

4. Remove the drive blank.

Retain the blank for future use.

- LFF drive blank

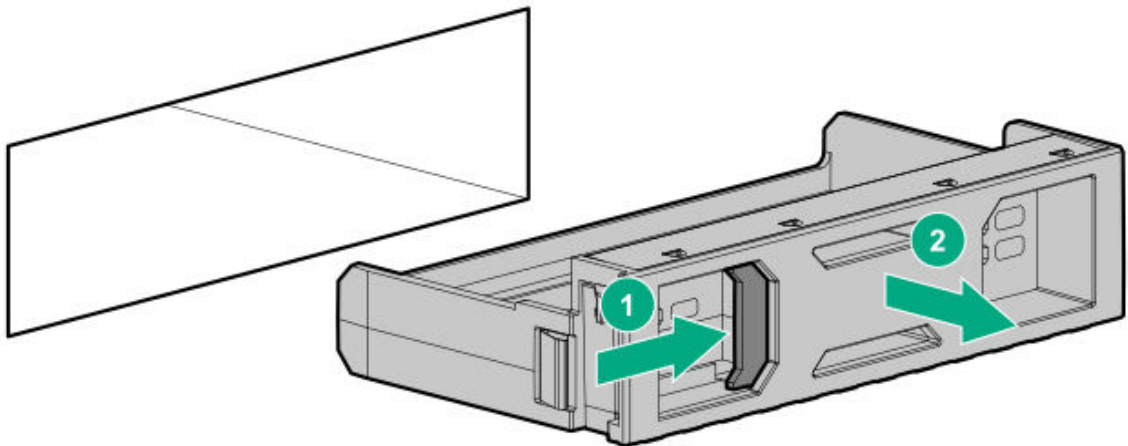

- SFF drive blank

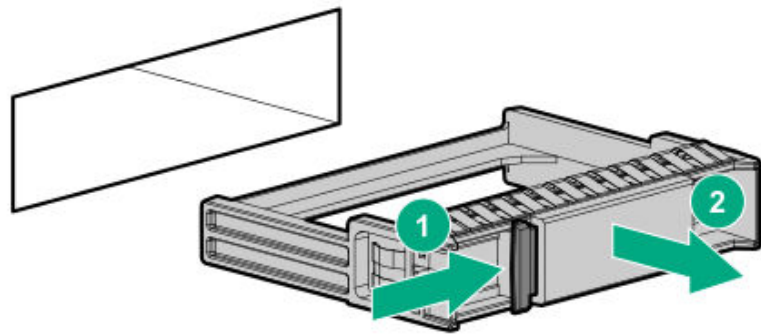

5. Prepare the drive.

- LFF drive

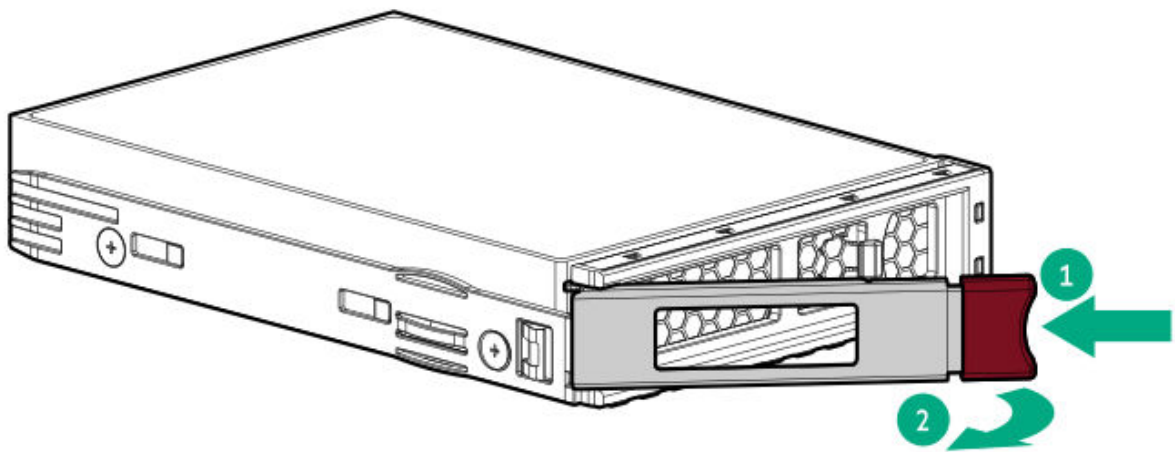

- SFF drive

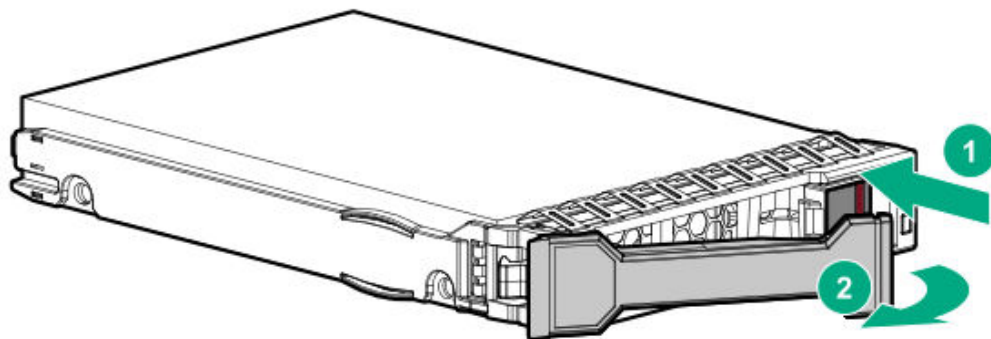

6. Install the drive.

- LFF drive

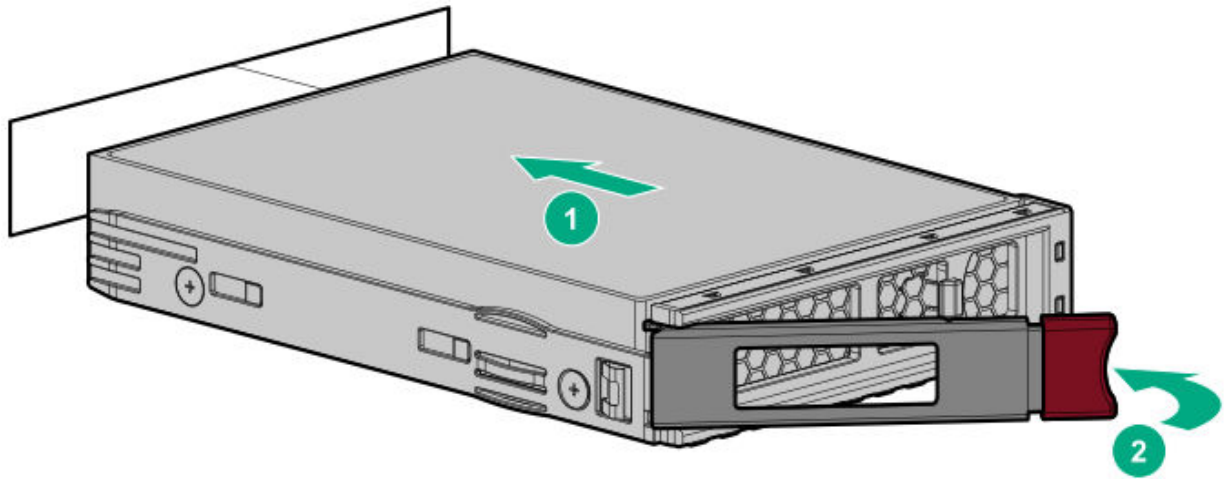

- SFF drive

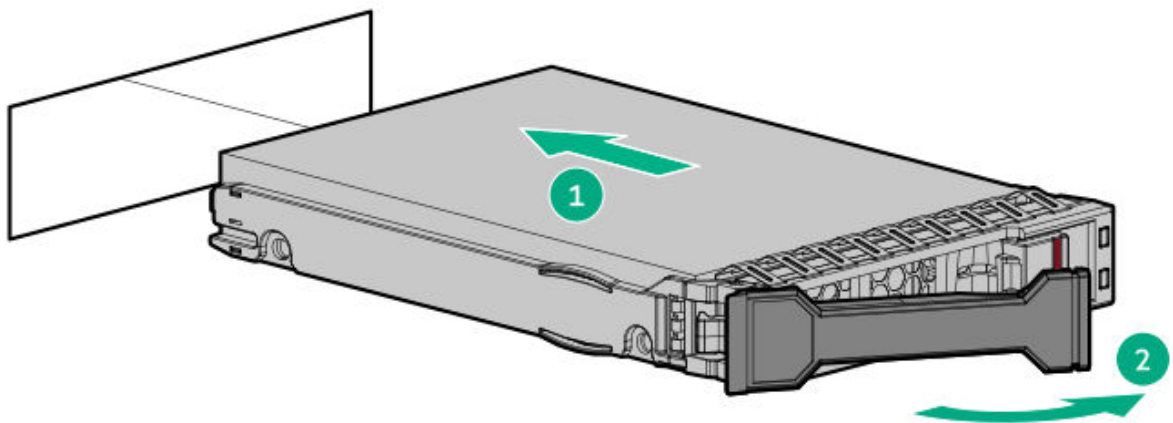

7. Determine the status of the drive from the drive LED definitions.
8. To configure drive arrays, see the relevant storage controller guide.

Results

The installation procedure is complete.

Installing an E3.S drive

About this task



CAUTION

A discharge of static electricity from a finger or other conductor might damage system boards or other static-sensitive devices. To prevent damage, observe antistatic precautions.



CAUTION

To prevent improper cooling and thermal damage, do not operate the server unless all bays are populated with either a component or a blank.

Procedure

1. Back up all server data.
2. If installed, remove the front bezel.
3. Remove the drive blank.

Retain the blank for future use.

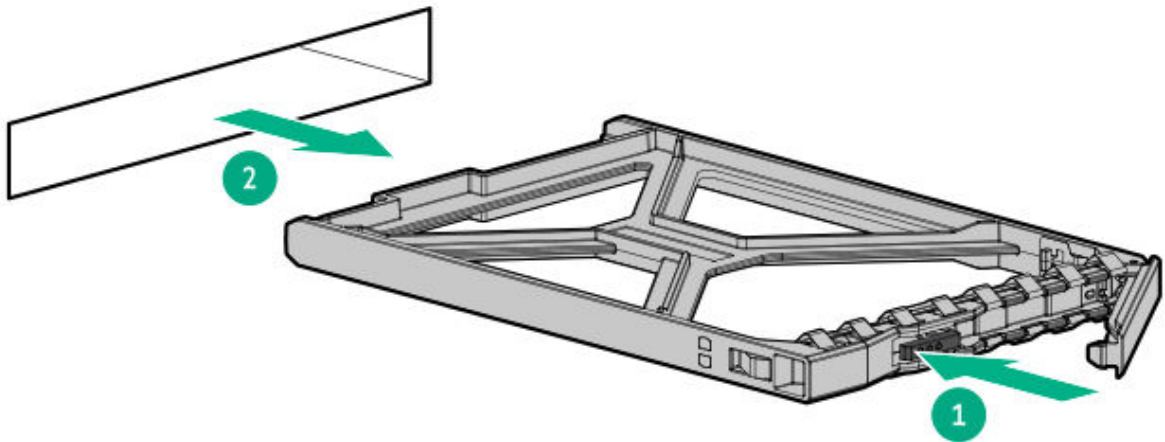

4. Prepare the drive.

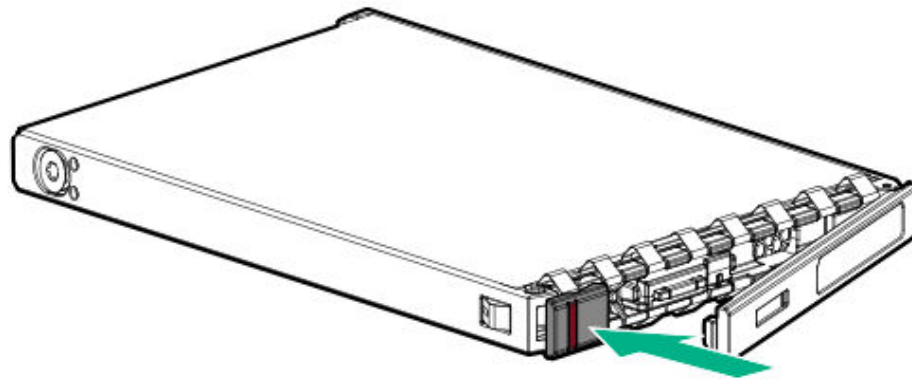

5. Install the drive.

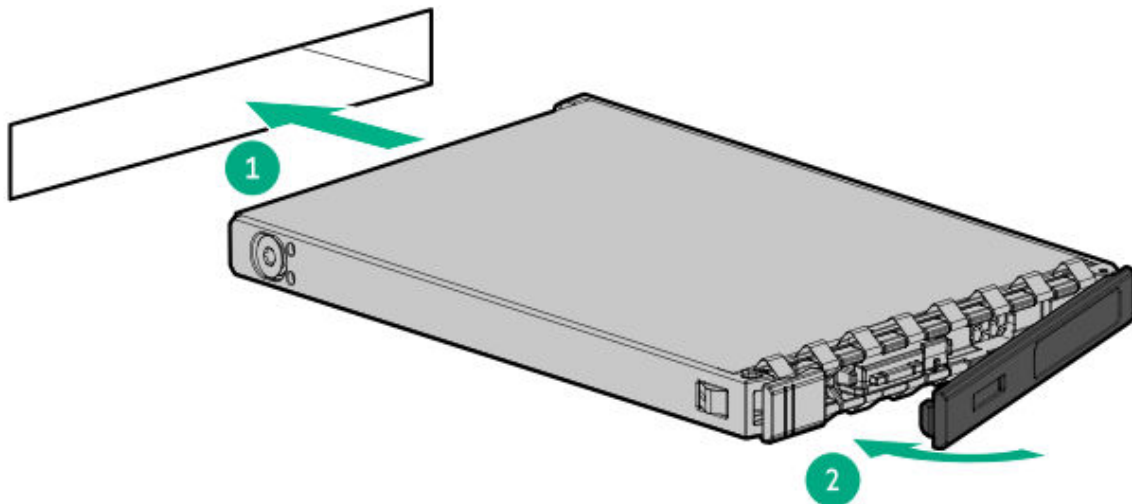

NOTE

To make sure that the drive has installed successfully, make sure that the latch is engaged with the drive cage.

6. Determine the status of the drive from the drive LED definition.
7. Install the front bezel.
8. To configure drive arrays, see the relevant storage controller guide.

Results

The installation procedure is complete.

Installing the 8 SFF drive backplane

Prerequisites

Before you perform this procedure, make sure that you have a T-15 Torx screwdriver available.

Procedure

1. Power down the server.
2. Remove all power:
 - a. Disconnect each power cord from the power source.
 - b. Disconnect each power cord from the server.
3. Disconnect all peripheral cables from the server.
4. Remove the server from the rack.
5. Place the server on a flat, level work surface.
6. Remove the access panel.
7. Remove the middle cover.
8. Remove the fans.
9. Remove the fan wall.
10. Remove the energy pack retention latch:
 - a. Pull up and hold the latch.
 - b. Push the latch to detach from the chassis.

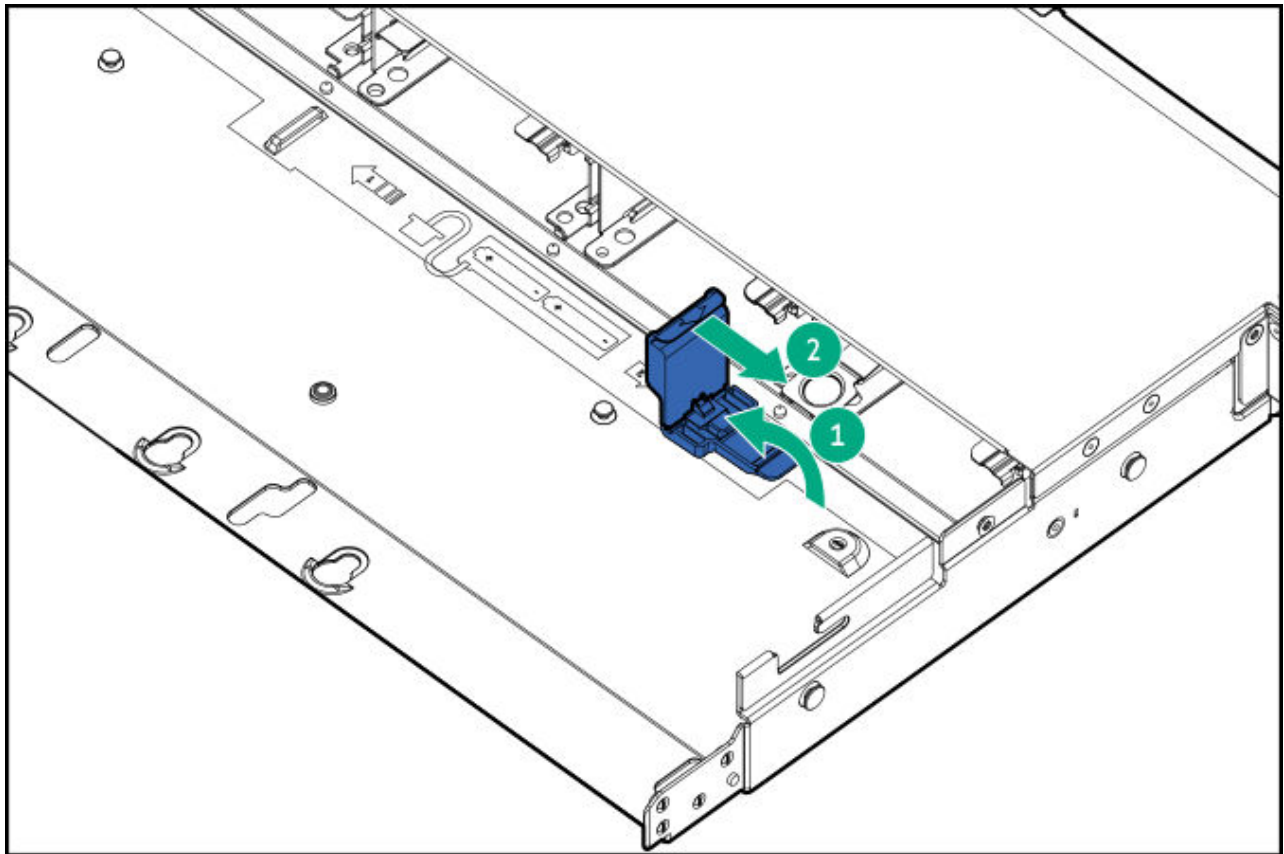

- .1. Disconnect all cables from the drive backplane.
- .2. Remove the 8 SFF drive backplane:
 - a. Lift the release latch.
 - b. Detach the backplane from the drive cage.

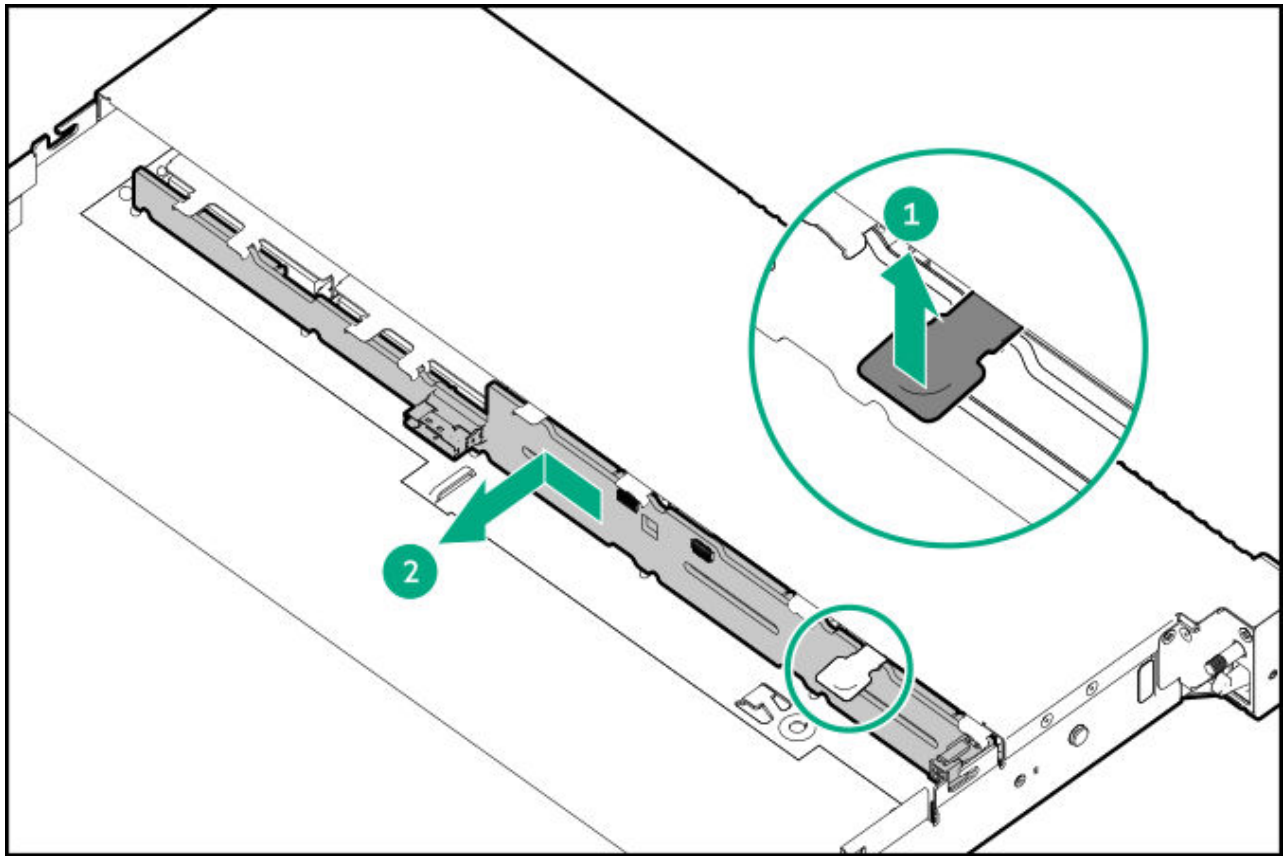

.3. Install the 8 SFF drive backplane.

Make sure the backplane is firmly seated in the drive cage and locked by the release latch.

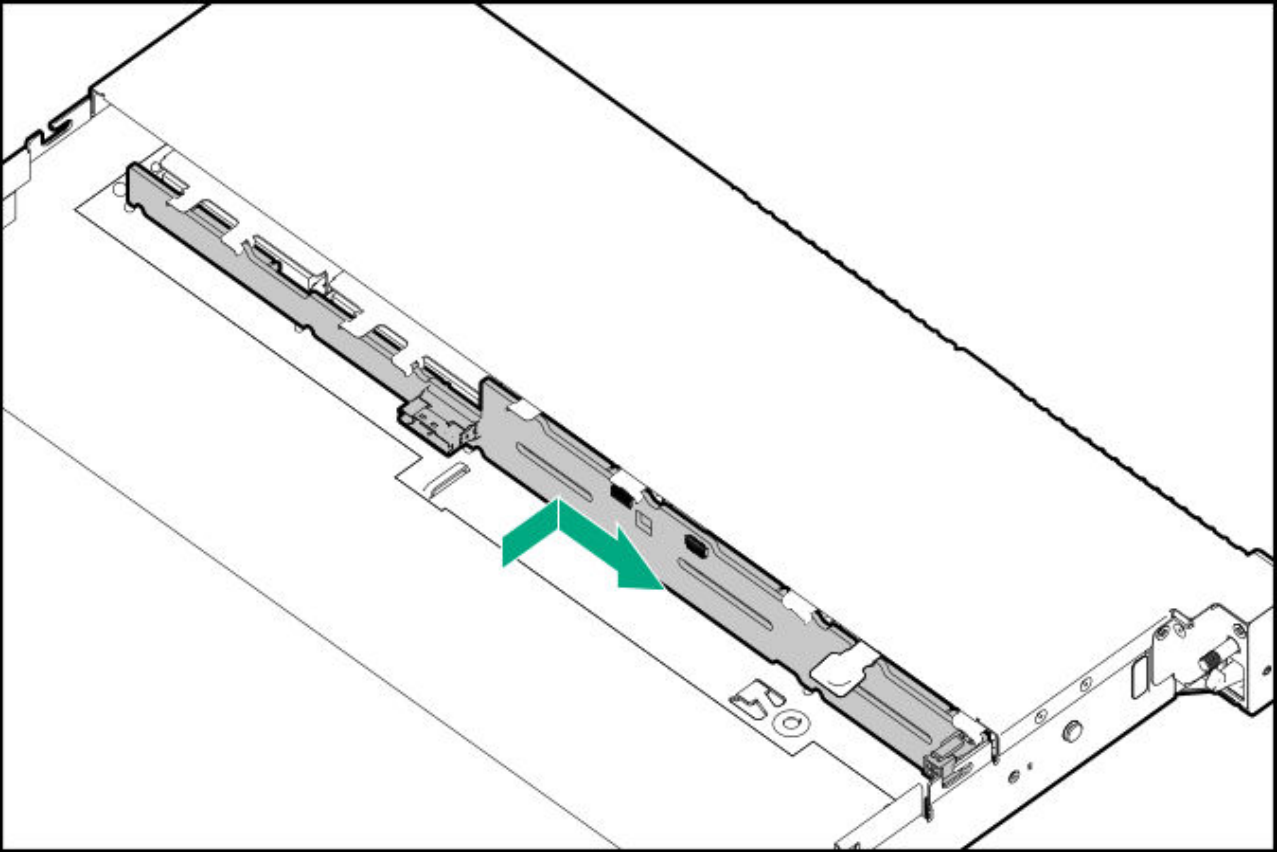

4. Connect the following cables to 8 SFF drive backplane:

- [Drive power cable](#)
- [Storage controller cable](#)

5. Install the energy pack retention latch:

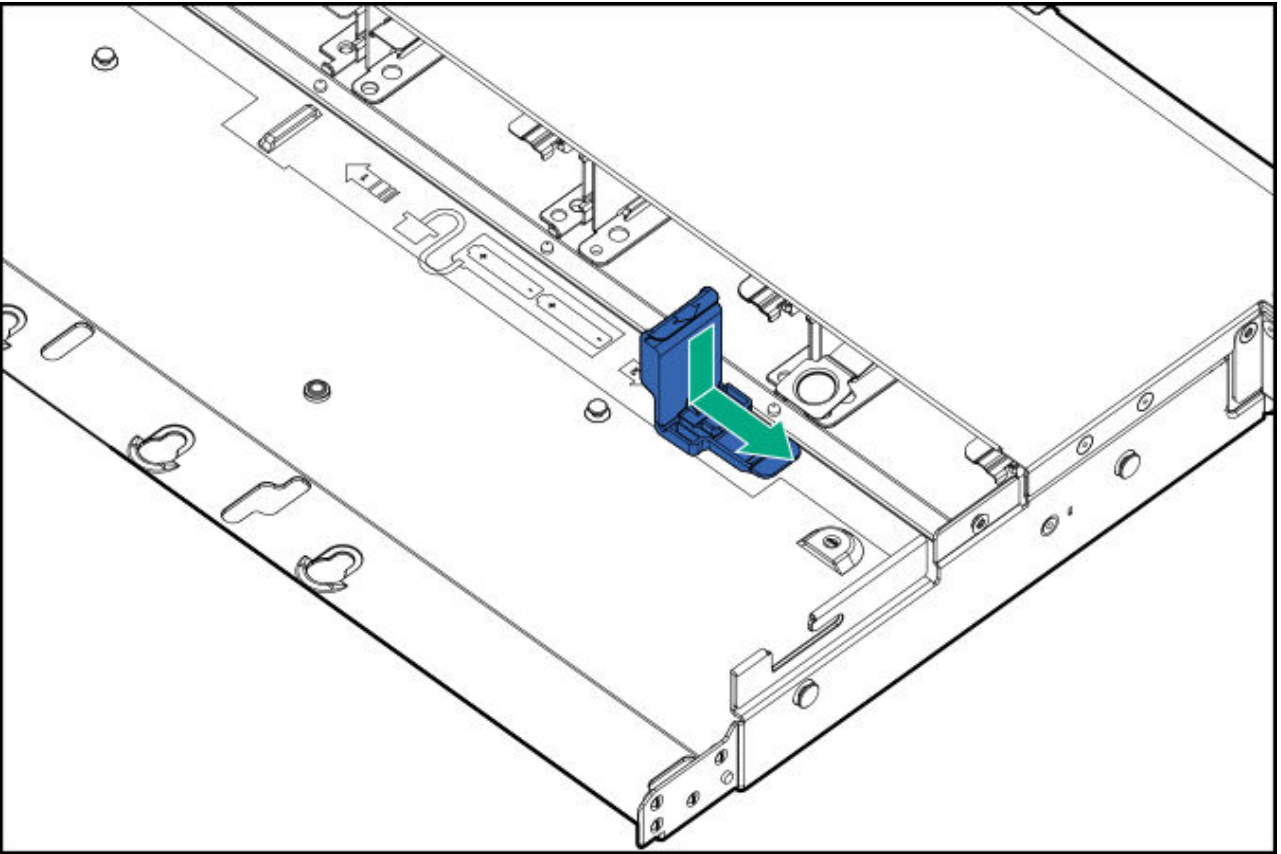

- .6. Install the fan wall.
- .7. Install the fans.
- .8. Install the middle cover.
- .9. Install the access panel.
- !0. Install the server into the rack.
- !1. Connect all peripheral cables to the server.
- !2. Connect the power cords:
 - a. Connect each power cord to the server.
 - b. Connect each power cord to the power source.
- !3. If installed, close the cable management arm.

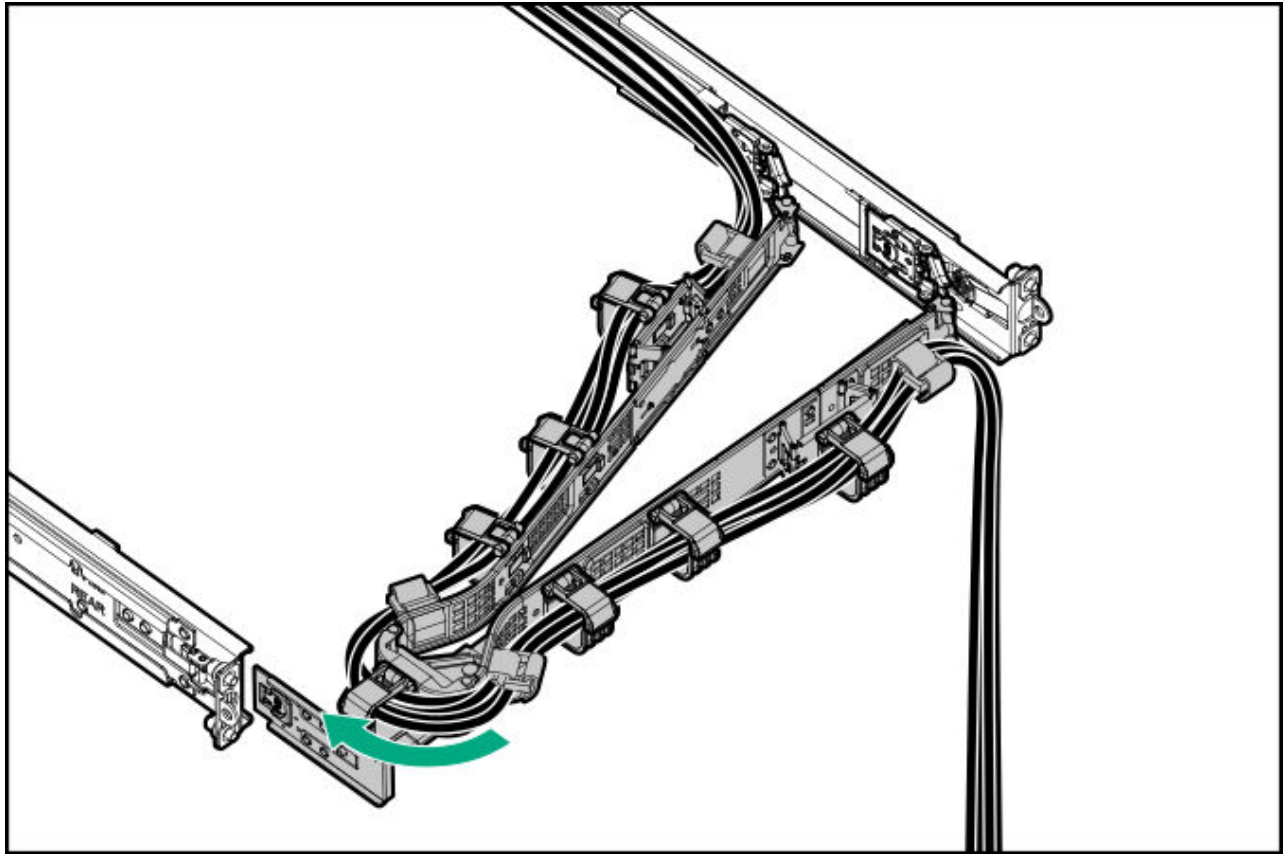

14. Power up the server.

Results

The installation procedure is complete.

Drive cage options

The server supports the following drive cage options:

- 2 SFF side-by-side drive cage
- 4 SFF drive cage
- E3.S drive cage

To maintain proper system cooling, install the correct fan and heatsink types required for specific drive configurations. For more information, see the product QuickSpecs on the HPE ProLiant DL320 Gen11 Server website:

<https://www.hpe.com/info/quickspecs>

Subtopics

[Installing the 2 SFF drive cage](#)

[Installing the 4 SFF drive cage](#)

[Installing the E3.S drive cage](#)

Installing the 2 SFF drive cage

Prerequisites

Before you perform this procedure, make sure that you have the following items available:

- T-10 Torx screwdriver
- T-15 Torx screwdriver

Procedure

1. If installed, remove the front bezel.
2. Power down the server.
3. If installed, open the cable management arm.
4. Remove all power:
 - a. Disconnect each power cord from the power source.
 - b. Disconnect each power cord from the server.
5. Disconnect all peripheral cables from the server.
6. Remove the server from the rack.
7. Place the server on a flat, level work surface.
8. Remove the access panel.
9. Remove the middle cover.
- .0. Remove the fans.
- .1. Remove the fan wall.
- .2. Remove the universal media bay blank.

Retain the screws and blank. These screws will be used to secure the new 2 SFF side-by-side drive cage assembly.

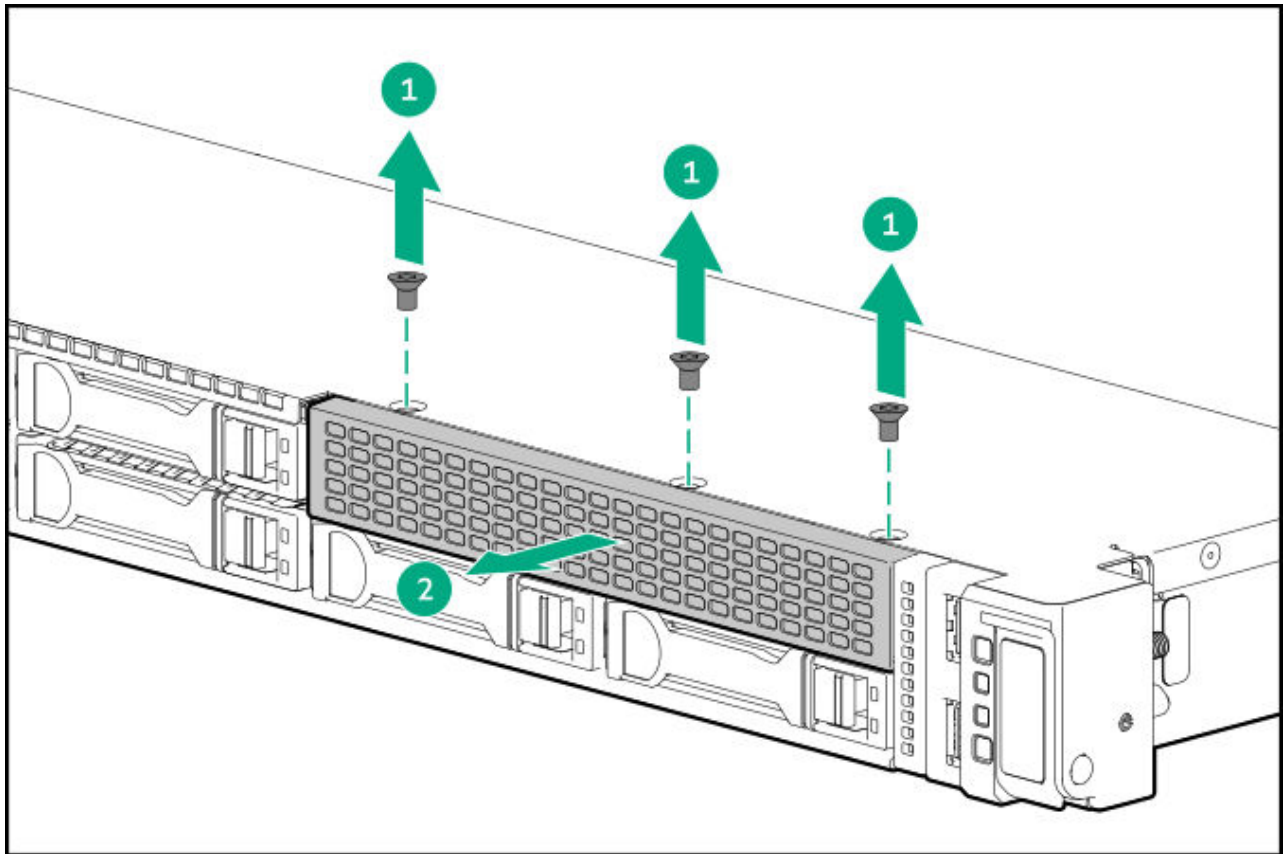

.3. Install the 2 SFF NVMe drive backplane onto the 2 SFF drive cage.

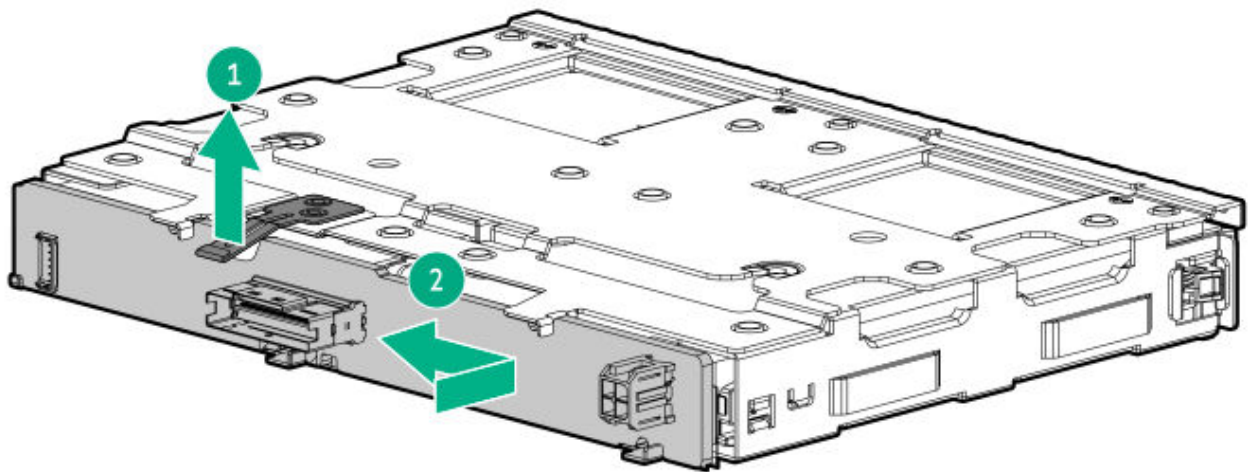

.4. Install the 2 SFF side-by-side drive cage assembly.

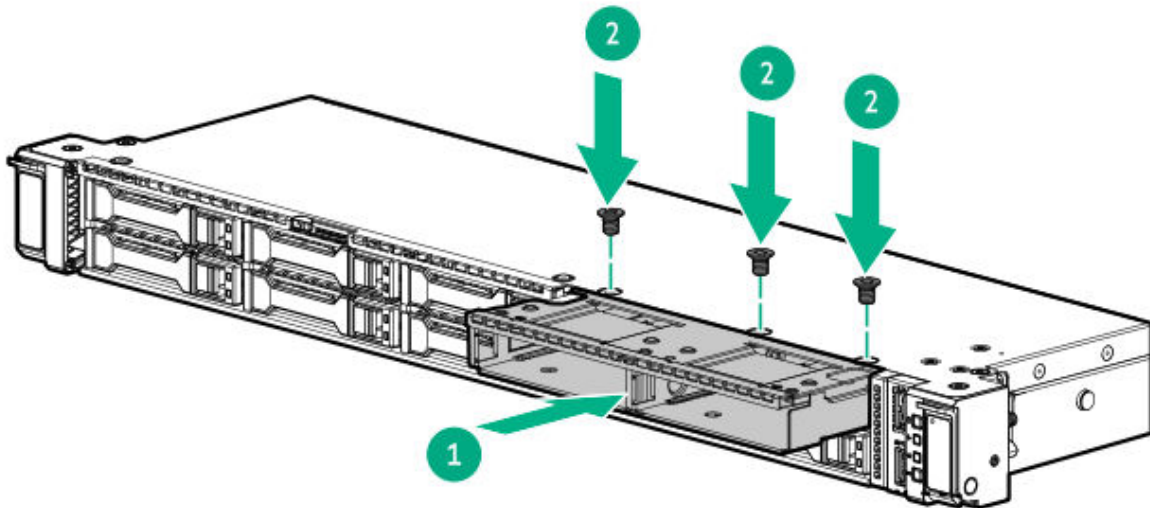

- .5. If you intend to connect the 2 SFF drive backplane to a storage controller option, install it now:
 - [Type-p storage controller](#)
- .6. Connect the following cables to the 2 SFF drive backplane:
 - [Drive power cable](#)
 - [Storage controller cable](#)
- .7. [Install the drives.](#)
- .8. [Install the fan wall.](#)
- .9. [Install the fans.](#)
- .10. [Install the middle cover.](#)
- .11. [Install the access panel.](#)
- .12. [Install the server into the rack.](#)
- .13. Connect all peripheral cables to the server.
- .14. Connect the power cords:
 - a. Connect each power cord to the server.
 - b. Connect each power cord to the power source.
- .15. If installed, close the cable management arm.

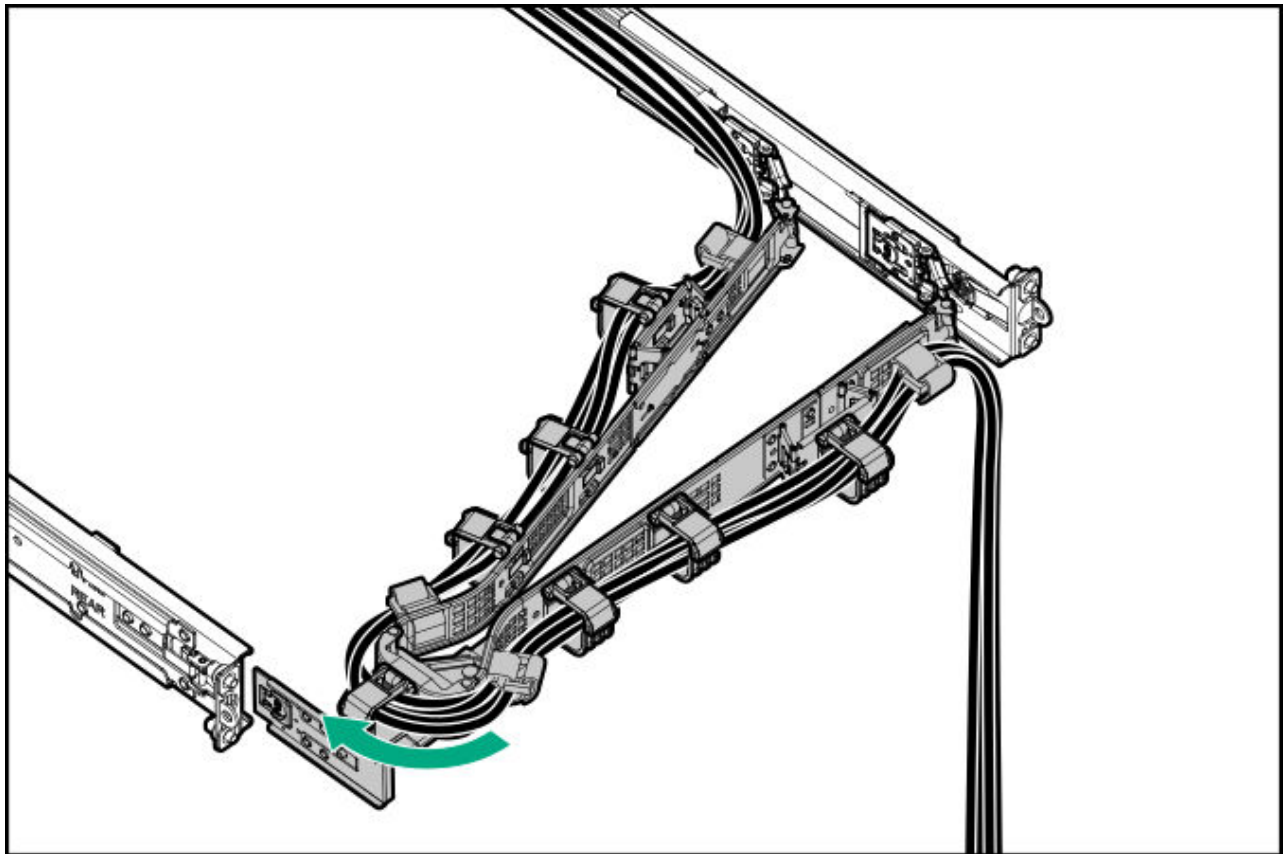

!6. Power up the server.

!7. If removed, install the front bezel.

Results

The installation procedure is complete.

Installing the 4 SFF drive cage

Prerequisites

Before you perform this procedure, make sure that you have the following items available:

- T-10 Torx screwdriver
- The components included with the hardware option kit

Procedure

1. If installed, remove the front bezel.

2. Power down the server.
3. If installed, open the cable management arm.
4. Remove all power:
 - a. Disconnect each power cord from the power source.
 - b. Disconnect each power cord from the server.
5. Disconnect all peripheral cables from the server.
6. Remove the server from the rack.
7. Place the server on a flat, level work surface.
8. Remove the access panel.
9. Remove the middle cover.
10. Install the 2 SFF drive backplanes onto the drive cage.

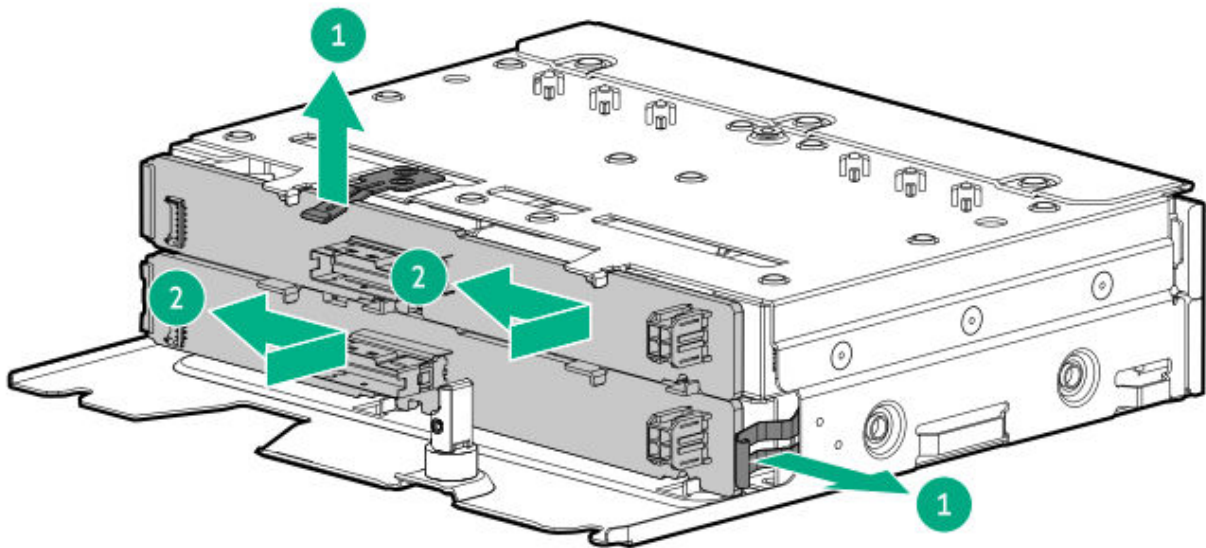

1. Connect the drive cables to the drive backplanes:
 - Drive power cable
 - Storage controller cables
2. Install the 4 SFF drive cage.

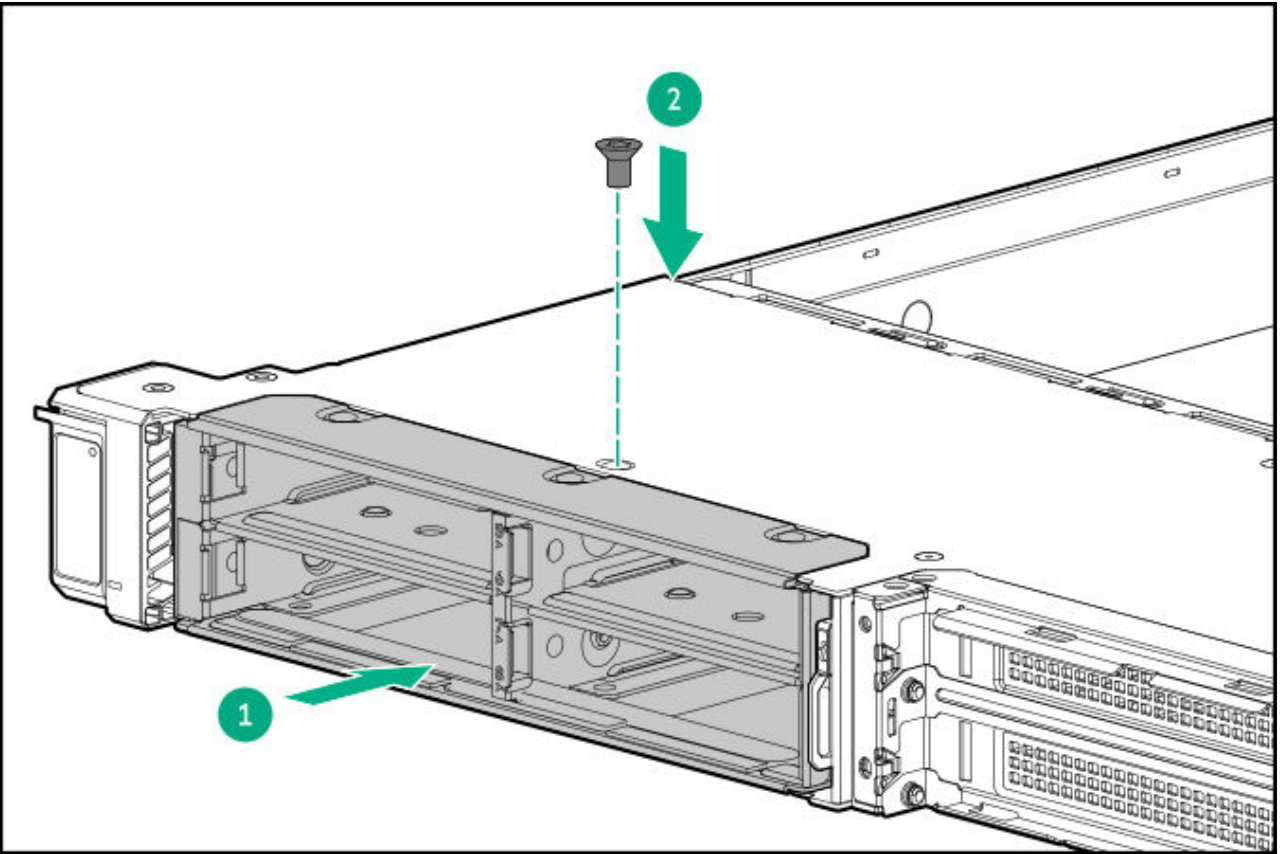

.3. Lock the drive cage.

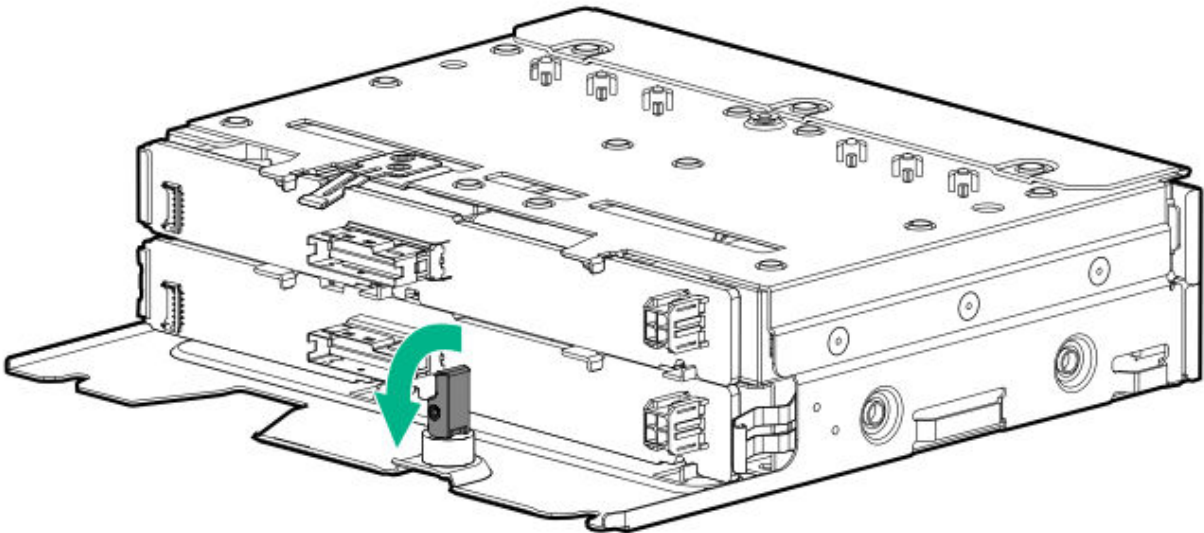

.4. Install the drives.

.5. Install the middle cover.

.6. Install the access panel.

- .7. Install the server into the rack.
- .8. Connect all peripheral cables to the server.
- .9. Connect the power cords:
 - a. Connect each power cord to the server.
 - b. Connect each power cord to the power source.
- !0. If installed, close the cable management arm.

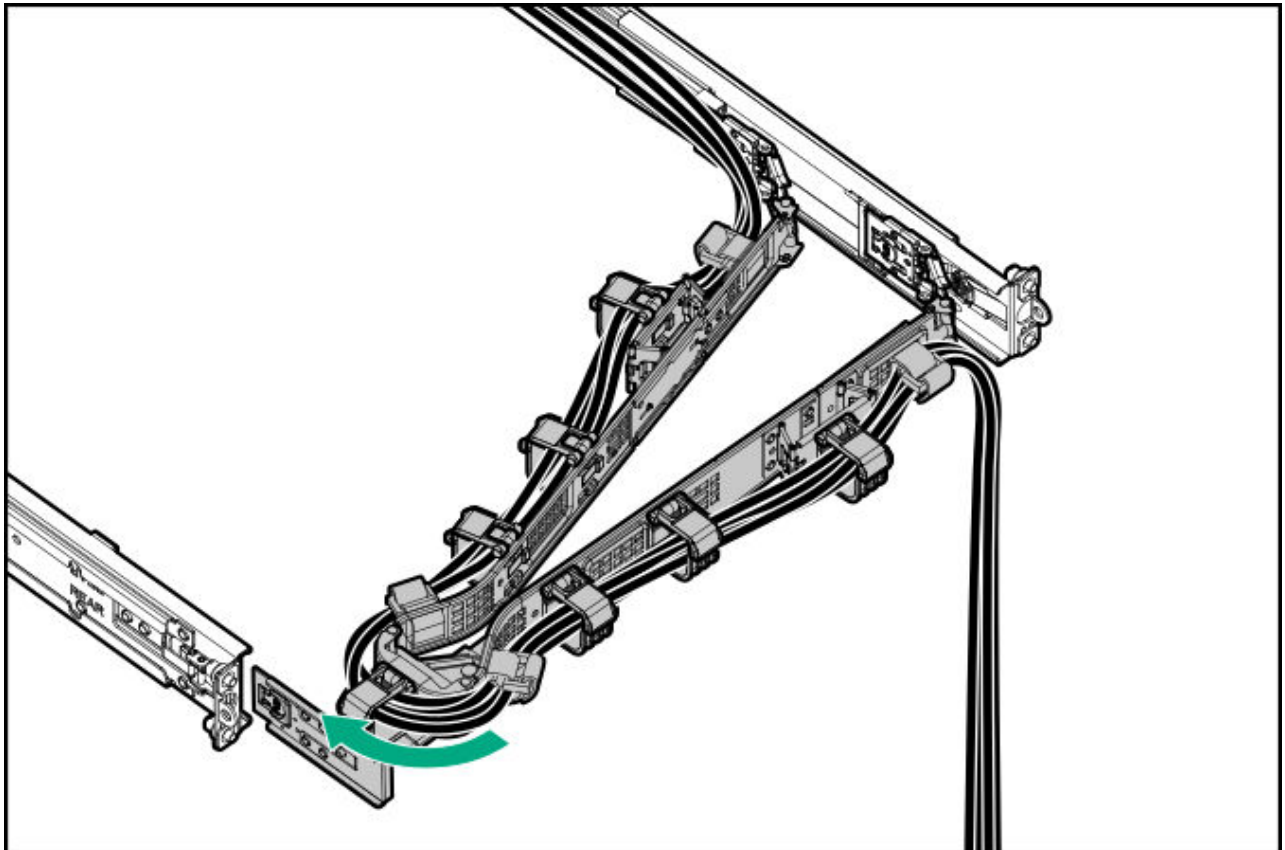

- !1. Power up the server.
- !2. If removed, install the front bezel.

Results

The installation procedure is complete.

Installing the E3.S drive cage

Prerequisites

Before you perform this procedure, make sure that you have the following items available:

- T-10 Torx screwdriver
- T-15 Torx screwdriver
- The components included with the hardware option kit

Procedure

1. If installed, remove the front bezel.
2. Power down the server.
3. If installed, open the cable management arm.
4. Remove all power:
 - a. Disconnect each power cord from the power source.
 - b. Disconnect each power cord from the server.
5. Disconnect all peripheral cables from the server.
6. Remove the server from the rack.
7. Place the server on a flat, level work surface.
8. Remove the access panel.
9. Remove the middle cover.
- .0. Install the E3.S drive backplane onto the drive cage.

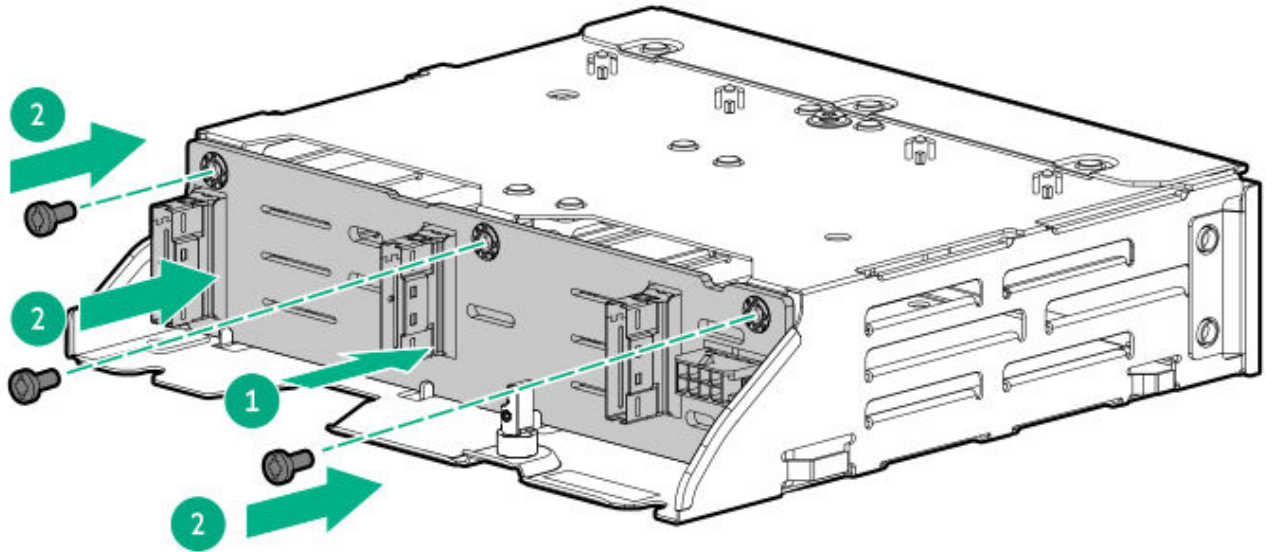

.1. Connect the drive cables to the drive backplanes:

- [Drive power cable](#)
- [Storage controller cables](#)

.2. Install the E3.S drive cage.

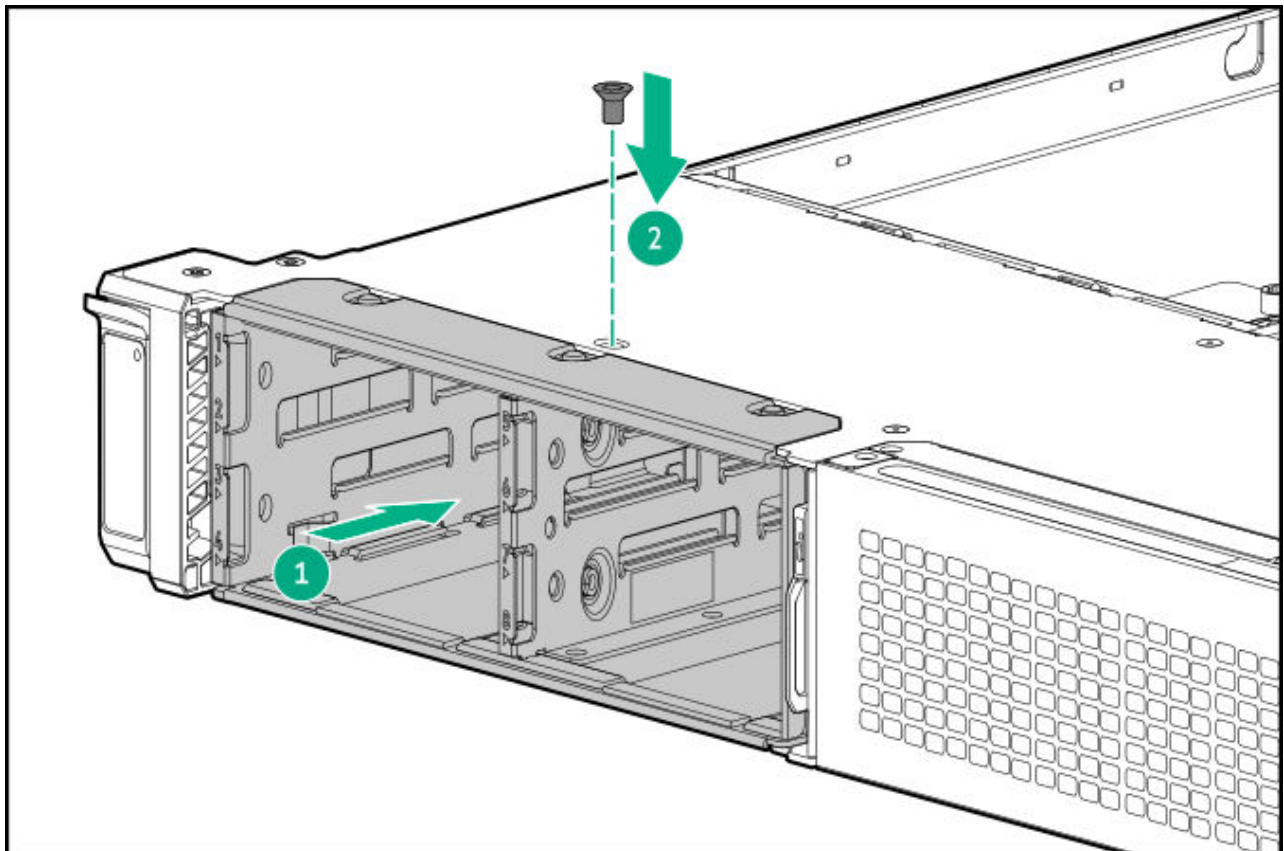

.3. Lock the drive cage.

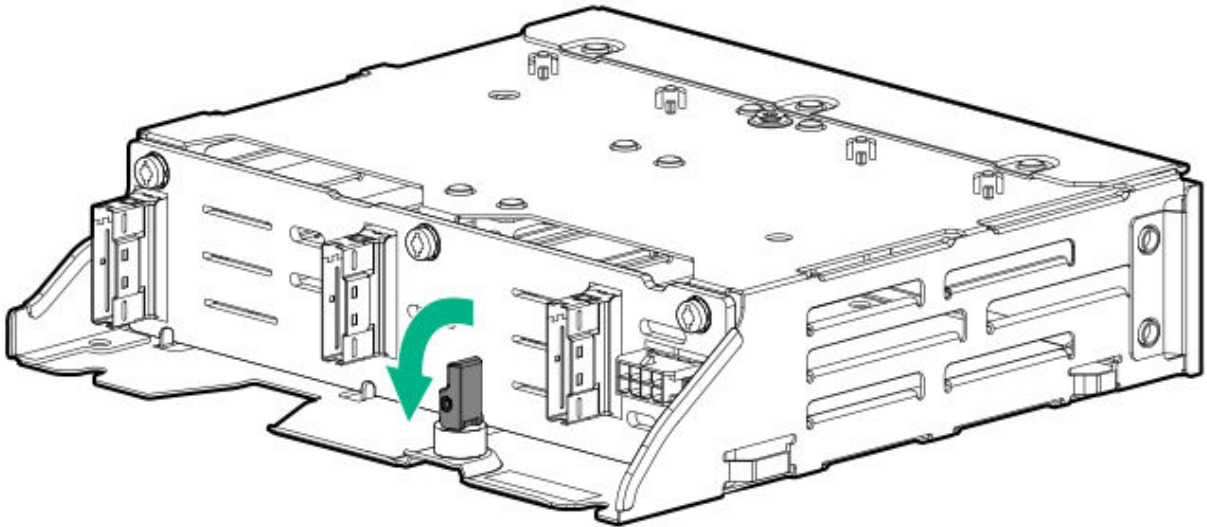

.4. Install the drives.

.5. Install the middle cover.

.6. Install the access panel.

.7. Install the server into the rack.

.8. Connect all peripheral cables to the server.

.9. Connect the power cords:

a. Connect each power cord to the server.

b. Connect each power cord to the power source.

.10. If installed, close the cable management arm.

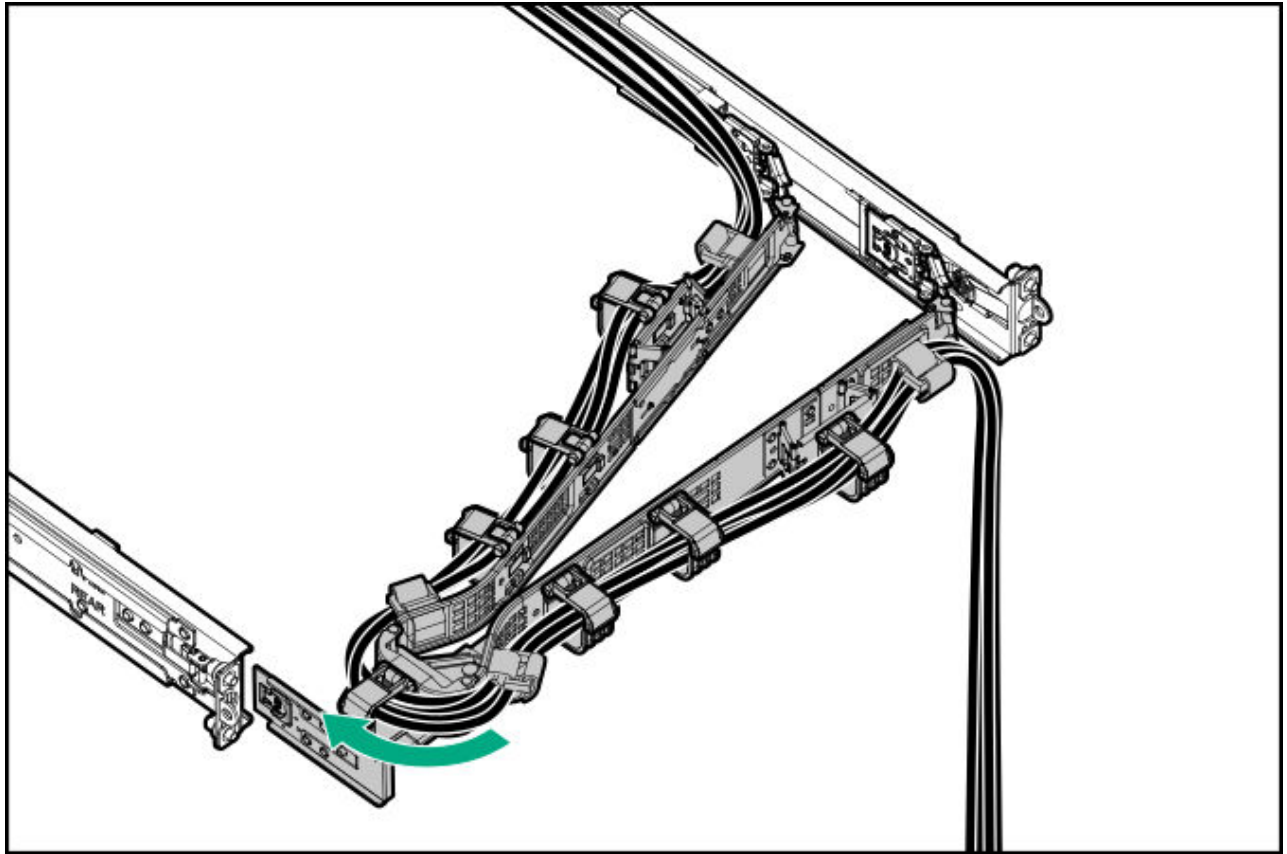

1. Power up the server.
2. If removed, install the front bezel.

Results

The installation procedure is complete.

Optical drive option

Subtopics

Installing an optical drive in the SFF drive chassis

Installing an optical drive in the LFF drive chassis

Installing an optical drive in the SFF drive chassis

Prerequisites

Before you perform this procedure, make sure that you have the following items available:

- T-10 Torx screwdriver
- Phillips No. 1 screwdriver

About this task



CAUTION

A discharge of static electricity from a finger or other conductor might damage system boards or other static-sensitive devices. To prevent damage, observe antistatic precautions.

Procedure

1. If installed, remove the front bezel.
2. Power down the server.
3. If installed, open the cable management arm.
4. Remove all power:
 - a. Disconnect each power cord from the power source.
 - b. Disconnect each power cord from the server.
5. Disconnect all peripheral cables from the server.
6. Remove the server from the rack.
7. Place the server on a flat, level work surface.
8. Remove the access panel.
9. Remove the middle cover.
10. Remove the universal media bay blank.

Retain the screws and blank. These screws will be used to secure the new optical drive cage.

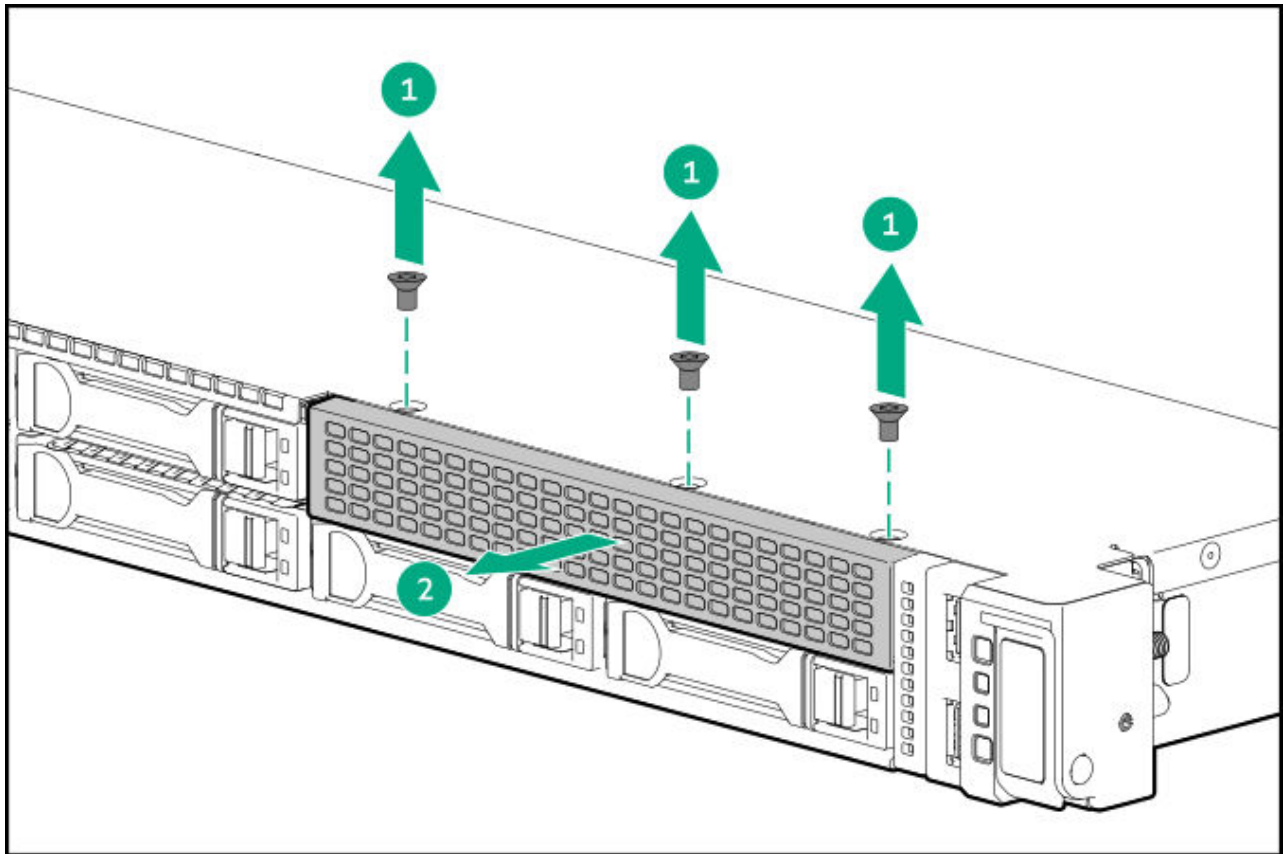

- .1. Remove the optical drive bay blank from the drive cage.

Retain the blank for future use.

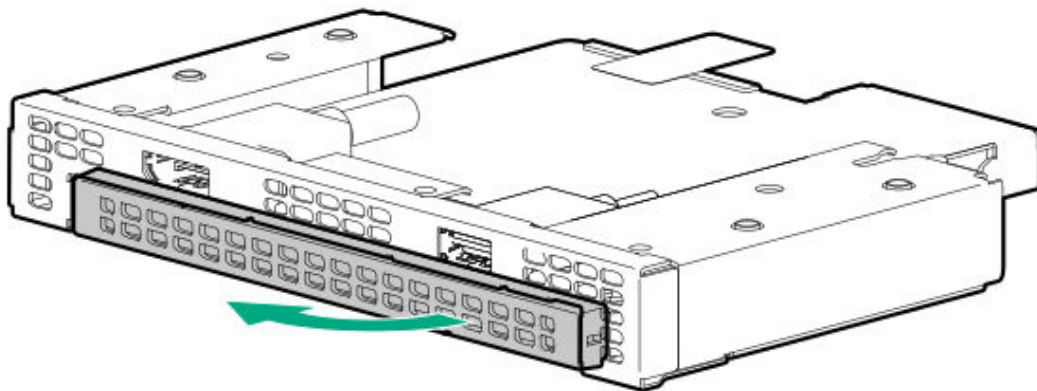

- .2. Install the optical drive bracket.

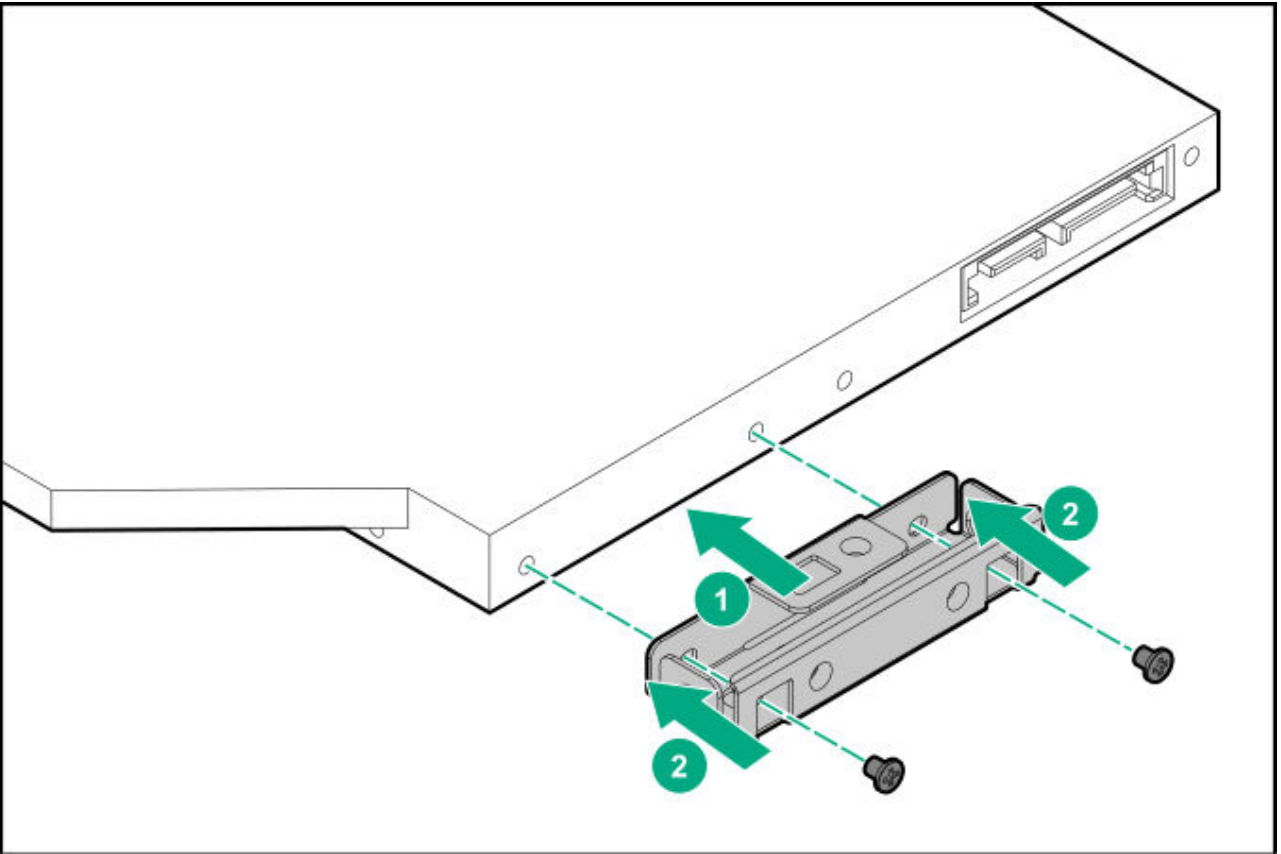

.3. Install the optical drive in the optical drive cage.

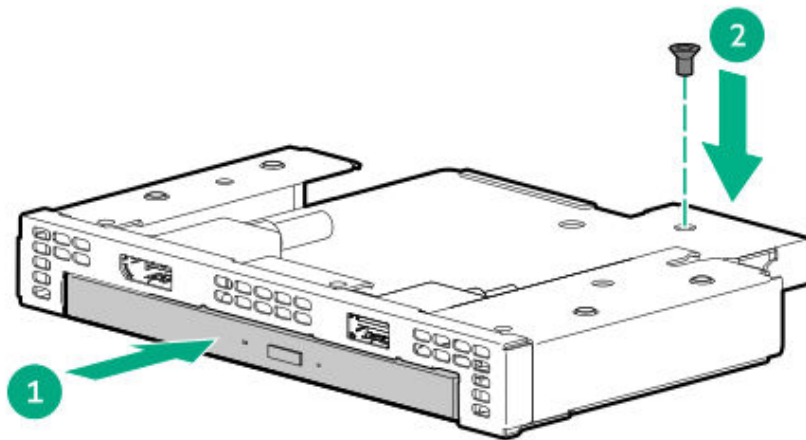

.4. Install the optical drive cage in the universal media bay.

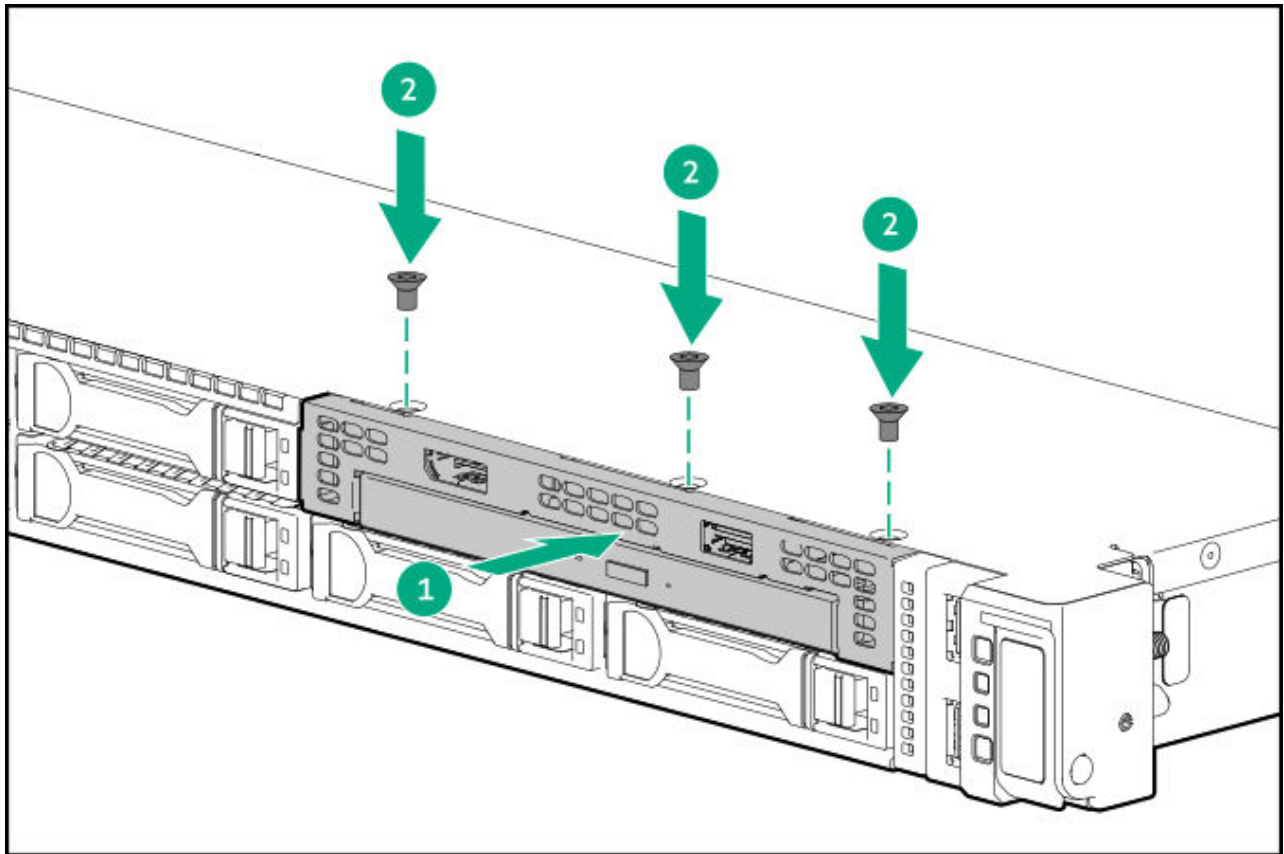

5. Cable the optical drive.
6. Install the middle cover.
7. Install the access panel.
8. Install the server into the rack.
9. Connect all peripheral cables to the server.
10. Connect the power cords:
 - a. Connect each power cord to the server.
 - b. Connect each power cord to the power source.
11. If installed, close the cable management arm.

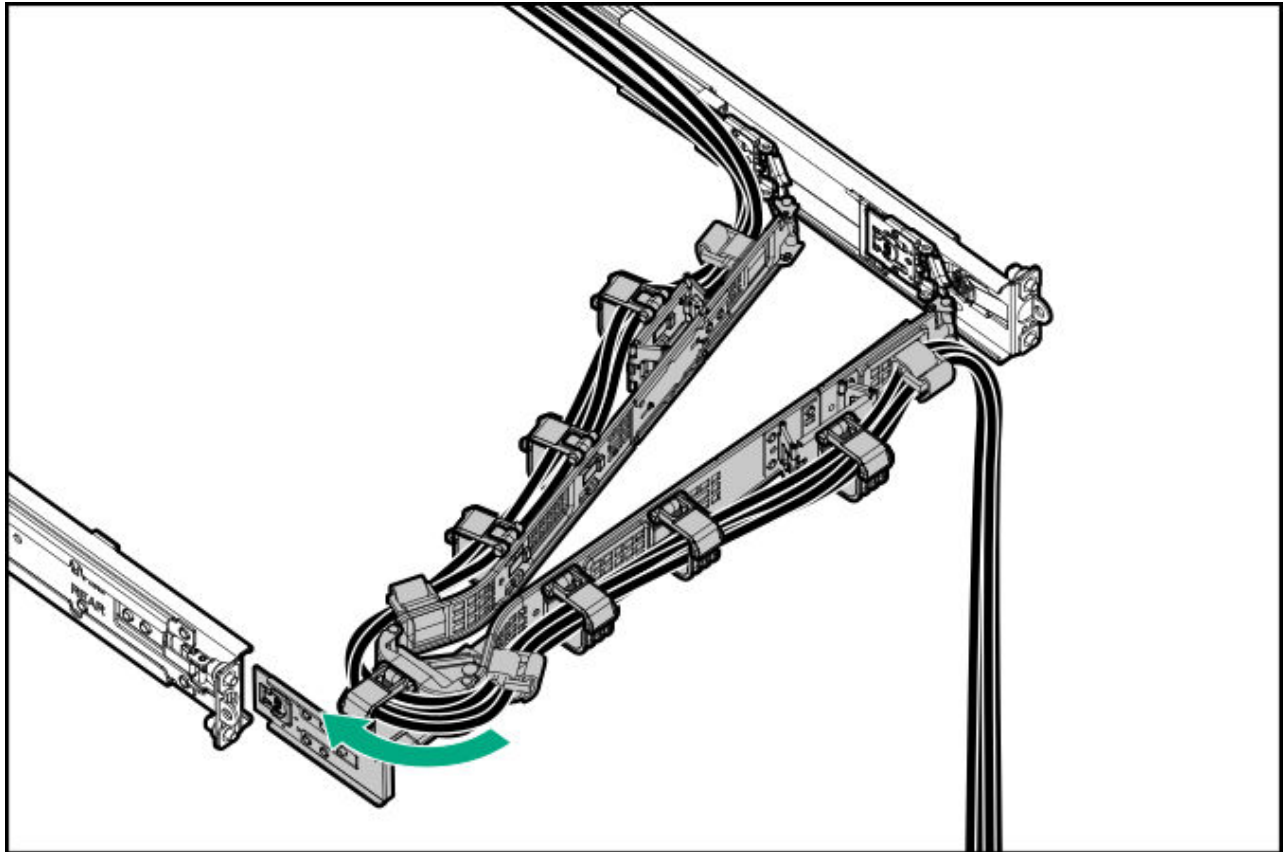

!2. Power up the server.

!3. If removed, install the front bezel.

Results

The installation procedure is complete.

Installing an optical drive in the LFF drive chassis

Prerequisites

Before you perform this procedure, make sure that you have the following items available:

- T-10 Torx screwdriver
- Phillips No. 1 screwdriver
- The components included with the hardware option kit
- LFF optical cable option kit

- An optical drive

About this task



CAUTION

A discharge of static electricity from a finger or other conductor might damage system boards or other static-sensitive devices. To prevent damage, observe antistatic precautions.

Procedure

1. If installed, remove the front bezel.
2. Power down the server.
3. If installed, open the cable management arm.
4. Remove all power:
 - a. Disconnect each power cord from the power source.
 - b. Disconnect each power cord from the server.
5. Disconnect all peripheral cables from the server.
6. Remove the server from the rack.
7. Place the server on a flat, level work surface.
8. Remove the access panel.
9. Remove the middle cover.
0. Remove the optical drive bay blank.

Retain the drive bay blank for future use.

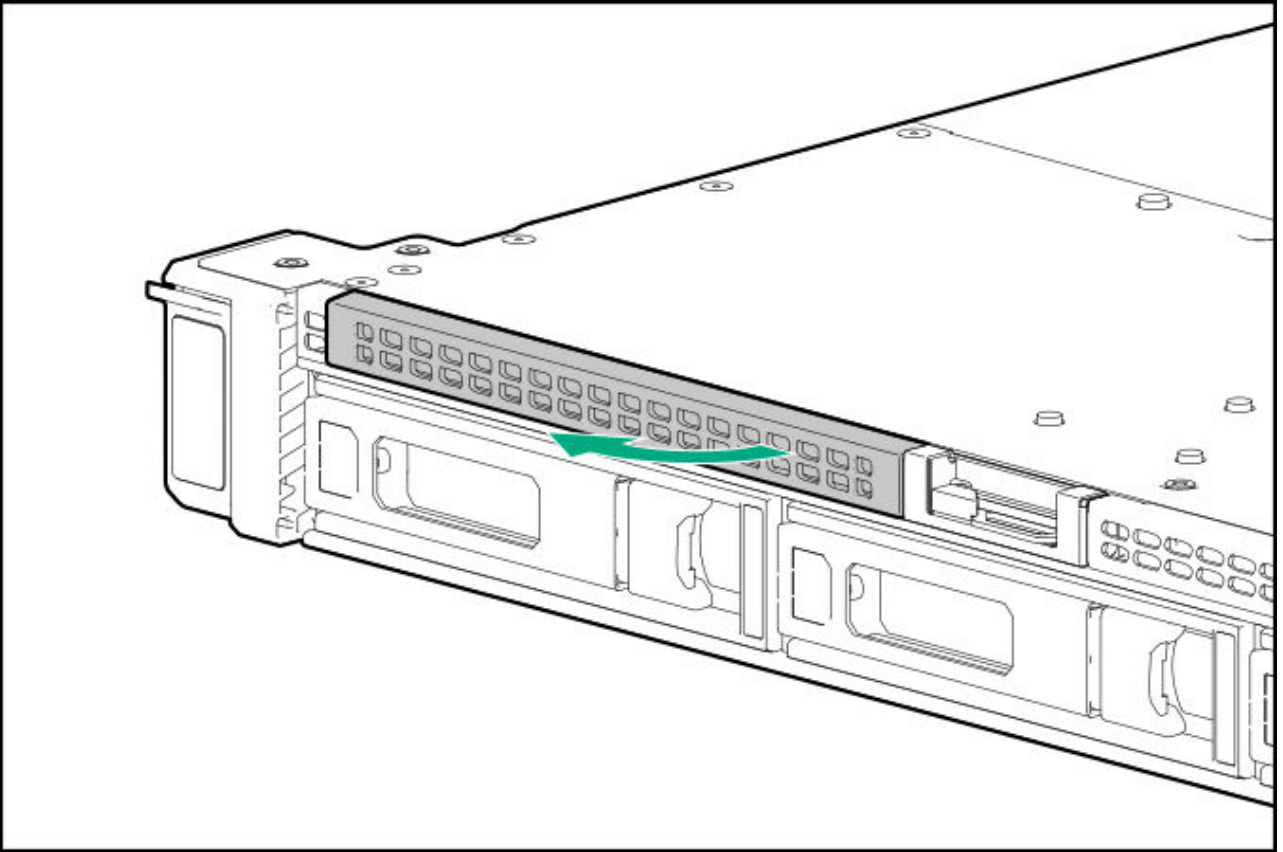

.1. Install the optical drive bracket.

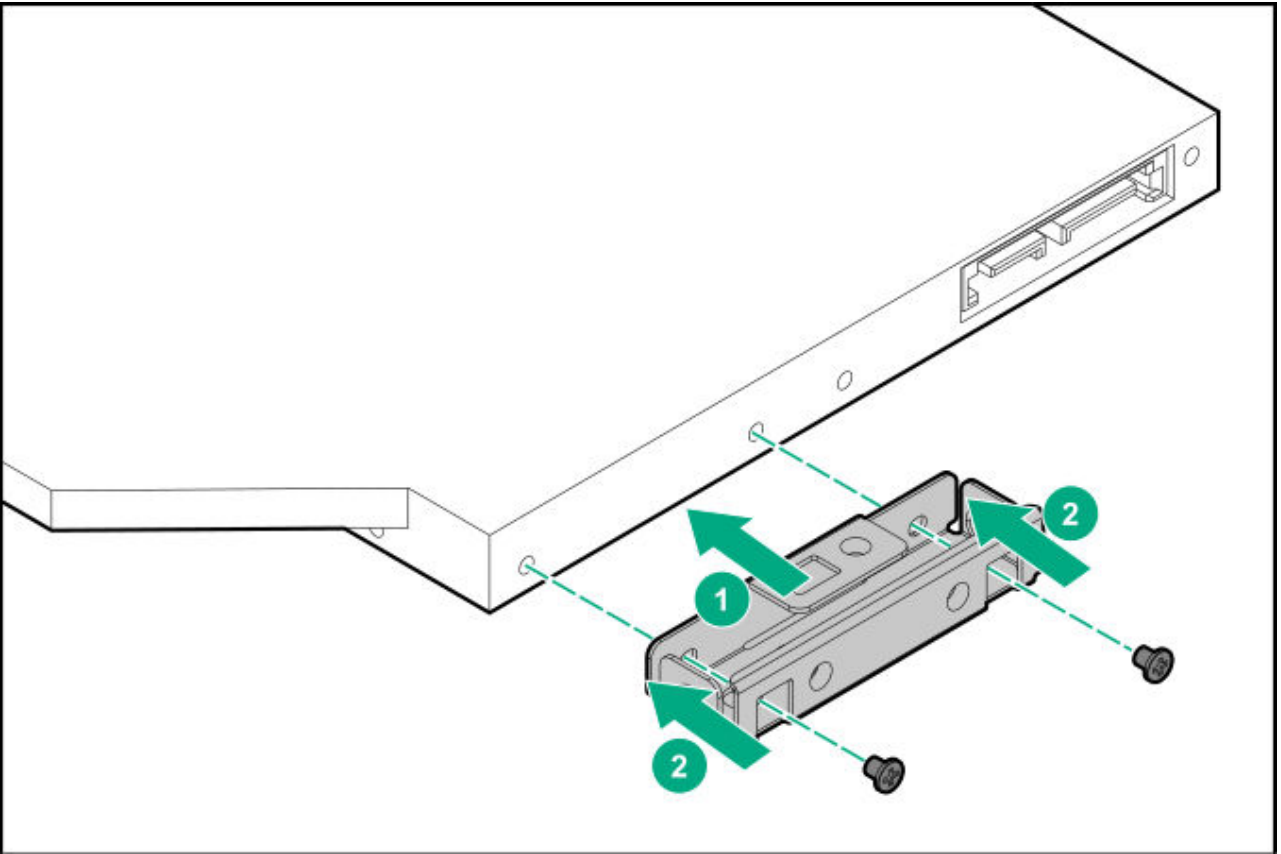

.2. Install the optical drive.

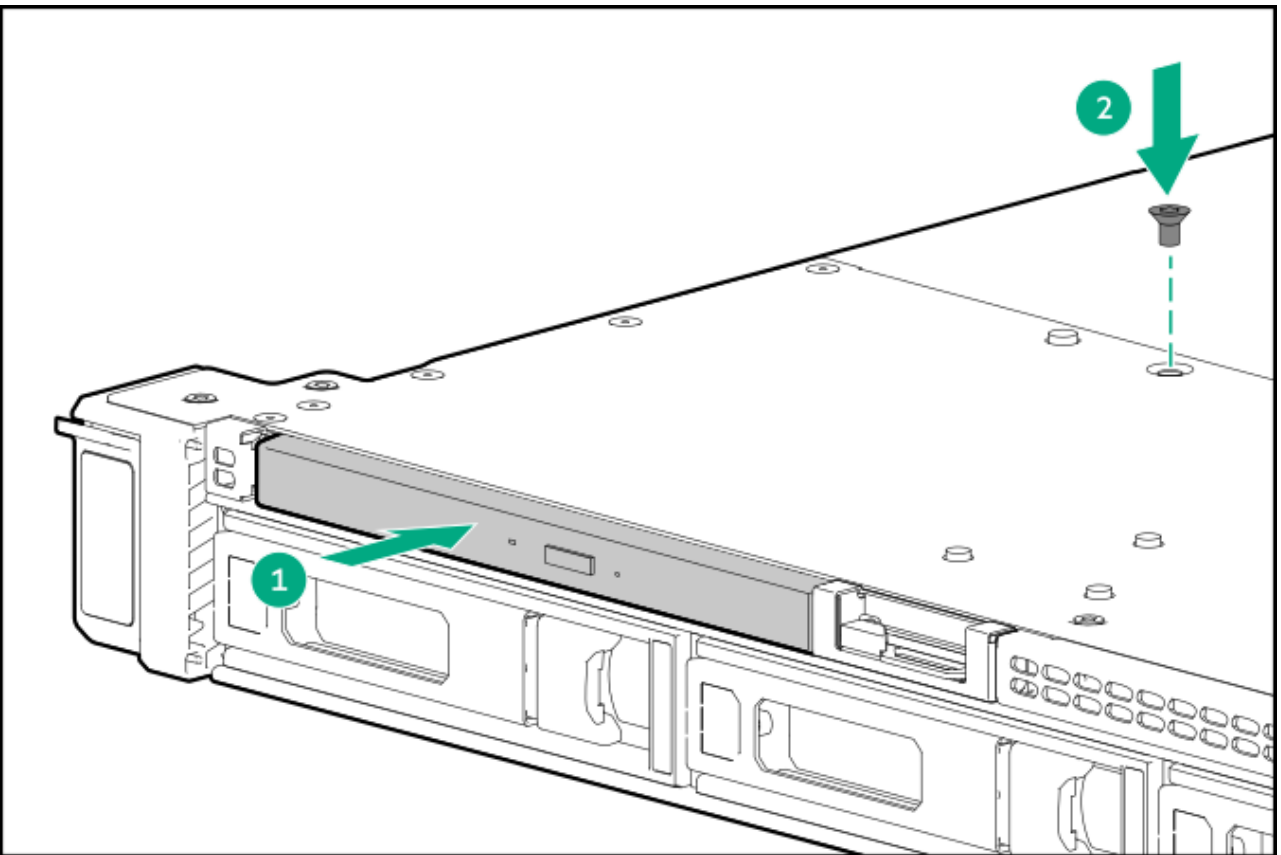

- .3. Cable the optical drive.
- .4. Install the middle cover.
- .5. Install the access panel.
- .6. Install the server into the rack.
- .7. Connect all peripheral cables to the server.
- .8. Connect the power cords:
 - a. Connect each power cord to the server.
 - b. Connect each power cord to the power source.
- .9. If installed, close the cable management arm.

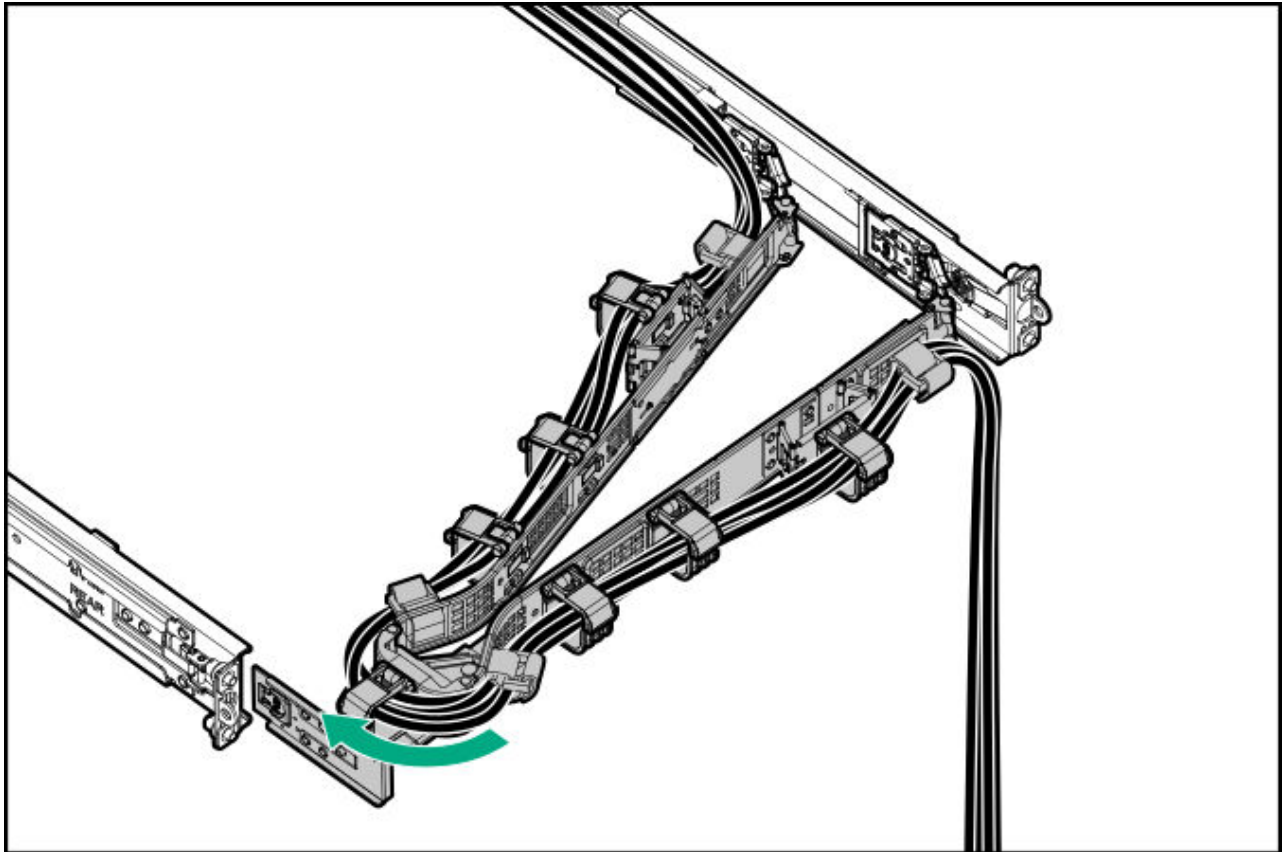

- !0. Power up the server.
- !1. If removed, install the front bezel.

Results

The installation procedure is complete.

Display port option

Subtopics

[Installing an 8 SFF display port/USB/optical blank option](#)

[Installing the 4 LFF display port/USB option](#)

Installing an 8 SFF display port/USB/optical blank option

Prerequisites

Before you perform this procedure, make sure that you have the following items available:

- T-10 Torx screwdriver
- Phillips No. 1 screwdriver

Procedure

1. If installed, remove the front bezel.
2. Power down the server.
3. If installed, open the cable management arm.
4. Remove all power:
 - a. Disconnect each power cord from the power source.
 - b. Disconnect each power cord from the server.
5. Disconnect all peripheral cables from the server.
6. Remove the server from the rack.
7. Place the server on a flat, level work surface.
8. Remove the access panel.
9. Remove the middle cover.
0. Remove the universal media bay blank.

Retain the screws and blank. These screws will be used to secure the new optical drive cage.

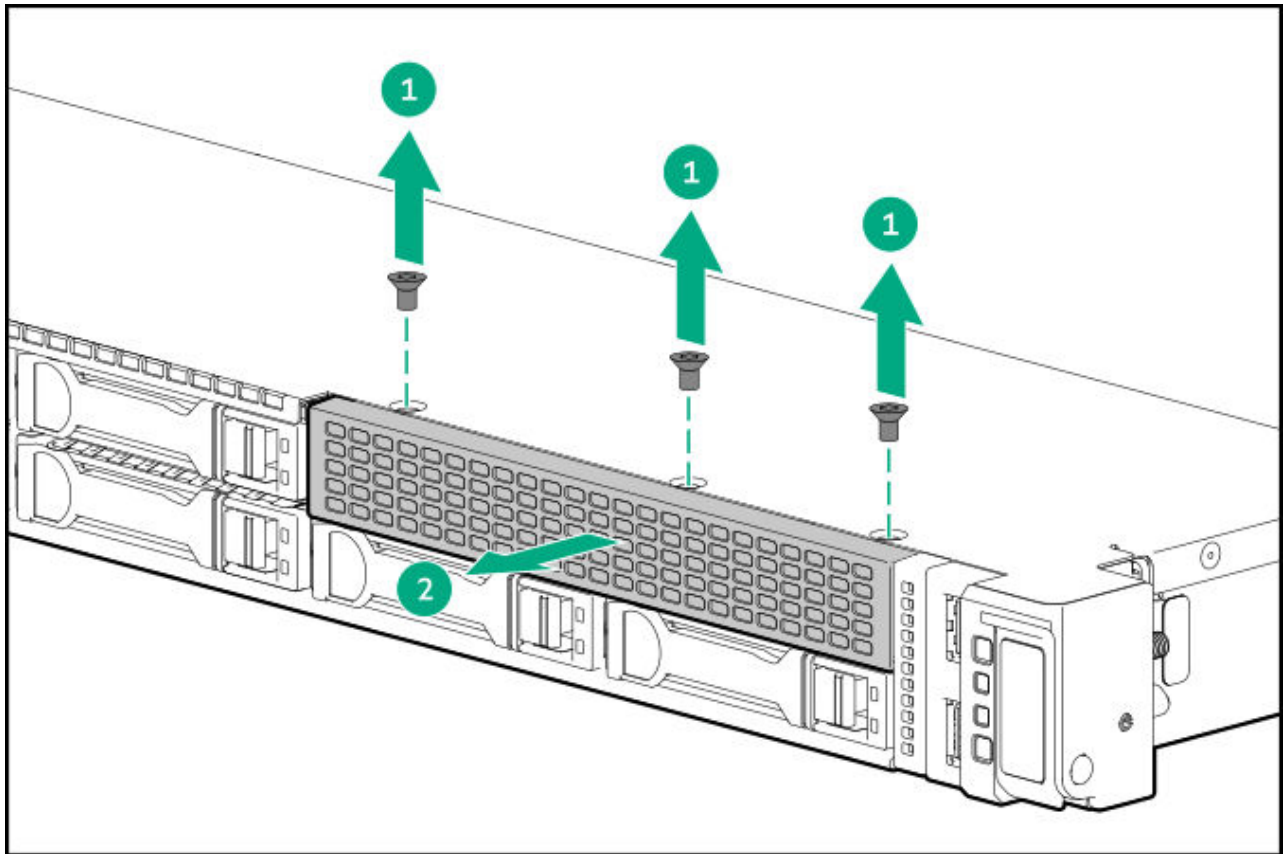

- .1. Remove the optical drive bay blank from the drive cage.

Retain the blank for future use.

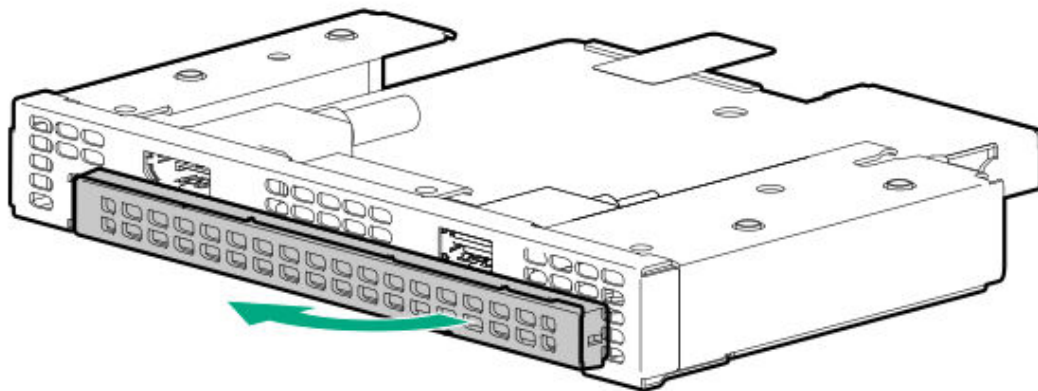

- .2. Install the optical drive bracket.

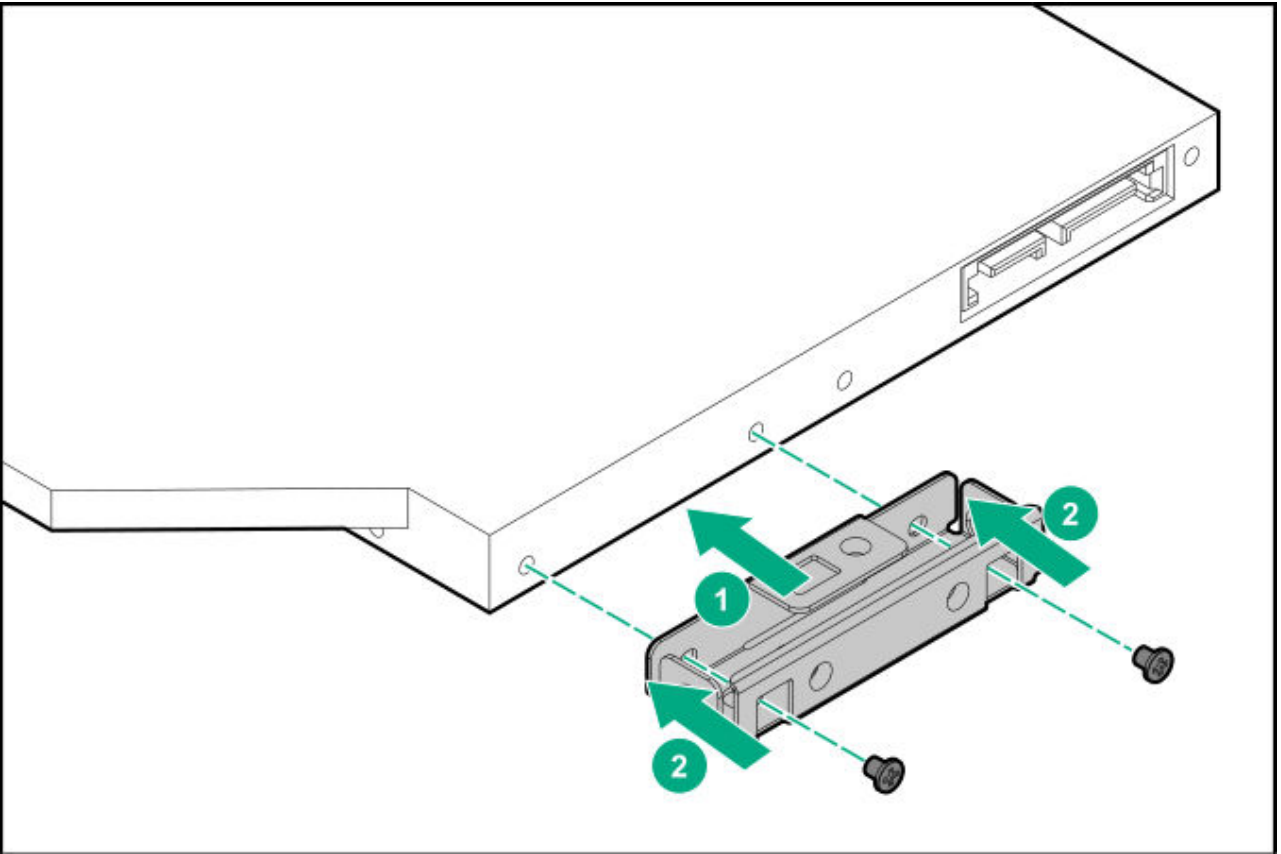

.3. Install the optical drive in the optical drive cage.

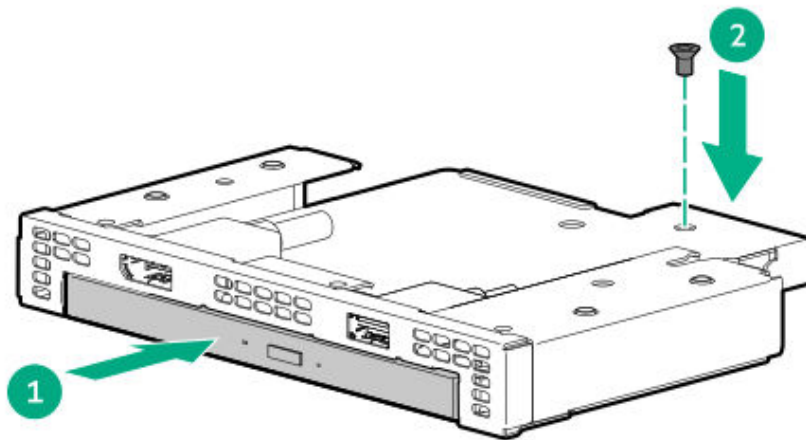

.4. Install the optical drive cage in the universal media bay.

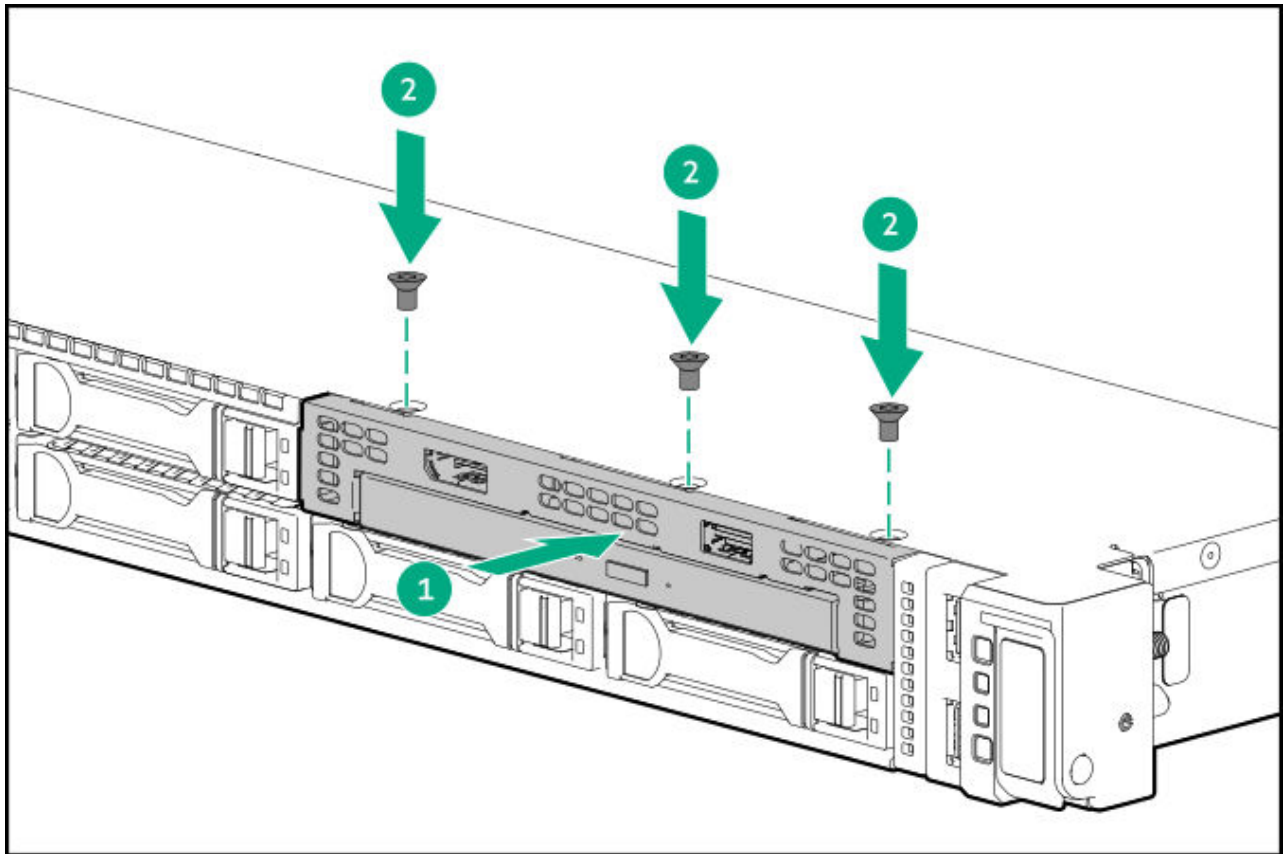

5. Cable the option.
6. Install the middle cover.
7. Install the access panel.
8. Install the server into the rack.
9. Connect all peripheral cables to the server.
10. Connect the power cords:
 - a. Connect each power cord to the server.
 - b. Connect each power cord to the power source.
11. If installed, close the cable management arm.

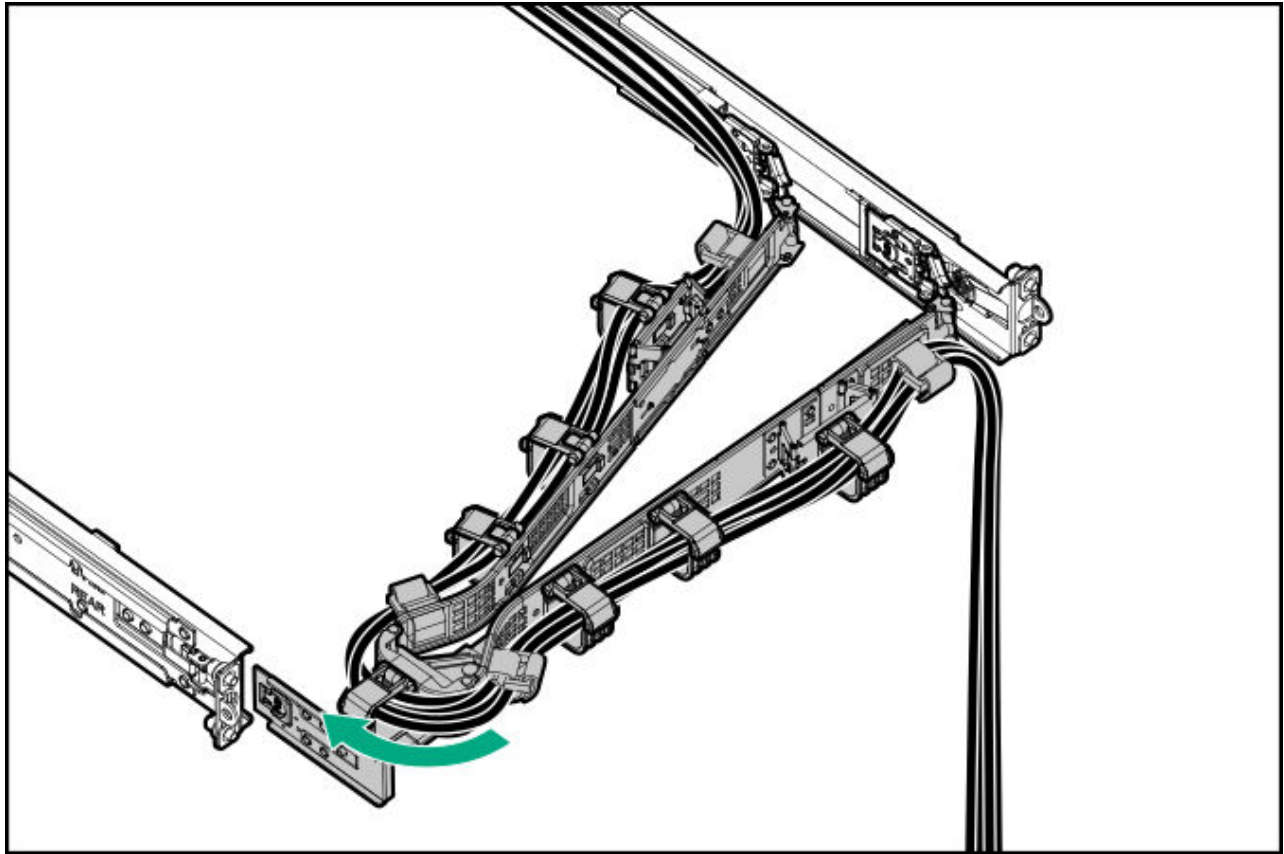

2. Power up the server.
3. If removed, install the front bezel.

Results

The installation procedure is complete.

Installing the 4 LFF display port/USB option

Prerequisites

Before you perform this procedure, make sure that you have a T-10 Torx screwdriver available.

Procedure

1. If installed, remove the front bezel.
2. Power down the server.
3. If installed, open the cable management arm.

4. Remove all power:
 - a. Disconnect each power cord from the power source.
 - b. Disconnect each power cord from the server.
5. Disconnect all peripheral cables from the server.
6. Remove the server from the rack.
7. Place the server on a flat, level work surface.
8. Remove the access panel.
9. Remove the middle cover.
10. Remove the front USB and DisplayPort blank.

Retain the screws. These screws will be used to secure the front USB and DisplayPort assembly.

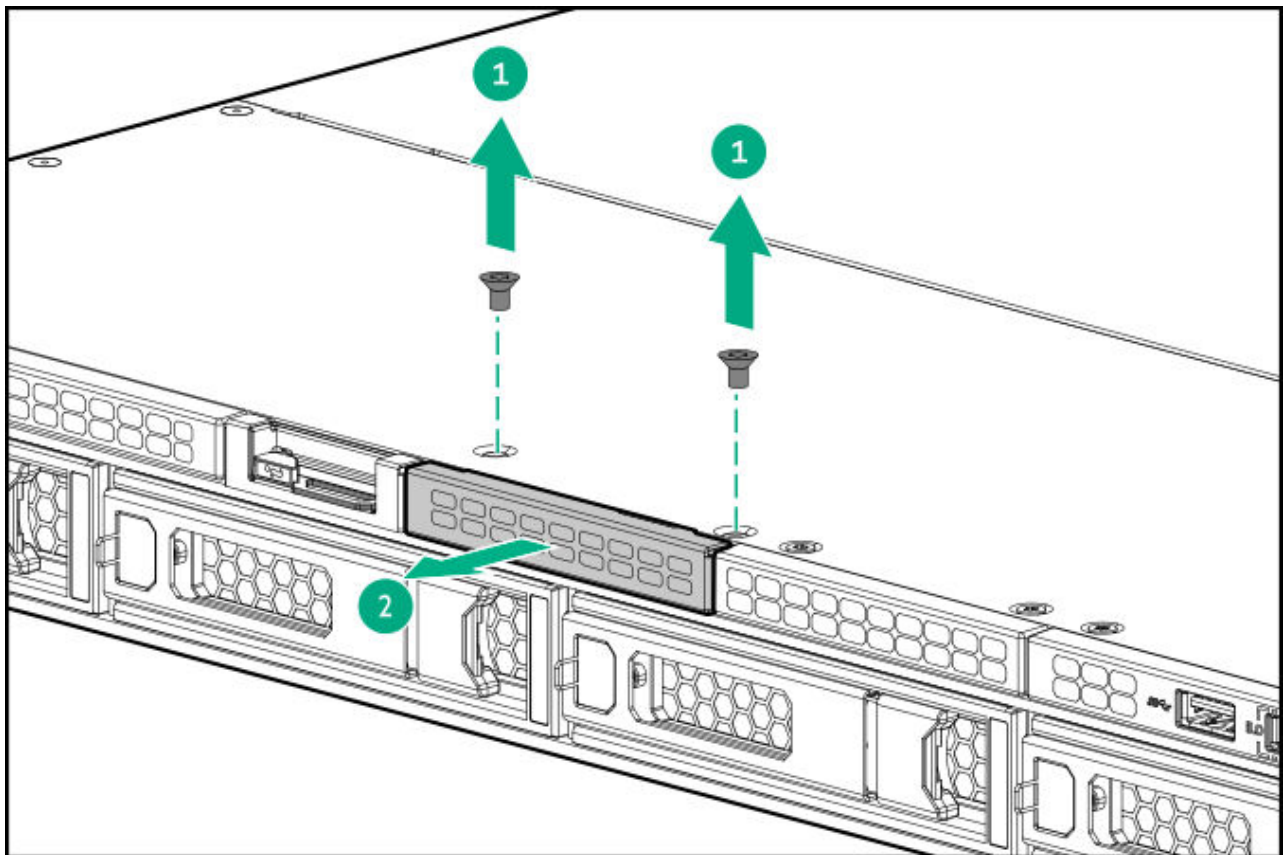

1. Install the front USB and DisplayPort assembly.

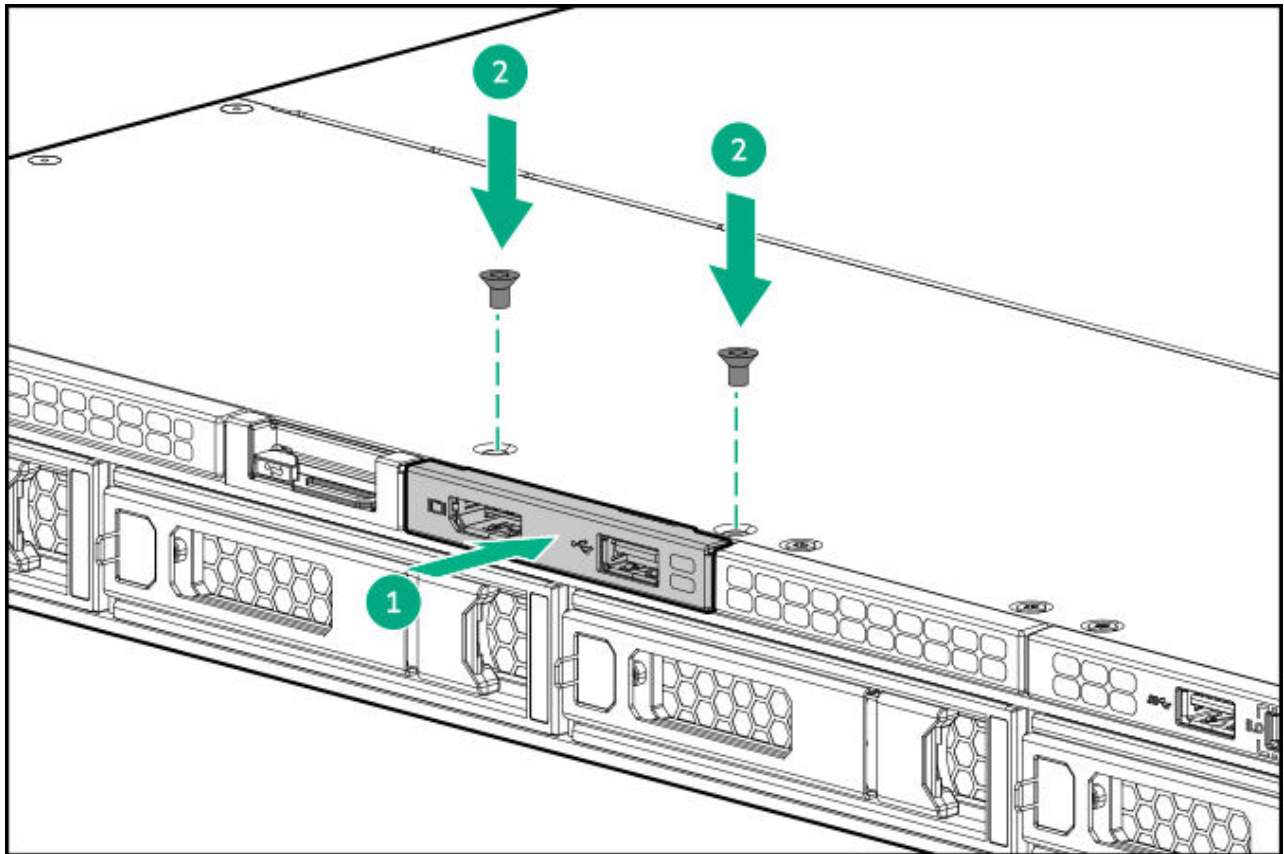

- .2. Cable the option.
- .3. Install the middle cover.
- .4. Install the access panel.
- .5. Install the server into the rack.
- .6. Connect all peripheral cables to the server.
- .7. Connect the power cords:
 - a. Connect each power cord to the server.
 - b. Connect each power cord to the power source.
- .8. If installed, close the cable management arm.

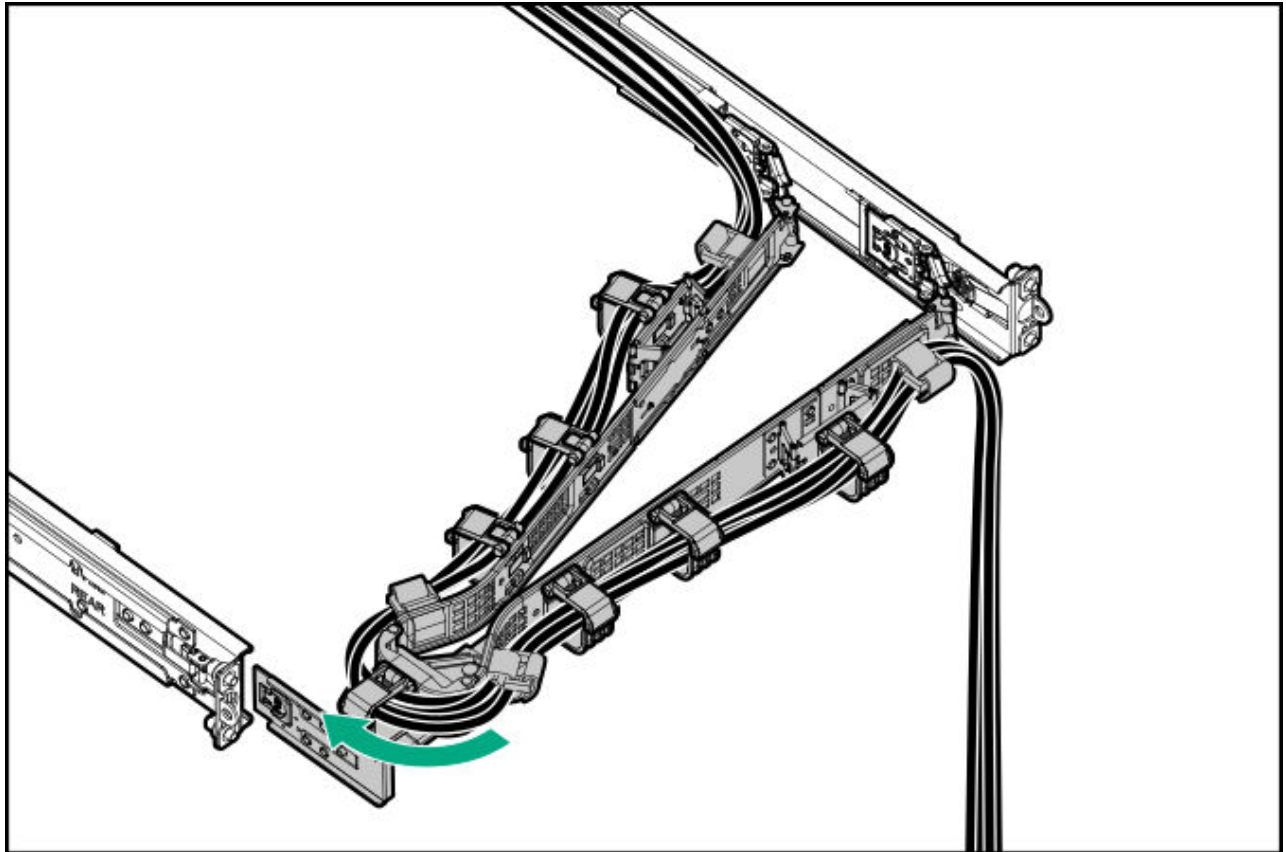

9. Power up the server.

10. If removed, install the front bezel.

Results

The installation procedure is complete.

PCIe riser option

Subtopics

Installing a riser board in the secondary riser cage

Installing a riser board in the secondary riser cage

Prerequisites

Before you perform this procedure, make sure that you have a T-15 Torx screwdriver available.

Procedure

1. Power down the server.
2. If installed, open the cable management arm.
3. Remove all power:
 - a. Disconnect each power cord from the power source.
 - b. Disconnect each power cord from the server.
4. Disconnect all peripheral cables from the server.
5. Remove the server from the rack.
6. Place the server on a flat, level work surface.
7. Remove the access panel.
8. Remove the secondary riser cage.
9. Install the secondary riser board:
 - a. Attach the riser board to the cage.
 - b. Install the riser board screws.

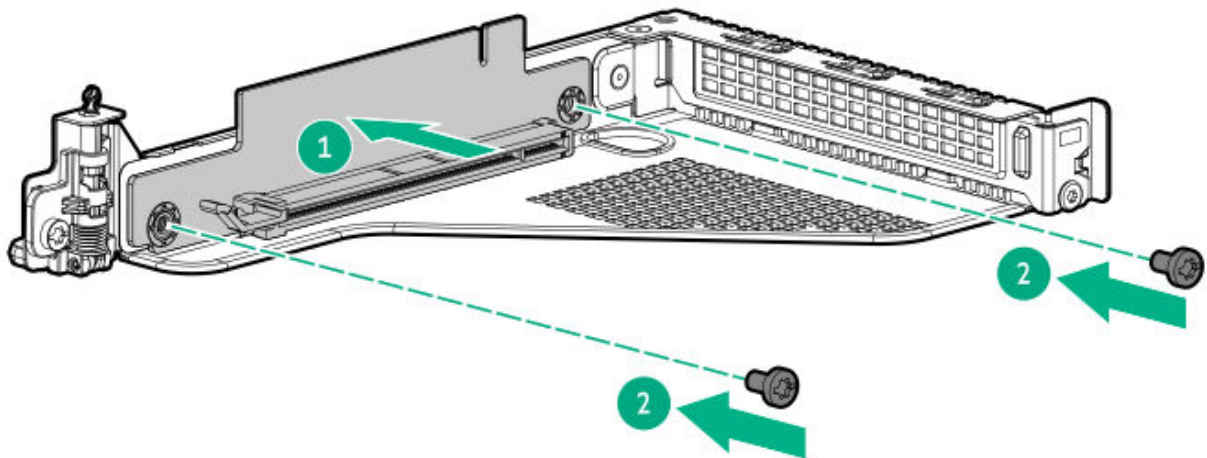

- .0. Install the secondary riser cage.
- .1. Connect the cables to the system board.
- .2. Install the access panel.
- .3. Install the server into the rack.
- .4. Connect all peripheral cables to the server.
- .5. Connect the power cords:
 - a. Connect each power cord to the server.
 - b. Connect each power cord to the power source.
- .6. If installed, close the cable management arm.

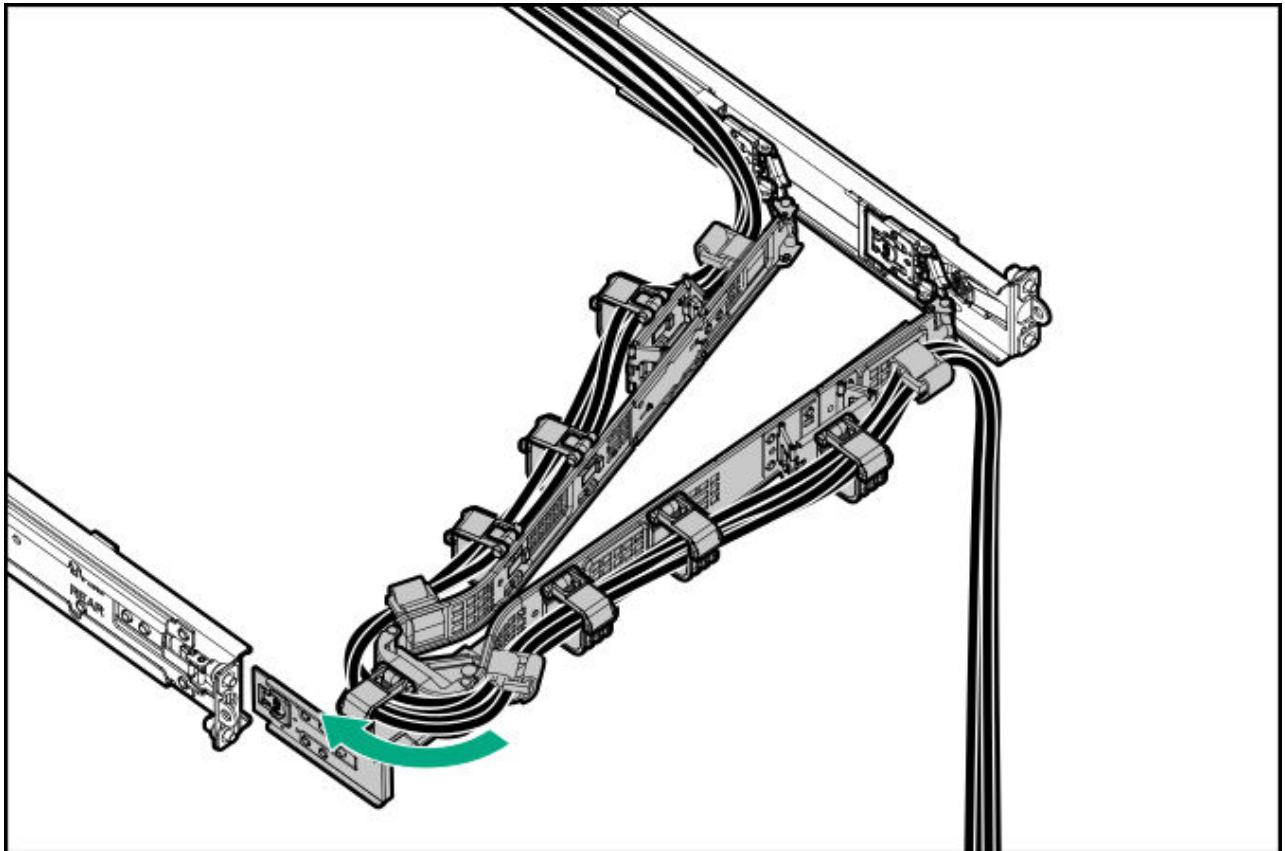

- .7. Power up the server.

Results

The installation procedure is complete.

Power supply options

Depending on the installed options and the regional location where the server was purchased, the server can be configured with one of the supported [power supplies](#).

Subtopics

[**Power supply warnings and cautions**](#)

[**DC power supply warnings and cautions**](#)

[**DC power supply wire colors**](#)

[**Connecting a DC power cable to a DC power source**](#)

[**Installing a DC power supply**](#)

[**Installing an AC power supply**](#)

Power supply warnings and cautions



WARNING

To reduce the risk of electric shock or damage to the equipment:

- Do not disable the power cord grounding plug. The grounding plug is an important safety feature.
- Plug the power cord into a grounded (earthed) electrical outlet that is easily accessible at all times.
- Unplug the power cord from the power supply to disconnect power to the equipment.
- Do not route the power cord where it can be walked on or pinched by items placed against it. Pay particular attention to the plug, electrical outlet, and the point where the cord extends from the server.



WARNING

To reduce the risk of injury from electric shock hazards, do not open power supplies. Refer all maintenance, upgrades, and servicing to qualified personnel.



CAUTION

Mixing different types of power supplies in the same server might:

- Limit or disable some power supply features including support for power redundancy.
- Cause the system to become unstable and might shut down.

To ensure access to all available features, all power supplies in the same server should have the same output and efficiency ratings. Verify that all power supplies have the same part number and label color.

DC power supply warnings and cautions



WARNING

To reduce the risk of electric shock or energy hazards:

- This equipment must be installed by trained service personnel.
- Connect the equipment to a reliably grounded secondary circuit source. A secondary circuit has no direct connection to a primary circuit and derives its power from a transformer, converter, or equivalent isolation device.
- The branch circuit overcurrent protection must be rated 27 A.



WARNING

To reduce the risk of electric shock, be sure that the cable grounding kit is properly installed and connected to a suitable protective earth terminal before connecting the power source to the rack.



CAUTION

This equipment is designed to permit the connection of the earthed conductor of the DC supply circuit to the earthing conductor at the equipment. If this connection is made, all the following must be met:

- This equipment must be connected directly to the DC supply system earthing electrode conductor or to a bonding jumper from an earthing terminal bar or bus to which the DC supply system earthing electrode conductor is connected.
- This equipment must be located in the same immediate area (such as adjacent cabinets) as any other equipment that has a connection between the earthed conductor of the same DC supply circuit and the earthing conductor, and also the point of earthing of the DC system. The DC system must be earthed elsewhere.
- The DC supply source is to be located within the same premises as the equipment.
- Switching or disconnecting devices must not be in the earthed circuit conductor between the DC source and the point of connection of the earthing electrode conductor.

DC power supply wire colors

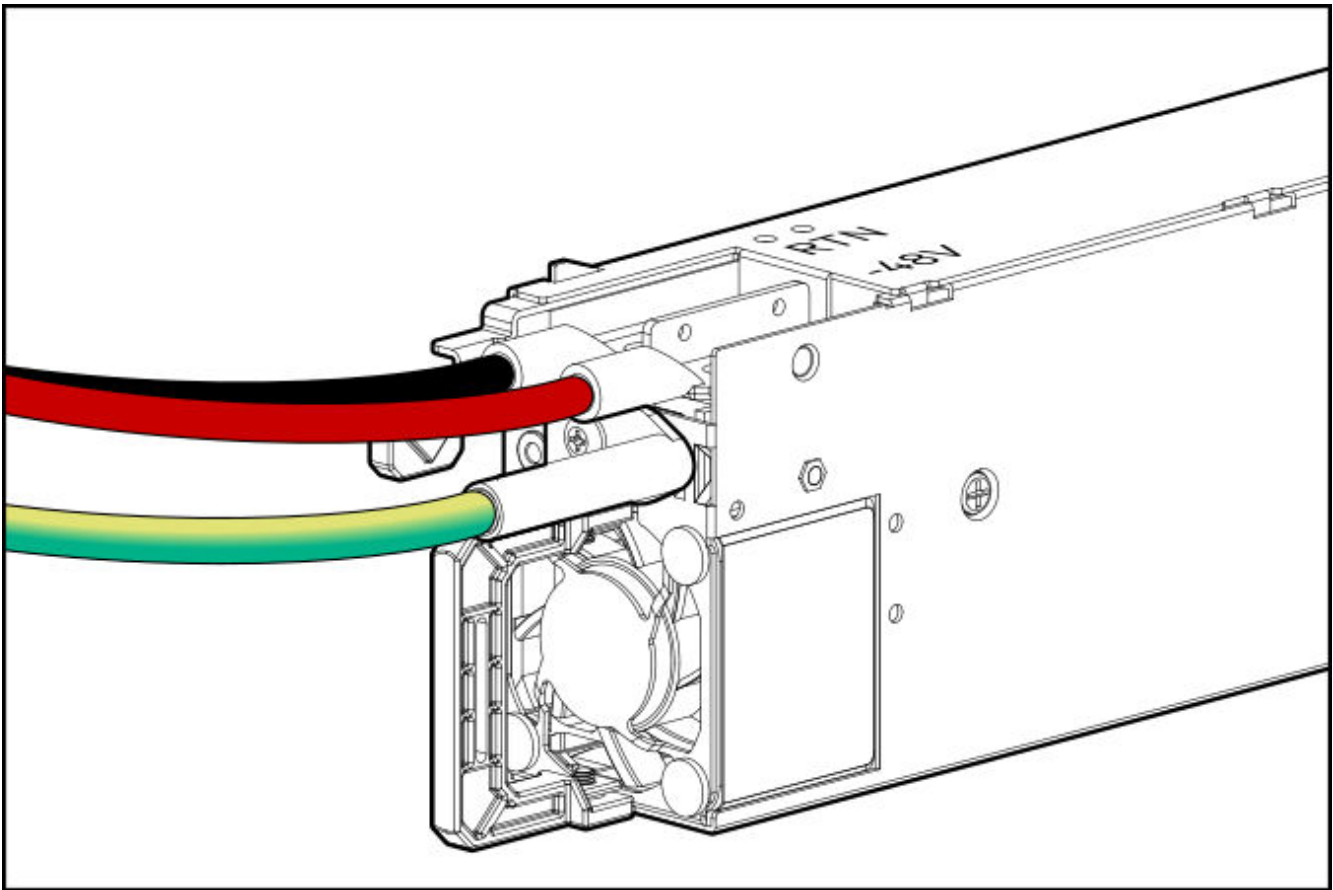

Wire color	Description	Wire slot
Red	Line wire	-48V
Black	Return wire	Return
Green + Yellow	Ground wire	Safety ground

Connecting a DC power cable to a DC power source

Prerequisites

Before you perform this procedure, make sure that you have the following items available:

- Electrical wire cutter

- Hand crimp tool

About this task



WARNING

To reduce the risk of electric shock or energy hazards:

- This equipment must be installed by trained service personnel and in accordance with local and regional electric codes and regulations
- Connect the equipment to a reliably grounded secondary circuit source. A secondary circuit has no direct connection to a primary circuit and derives its power from a transformer, converter, or equivalent isolation device.
- The overcurrent protection for the DC source must not exceed 45 A.



WARNING

When installing a DC power supply, the ground wire must be connected before the positive or negative leads.



WARNING

Remove power from the power supply before performing any installation steps or maintenance on the power supply.



CAUTION

The server equipment connects the earthed conductor of the DC supply circuit to the earthing conductor at the equipment. For more information, see the documentation that ships with the power supply.



CAUTION

If a DC connection exists between the earthed conductor of the DC supply circuit and the earthing conductor at the server equipment, the following conditions must be met:

- This equipment must be connected directly to the DC supply system earthing electrode conductor or to a bonding jumper from an earthing terminal bar or bus to which the DC supply system earthing electrode conductor is connected.
- Locate the equipment in the same immediate area (such as adjacent cabinets) as any other equipment that has a connection between the earthed conductor of the same DC supply circuit and the earthing conductor, and also the point of earthing of the DC system. The DC system must be earthed

Procedure

1. Cut the DC power cord ends no shorter than 150.00 cm (59.06 in).



IMPORTANT

The ring terminals must be UL approved and accommodate 6 AWG wires.



IMPORTANT

The minimum nominal thread diameter of a pillar or stud type terminal must be 3.50 mm (0.138 in). The diameter of a screw type terminal must be 5.00 mm (0.197 in).

2. If the power source requires ring tongues, use a crimping tool to install the ring tongues on the power cord wires and ground wire.
3. Stack each same-colored pair of wires and then attach them to the same power source.

For more information, see the documentation that ships with the power supply.

Installing a DC power supply

Prerequisites

- Before installing a power supply, review the following:
 - [Power supply warnings and cautions](#)
 - [DC power supply warnings and cautions](#)
 - [DC power supply wire colors](#)
- Before you perform this procedure, make sure that you have a Phillips No. 2 screwdriver available.
- Before connecting the power cables, review the following:
 - The optional P36877-B21 HPE lug kit can be purchased from an authorized HPE reseller for use with customer-supplied power cables. (The power cable and lug kit listed below can only be used with the 1600 W -48 VDC power supply.)
 - If you are using an input power cord option, the P22173-B21 HPE 1600 W DC PSU power cable kit can be purchased from an authorized HPE reseller.

- The DC power supply option kits do not ship with a Power Supply DC cable Kit and may not include a Power Supply Cable Lug kit. The optional DC Cable kit or the optional DC Cable Lug Kit may be purchased directly from Hewlett Packard Enterprise or an authorized HPE reseller. For additional information, see the power supply QuickSpecs at <https://www.hpe.com/info/fsps-qs>.

About this task

If you are not using an input power cord option, the power supply cabling must be made in consultation with a licensed electrician and be compliant with local code.



WARNING

To reduce the risk of electric shock, fire, and damage to the equipment, you must install this product in accordance with the following guidelines:

- The HPE 1600 W Flex Slot -48 VDC hot-plug power supply is intended only for installation in servers located in a restricted access location.
- The HPE 1600 W Flex Slot -48 VDC hot-plug power supply is not intended for direct connection to the DC supply branch circuit. Only connect this power supply to a power distribution unit (PDU) that provides an independent overcurrent-protected output for each DC power supply. Each output overcurrent-protected device in the PDU must be suitable for interrupting fault current available from the DC power source and must be rated no more than 45 A.
- The PDU output must have a shut-off switch or a circuit breaker to disconnect power for each power supply. To completely remove power from the power supply, disconnect power at the PDU. The end product may have multiple power supplies. To remove all power from the product, disconnect the power for each power supply.
- In accordance with applicable national requirements for Information Technology Equipment and Telecommunications Equipment, this power supply only connects to DC power sources that are classified as SELV or TNV. Generally, these requirements are based on the International Standard for Information Technology Equipment, IEC 60950-1/IEC 62368-1. In accordance with local and regional electric codes and regulations, the DC source must have one pole (Neutral/Return) reliably connected to earth ground.
- You must connect the power supply ground screw located on the front of the power supply to a suitable ground (earth) terminal. In accordance with local and regional electric codes and regulations, this terminal must be connected to a suitable building ground (earth) terminal. Do not rely on the rack or cabinet chassis to provide adequate ground (earth) continuity.



WARNING

To reduce the risk of personal injury from hot surfaces, allow the power supply, power supply blank, or dual slot power supply adapter to cool before touching it.

Procedure

1. Remove the protective cover from the power supply.

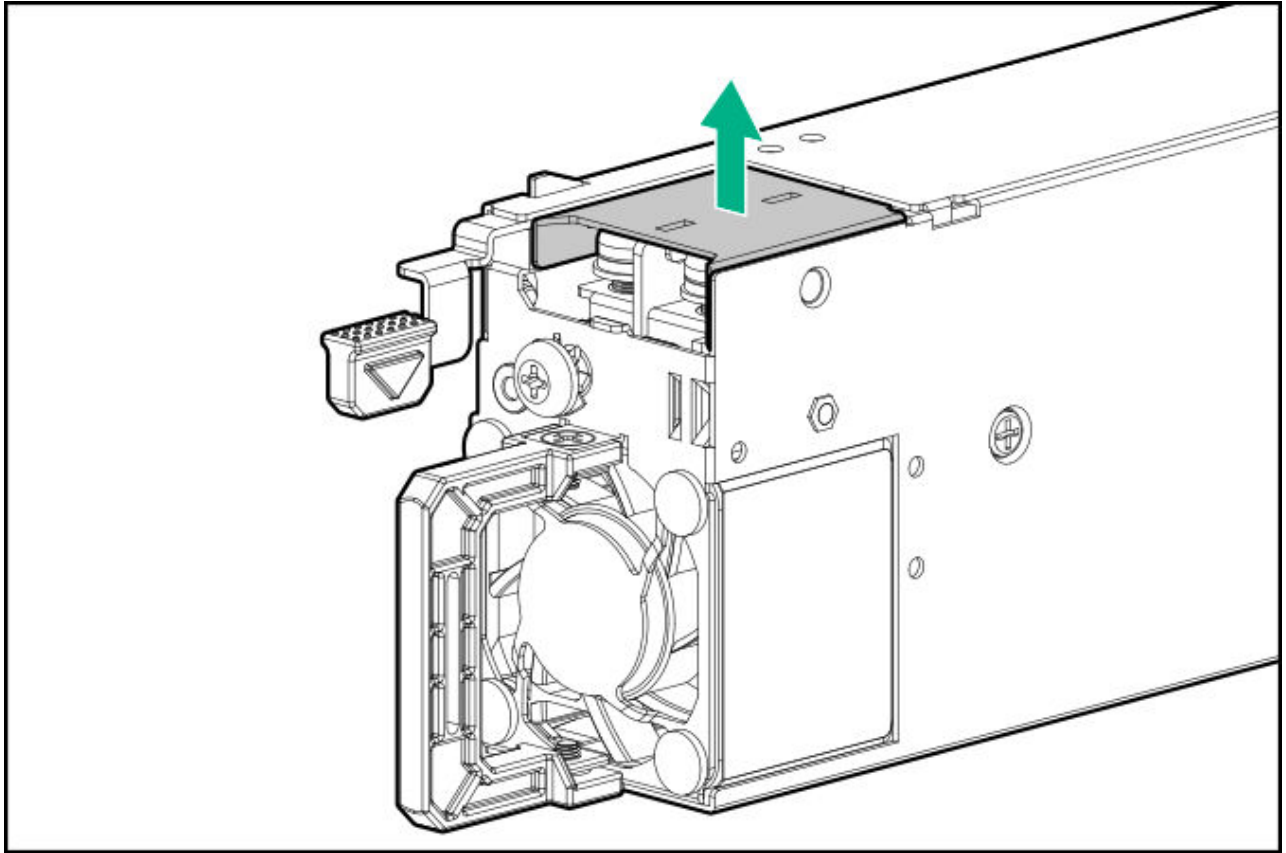

2. Remove the ground wire screw, and then remove the return wire and line wire screws.

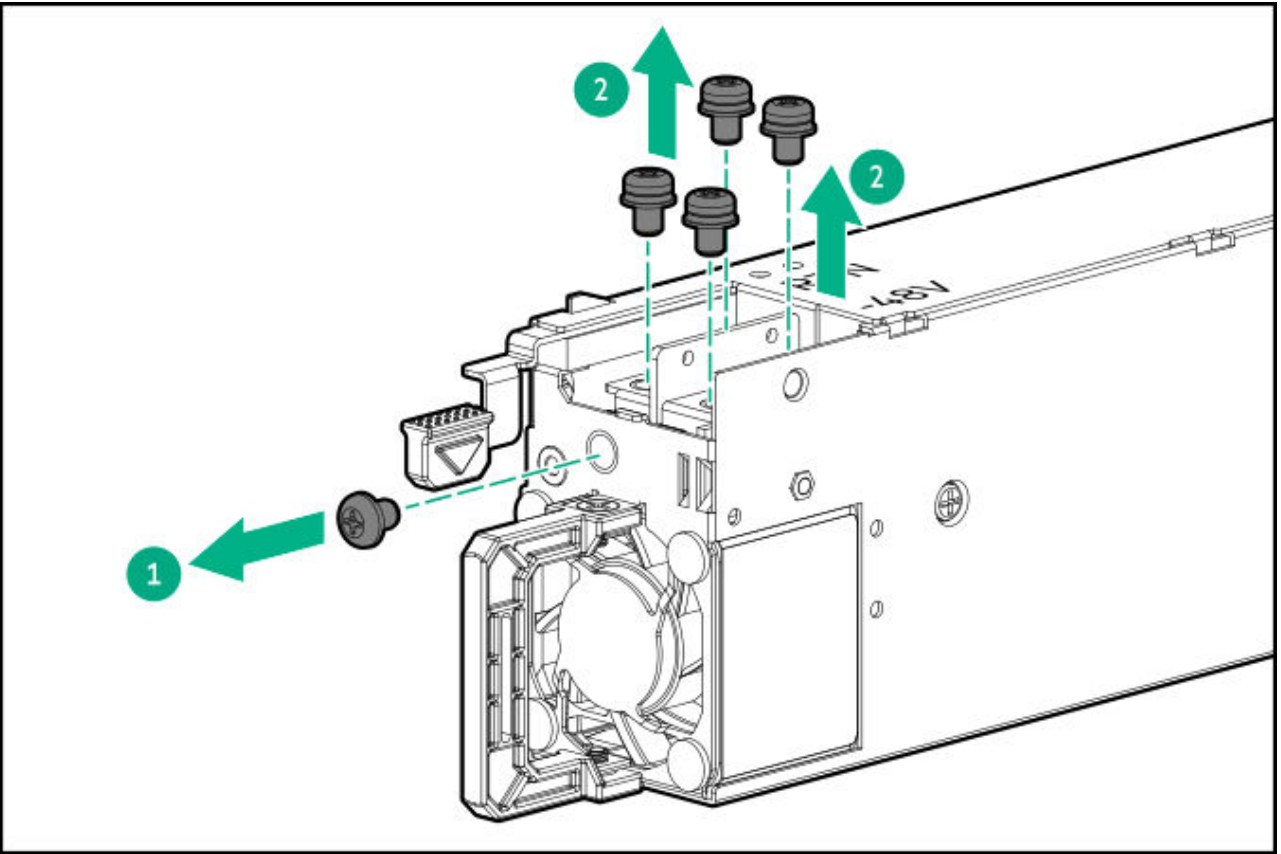

3. Attach the ground wire (green and yellow) to the DC power supply and tighten the screw and washer with 1.47 N-m (13 lbf-in).

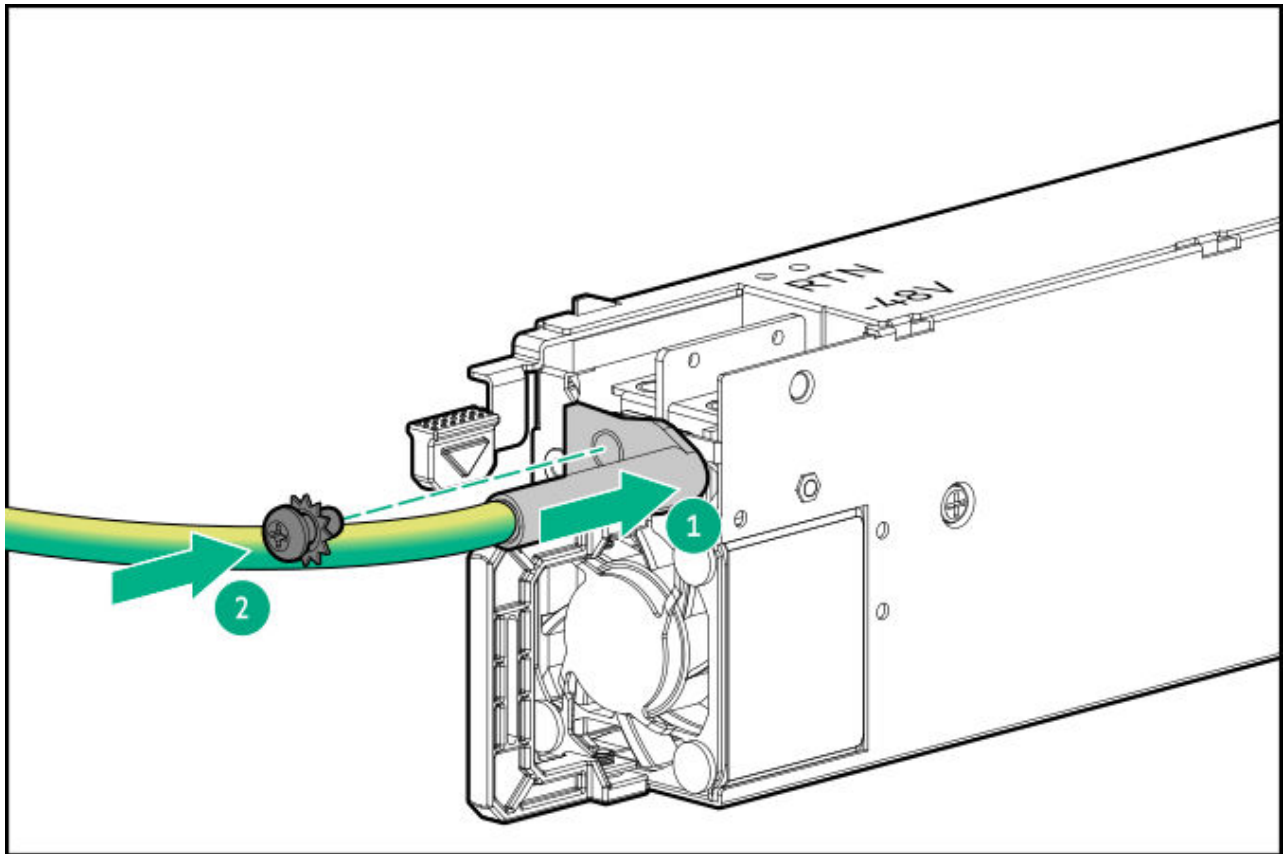

4. Install the return wire (black):

- a. Insert the return wire into the RTN slot on the DC power supply.
- b. Tighten the screw with 0.98 N-m (8.68 lbf-in).

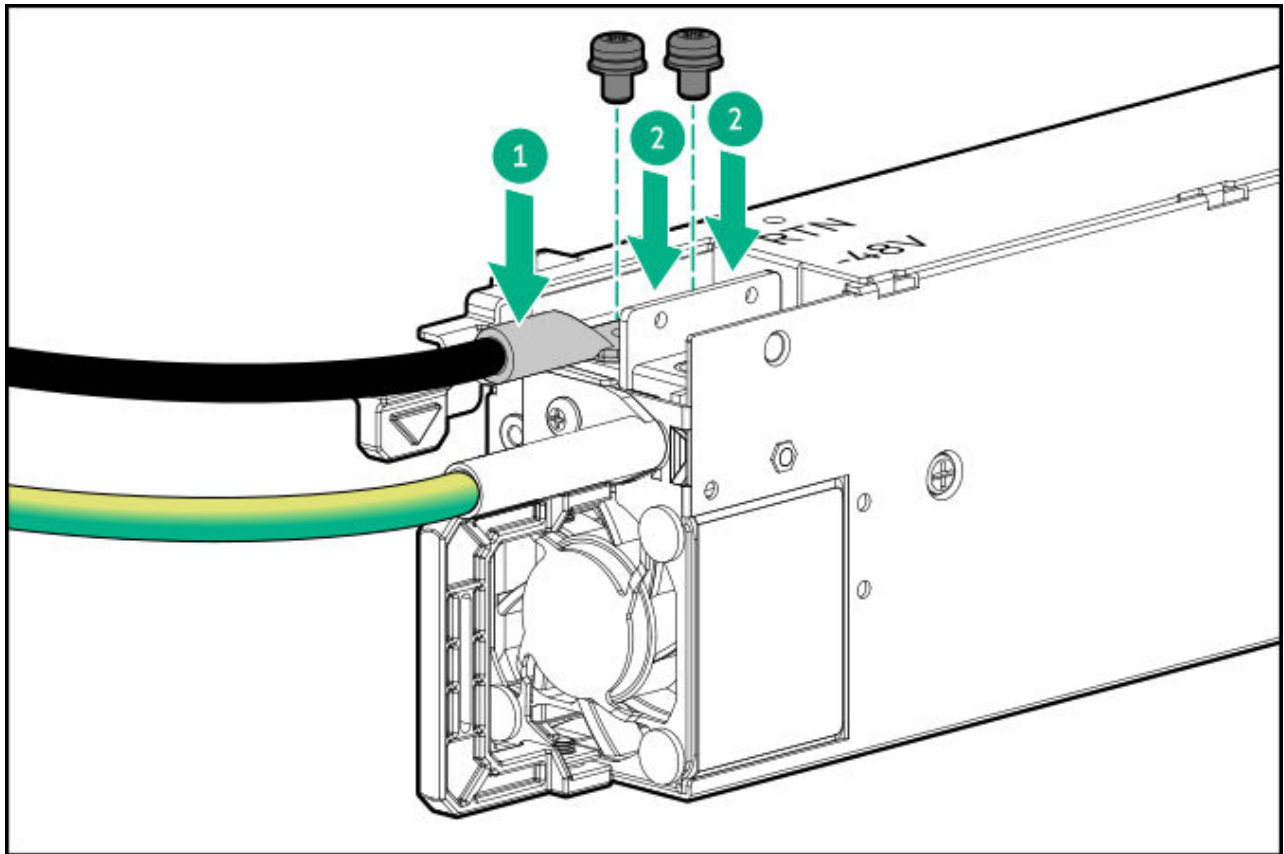

5. Install the line wire (red):

- a. Insert the line wire into the -48V slot on the DC power supply.
- b. Tighten the screw to 0.98 N-m (8.68 lbf-in).

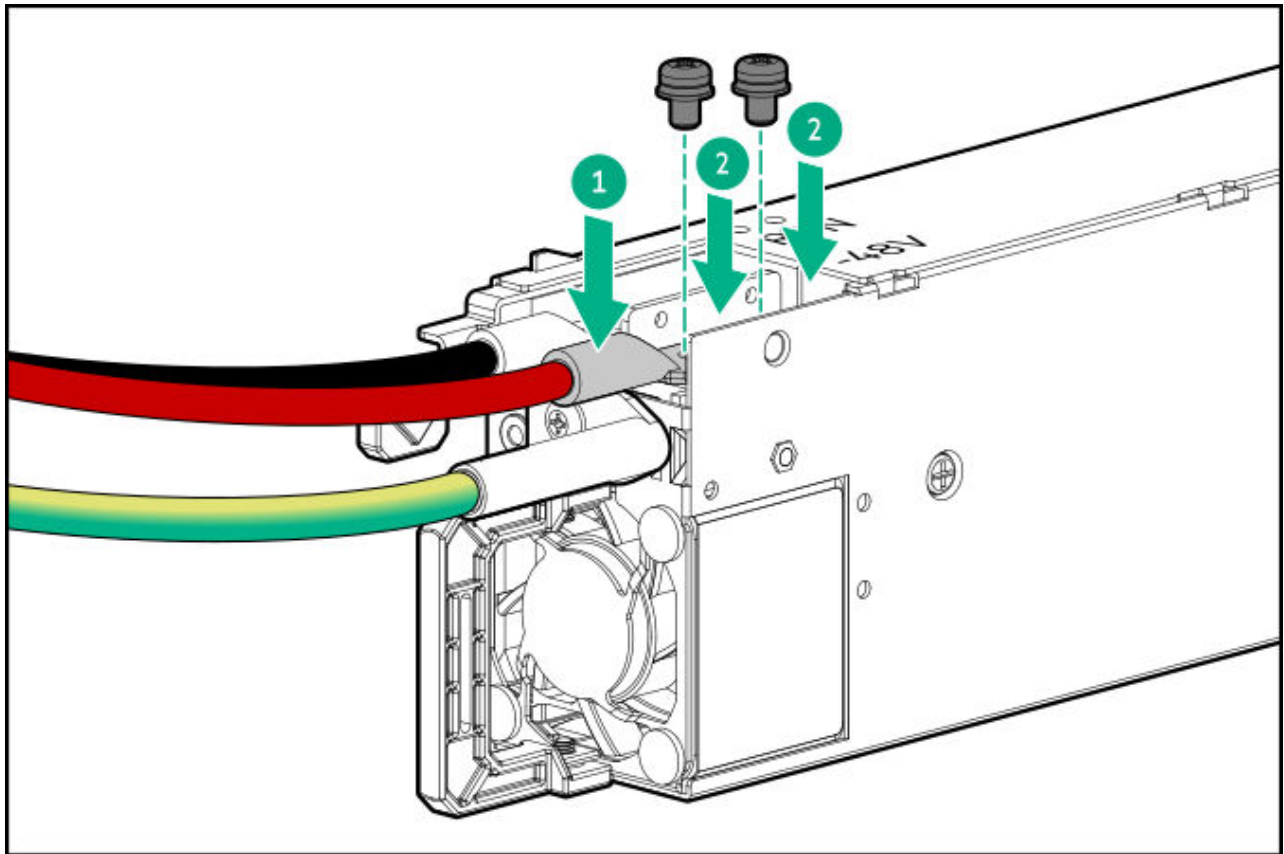

6. Install the protective cover on the DC power supply.

Make sure that the protective cover is locked.

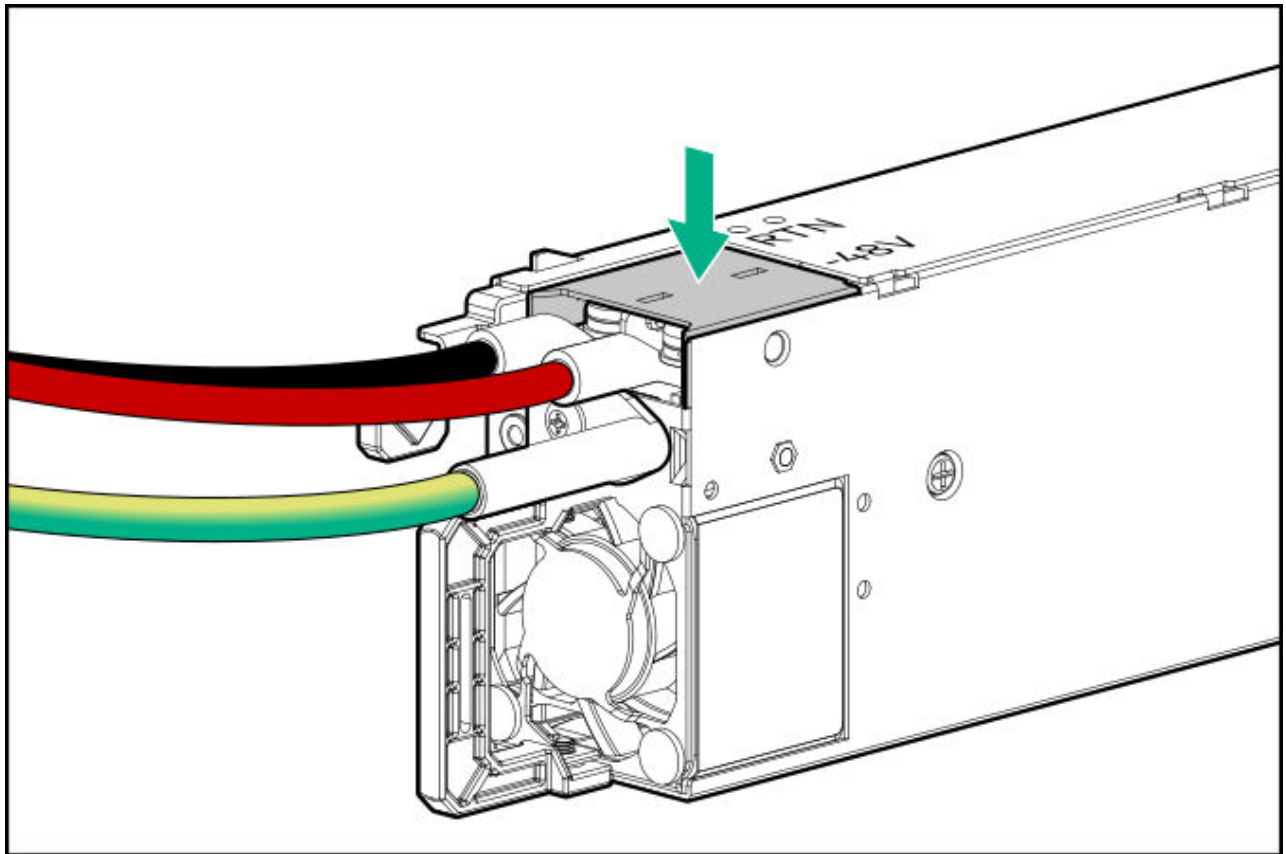

7. Secure the ground, positive return, and negative input wires in the strain relief strap.



CAUTION

Avoid tight bend radii to prevent damaging the internal wires of a power cord or a server cable. Never bend power cords and server cables tight enough to cause a crease in the sheathing.

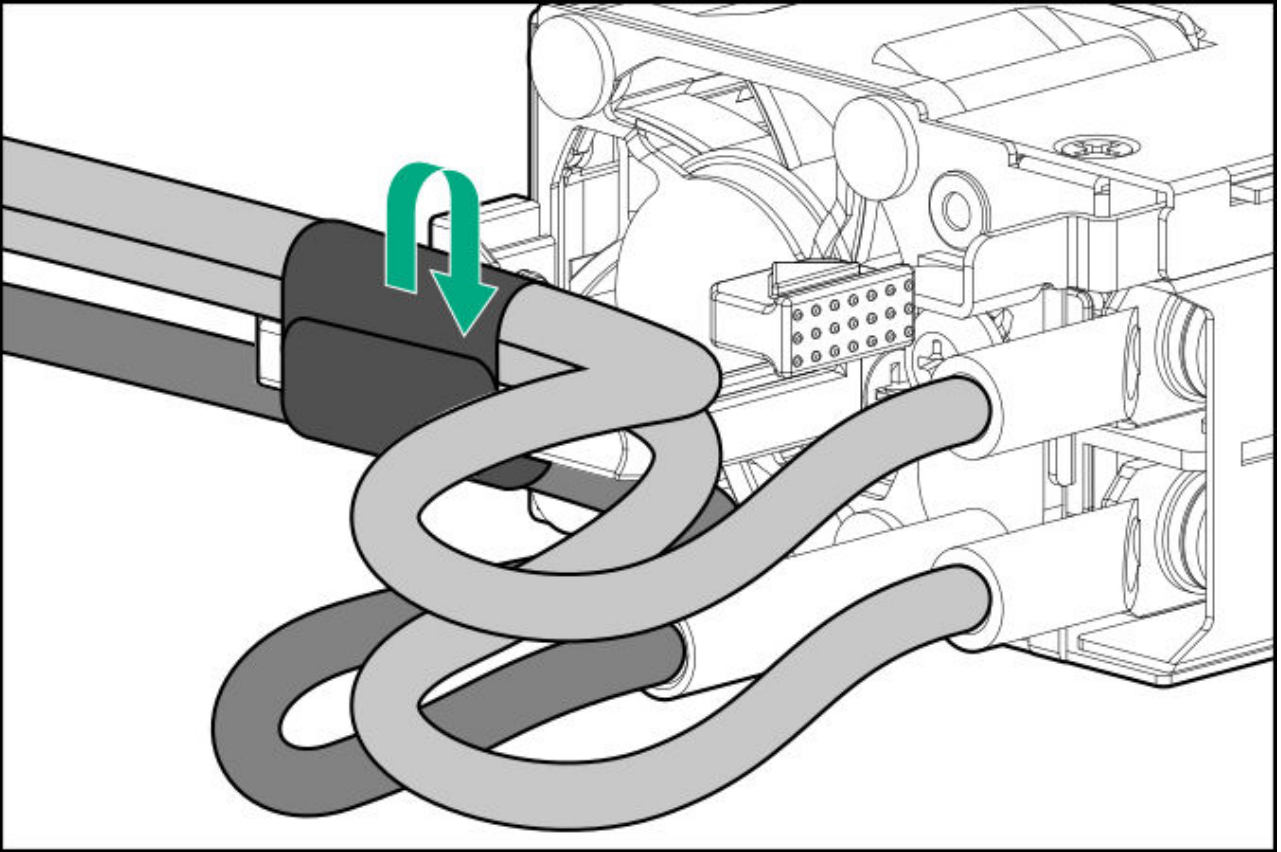

8. If you are installing a power supply in the power supply bay 2, remove the power supply blank.
Retain the blank for future use.

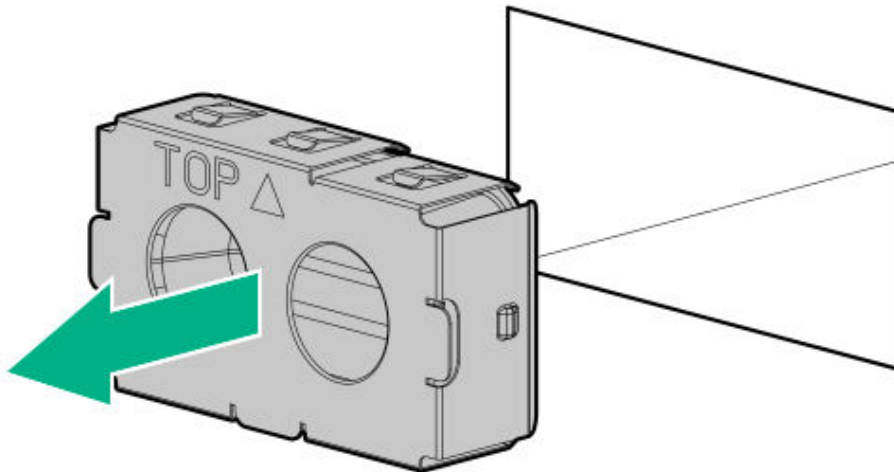

9. Immediately slide the power supply into the bay until it clicks into place.

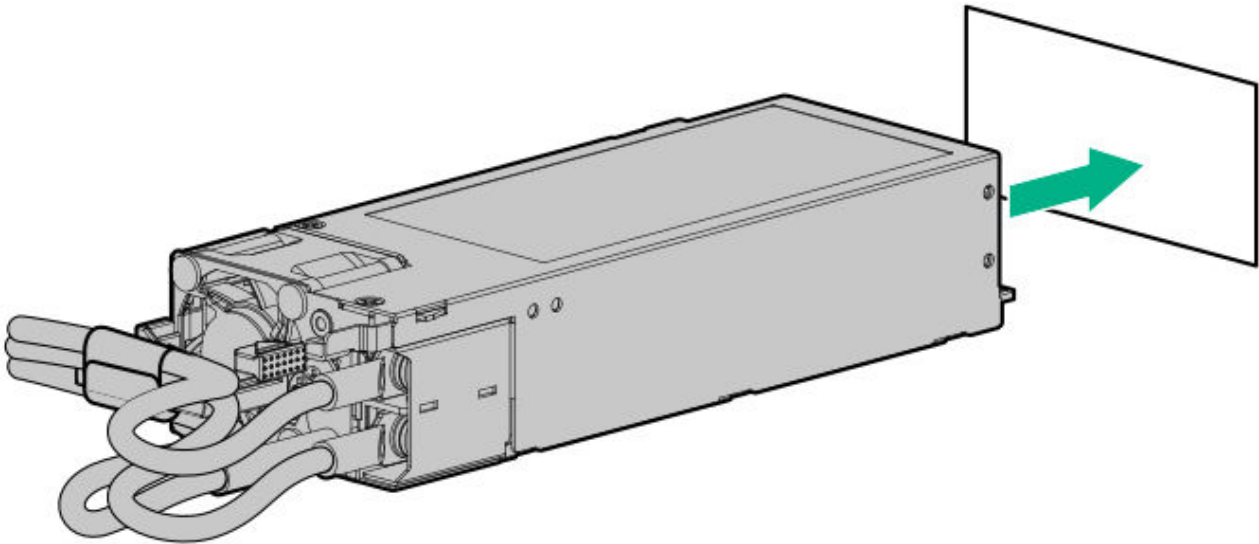

- .0. Make sure the -48 V DC power source is off or the PDU breaker is in the off position, and then connect the power cord to the -48 V DC power source or PDU.
- .1. Turn on the -48 V power source or switch the PDU breaker to the on position to supply -48 V to the power supply.
- .2. Connect a DC power cable to a DC power source.
- .3. Make sure that the power supply LED is green.

Results

The installation procedure is complete.

Installing an AC power supply

Prerequisites

Before installing a power supply option, review the [Power supply warnings and cautions.](#)

About this task



WARNING

To reduce the risk of personal injury from hot surfaces, allow the power supply, power supply blank, or dual slot power supply adapter to cool before touching it.



CAUTION

To prevent improper cooling and thermal damage, do not operate the server unless all bays are populated with either a component or a blank.

Procedure

1. Remove the power supply blank.

Retain the blank for future use.

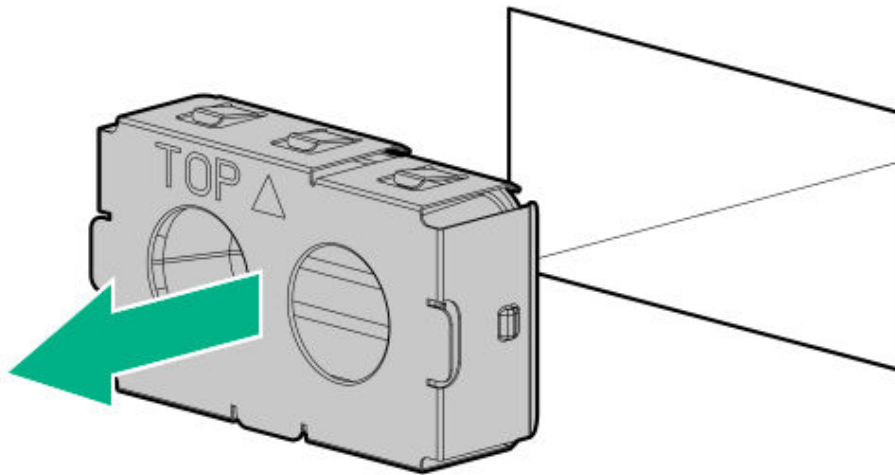

2. Install the power supply.

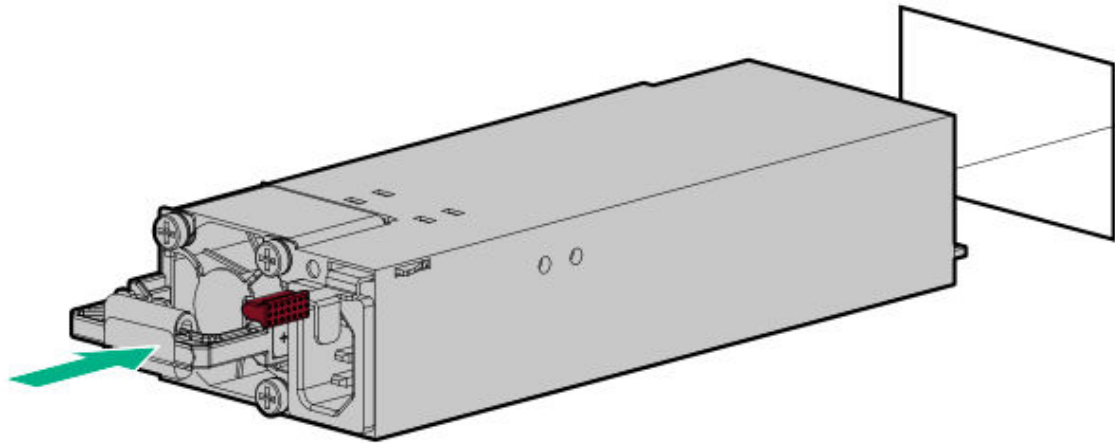

3. Connect the power cord to the power supply.
4. Secure the power cord.

**CAUTION**

Avoid tight bend radii to prevent damaging the internal wires of a power cord or a server cable. Never bend power cords and server cables tight enough to cause a crease in the sheathing.

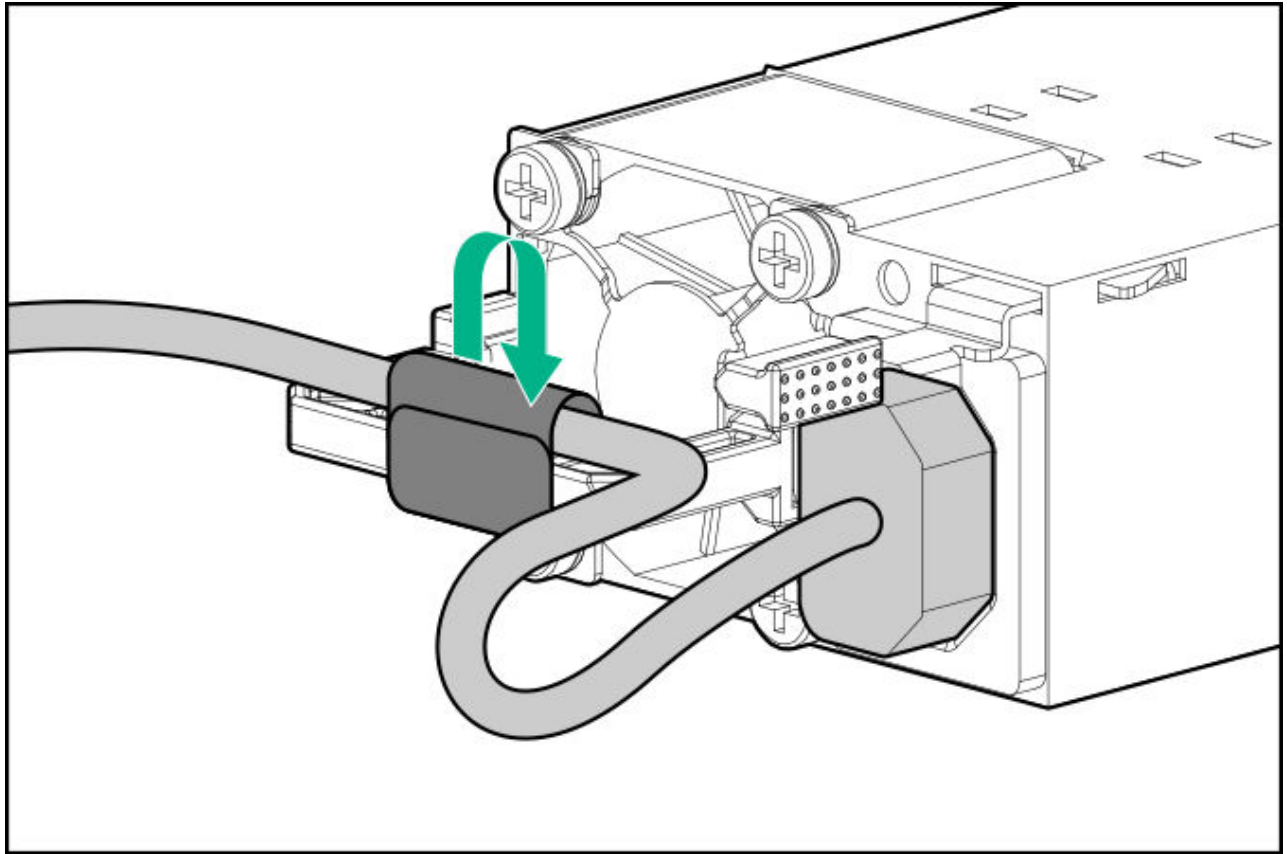

5. Connect the power cords:
 - a. Connect each power cord to the server.
 - b. Connect each power cord to the power source.
6. Make sure that the power supply LED is green.

Results

The installation procedure is complete.

Transceiver option

Transceivers serve as the connection between the adapter and the network cable for maintaining high-speed performance.

Subtopics

Transceiver warnings and cautions

Installing a transceiver

Transceiver warnings and cautions



WARNING

Fiber-optic transceivers and fiber-optic cables connected to transceivers emit laser light that can damage your eyes. To avoid eye injuries, avoid direct eye exposure to the beam from the fiber-optic transceiver or into the ends of fiber-optic cables when they are powered-up.



CAUTION

The presence of dust in transceiver ports can cause poor cable connectivity. To prevent dust from entering, install a dust plug in an unused transceiver port.



CAUTION

Supported transceivers can be hot-swapped—removed and installed while the server is powered-on. However, to prevent potential damage to the transceiver or the fiber-optic cable, disconnect the cable from the transceiver before hot-swapping it.



CAUTION

Do not remove and install transceivers more often than is necessary. Doing so can shorten the useful life of the transceiver.



IMPORTANT

When you replace a transceiver with another of a different type, the server might retain selected port-specific configuration settings that were configured for the replaced transceiver. Be sure to validate or reconfigure port settings as required.

Installing a transceiver

Prerequisites

Before installing a transceiver option, review the following:

- [Transceiver warnings and cautions](#)
- Transceiver documentation for specific operational and cabling requirements

Procedure

1. Hold the transceiver by its sides and gently insert it into the network adapter port until it clicks into place.

Transceivers are keyed so that they can only be inserted in the correct orientation. If the transceiver does not fit easily into the port, you might have positioned it incorrectly. Reverse the orientation of the transceiver and insert it again.

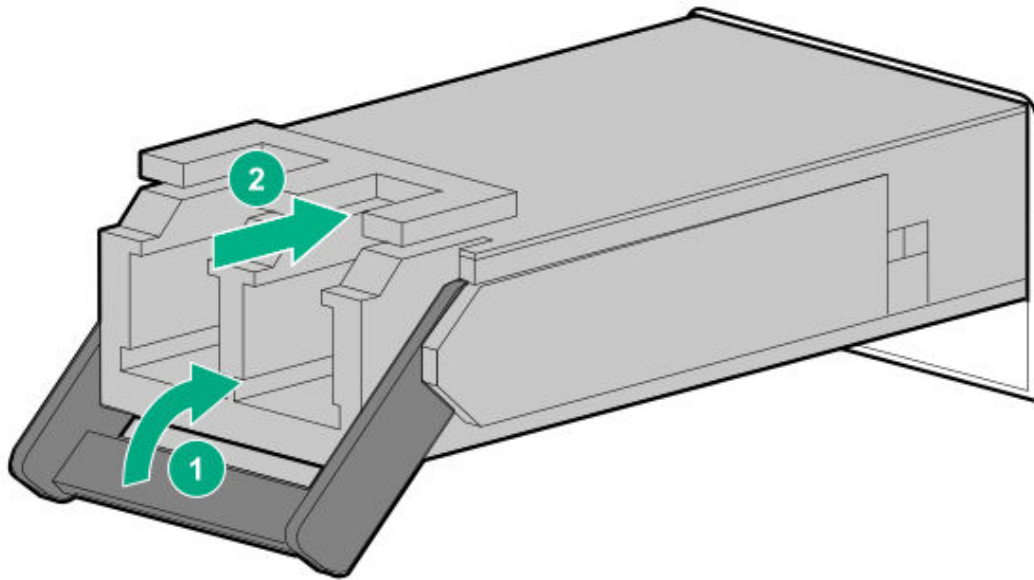

2. Remove the dust plug or protective cover from the transceiver.
3. Connect a compatible LAN segment cable to the transceiver.
4. Make sure that the NIC link LED on the port is solid green.

For more information on the port LED behavior, see the documentation that ships with the transceiver.

5. If needed, see the transceiver documentation for the model-specific fastening mechanism applicable to the transceiver.

Results

The installation procedure is complete.

Fan options



CAUTION

To avoid damage to the equipment, do not operate the server for extended periods of time if the server does not have the optimal number of fans installed. Although the server might boot, we do not recommend operating the server without the required fans installed and operating.

The server supports standard and high performance fans. Use the following tables to identify the valid fan configurations.

Table 1. Standard fan configuration

Drive configuration	Fan bay 1	Fan bay 2	Fan bay 3	Fan bay 4	Fan bay 5	Fan bay 6	Fan bay 7
4 LFF	Optional	Optional	Fan	Fan	Fan	Fan	Fan
8 SFF	Optional	Optional	Fan	Fan	Fan	Fan	Fan

Table 2. High performance fan configuration

Drive configuration	Fan bay 1	Fan bay 2	Fan bay 3	Fan bay 4	Fan bay 5	Fan bay 6	Fan bay 7
4 LFF	Fan	Fan	Fan	Fan	Fan	Fan	Fan
12 LFF	Fan	Fan	Fan	Fan	Fan	Fan	Fan
8 SFF	Fan	Fan	Fan	Fan	Fan	Fan	Fan

The server supports variable fan speeds. The fans operate at minimum speed until a temperature change requires a fan speed increase to cool the server. The server shuts down during the following temperature-related scenarios:

- At POST and in the OS, iLO 6 performs an orderly shutdown if a cautionary temperature level is detected. If the server hardware detects a critical temperature level before an orderly shutdown occurs, the server performs an immediate shutdown.
- When the Thermal Shutdown feature is disabled in the BIOS/Platform Configuration (RBSU), iLO 6 does not perform an orderly shutdown when a cautionary temperature level is detected. Disabling this feature does not disable the server hardware from performing an immediate shutdown when a critical temperature level is detected.



CAUTION

A thermal event can damage server components when the Thermal Shutdown feature is disabled in the BIOS/Platform Configuration (RBSU).

Subtopics

Fan mode behavior

Installing a fan

Fan mode behavior

The seven fan setup provides redundant fan support. In redundant fan mode, if a fan rotor failure occurs:

- The system switches to nonredundant fan mode. The system continues to operate in this mode.
- The system Health LED flashes amber.

If a second fan rotor failure or a missing fan occurs, the operating system gracefully shuts down.

Installing a fan

About this task



IMPORTANT

After removing a high-performance (dual-rotor) fan, install or replace the fan within 60 seconds. Otherwise, the server will shut down gracefully.

Procedure

1. If installed, open the cable management arm.
2. Do one of the following:
 - a. Extend the server from the rack.
 - b. Remove the server from the rack.
3. Remove the access panel.
4. Remove the M.2 air baffle.
5. Remove fan blanks from the fan bays, if installed.

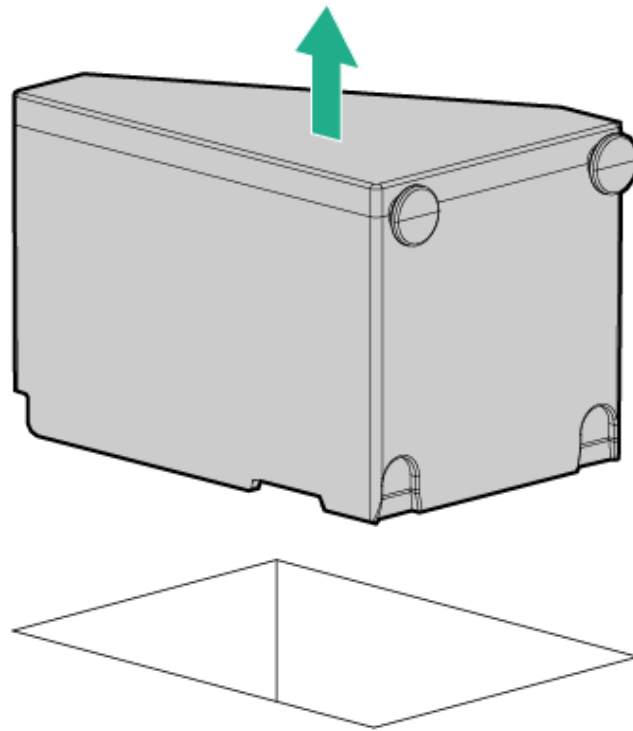

6. Install a fan.

Press the fan connector to make sure the fan is firmly seated on the fan board.

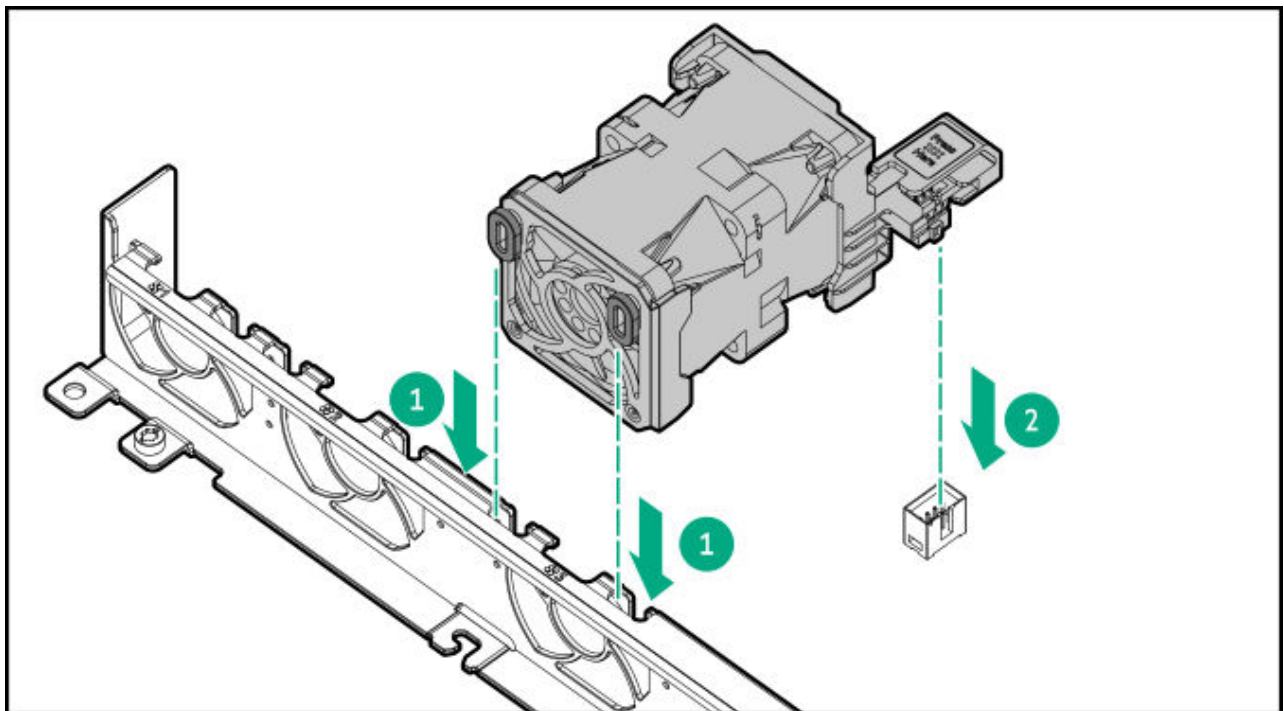

7. Install the M.2 air baffle.
8. Install the access panel.
9. Install the server into the rack.
10. If installed, close the cable management arm.

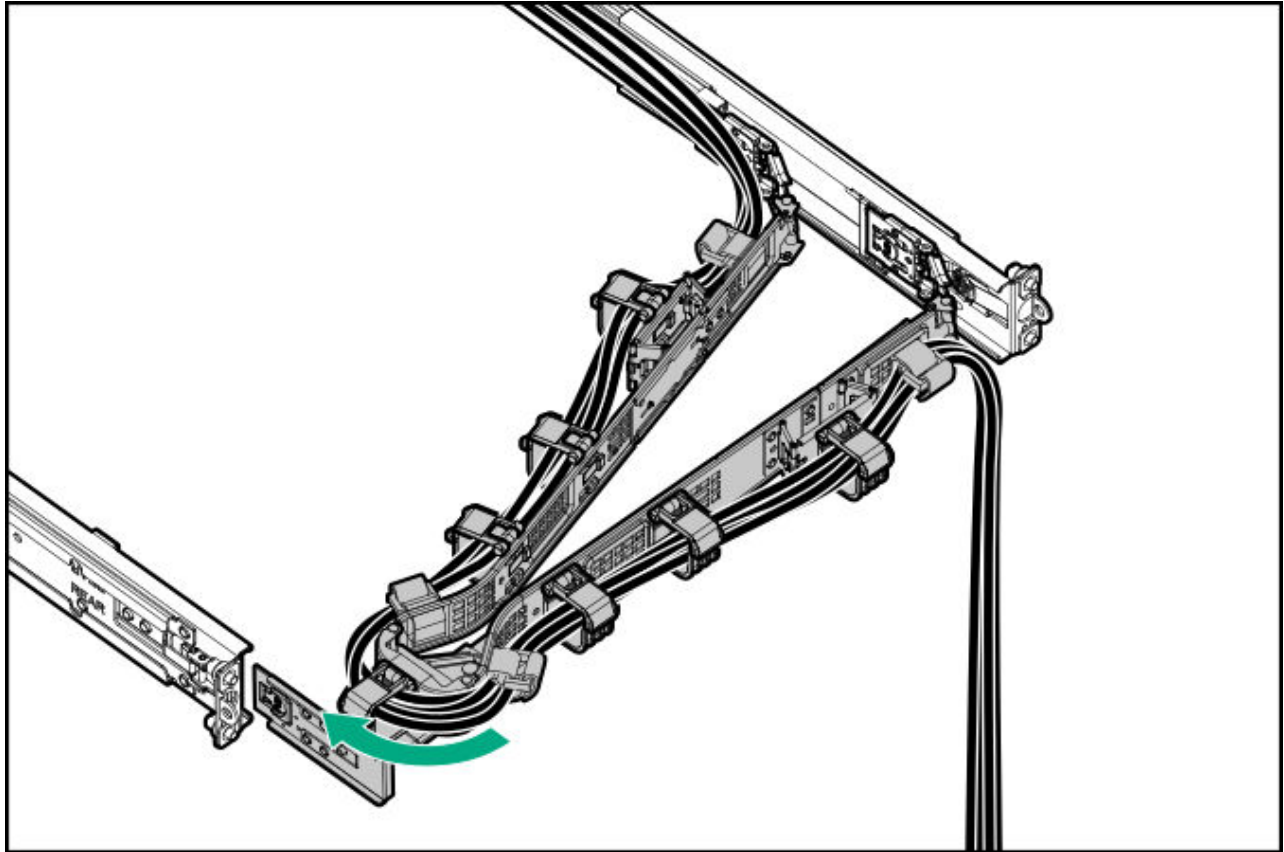

Results

The installation procedure is complete.

Expansion card options

The server supports the installation of full-height, half-length and half-height, half-length (low profile) PCIe expansion / add-in (AIC) cards such as:

- HPE type-p storage controller
- Ethernet adapter
- HDR InfiniBand adapter

- Fibre channel host bus adapter (FC HBA)
- Accelerator (workload, computational, or graphics accelerator)

For more information on the expansion options validated for this server, see the server QuickSpecs on the Hewlett Packard Enterprise website:

<https://www.hpe.com/info/quickspecs>

Subtopics

Installing an expansion card

Installing an expansion card

Prerequisites

Before you perform this procedure, make sure that you have the following items available:

- T-10 Torx screwdriver

About this task



CAUTION

To prevent improper cooling and thermal damage, do not operate the server unless all PCIe slots have either a riser slot blank or an expansion card installed.



CAUTION

A discharge of static electricity from a finger or other conductor might damage system boards or other static-sensitive devices. To prevent damage, observe antistatic precautions.

Procedure

1. Power down the server.
2. If installed, open the cable management arm.
3. Remove all power:
 - a. Disconnect each power cord from the power source.
 - b. Disconnect each power cord from the server.
4. Disconnect all peripheral cables from the server.

5. Remove the server from the rack.
6. Place the server on a flat, level work surface.
7. Remove the access panel.
8. Remove the riser cage.
9. Remove the riser slot blank.
Retain the blank for future use.

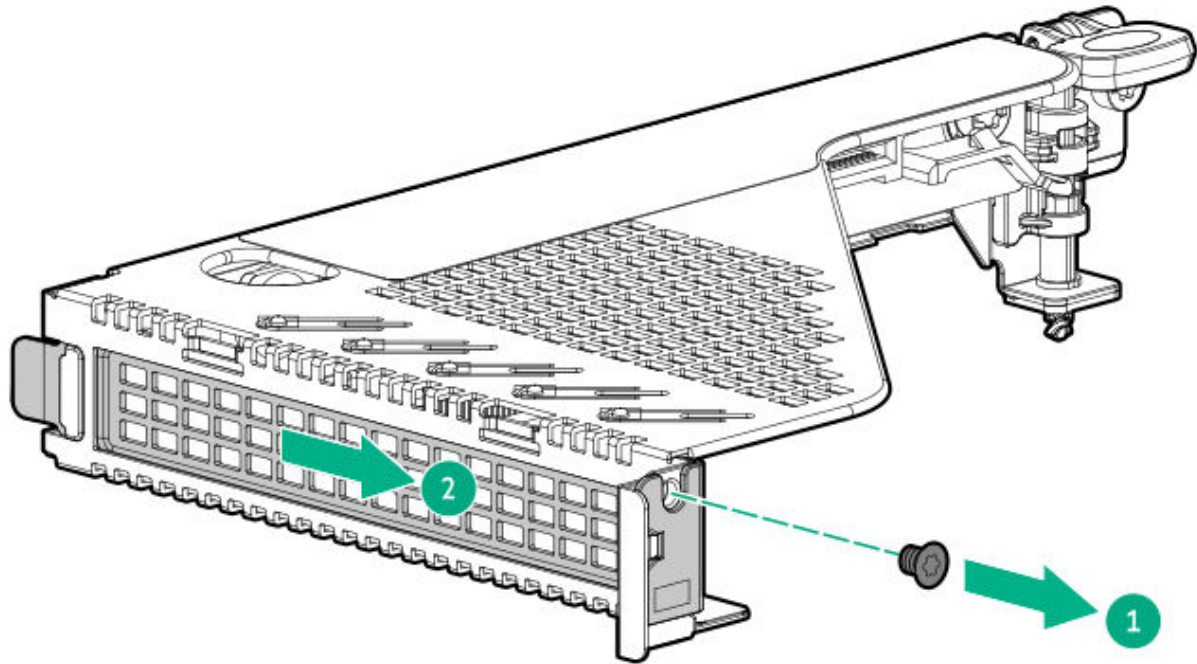

- .0. Make sure that any switches or jumpers on the expansion card are set properly.
For more information, see the documentation that ships with the expansion card option.
- .1. Install the expansion card:
Make sure that the expansion card is seated firmly in the slot.

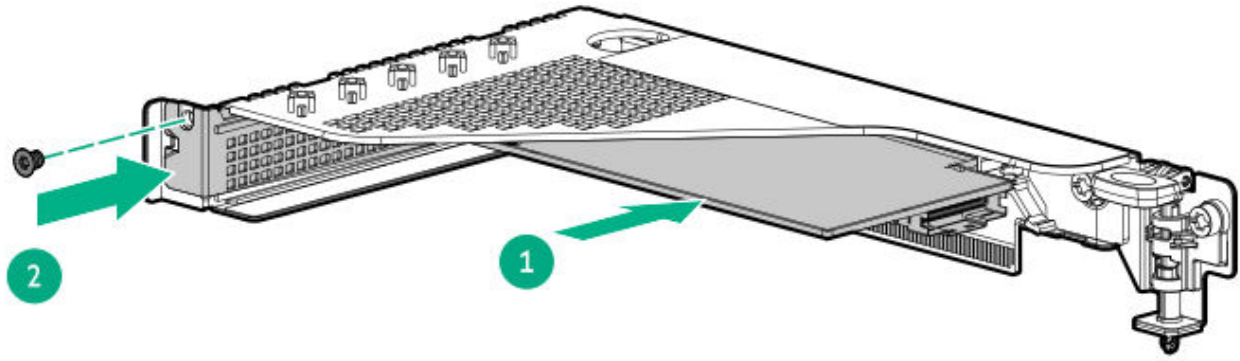

- .2. Connect all necessary internal cabling to the expansion card.

For more information on these cabling requirements, see the documentation that ships with the option.

- .3. Install the riser cage.
- .4. Install the access panel.
- .5. Install the server into the rack.
- .6. Connect all peripheral cables to the server.
- .7. Connect the power cords:
 - a. Connect each power cord to the server.
 - b. Connect each power cord to the power source.
- .8. If installed, close the cable management arm.

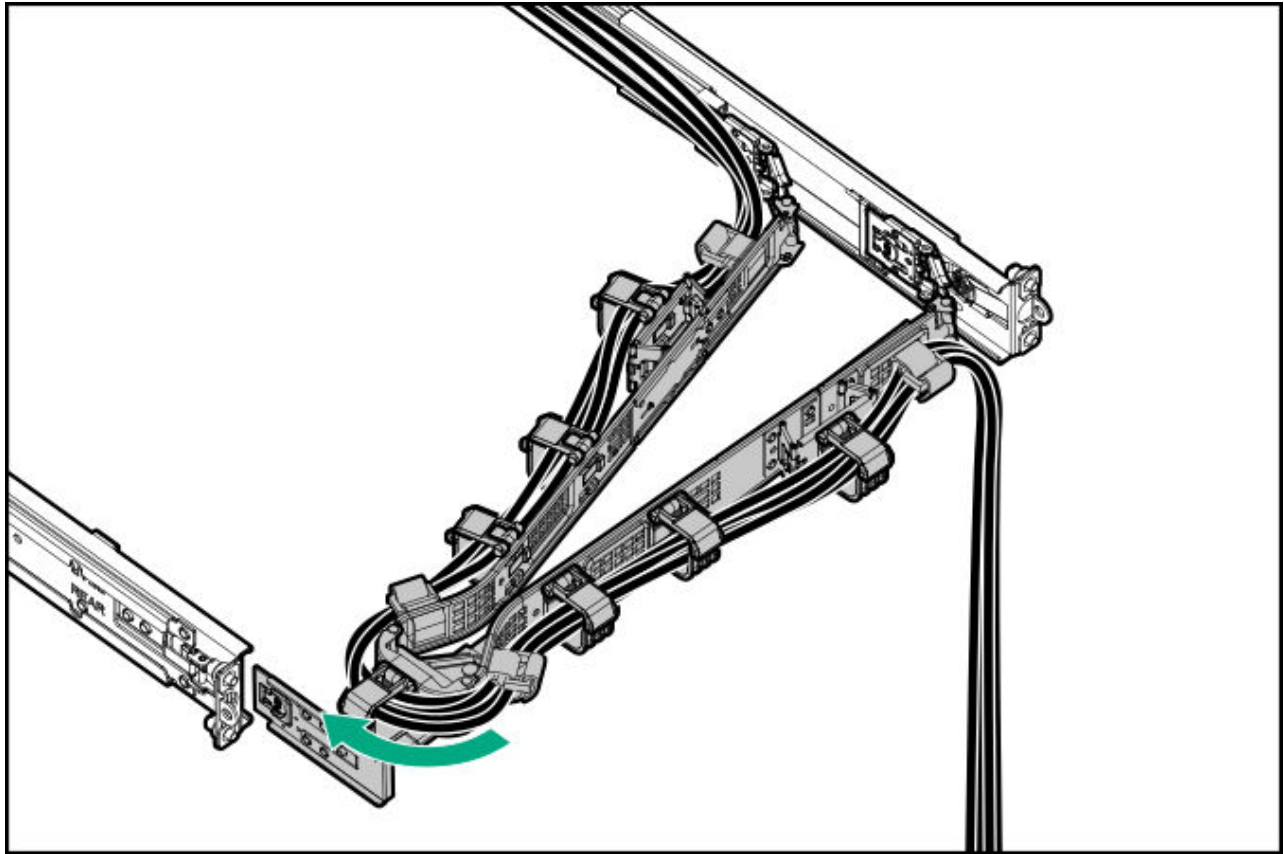

9. Power up the server.

Results

The installation procedure is complete.

GPU options

This server supports various GPU options to meet your computational and graphics workload requirements. For a list of supported GPU models, see the server QuickSpecs on the Hewlett Packard Enterprise website (<https://www.hpe.com/info/quickspecs>).

- PCIe workload GPUs—These options are PCIe card-based, direct-attach solutions that use solid-state storage technology directly on the PCI bus to boost I/O performance and reduce latency to scale in line with your processing requirements.
- Computational and graphics GPUs—These options deliver accelerated compute performance for a range of deep learning, high-performance computing (HPC), and graphics-intensive applications.

Subtopics

Installing an accelerator in the GPU riser cage

Prerequisites

Before installing this option, do the following:

- Be sure that the power supplies support the installation of this option. For more information, see the **Hewlett Packard Enterprise Configurator website**.
- Before you perform this procedure, make sure that you have a T-15 Torx screwdriver available.

About this task



WARNING

To reduce the risk of personal injury from hot surfaces, allow the drives and the internal system components to cool before touching them.



CAUTION

To prevent damage to electrical components, properly ground the server before beginning any installation procedure. Improper grounding can cause electrostatic discharge.

- One single-width accelerator is supported in slot 4.
- Two single-width accelerators and double-width accelerators are supported in slots 4 and 5.
- Four single-width accelerators are supported in all four slots.

Procedure

1. Back up all server data.
2. Power down the server.
3. If installed, open the cable management arm.
4. Remove all power:
 - a. Disconnect each power cord from the power source.
 - b. Disconnect each power cord from the server.
5. Disconnect all peripheral cables from the server.

6. Remove the server from the rack.
 7. Place the server on a flat, level work surface.
 8. Remove the access panel.
 9. Remove the middle cover.
 0. Remove the GPU riser cage.
 - .1. Remove the GPU riser slot blank:
 - a. Loosen the captive screws on the GPU bracket retainer.
 - b. Remove the GPU bracket retainer.
 - c. Remove the riser slot blank from the GPU riser cage.
- Single-width accelerator

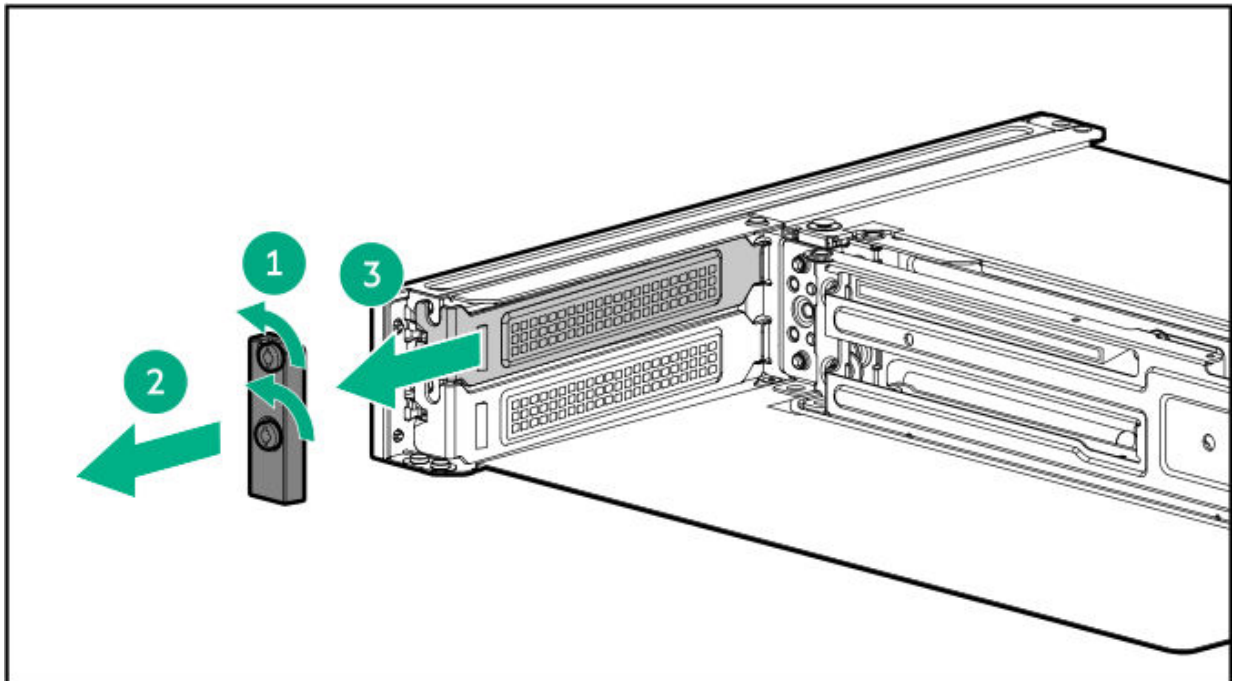

- Double-width accelerator

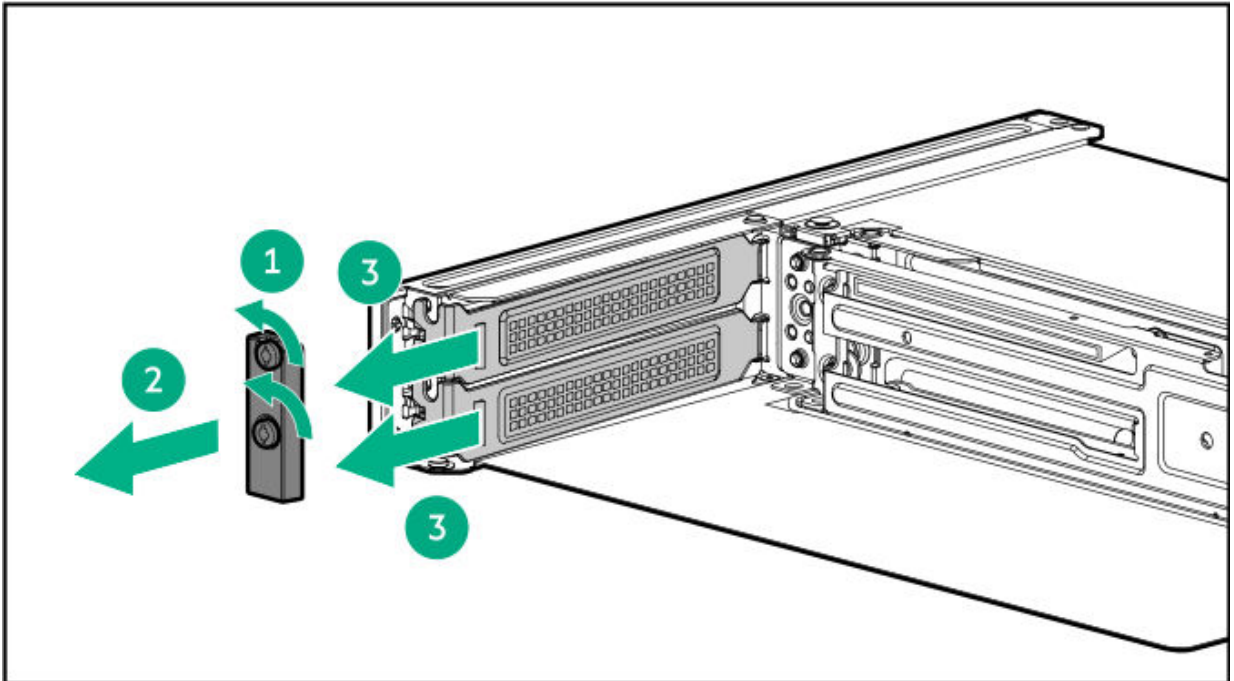

.2. Install the accelerator:

- a. Plug in the accelerator to the GPU riser.

Make sure that the accelerator is firmly seated in the riser slot.

- b. Attach the GPU bracket retainer.

- c. Tighten the captive screws.

- Single-width accelerator

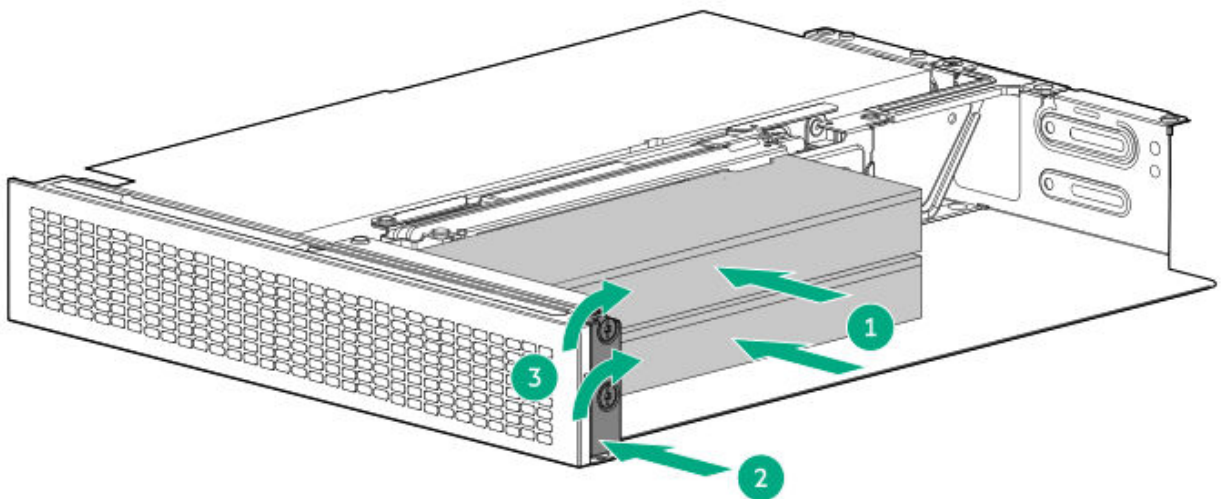

- Double-width accelerator

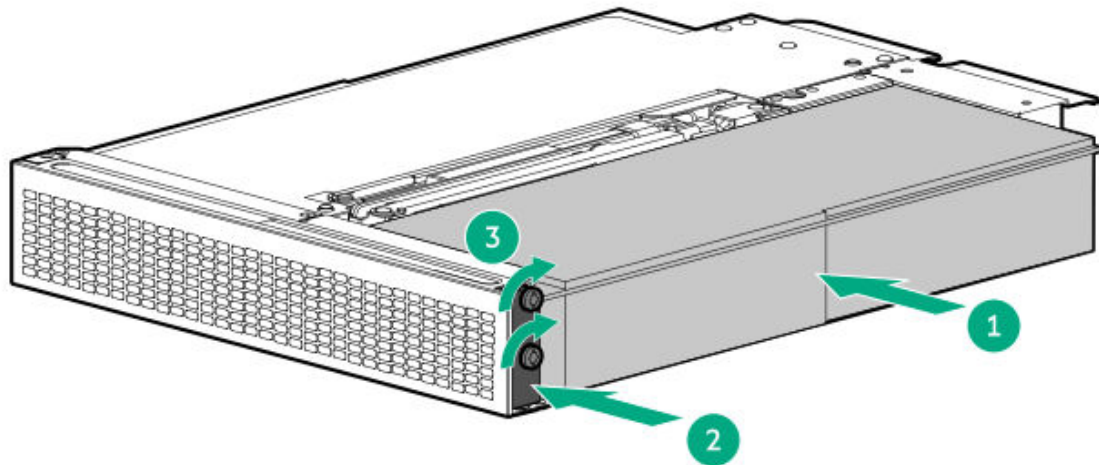

- .3. If installing the double-width accelerator, secure the accelerator on the GPU riser cage.

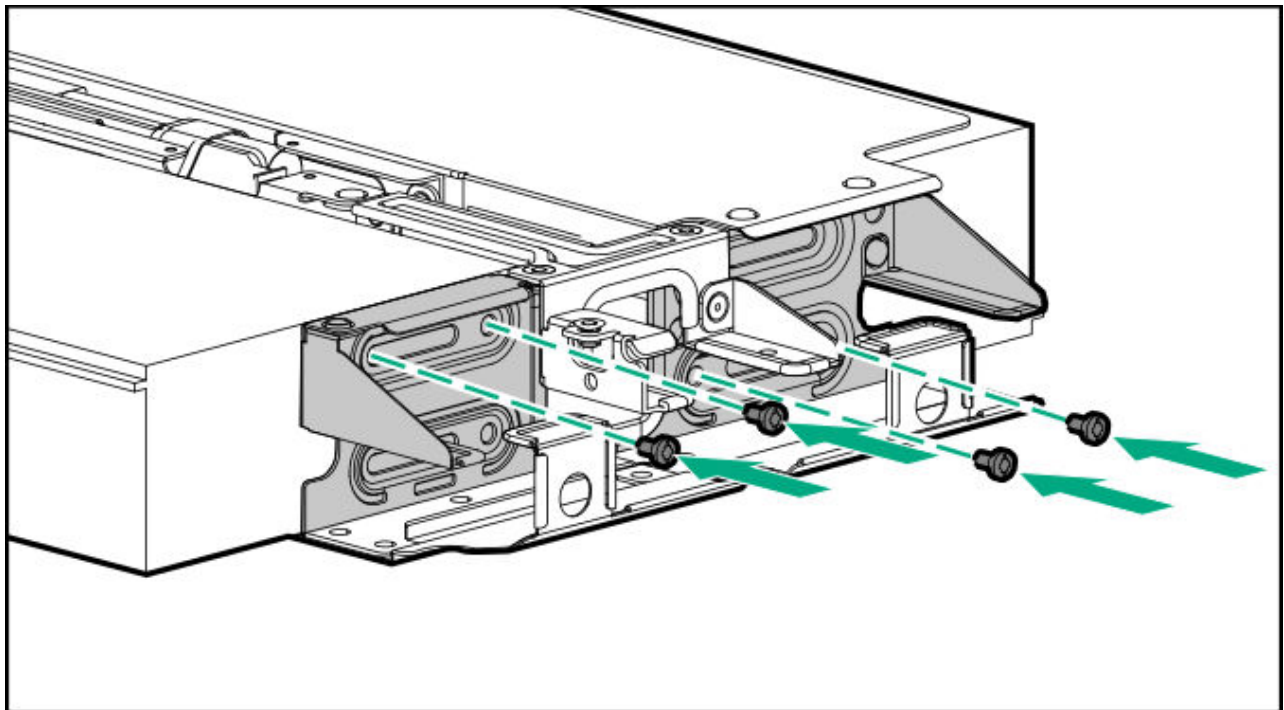

- .4. Route the accelerator auxiliary power cables and the GPU riser cables in the cable divider.

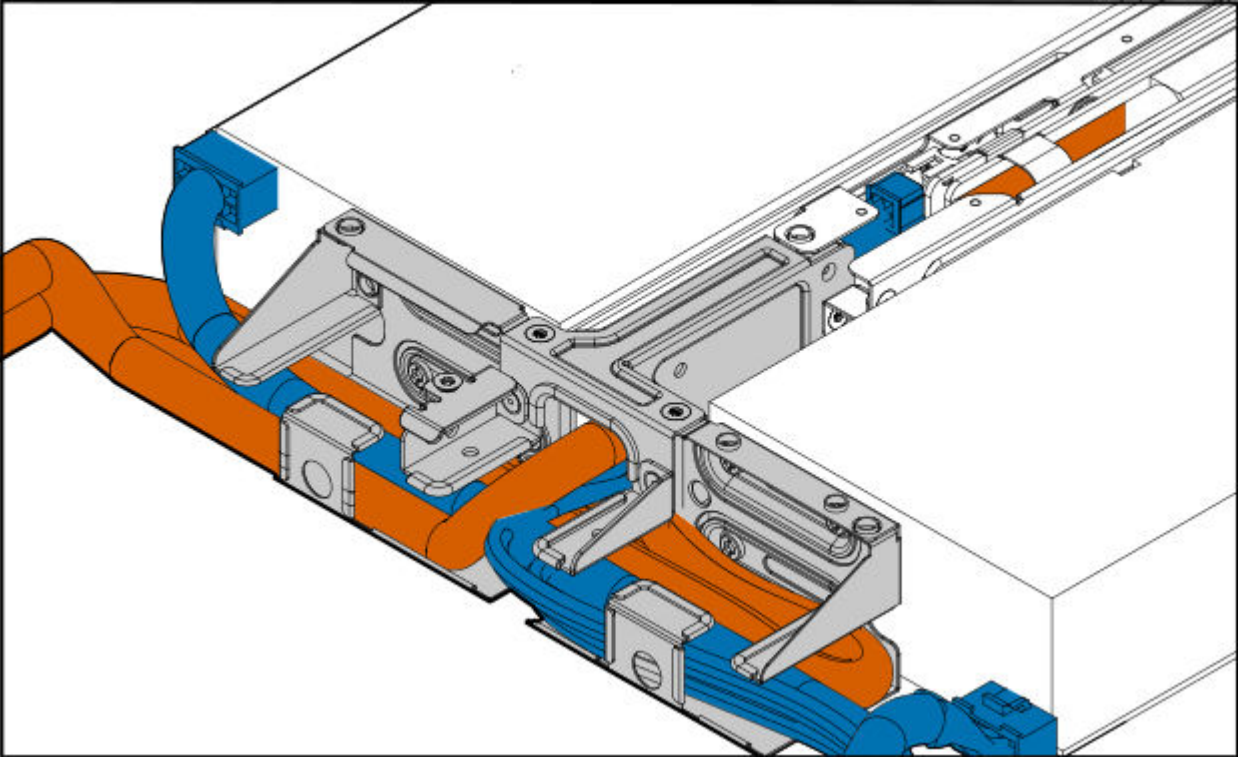

- .5. Install the GPU riser cage.
- .6. Install the middle cover.
- .7. Install the access panel.
- .8. Install the server into the rack.
- .9. Connect all peripheral cables to the server.
- !0. Connect the power cords:
 - a. Connect each power cord to the server.
 - b. Connect each power cord to the power source.
- !1. If installed, close the cable management arm.

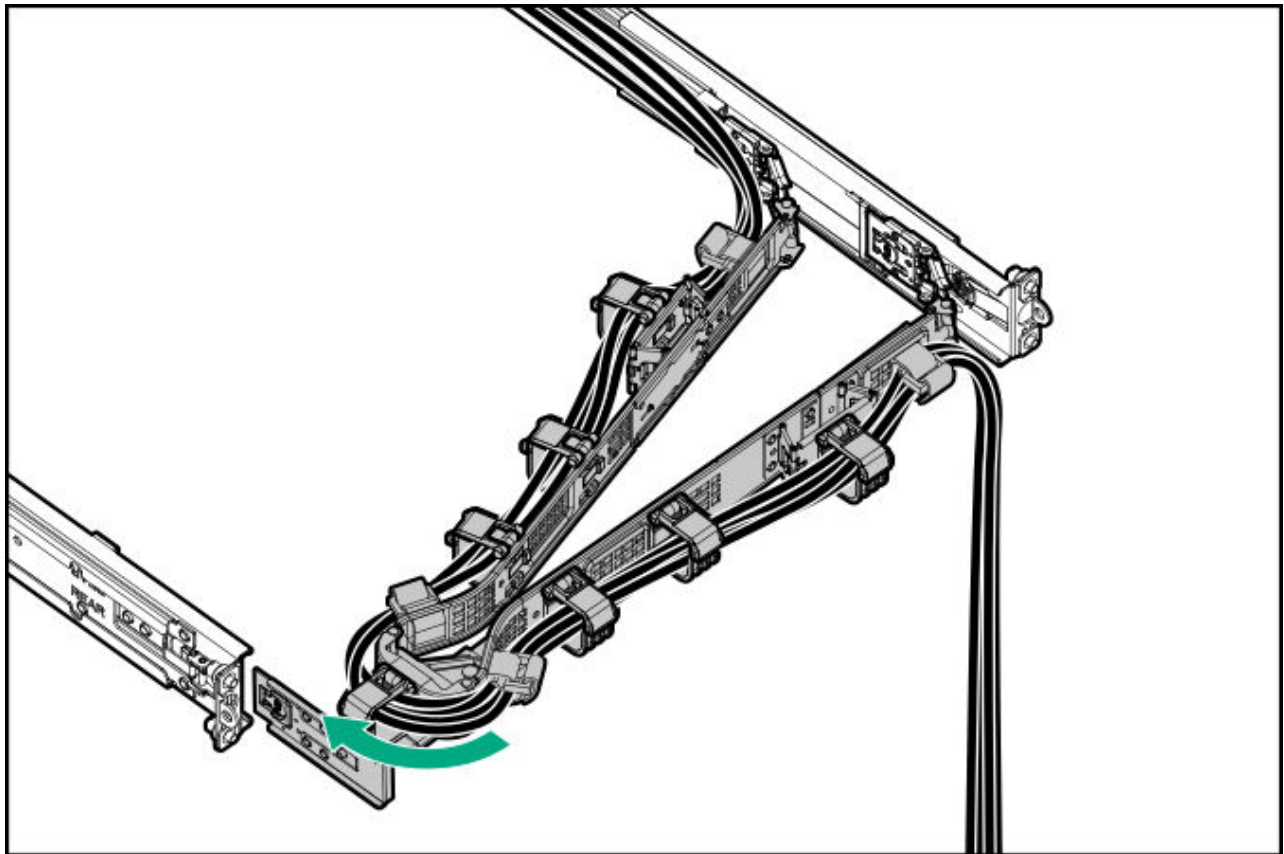

2. Power up the server.

Results

The installation procedure is complete.

Installing an accelerator in the rear riser cage

Prerequisites

Before installing this option, do the following:

- Be sure that the power supplies support the installation of this option. For more information, see the **[Hewlett Packard Enterprise Configurator website](#)**.
- Before you perform this procedure, make sure that you have a T-15 Torx screwdriver available.

About this task

The accelerator can be installed in the primary or secondary riser cage.



WARNING

To reduce the risk of personal injury from hot surfaces, allow the drives and the internal system components to cool before touching them.



CAUTION

To prevent damage to electrical components, properly ground the server before beginning any installation procedure. Improper grounding can cause electrostatic discharge.

Procedure

1. Back up all server data.
2. Power down the server.
3. If installed, open the cable management arm.
4. Remove all power:
 - a. Disconnect each power cord from the power source.
 - b. Disconnect each power cord from the server.
5. Disconnect all peripheral cables from the server.
6. Remove the server from the rack.
7. Place the server on a flat, level work surface.
8. Remove the access panel.
9. Remove the riser cage.
- .0. Remove the existing rear guide bracket from the card, if installed.
- .1. Install the card in the riser cage.

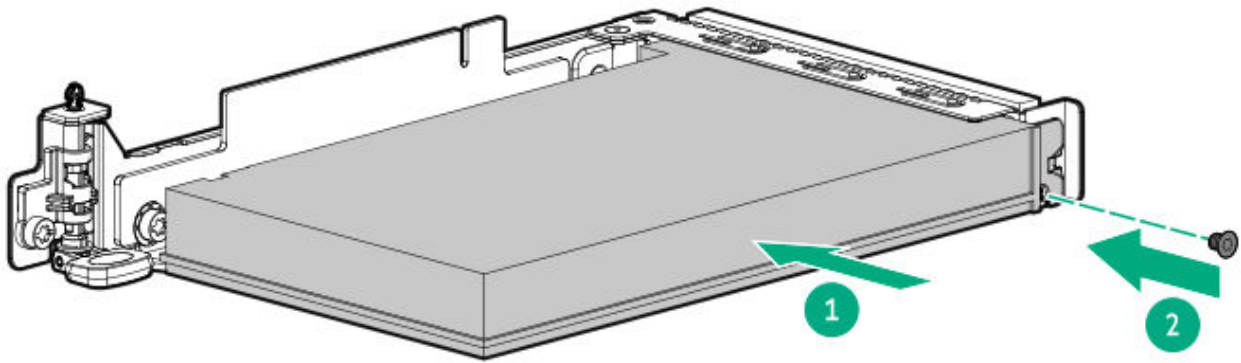

- .2. Install the riser cage.
- .3. Install the access panel.
- .4. Install the server into the rack.
- .5. Connect all peripheral cables to the server.
- .6. Connect the power cords:
 - a. Connect each power cord to the server.
 - b. Connect each power cord to the power source.
- .7. If installed, close the cable management arm.

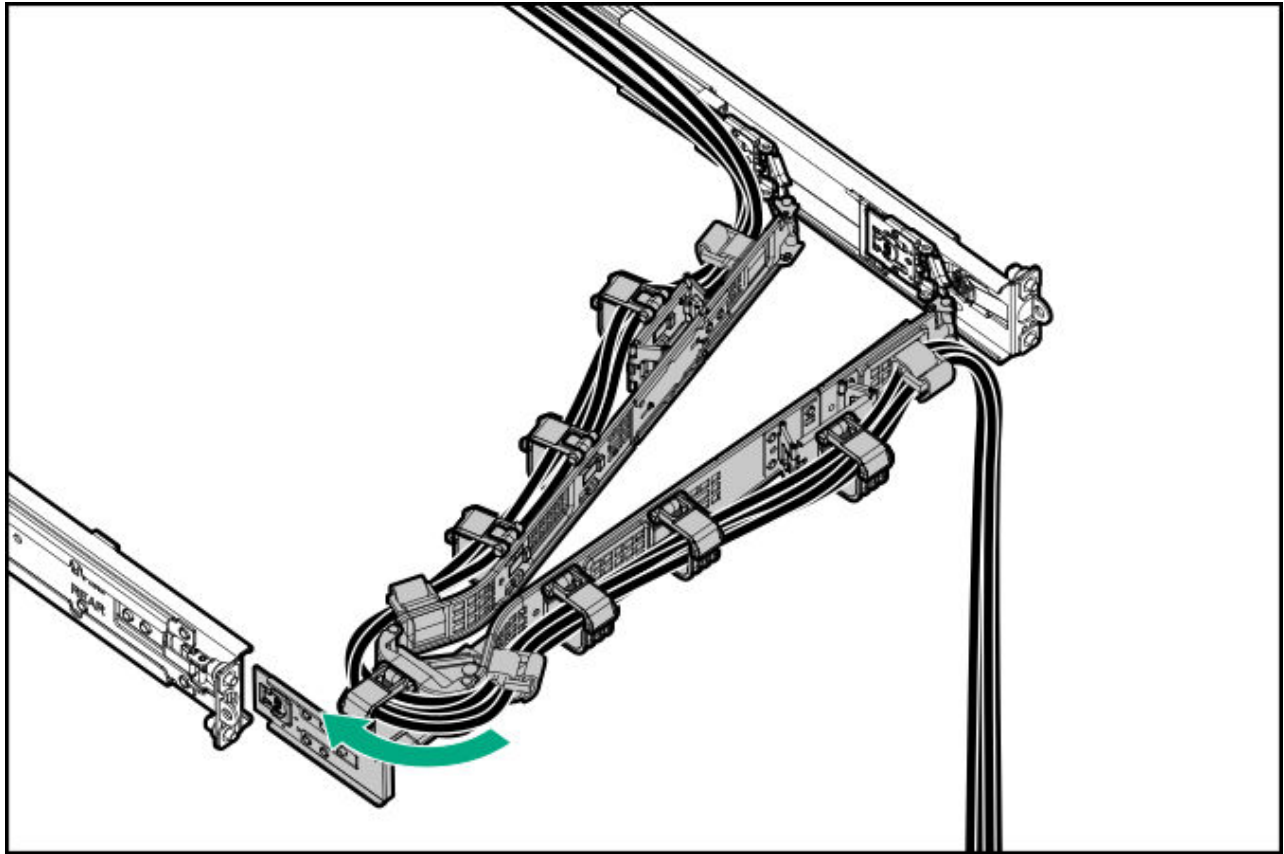

.8. Power up the server.

Results

The installation procedure is complete.

Energy pack option

Hewlett Packard Enterprise offers the HPE Smart Storage Battery as a centralized backup power source option to back up write cache content on the controllers in an unplanned server power outage.

After it is installed, the status of the energy pack appears in HPE iLO. For more information, see the iLO user guide on the Hewlett Packard Enterprise website (<https://www.hpe.com/support/hpeilodocs-quicklinks>).

Subtopics

HPE Smart Storage Hybrid Capacitor
Installing an energy pack

HPE Smart Storage Hybrid Capacitor

The capacitor pack can support up to three devices.

This server supports the 12 W or 16 W HPE Smart Storage Hybrid Capacitor with the 145 mm cable.

Before installing the HPE Smart Storage Hybrid Capacitor, verify that the system BIOS meets the minimum firmware requirements to support the capacitor pack.



IMPORTANT

If the system BIOS or controller firmware is older than the minimum recommended firmware versions, the capacitor pack will only support one device.

The capacitor pack is fully charged after the system boots.

For more information, see HPE Smart Storage Batteries and Hybrid Capacitors QuickSpecs:

https://www.hpe.com/psnow/doc/a00028553enw.pdf?jumpid=in_pdp-psnow-qs

Installing an energy pack

Procedure

1. Power down the server.
2. If installed, open the cable management arm.
3. Remove all power:
 - a. Disconnect each power cord from the power source.
 - b. Disconnect each power cord from the server.
4. Disconnect all peripheral cables from the server.
5. Remove the server from the rack.
6. Place the server on a flat, level work surface.
7. Remove the access panel.
8. Install the energy pack:
 - a. Attach one end of the energy pack on the chassis.
 - b. Press and hold the retention latch.

c. Pivot the energy pack downward and release the retention latch.

Make sure that the energy pack is locked in the retention latch.

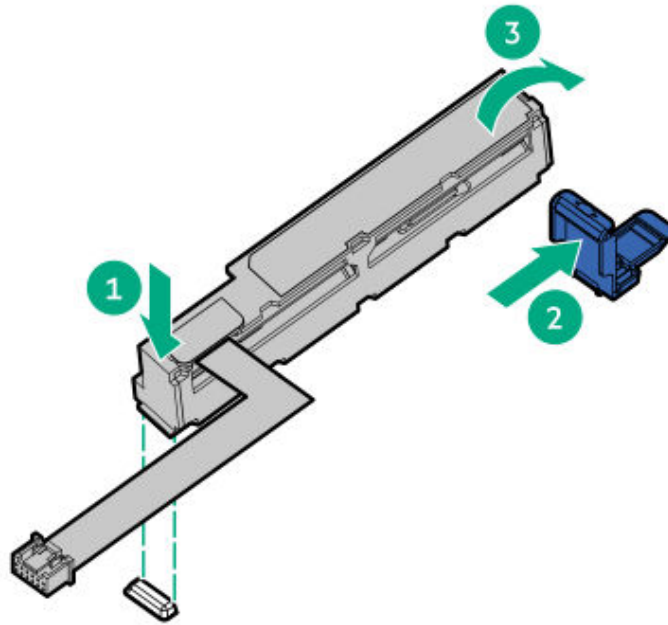

9. Cable the energy pack.

.0. Install the access panel.

.1. Install the server into the rack.

.2. Connect all peripheral cables to the server.

.3. Connect the power cords:

a. Connect each power cord to the server.

b. Connect each power cord to the power source.

.4. If installed, close the cable management arm.

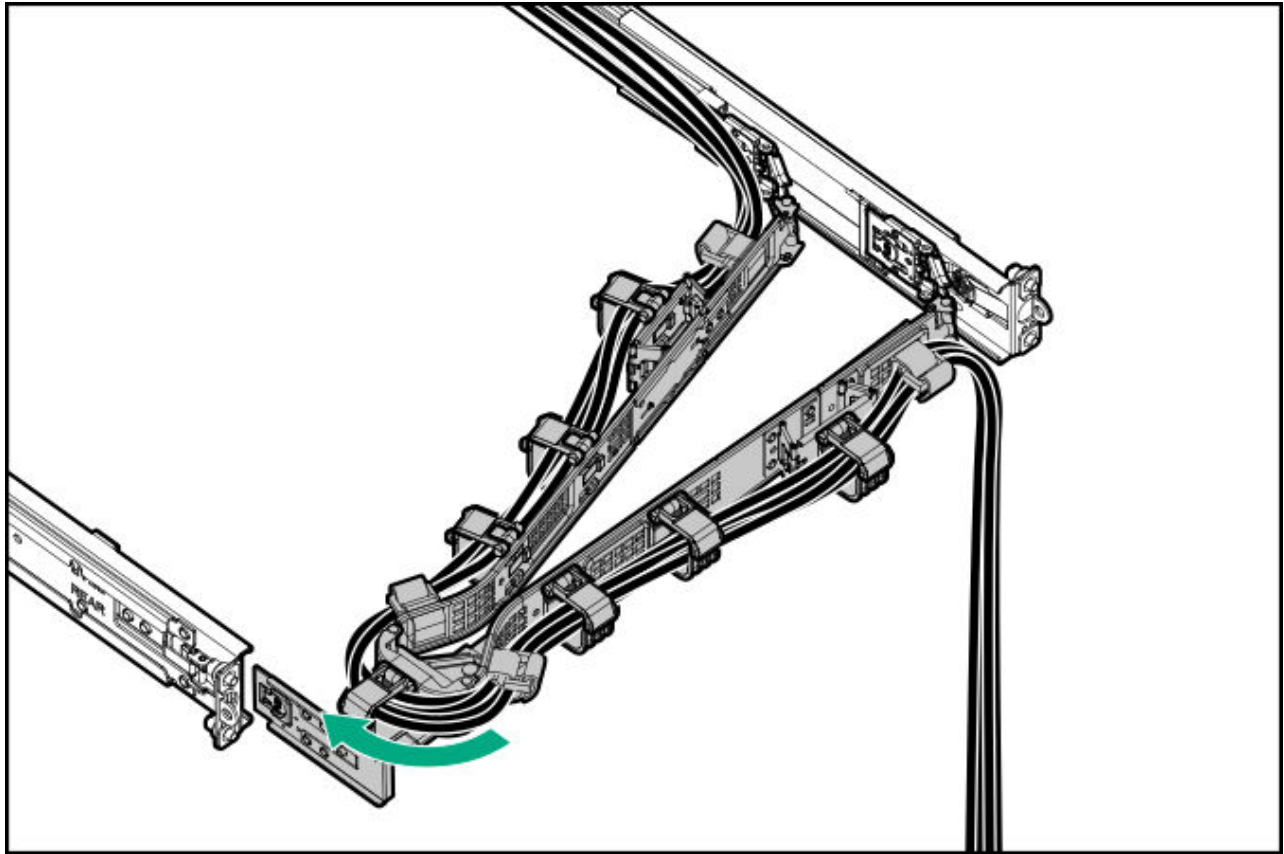

Results

The installation procedure is complete.

Memory options



IMPORTANT

This server does not support mixing LRDIMMs and RDIMMs. Attempting to mix any combination of these DIMMs can cause the server to halt during BIOS initialization. All memory installed in the server must be of the same type.

Subtopics

[DIMM population information](#)

[HPE SmartMemory speed information](#)

[Installing a DIMM](#)

DIMM population information

For specific DIMM population information, see the DIMM population guidelines on the Hewlett Packard Enterprise website (<https://www.hpe.com/docs/server-memory>).

HPE SmartMemory speed information

For more information about memory speed information in HPE servers using Intel processors, see the Hewlett Packard Enterprise website (<https://www.hpe.com/docs/memory-speed-table>).

Installing a DIMM

Prerequisites



CAUTION

- Do not install RDIMMs and LRDIMMs in the same server.
- Do not install ×4 and ×8 DRAM widths in the same server.

Attempting to mix any combination of these DIMMs can cause the server to halt during BIOS initialization. All memory installed in the server must be of the same type.



CAUTION

A discharge of static electricity from a finger or other conductor might damage system boards or other static-sensitive devices. To prevent damage, observe [antistatic precautions](#).

Procedure

1. [Power down the server](#).
2. If installed, [open the cable management arm](#).
3. Remove all power:
 - a. Disconnect each power cord from the power source.
 - b. Disconnect each power cord from the server.
4. Disconnect all peripheral cables from the server.

5. Remove the server from the rack.
6. Remove the access panel.
7. Install the DIMM:
 - a. Open the DIMM slot latches.
 - b. Align the notch on the bottom edge of the DIMM with the keyed surface of the DIMM slot, and then fully press the DIMM into the slot until the latches snap back into place.

The DIMM slots are structured to ensure proper installation. If you try to insert a DIMM but it does not fit easily into the slot, you might have positioned it incorrectly. Reverse the orientation of the DIMM and insert it again.

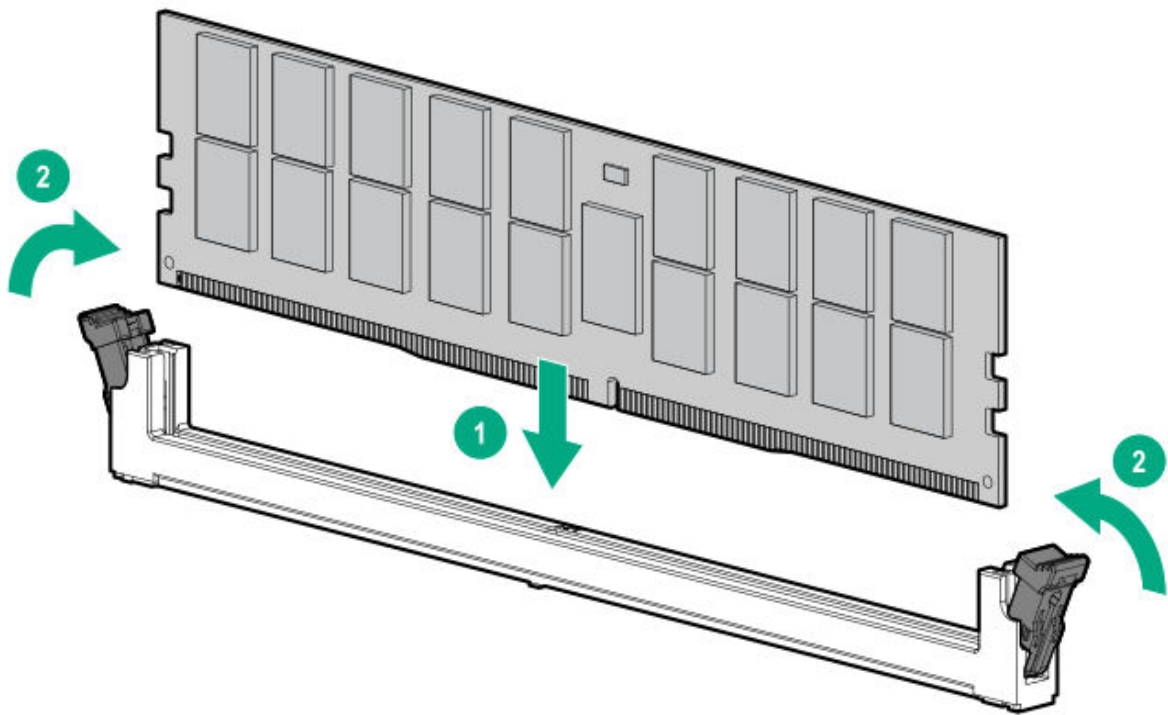

8. Install the access panel.
9. If installed, close the cable management arm.

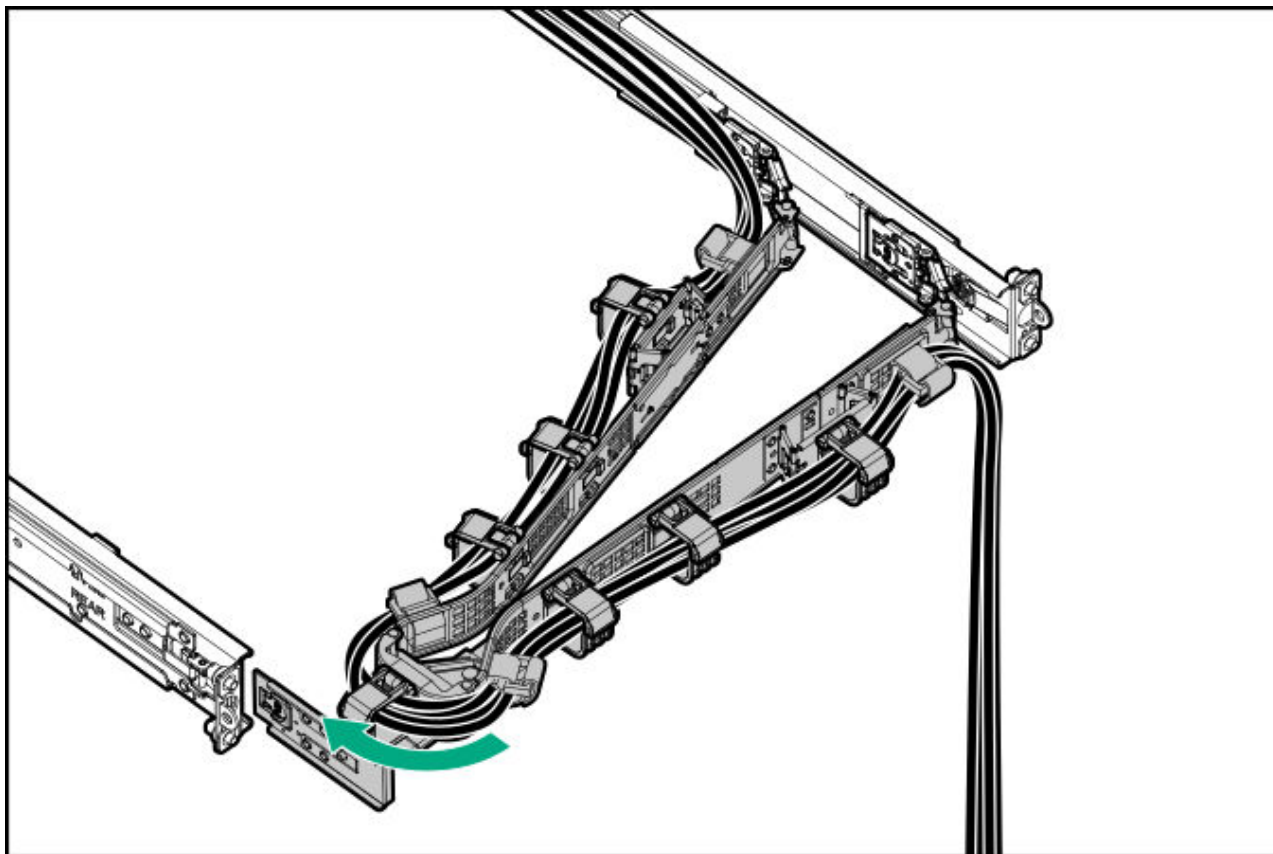

0. To configure the memory settings:

- a. From the boot screen, press **F9** to access UEFI System Utilities.
- b. From the System Utilities screen, select **System Utilities > System Configuration > BIOS/Platform Configuration (RBSU) > Memory Options**.

Results

The installation procedure is complete.

Storage controller options

The server supports the following storage controllers:

- Intel Virtual RAID on CPU (Intel VROC)—Provides enterprise-level hybrid RAID support for direct attached SATA and NVMe SSDs, including M.2 SSDs.
- HPE MR type-o and type-p Gen11 controllers
- HPE SR type-p Gen11 controllers

For more information on drive array and storage controller configuration, see [Configuring storage controllers](#).

When a tri-mode storage controller option is used together with a U.3 drive backplane, the system will support mixed drive configuration.

Subtopics

[Preparing the server for storage controller installation](#)

[Installing a type-p controller](#)

[Installing a type-o storage controller](#)

Preparing the server for storage controller installation

Prerequisites

Before beginning this procedure, download the Service Pack for ProLiant (SPP) from the Hewlett Packard Enterprise website (<https://www.hpe.com/servers/spp/download>).

Procedure

1. If the server was previously configured:
 - a. [Back up data on the system](#).
 - b. Close all applications.
 - c. Ensure that users are logged off and that all tasks are completed on the server.



CAUTION

In systems that use external data storage, be sure that the server is the first unit to be powered down and the last to be powered back up. Taking this precaution ensures that the system does not erroneously mark the drives as failed when the server is powered up.

2. If the server firmware is not the latest revision, [update the firmware](#).
3. If the new controller is the new boot device, [install the controller drivers](#).

Installing a type-p controller

Prerequisites

Before you perform this procedure, make sure that you have the following items available:

- T-10 Torx screwdriver

About this task



CAUTION

A discharge of static electricity from a finger or other conductor might damage system boards or other static-sensitive devices. To prevent damage, observe [antistatic precautions](#).



CAUTION

To prevent improper cooling and thermal damage, do not operate the server unless all PCIe slots have either a riser slot blank or an expansion card installed.

Procedure

1. [Power down the server](#).
2. If installed, [open the cable management arm](#).
3. Remove all power:
 - a. Disconnect each power cord from the power source.
 - b. Disconnect each power cord from the server.
4. Disconnect all peripheral cables from the server.
5. [Remove the server from the rack](#).
6. Place the server on a flat, level work surface.
7. [Remove the access panel](#).
8. [Remove the riser cage](#).
9. Remove the riser slot blank.

Retain the screw and blank for future use.

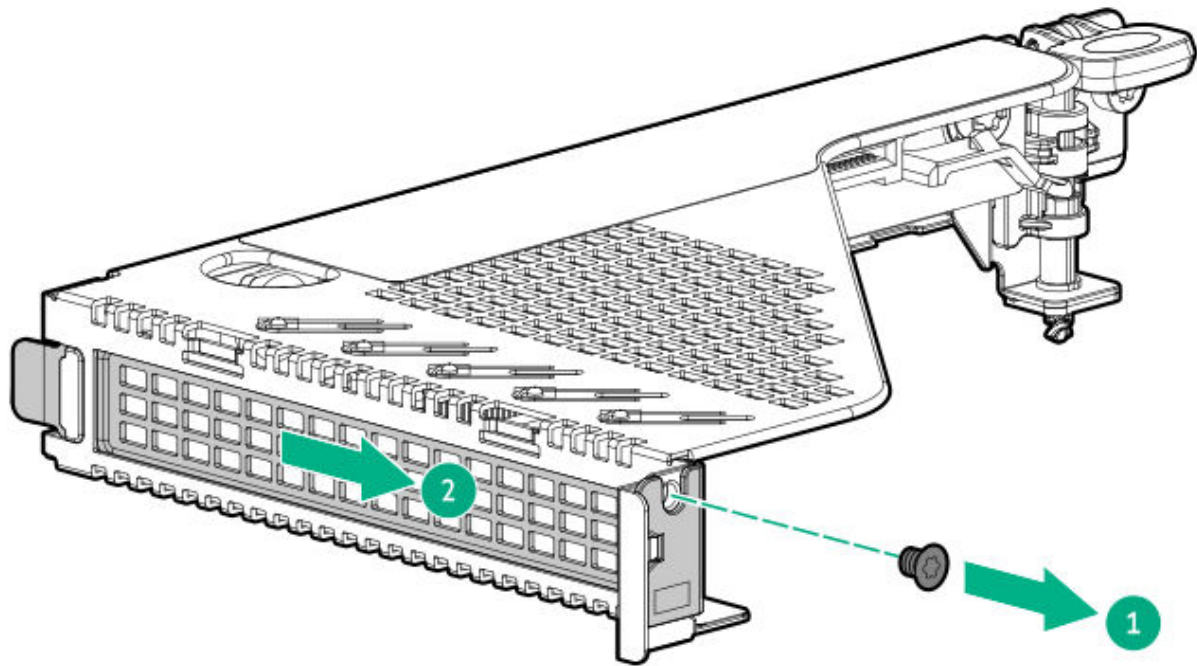

.0. Install the type-p storage controller.

Make sure that the controller is seated firmly in the slot.

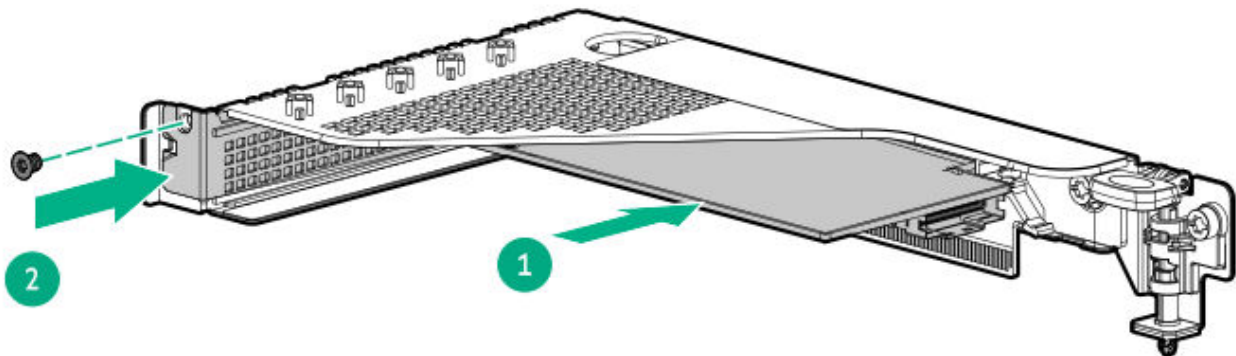

.1. Cable the type-p storage controller.

.2. Install the riser cage.

.3. Install the access panel.

.4. Install the server into the rack.

.5. Connect all peripheral cables to the server.

- .6. Connect the power cords:
 - a. Connect each power cord to the server.
 - b. Connect each power cord to the power source.
- .7. If installed, close the cable management arm.

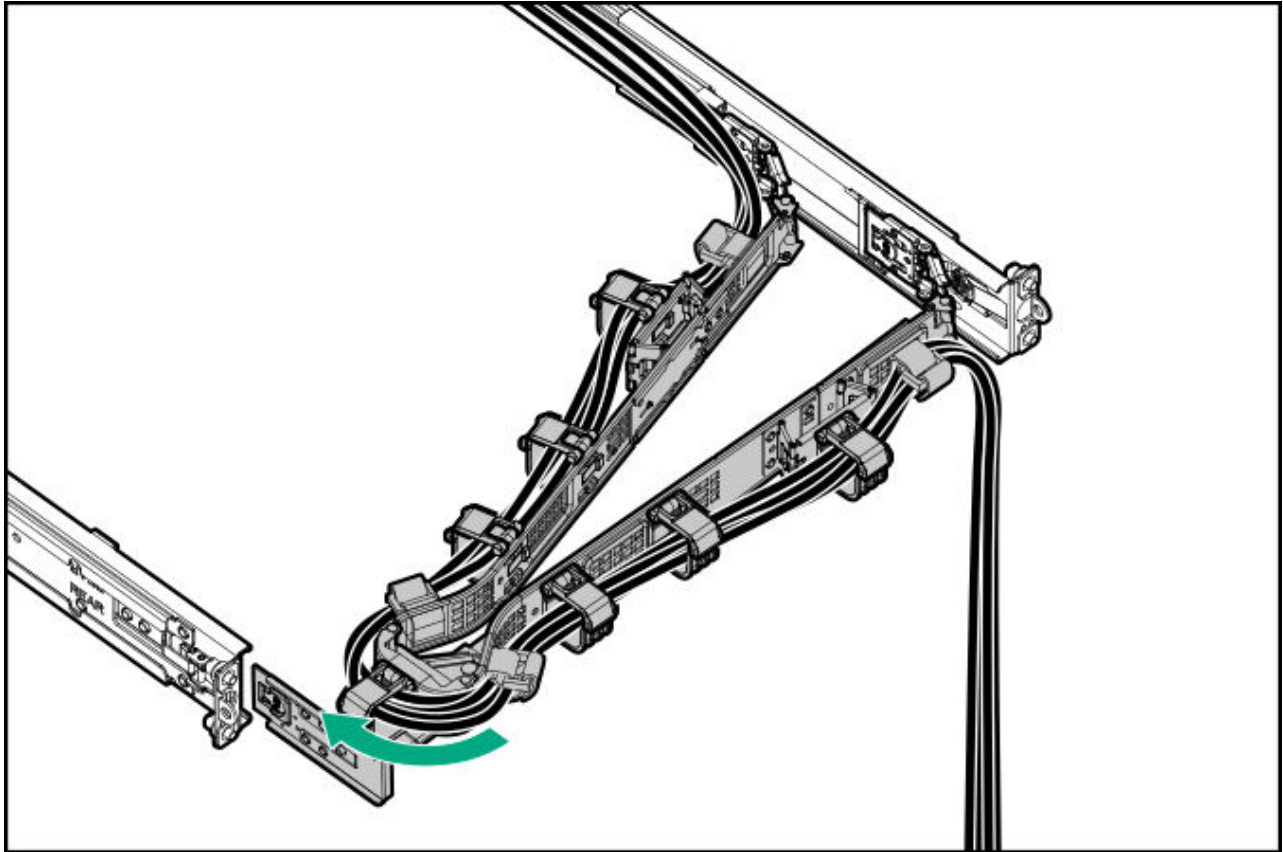

- .8. Power up the server.

Results

The installation procedure is complete.

Installing a type-o storage controller

Prerequisites

The flash-backed write cache (FBWC) feature of some storage controllers requires the installation of an energy pack option. For more information, see the controller QuickSpecs on the Hewlett Packard Enterprise website (<https://www.hpe.com/info/quickspecs>).

Before you perform this procedure, make sure that you have the following items available:

- Compatible controller cable option
- T-10 Torx screwdriver

About this task



CAUTION

A discharge of static electricity from a finger or other conductor might damage system boards or other static-sensitive devices. To prevent damage, observe antistatic precautions.

Procedure

1. Power down the server.
2. If installed, open the cable management arm.
3. Remove all power:
 - a. Disconnect each power cord from the power source.
 - b. Disconnect each power cord from the server.
4. Disconnect all peripheral cables from the server.
5. Remove the server from the rack.
6. Place the server on a flat, level work surface.
7. Remove the access panel.
8. Remove the secondary riser cage.
9. Remove the OCP slot blank:
 - a. Remove the blank screw.
 - b. Remove the blank.

Retain the screw and blank for future use.

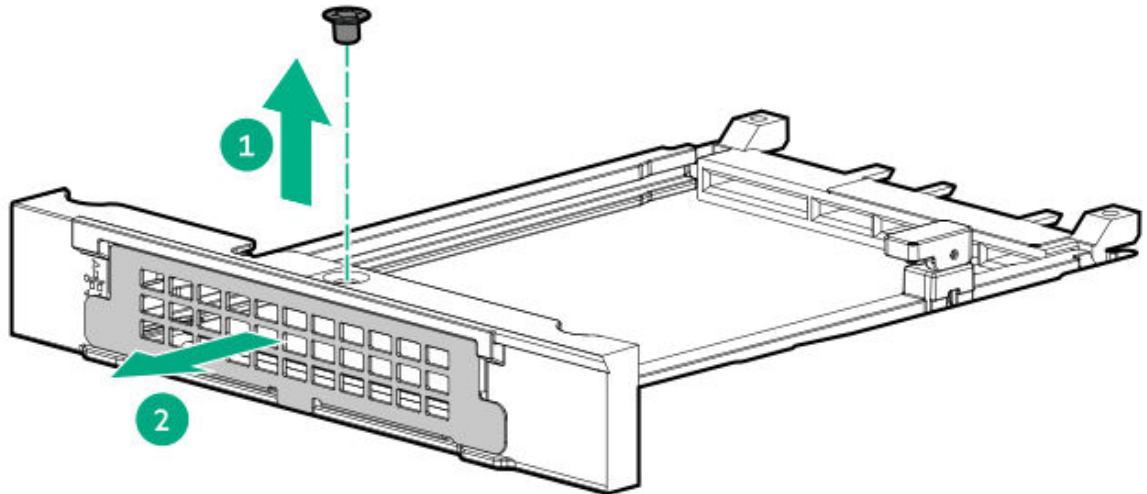

.0. Install the type-o storage controller:

- a. Rotate the locking pin to the open (vertical) position.
- b. Slide the controller into the bay until it clicks into place.
Make sure that the controller is seated firmly in the slot.
- c. Rotate the locking pin to the close (horizontal) position.

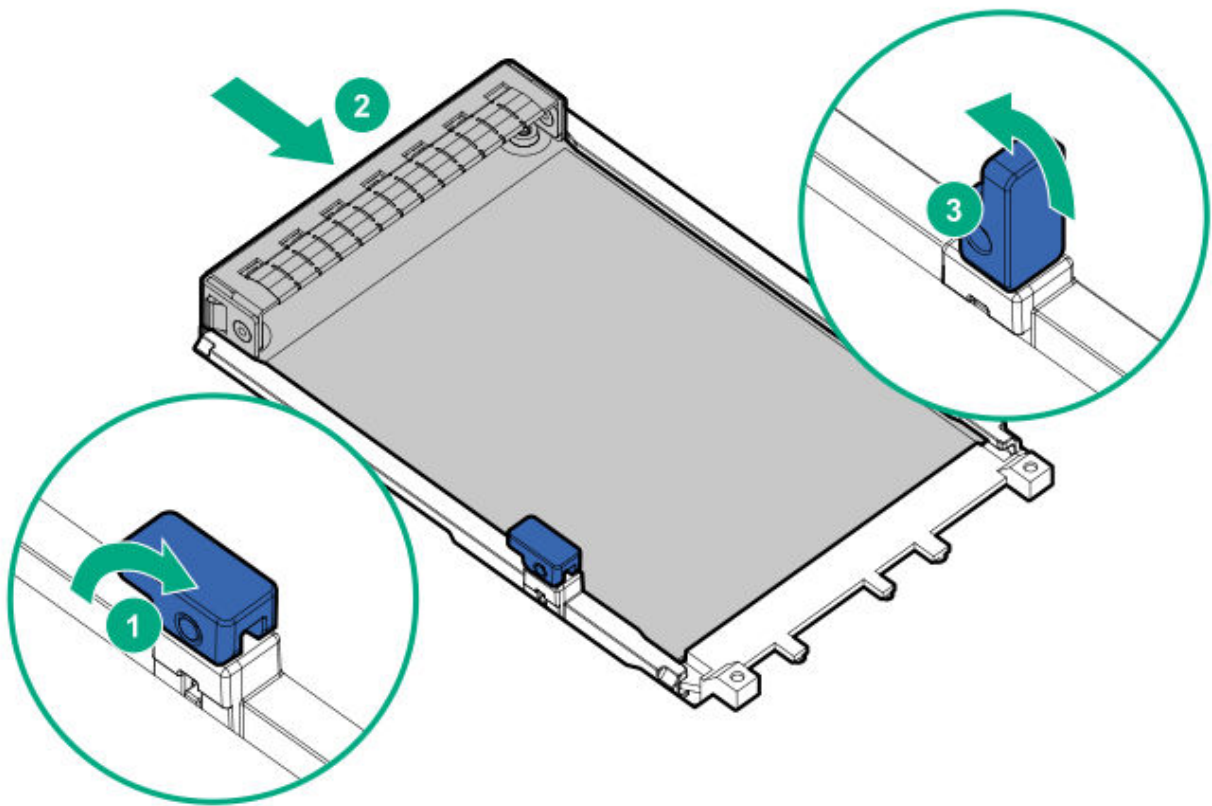

- .1. Cable the type-o storage controller.
- .2. Install the secondary riser cage.
- .3. Install the access panel.
- .4. Install the server into the rack.
- .5. Connect all peripheral cables to the server.
- .6. Connect the power cords:
 - a. Connect each power cord to the server.
 - b. Connect each power cord to the power source.
- .7. If installed, close the cable management arm.

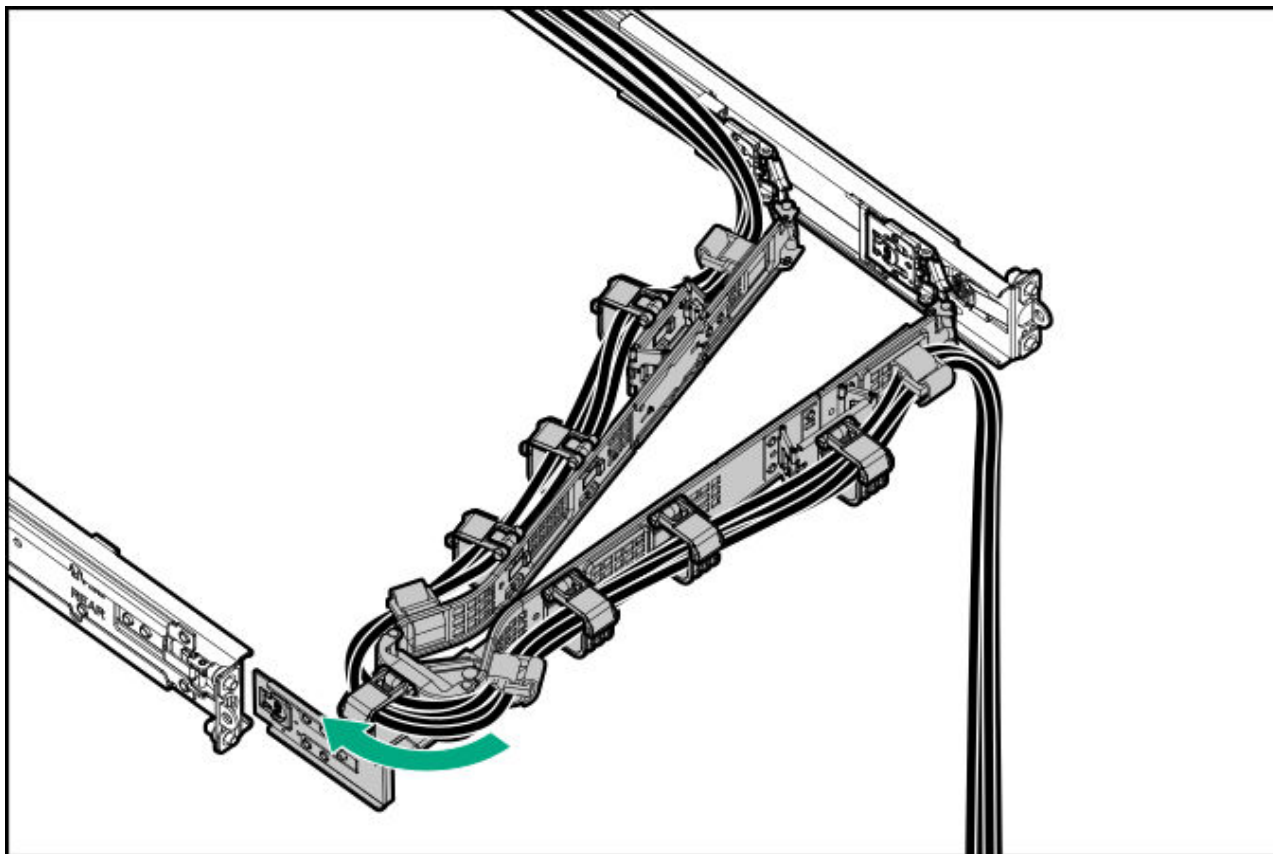

.8. Power up the server.

Results

The installation procedure is complete.

OCP NIC 3.0 option

The server supports SFF dual-port and quad-port OCP NIC 3.0 options with various interfaces and advanced interconnect features for high-bandwidth applications.

Subtopics

Installing the OCP NIC 3.0 adapter

Installing the OCP NIC 3.0 adapter

Prerequisites

Before you perform this procedure, make sure that you have a T-10 Torx screwdriver available.

About this task



CAUTION

A discharge of static electricity from a finger or other conductor might damage system boards or other static-sensitive devices. To prevent damage, observe antistatic precautions.



CAUTION

The port blank provides EMI shielding and helps maintain proper thermal status inside the server. Do not operate the server when a port blank is removed without the corresponding I/O port option installed.

Procedure

1. Power down the server.
2. If installed, open the cable management arm.
3. Remove all power:
 - a. Disconnect each power cord from the power source.
 - b. Disconnect each power cord from the server.
4. Disconnect all peripheral cables from the server.
5. Remove the server from the rack.
6. Place the server on a flat, level work surface.
7. Remove the access panel.
8. Remove the secondary riser cage.
9. Remove the OCP slot blank:
 - a. Remove the blank screw.
 - b. Remove the blank.

Retain the screw and blank for future use.

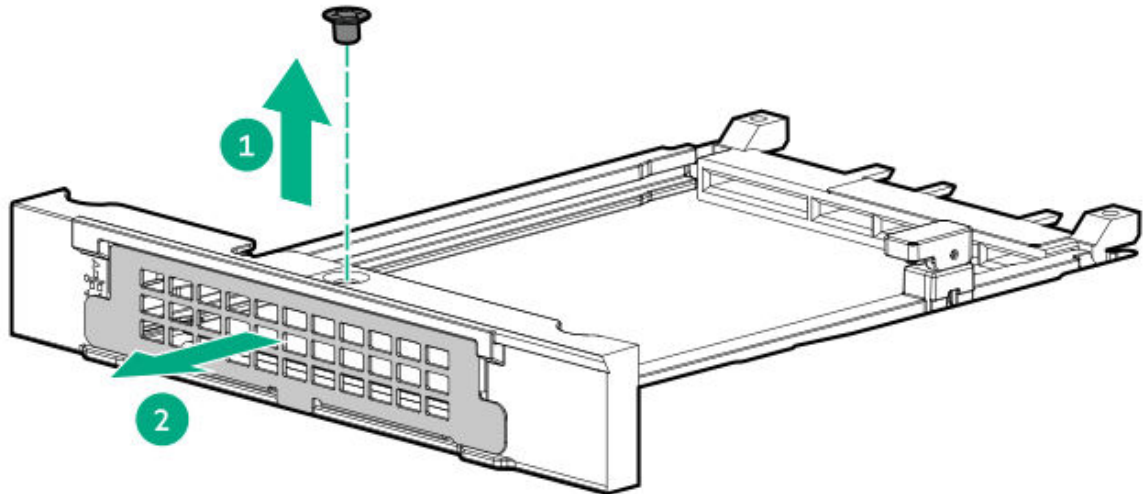

.0. Install the OCP NIC:

- a. Rotate the locking pin to the open (vertical) position.
- b. Slide the OCP NIC into the bay until it clicks into place.
Ensure that the OCP NIC is seated firmly in the slot.
- c. Rotate the locking pin to the close (horizontal) position.

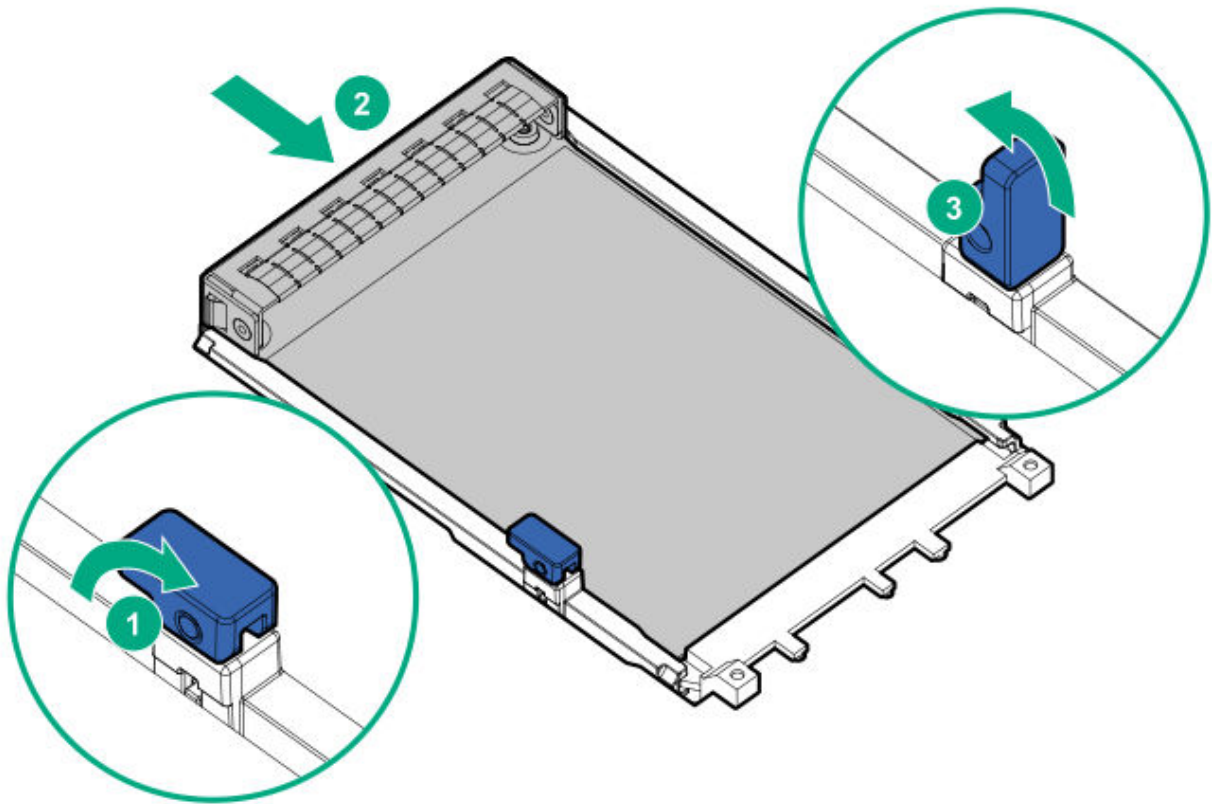

- .1. Install the secondary riser cage.
- .2. Install the access panel.
- .3. Install the server into the rack.
- .4. Connect all peripheral cables to the server.
- .5. Connect the power cords:
 - a. Connect each power cord to the server.
 - b. Connect each power cord to the power source.
- .6. If installed, close the cable management arm.

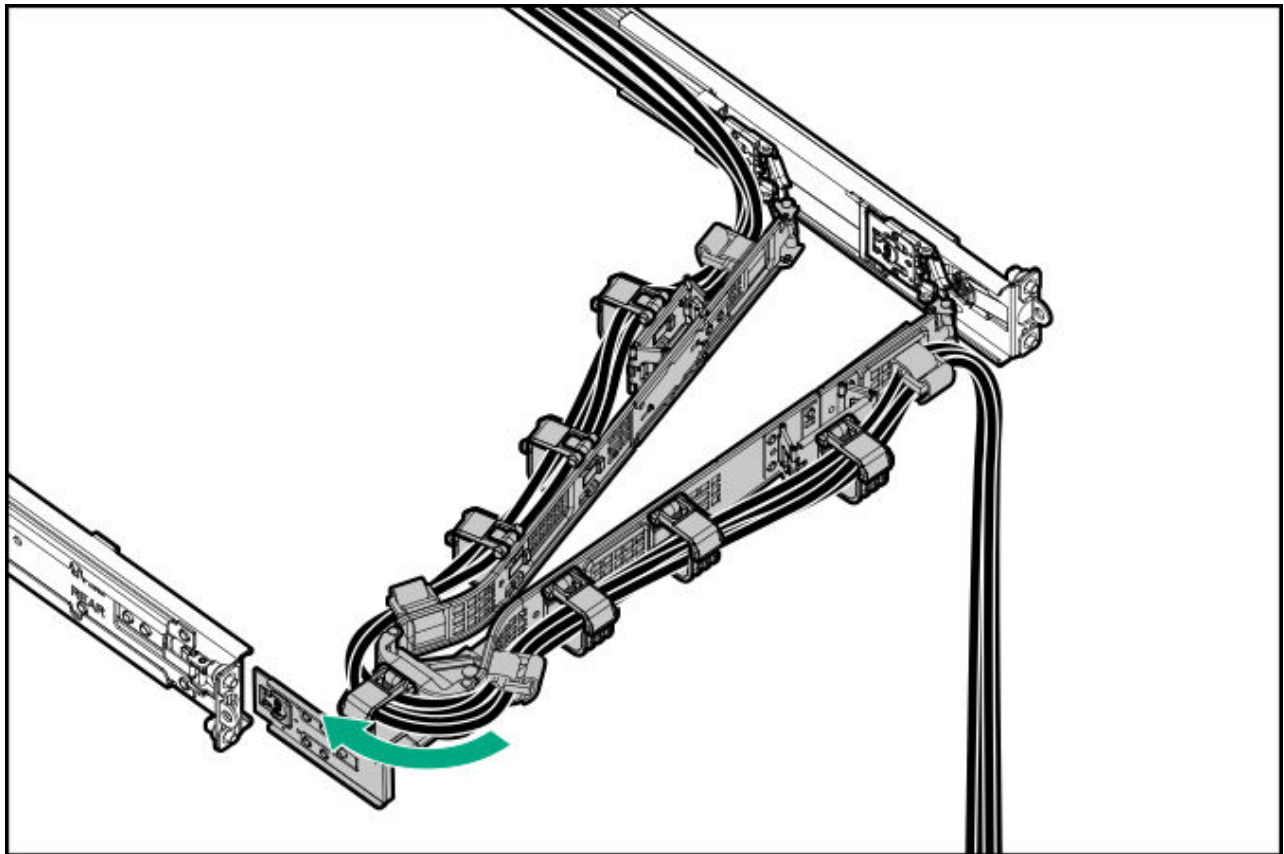

.7. Power up the server.

Results

The installation procedure is complete.

HPE NS204i-u Boot Device option

Note the following information about the HPE NS204i-u Boot Device option:

- The HPE NS204i-u NVMe Hot Plug Boot Optimized Storage Device is a PCIe5 custom form factor module that includes two hot-pluggable 2280 M.2 NVMe SSDs.
- This boot device enables the deployed OS to be mirrored through a dedicated hardware RAID 1.
- The boot device auto-creates a RAID1 volume during boot. This means the boot device does not require further RAID configuration.
- This boot device is compatible with the following native OS:
 - Windows

- Linux
- VMware
- This boot device uses native inbox OS NVMe drivers.

Subtopics

Installing the HPE NS204i-u Boot Device

Installing the HPE NS204i-u Boot Device

Prerequisites

Before beginning installation, make sure that the server is updated with the latest operating system firmware and drivers.

Before you perform this procedure, make sure that you have the following items available:

- T-15 Torx screwdriver
- Phillips No. 1 screwdriver

About this task



CAUTION

A discharge of static electricity from a finger or other conductor might damage system boards or other static-sensitive devices. To prevent damage, observe antistatic precautions.

Procedure

Installing drives onto the boot device

1. Remove the failed drive and replace it with a new drive:
 - a. Press and hold the carrier latch.
 - b. Pivot the latch to open.
 - c. Slide the carrier out from the boot device cage.

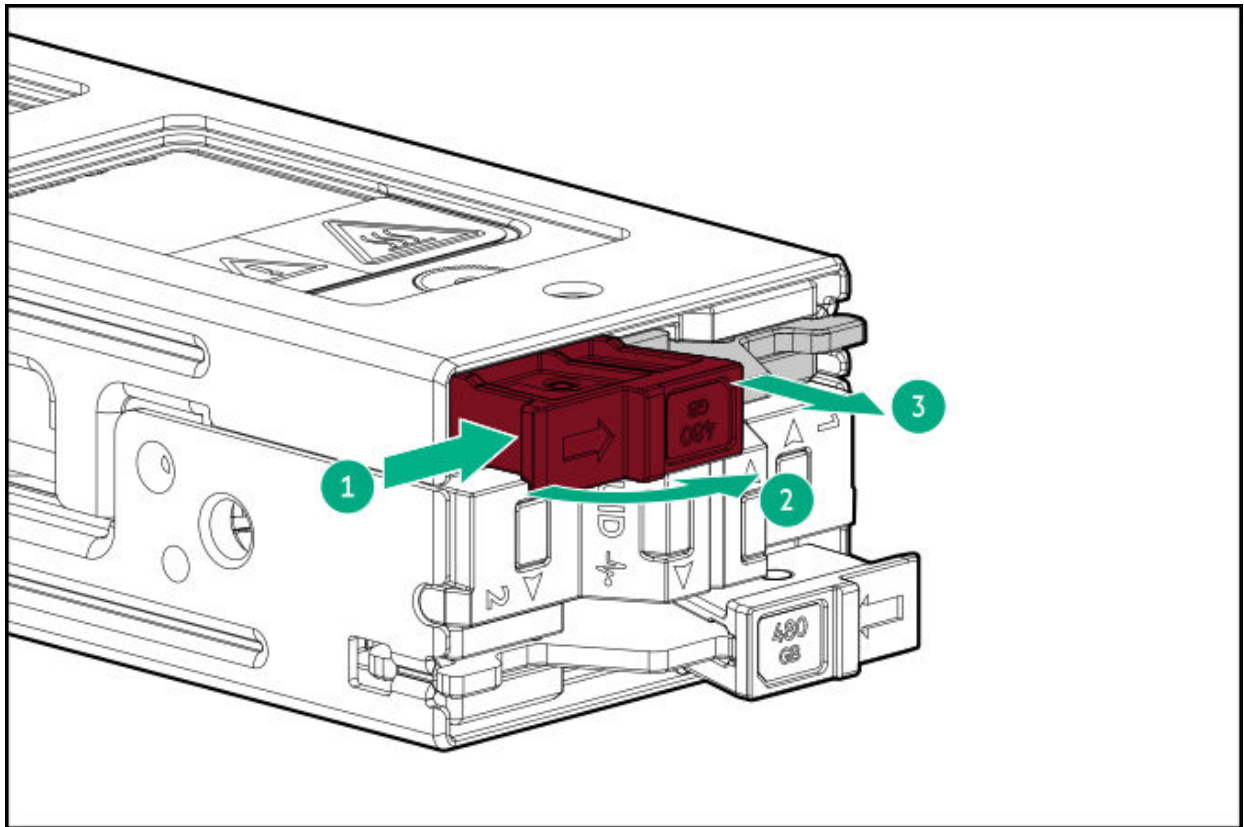

- d. Remove the SSD mounting screw.
- e. Tilt the SSD at a 45° angle, and then remove the failed SSD from the M.2 slot.

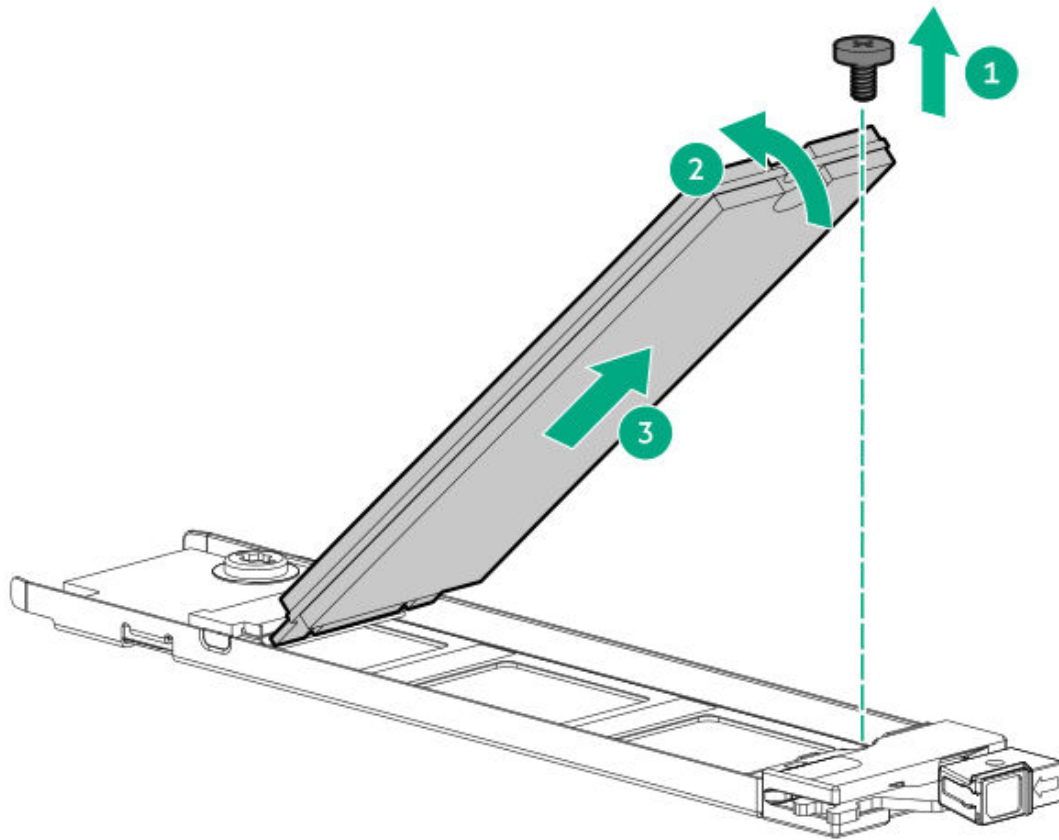

- f. Insert the new SSD into the M.2 slot at a 45° angle.
- g. Carefully press the SSD down to the horizontal position.
- h. Install the SSD mounting screw.

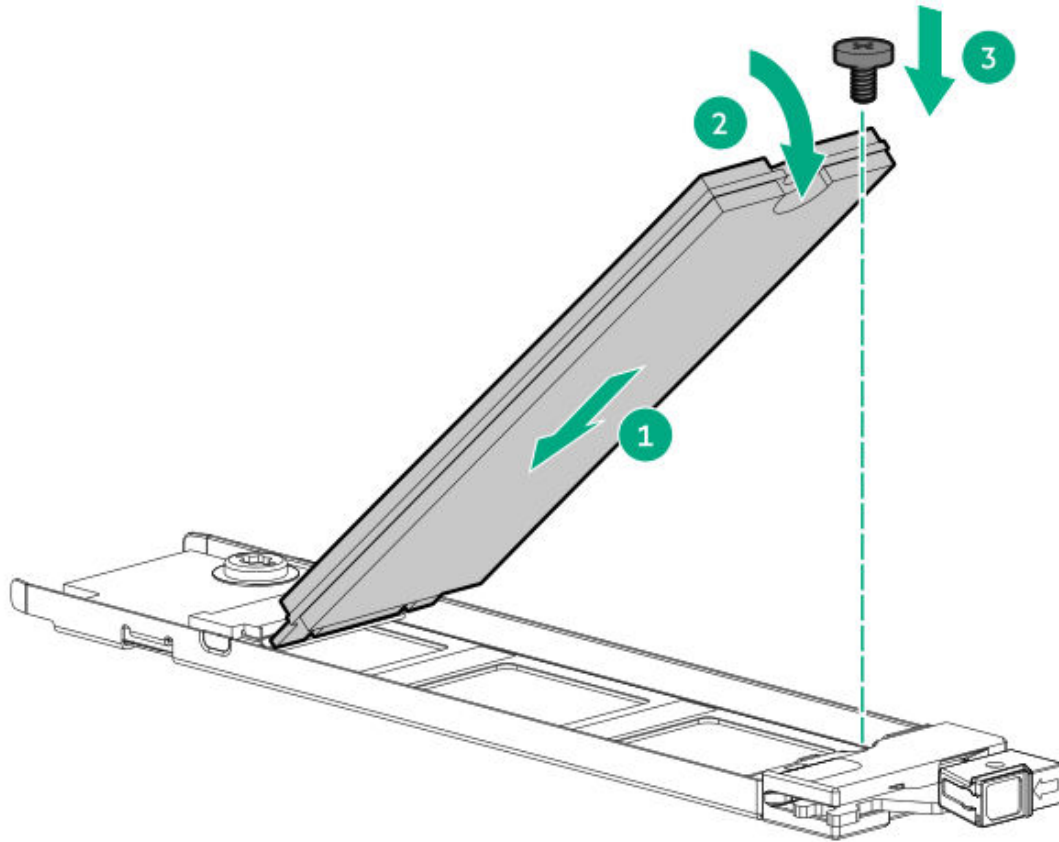

- i. If closed, pivot the carrier latch to open.
- j. Slide the carrier with the new SSD into the boot device cage.
- k. Pivot the latch to close.

Make sure that the carrier latch is locked on the boot device cage.

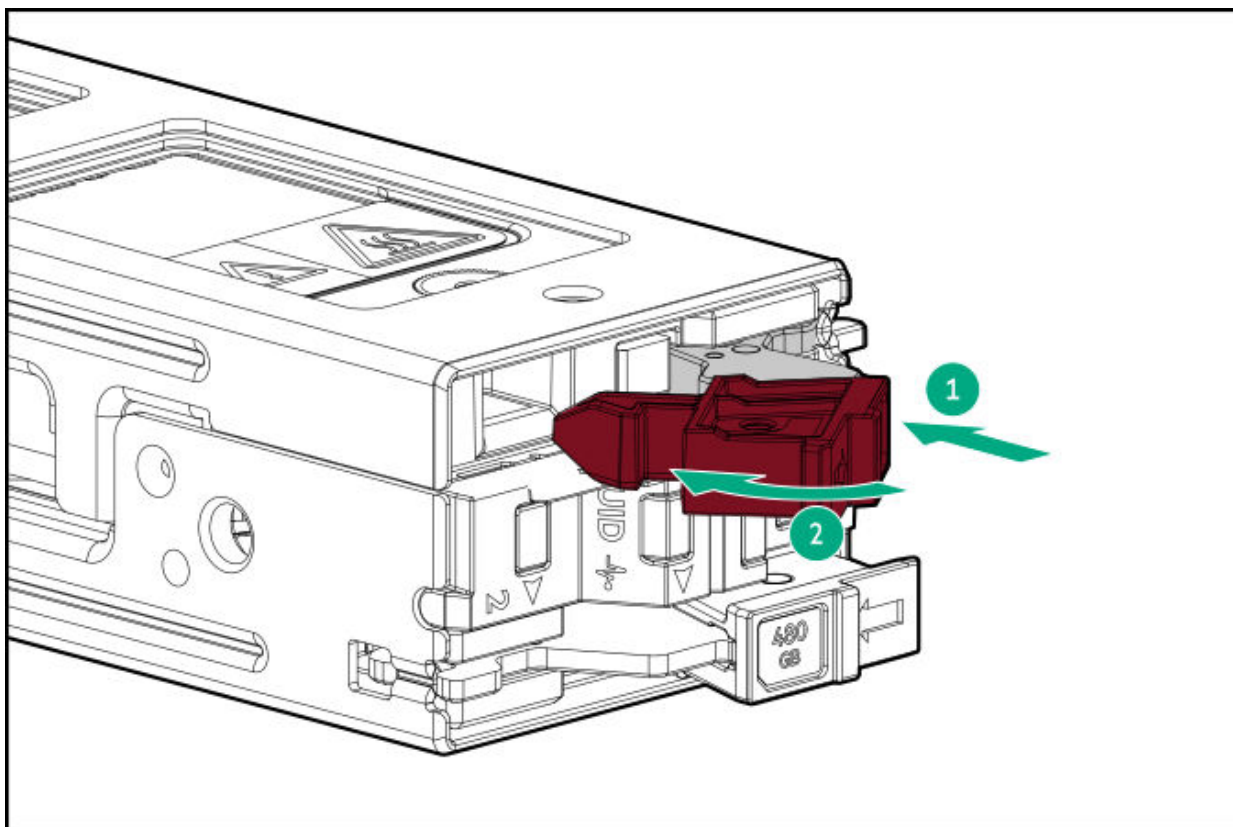

The boot device automatically rebuilds the RAID 1 volume.

2. Install the SSD on the boot device carrier:

- a. Remove the SSD mounting screw.

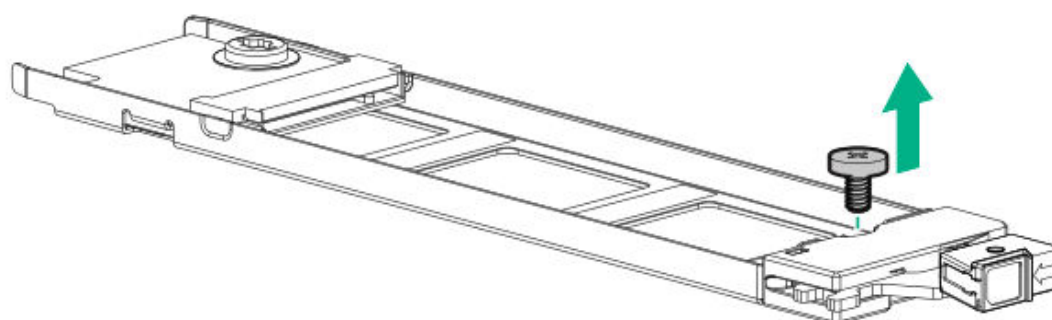

- b. Insert the SSD into the M.2 slot at a 45° angle.
- c. Carefully press the SSD down to the horizontal position.
- d. Install the SSD mounting screw.

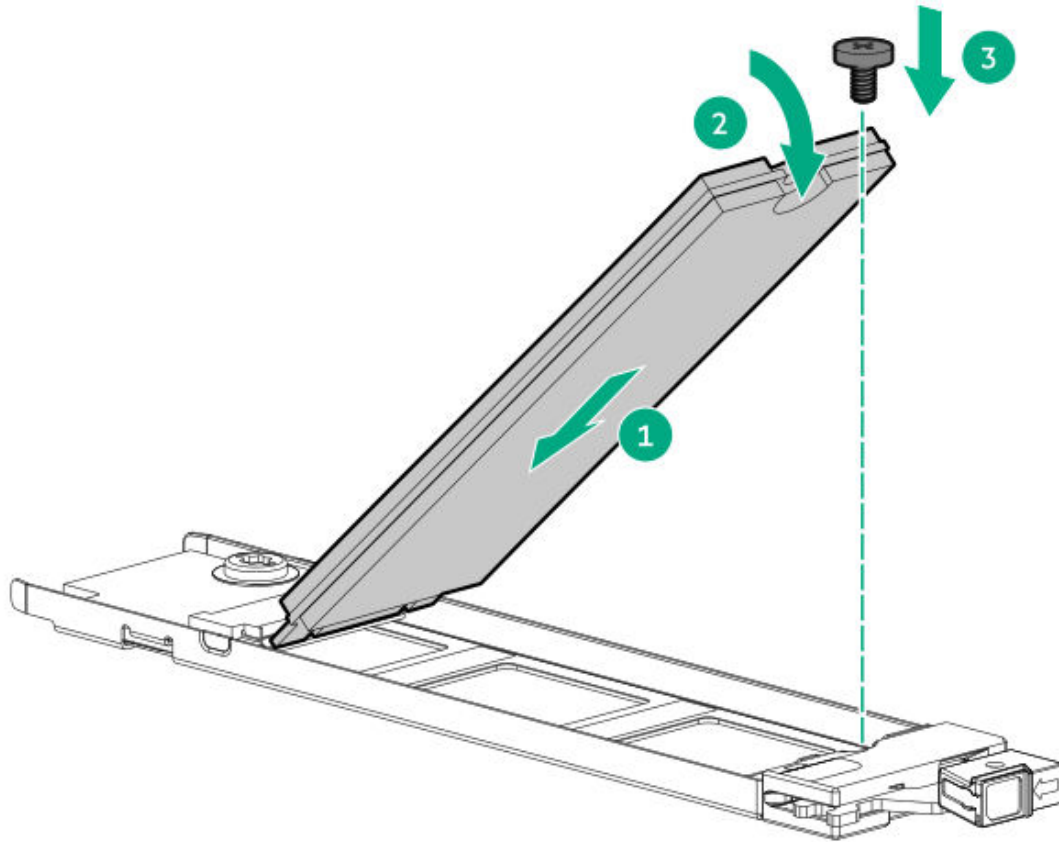

3. Install the boot device carriers:
 - a. If closed, pivot the carrier latch to open.
 - b. Slide the carrier into the boot device cage.
 - c. Pivot the latch to close.

Make sure that the carrier latch is locked on the boot device cage.

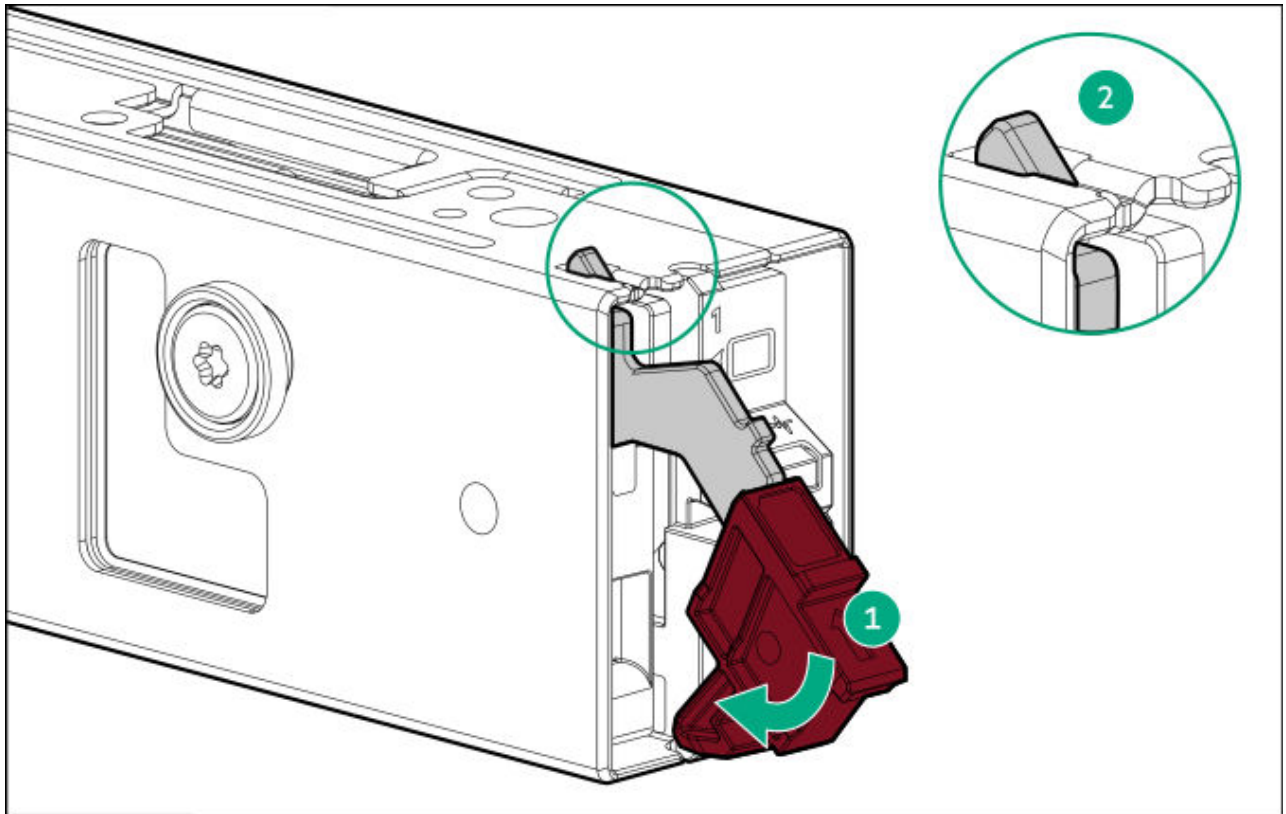

Installing the boot device

4. If installed, remove the front bezel.
5. Power down the server.
6. If installed, open the cable management arm.
7. Remove all power:
 - a. Disconnect each power cord from the power source.
 - b. Disconnect each power cord from the server.
8. Disconnect all peripheral cables from the server.
9. Remove the server from the rack.
- .0. Place the server on a flat, level work surface.
- .1. Remove the access panel.
- .2. Remove the secondary riser cage.
- .3. Remove the security cover to allow hot-plug access to the SSDs.

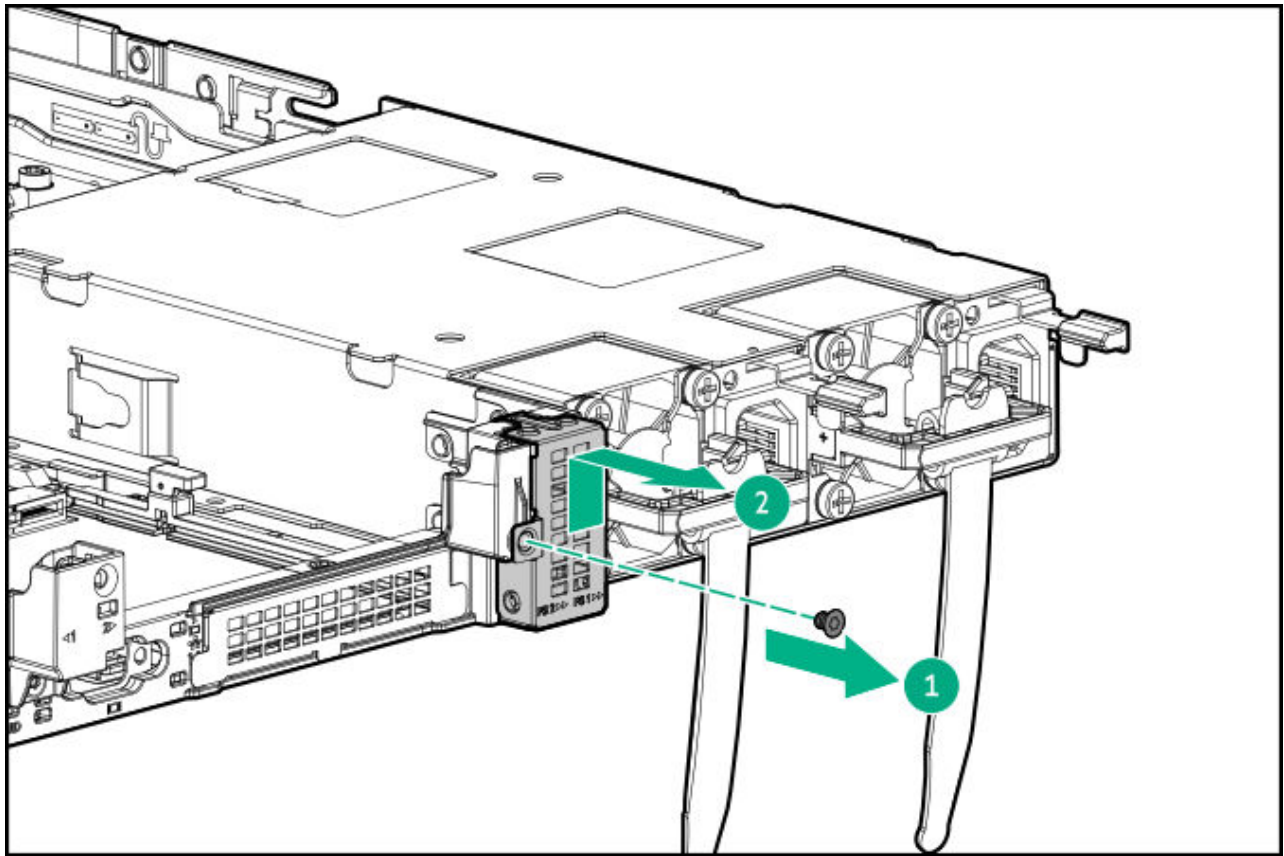

- .4. Install the latch onto the boot device.
 - a. Slide the latch onto the boot device.
 - b. Install the screw.

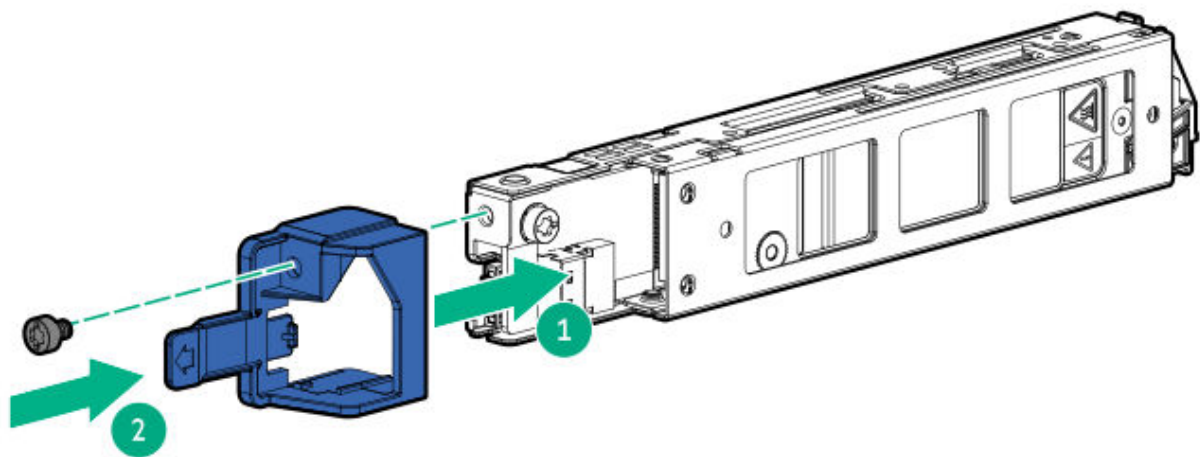

- .5. Install the boot device:

- a. Slide the boot device assembly into the latches.
- b. Push the boot device assembly to the left and against the power supply cage.

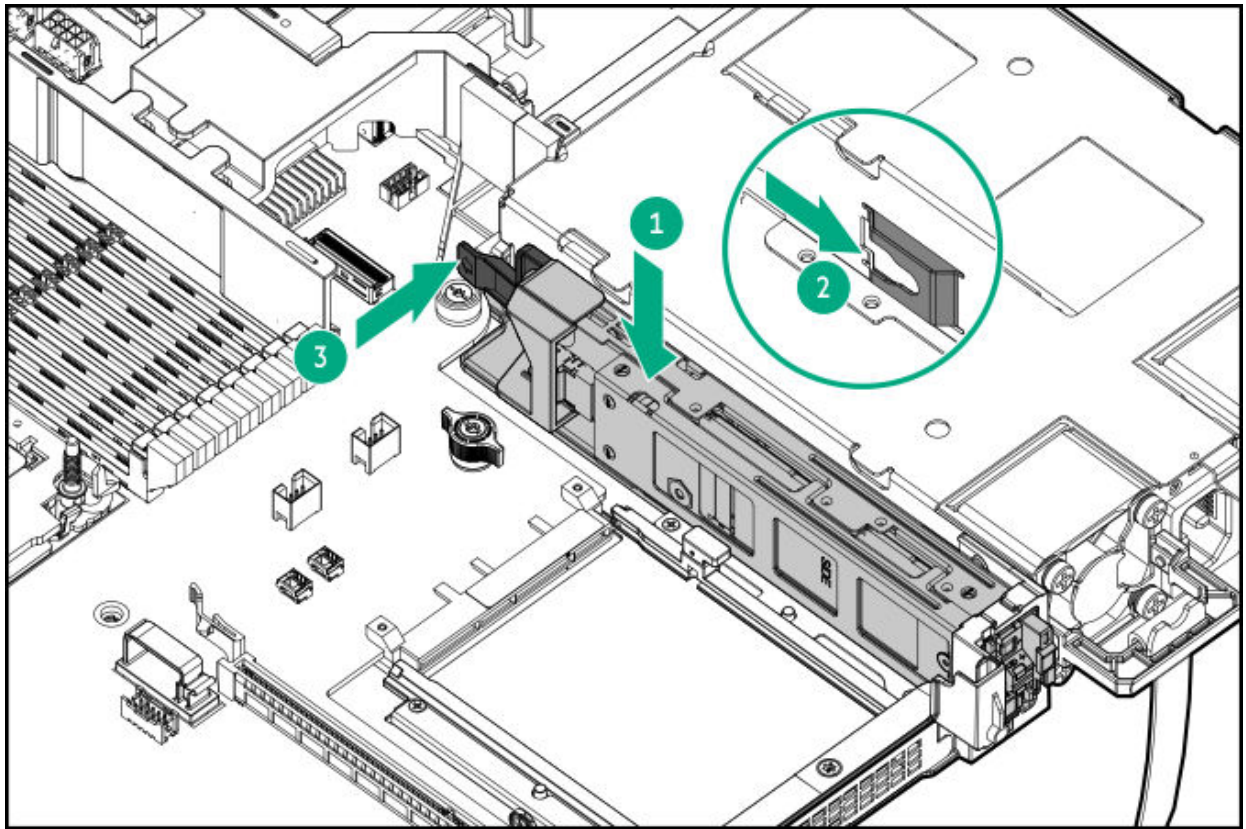

- .6. Cable the boot device.
- .7. Install the secondary riser cage.
- .8. Install the access panel.
- .9. Install the server into the rack.
- !0. Connect all peripheral cables to the server.
- !1. Connect the power cords:
 - a. Connect each power cord to the server.
 - b. Connect each power cord to the power source.
- !2. If installed, close the cable management arm.

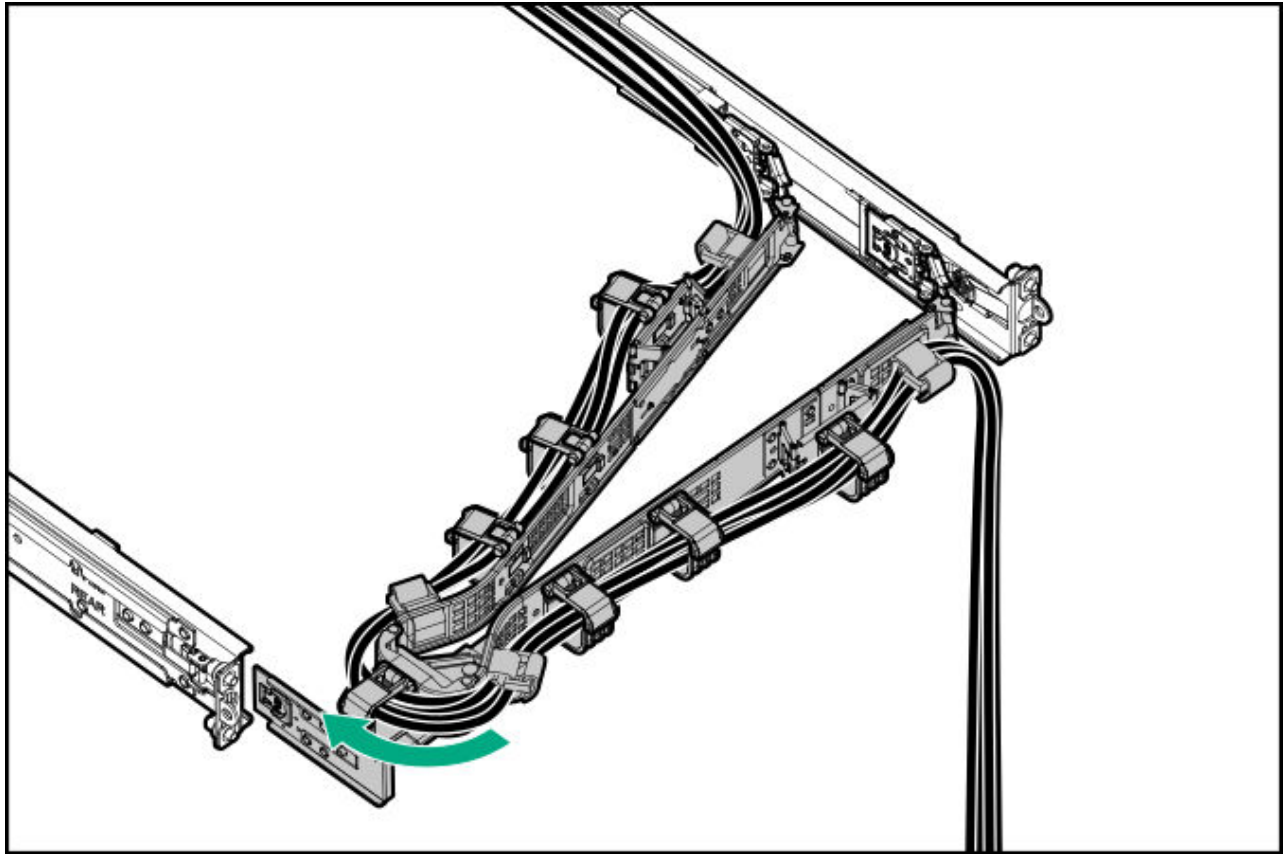

!3. Power up the server.

!4. If removed, install the front bezel.

Results

The installation procedure is complete.

M.2 SSD options

The server supports the installation of M.2 SATA and NVMe SSD options for:

- Booting up from flash solution
- Data backup/redundancy

In this server, M.2 SSD support is provided through the following options:

- Installing the HPE NS204i-u controller option
- Installing an M.2 SSD

Subtopics

Installing an M.2 SSD

Installing an M.2 SSD

Prerequisites

- Use Intel VROC to configure M.2 SSDs.
- If you are installing M.2 NVMe SSDs, the Intel VROC Standard license is required to support the RAID 0/1 configuration. For more information on Intel VROC licenses, see the product QuickSpecs:

<https://www.hpe.com/info/quickspecs>

- Before beginning installation, make sure that the server is updated with the latest operating system firmware and drivers.
- Before beginning installation, make sure that the server is updated with the latest operating system firmware and drivers.
- Before you perform this procedure, make sure that you have a Phillips No. 1 screwdriver available.

About this task



CAUTION

A discharge of static electricity from a finger or other conductor might damage system boards or other static-sensitive devices. To prevent damage, observe antistatic precautions.

Procedure

1. Power down the server.
2. If installed, open the cable management arm.
3. Remove all power:
 - a. Disconnect each power cord from the power source.
 - b. Disconnect each power cord from the server.
4. Disconnect all peripheral cables from the server.
5. Remove the server from the rack.
6. Place the server on a flat, level work surface.

7. Remove the access panel.
8. Remove the M.2 air baffle.
9. Remove the SSD jack screw from the M.2 location where you intend to install the new SSD.

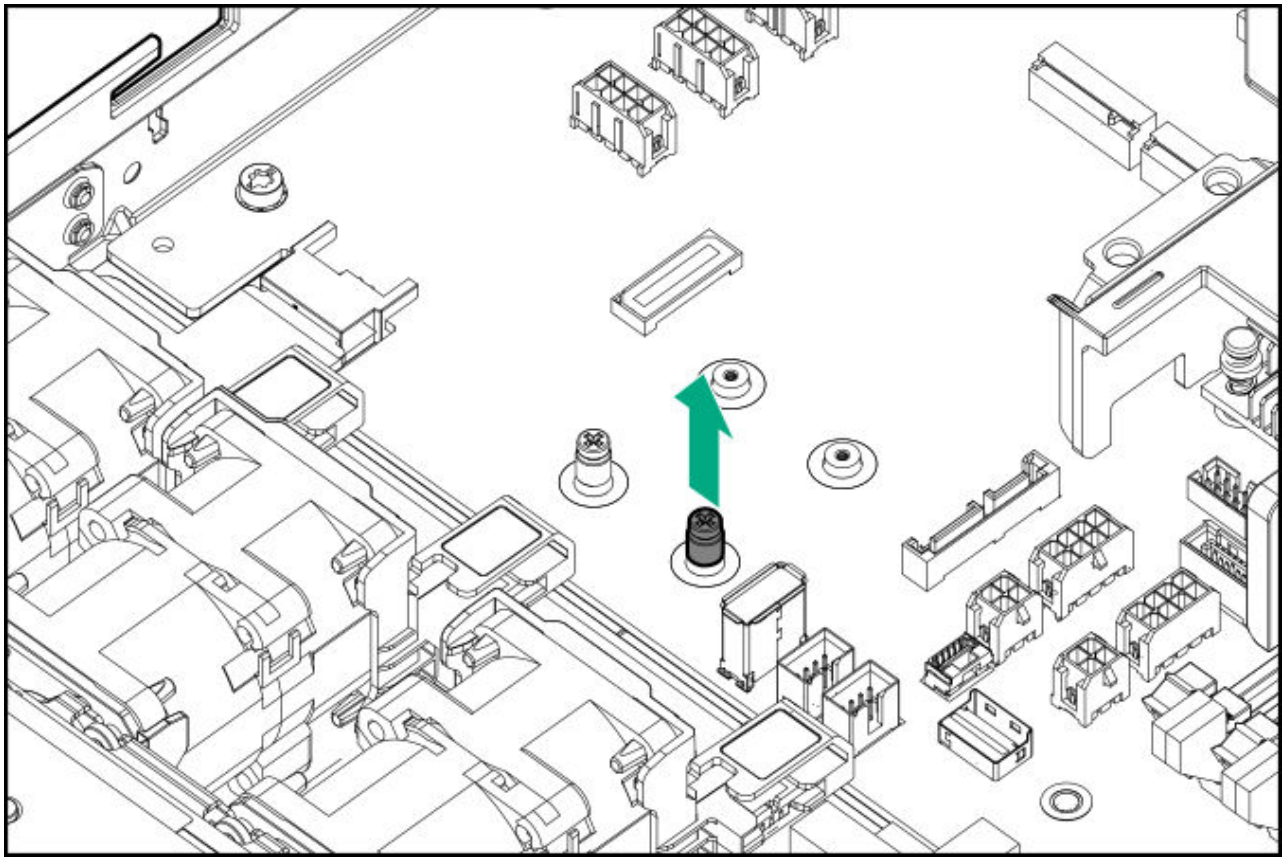

- .0. Install the M.2 SSD:
 - a. Insert the SSD into the M.2 slot.
 - b. Position the jack screw on the SSD notch.

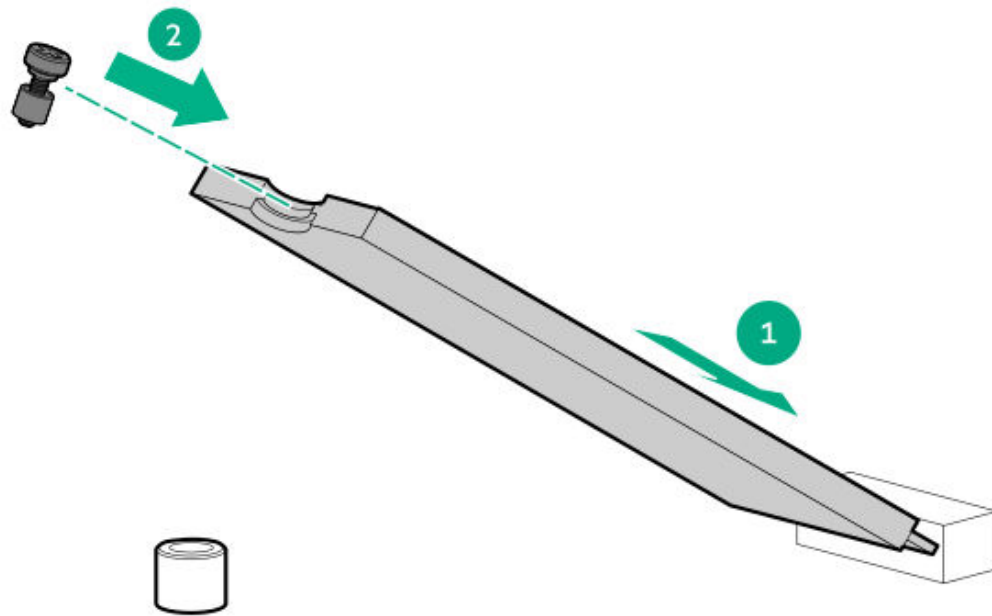

- c. Carefully press the SSD down to the horizontal position.
- d. Tighten the SSD jack screw.

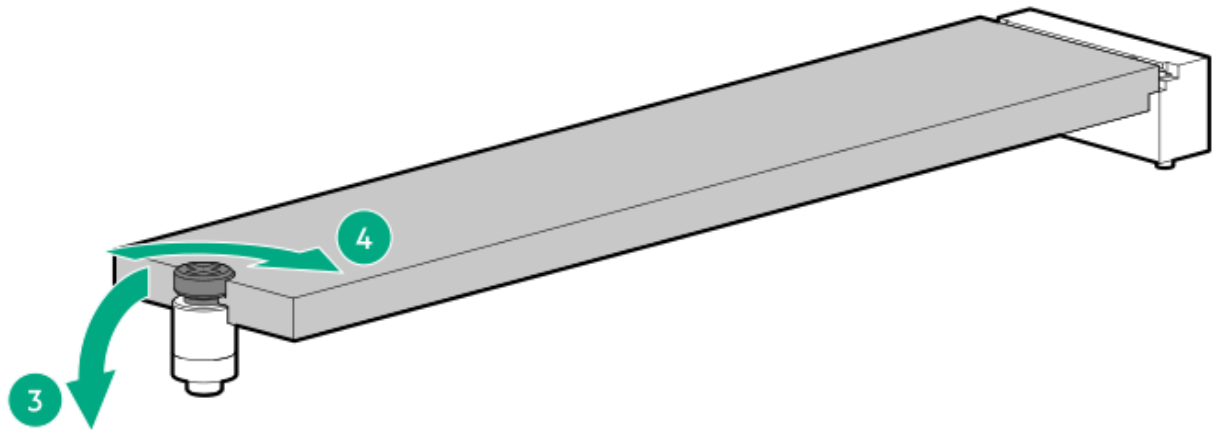

- .1. Install the M.2 air baffle.
- .2. Install the access panel.
- .3. Install the server into the rack.
- .4. Connect all peripheral cables to the server.
- .5. Connect the power cords:
 - a. Connect each power cord to the server.
 - b. Connect each power cord to the power source.

.6. If installed, close the cable management arm.

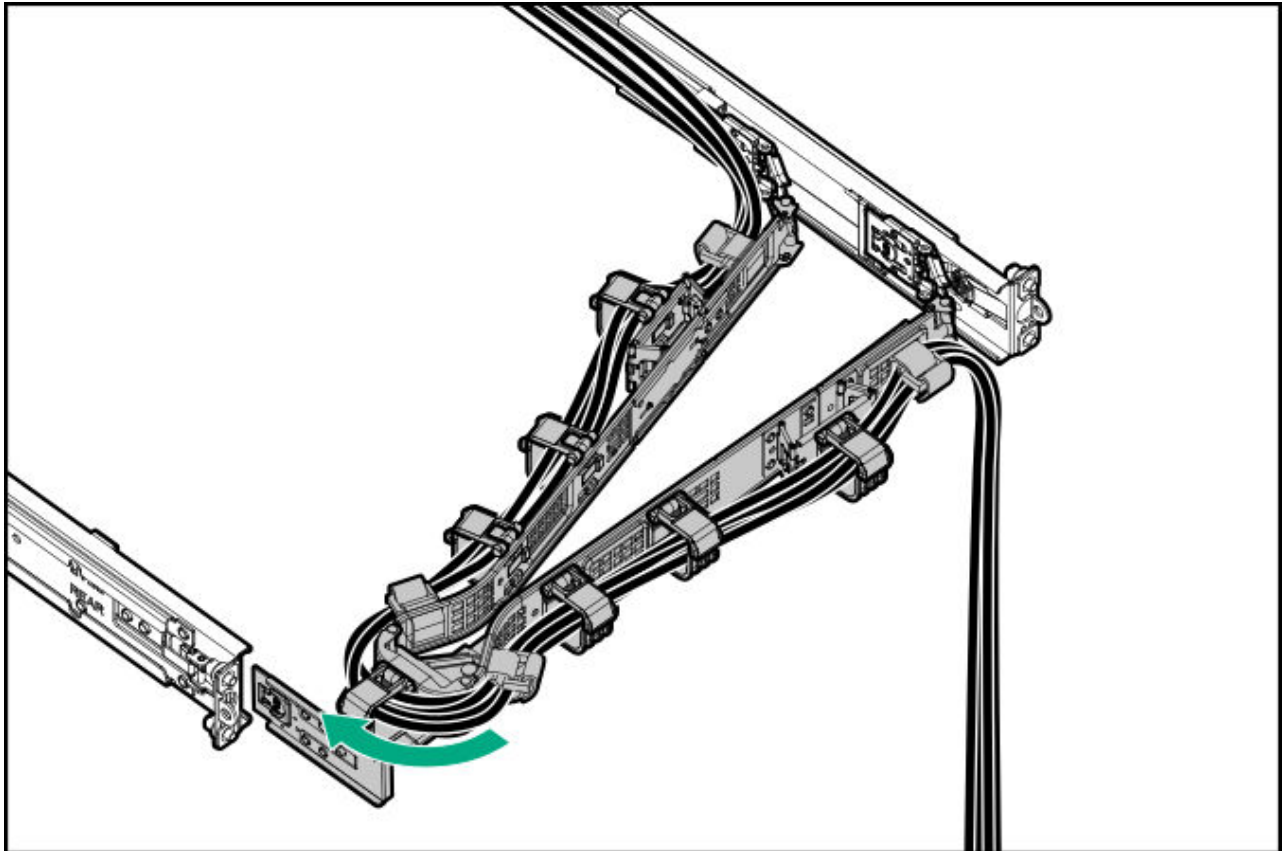

.7. Power up the server.

Results

The installation procedure is complete.

Processor heatsink assembly option

Subtopics

Processor cautions

Installing a processor heatsink assembly

Reconfiguring the system date and time settings

Processor cautions



CAUTION

To avoid damage to the processor or system board, only authorized personnel should attempt to replace or install the processor in this server.



CAUTION

To prevent possible server malfunction and damage to the equipment, multiprocessor configurations must contain processors with the same part number.



CAUTION

The pins on the processor socket and on the processor are very fragile and easily damaged. To avoid component damage, **do not touch these pins.** Any damage to them might require replacing the system board and/or processor.



IMPORTANT

Processor socket 1 must be populated at all times or the server does not function.



IMPORTANT

If installing a processor with a faster speed, update the system ROM before installing the processor. To download firmware, see [Updating firmware or system ROM](#).



IMPORTANT

After removing a processor from the system board, the server resets the date and time. For information on reconfiguring these settings, see [Reconfiguring the system date and time settings](#).

Installing a processor heatsink assembly

Prerequisites

Before you perform this procedure, make sure that you have a T-30 Torx screwdriver available.

About this task

This server supports Intel® Xeon® Scalable Processor XCC and Intel® Xeon® Scalable Processor MCC where the keying features are different between the two processors. The processor carrier clip for an Intel® Xeon® Scalable Processor XCC is E1A. The processor carrier clip for an Intel® Xeon® Scalable Processor MCC is E1B.



CAUTION

A discharge of static electricity from a finger or other conductor might damage system boards or other static-sensitive devices. To prevent damage, observe antistatic precautions.

Procedure

1. Power down the server.
2. If installed, open the cable management arm.
3. Remove all power:
 - a. Disconnect each power cord from the power source.
 - b. Disconnect each power cord from the server.
4. Disconnect all peripheral cables from the server.
5. Remove the server from the rack.
6. Place the server on a flat, level work surface.
7. Remove the access panel.
8. Remove the protective film from the thermal interface material.



CAUTION

To prevent mechanical damage or depositing oil on your hands or other contaminants to the heatsink contact surface, hold the heatsink only by the edge of its base plate. Do not touch the heatsink fins.

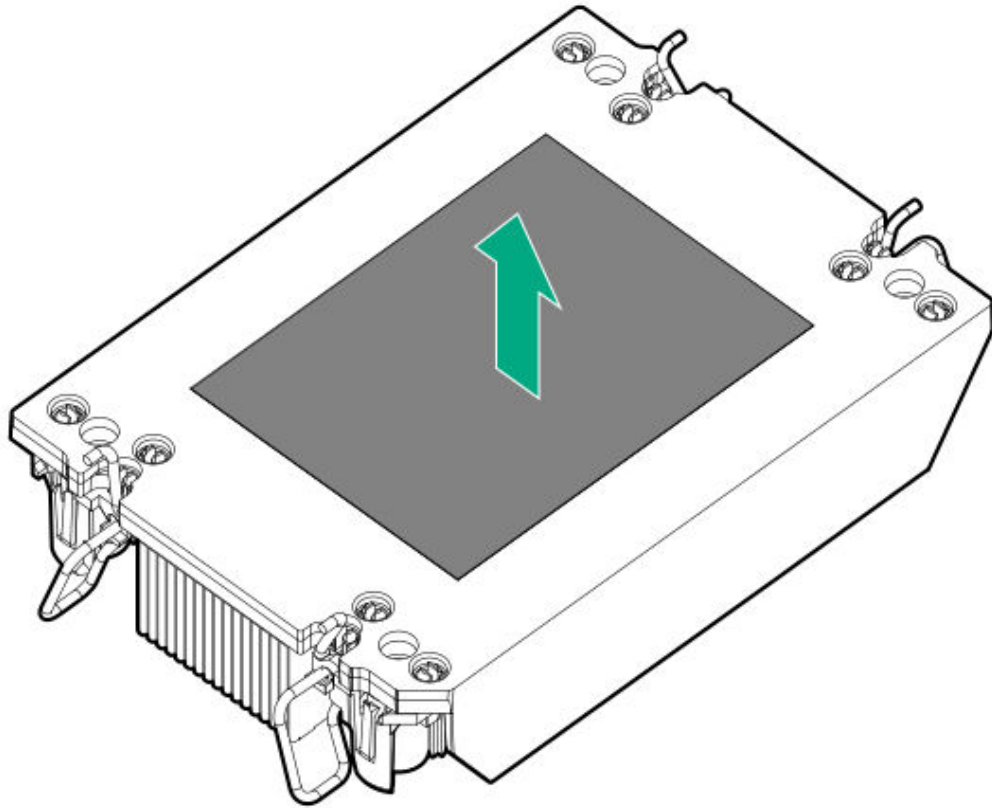

9. Verify that the processor is securely latched to the processor carrier.

The following illustration calls out the keying feature tabs that secure the processor. Different processor carriers will have these tabs in different locations.

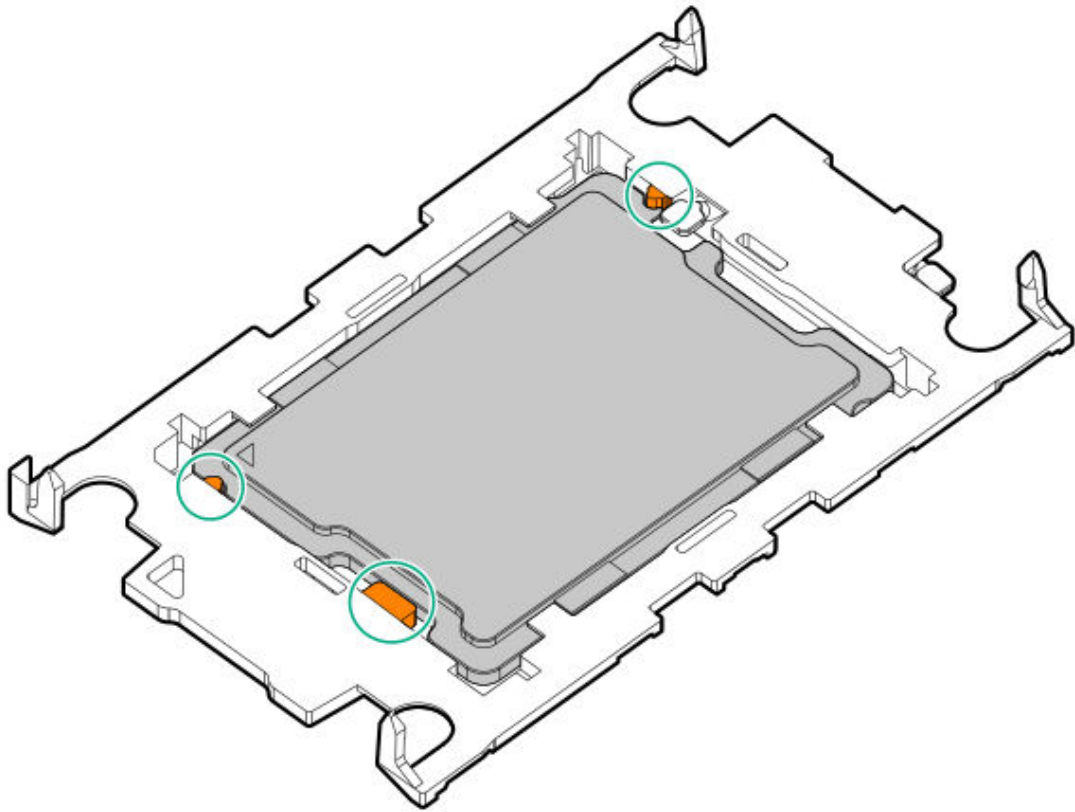

.0. Attach the heatsink to the processor carrier:

- a. Align the pin 1 indicator on the processor carrier with that on the heatsink.

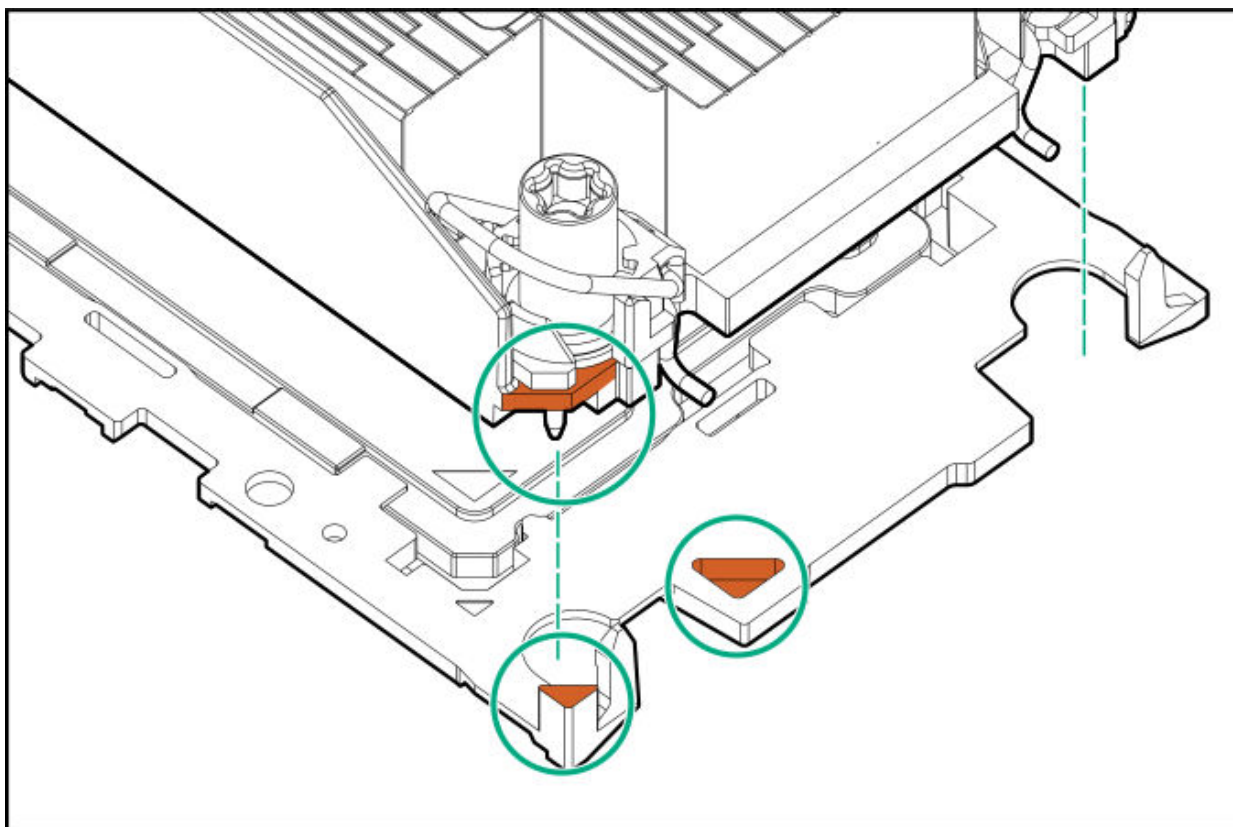

b. Lower the heatsink on the processor carrier until the carrier tabs snap into place.

There will be an audible click to indicate that the heatsink is properly latched on the processor carrier.

- Standard heatsink

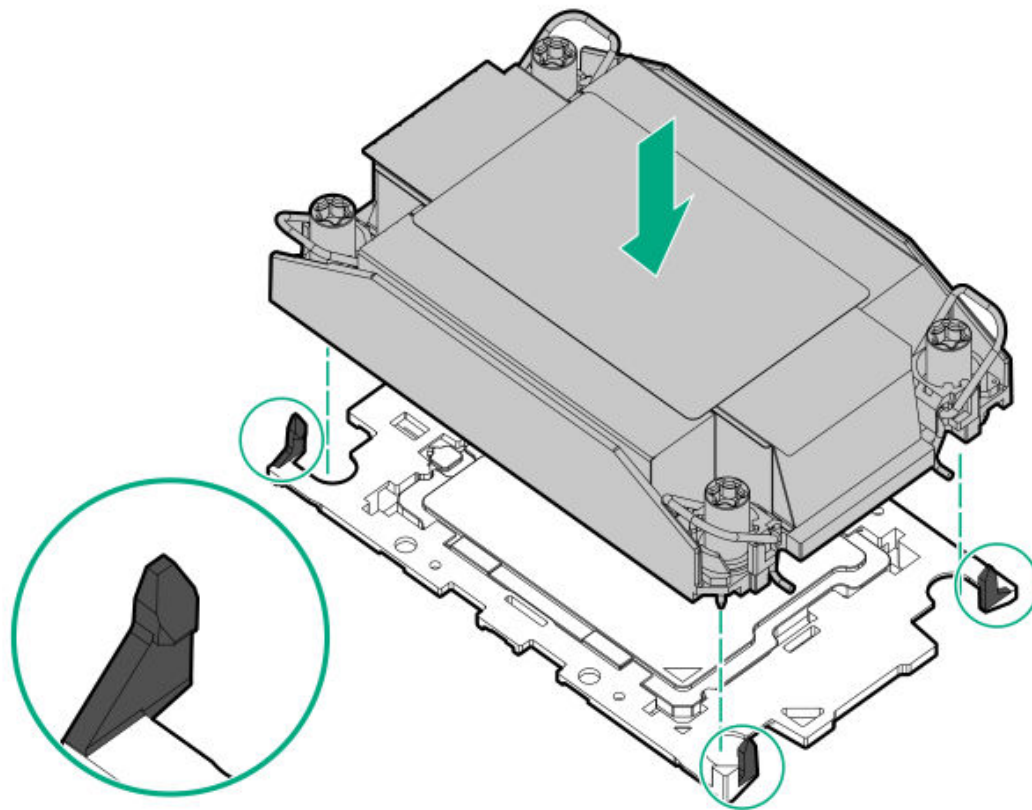

- Performance heatsink

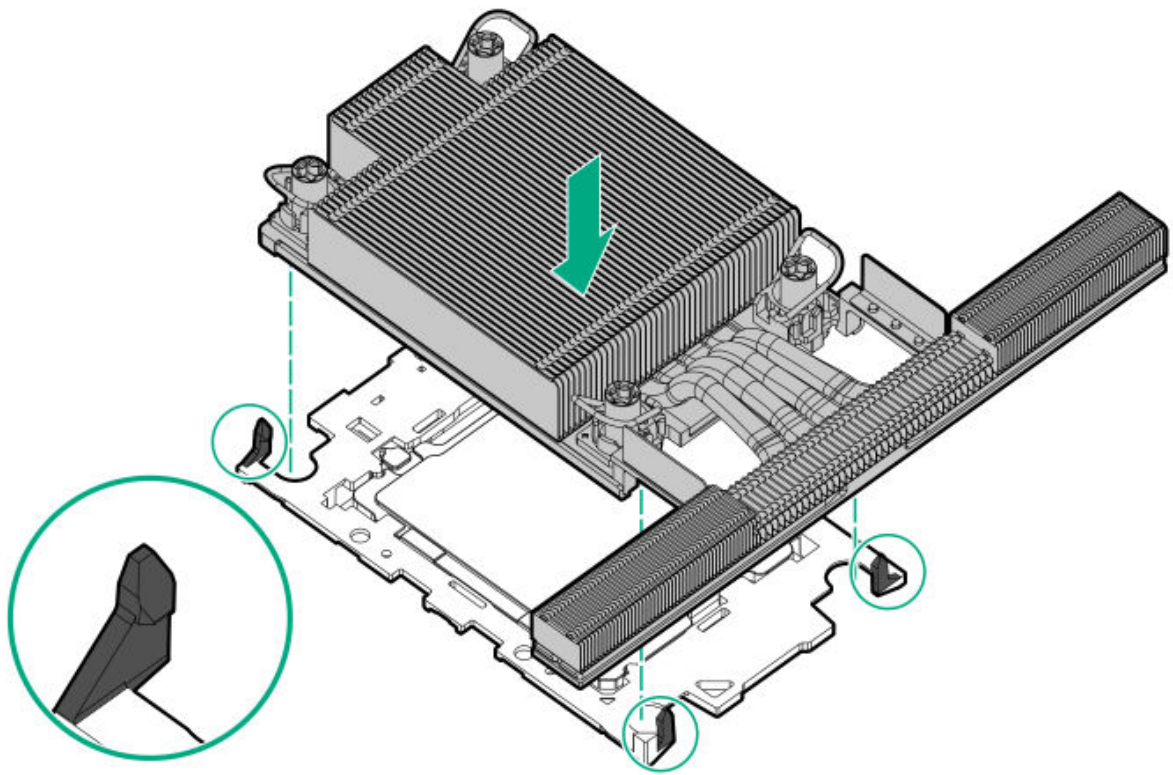

.1. Perform the following verification steps:

- a. Verify that the tabs on the processor carrier are securely latched on the heatsink.

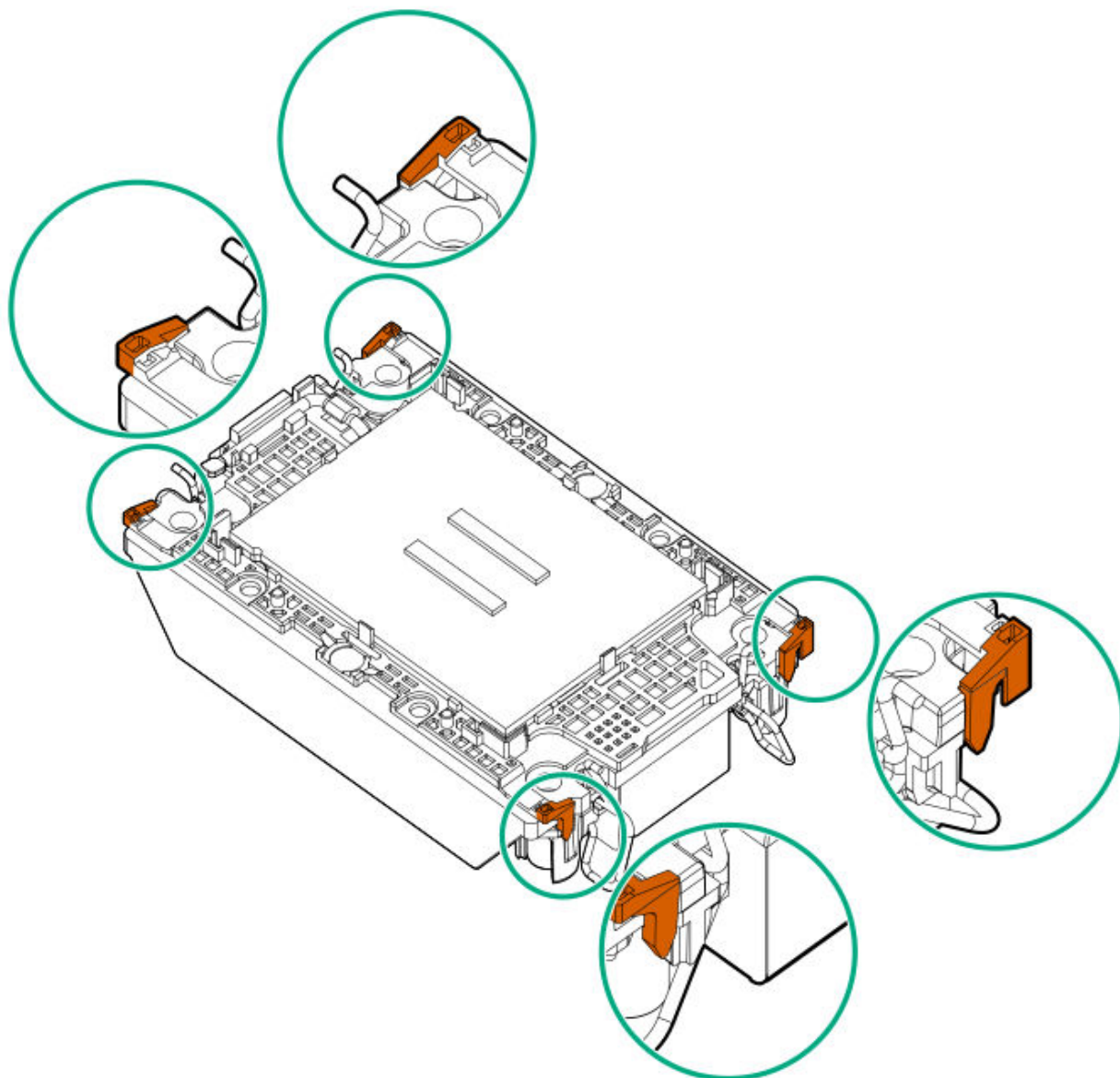

b. Verify that the pin 1 indicators on the processor and processor carrier are aligned.

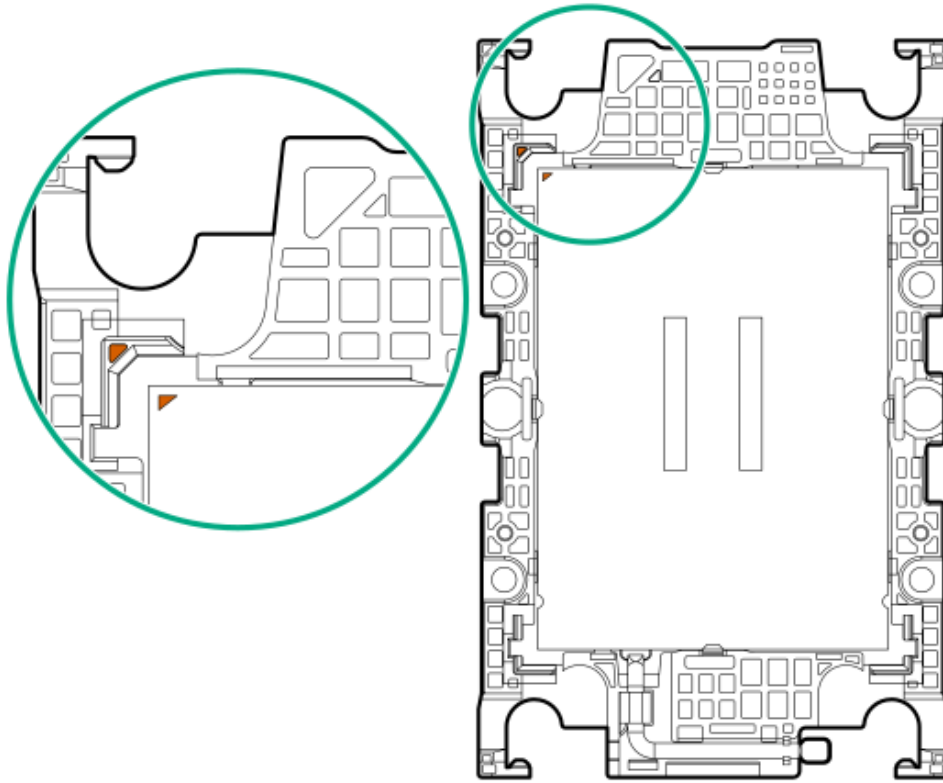

c. Verify that the processor is properly secured by the carrier snaps.

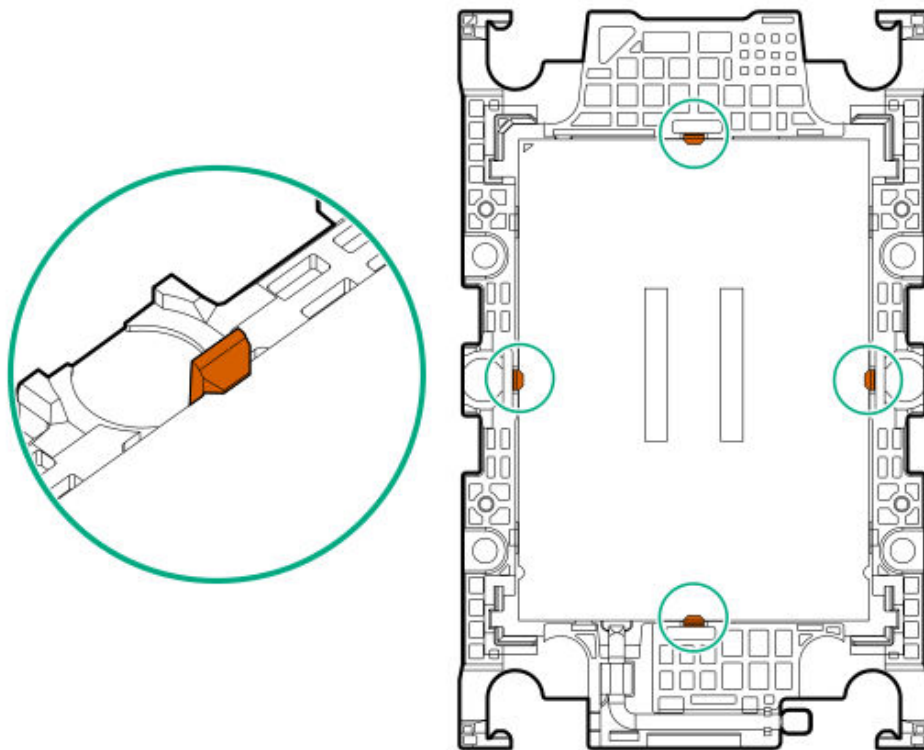

- .2. Remove the dust cover from the processor socket:
 - a. Press and hold the grip tabs on the dust cover.
 - b. Lift the dust cover away from the bolster plate.

Retain the cover for future use.

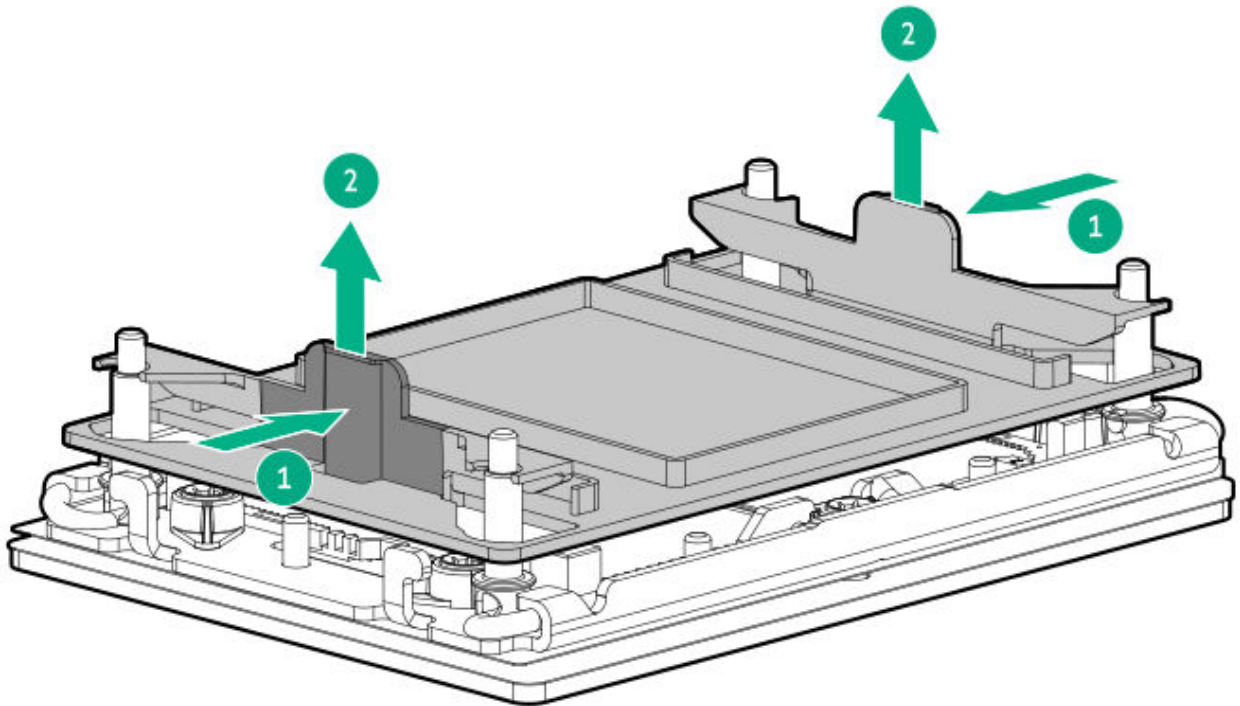

.3.



CAUTION

To prevent thermal failure or component damage, do not move the heatsink once the bottom of its base plate touches the top of the processor. Excessive heatsink movement can cause the thermal grease to smear and become uneven. Voids in the compound can adversely impact the transfer of heat away from the processor.

Install the processor-heatsink module:

- a. When using a torque wrench to tighten the heatsink screws, set 0.9 N-m (8 in-lb) of torque.
- b. Note the **Front of server** text on the heatsink label to correctly orient the processor-heatsink module over the bolster plate.
- c. Carefully lower the processor-heatsink module straight down onto the bolster plate guide posts.

The posts are keyed so that the module can only be installed one way. Make sure that the module is properly seated on the bolster plate before securing the screws.

- Standard heatsink

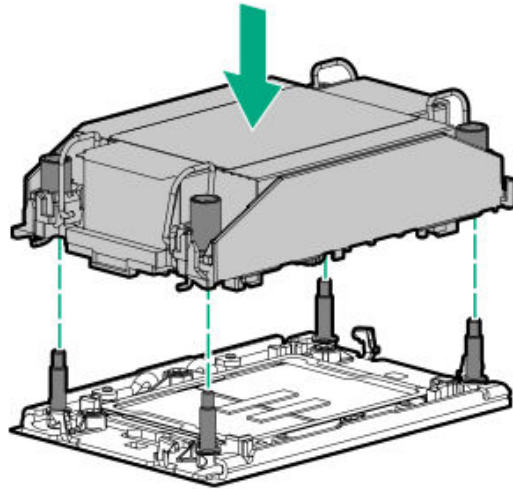

- Performance heatsink

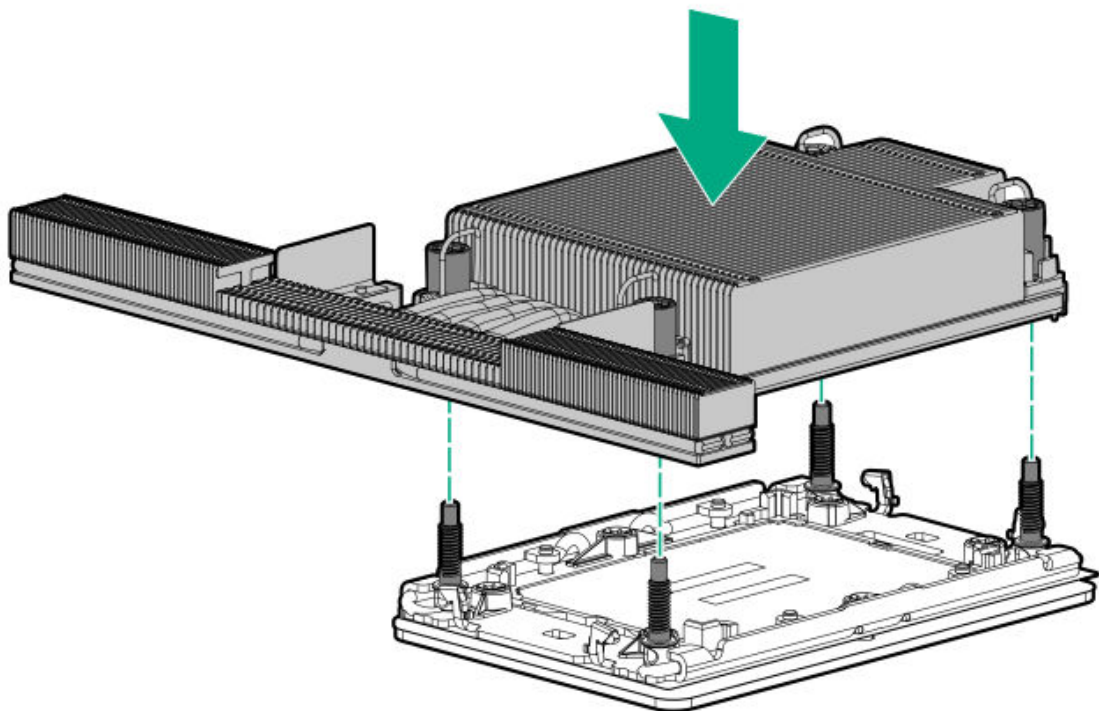

d. Set the anti-tilt wires to the locked position.

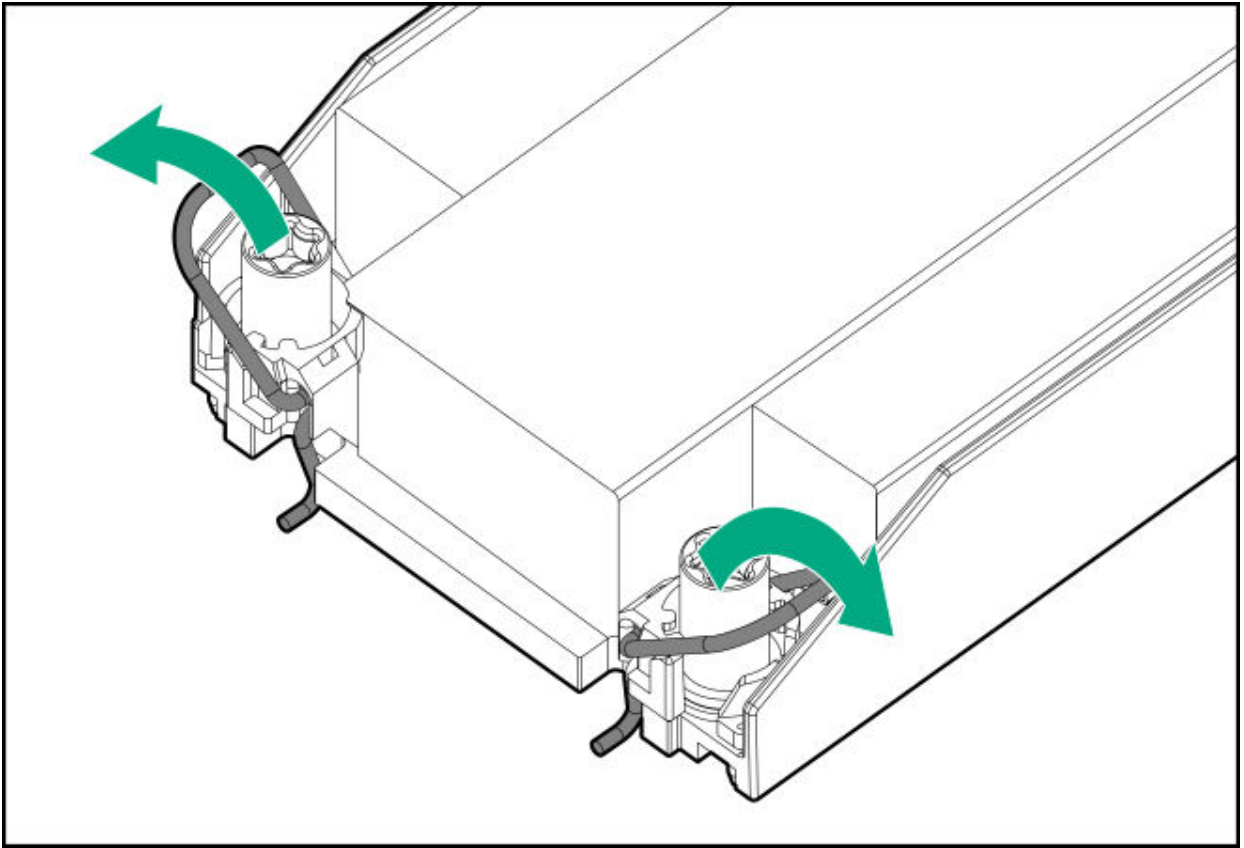

e. Tighten one pair of diagonally opposite heatsink screws, and then tighten the other pair of heatsink screws.

- Standard heatsink

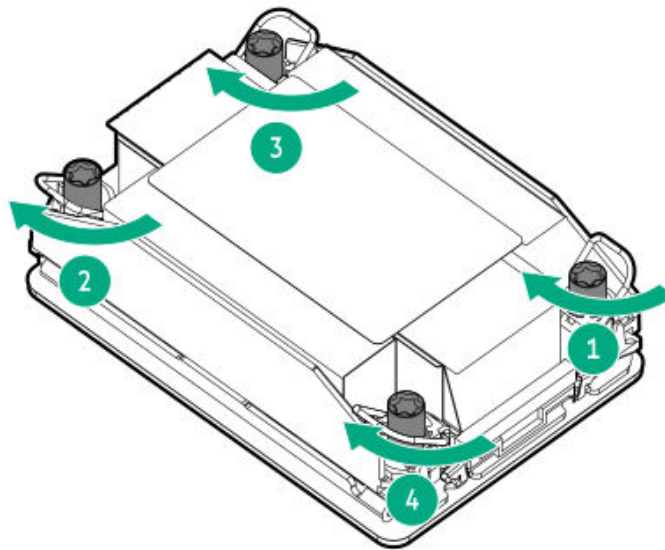

- Performance heatsink

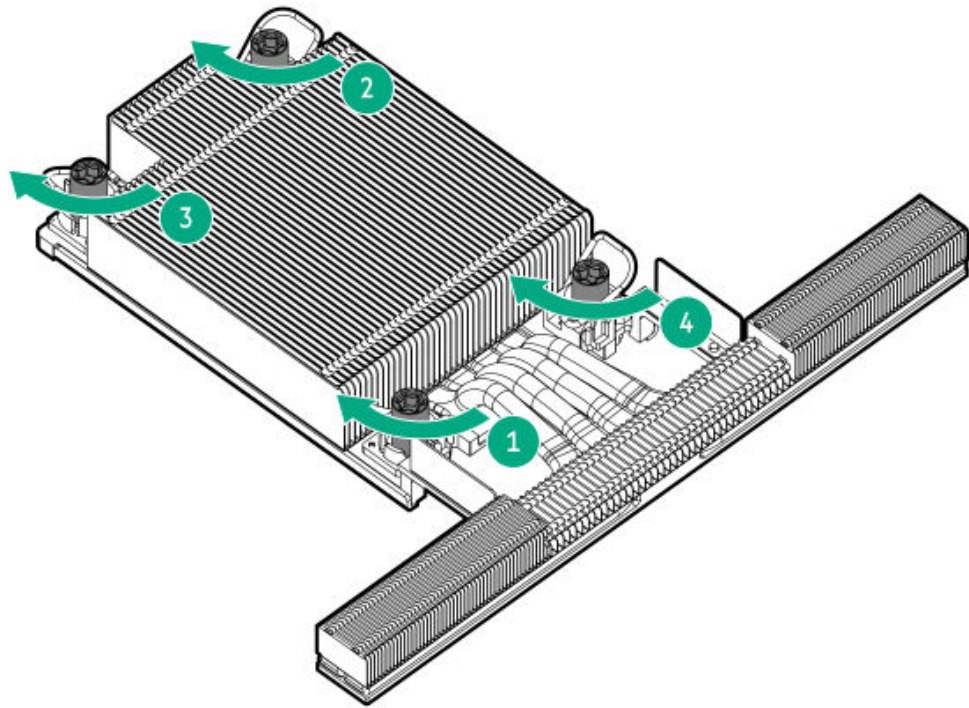

- .4. Install the access panel.
- .5. Install the server into the rack.
- .6. Connect all peripheral cables to the server.
- .7. Connect the power cords:
 - a. Connect each power cord to the server.
 - b. Connect each power cord to the power source.
- .8. If installed, close the cable management arm.

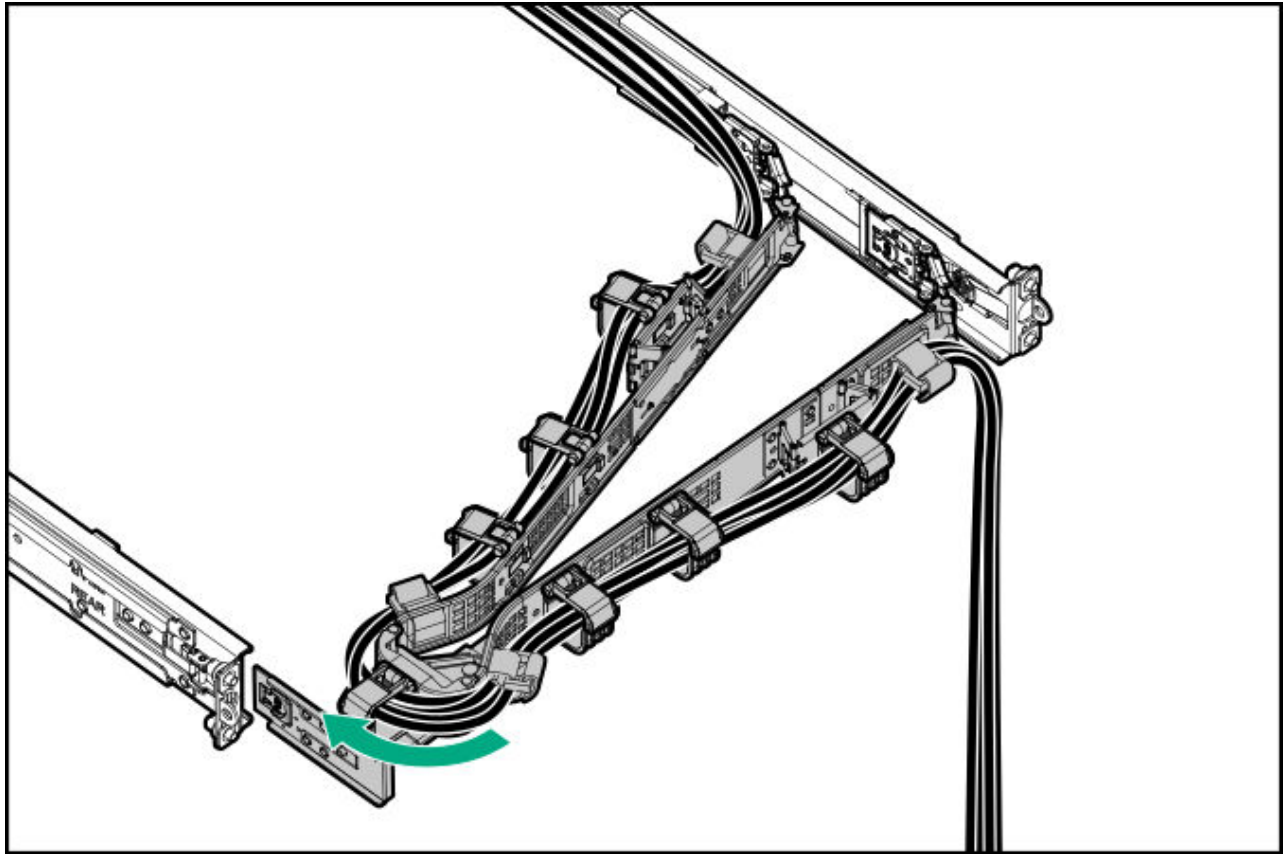

9. Power up the server.
10. Reconfigure the system date and time settings.

Results

The installation procedure is complete.

Reconfiguring the system date and time settings

Procedure

1. Access the UEFI System Utilities. During POST, press **F9**.
2. From the **System Utilities** screen, select **System Configuration > BIOS/Platform Configuration (RBSU) > Date and Time**.
3. Select a setting, and then complete your entry.
 - **Date (mm-dd-yyyy)**—Enter the date in a month-day-year (mm-dd-yyyy) format.
 - **Time (hh:mm:ss)**—Enter the time in a 24-hour format (hh:mm:ss) format.

- **Hour Format**—Select either a 12- or 24-hours format.
- **Time Format**
 - **Coordinated Universal Time (UTC)**—Calculates the time stored in the hardware real-time clock (RTC) from the associated **Time Zone** setting.
 - **Local Time**—Removes the use of the **Time Zone** setting. This option is useful for addressing interaction issues in Windows operating systems set in legacy BIOS boot mode.
- **Time Zone**—Select the time zone for the system.
- **Daylight Savings Time**
 - **Enabled**—Adjusts the local time displayed by one hour for Daylight Savings Time.
 - **Disabled**—Does not adjust the local time displayed for Daylight Savings Time.

4. To confirm and save the settings, press **F12**.

The server automatically reboots.

Serial port option

Install the serial port option to enable communication to physical serial devices. You can also use the serial connection to remotely access the system BIOS and view POST error messages.

Subtopics

Installing the serial port

Installing the serial port

Prerequisites

Before you perform this procedure, make sure that you have the following items available:

- Hex screwdriver
- Spudger or any small prying tool

About this task



CAUTION

A discharge of static electricity from a finger or other conductor might damage system boards or other static-sensitive devices. To prevent damage, observe antistatic precautions.



CAUTION

The port blank provides EMI shielding and helps maintain proper thermal status inside the server. Do not operate the server when a port blank is removed without the corresponding I/O port option installed.

Procedure

1. Power down the server.
2. If installed, open the cable management arm.
3. Remove all power:
 - a. Disconnect each power cord from the power source.
 - b. Disconnect each power cord from the server.
4. Disconnect all peripheral cables from the server.
5. Remove the server from the rack.
6. Place the server on a flat, level work surface.
7. Remove the access panel.
8. Remove the primary riser cage.
9. Remove the serial port blank.

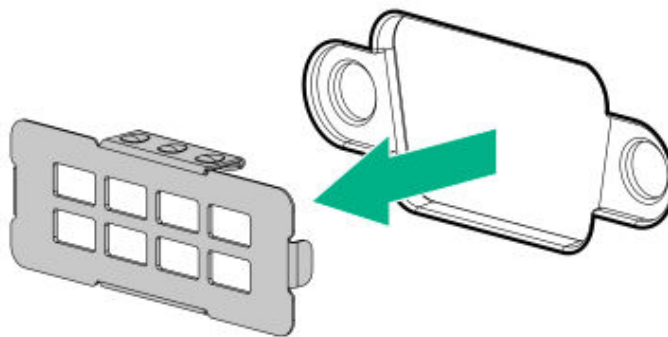

- .0. Install the serial port cable:
 - a. Insert the serial port into the rear panel opening.
 - b. Install the hex screws.

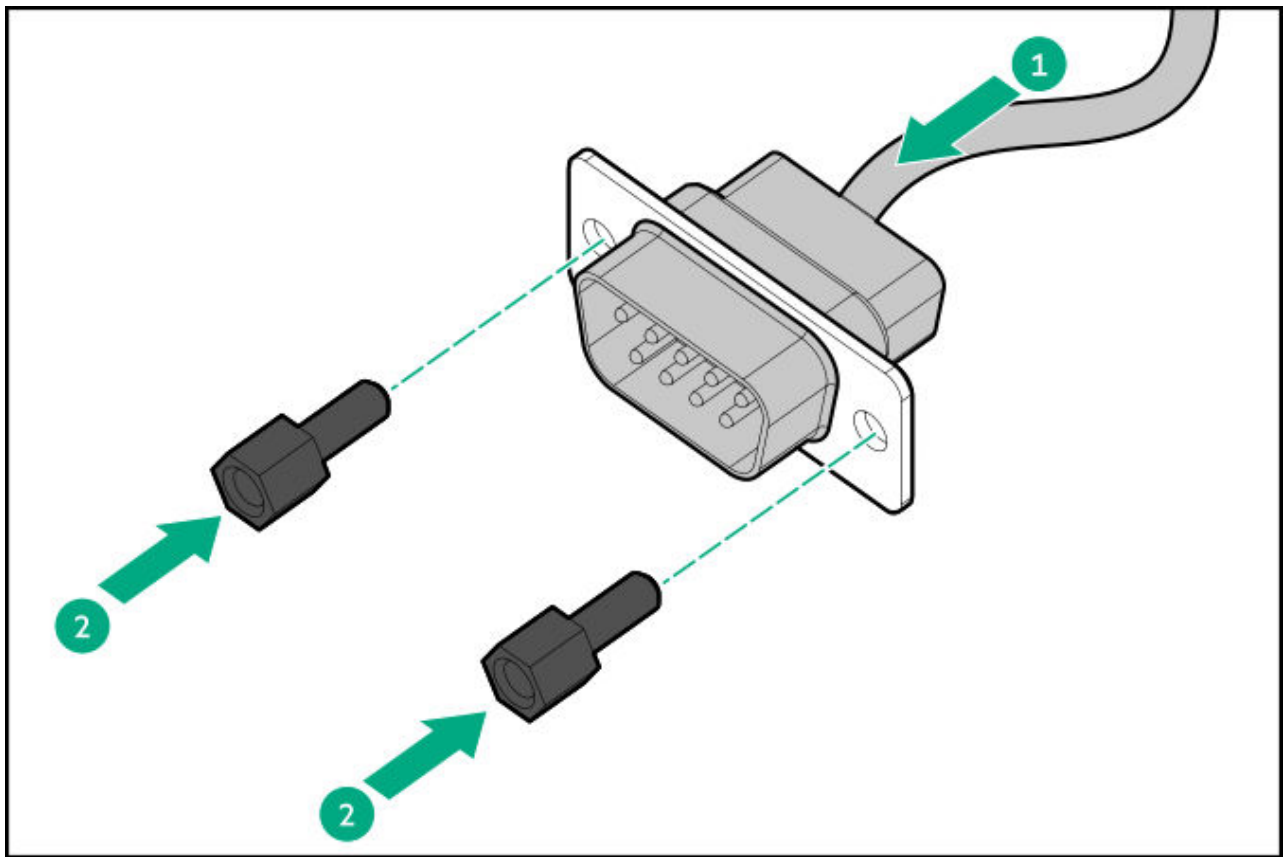

- .1. Cable the serial port.
- .2. Install the primary riser cage.
- .3. Install the access panel.
- .4. Install the server into the rack.
- .5. Connect all peripheral cables to the server.
- .6. Connect the power cords:
 - a. Connect each power cord to the server.
 - b. Connect each power cord to the power source.
- .7. If installed, close the cable management arm.

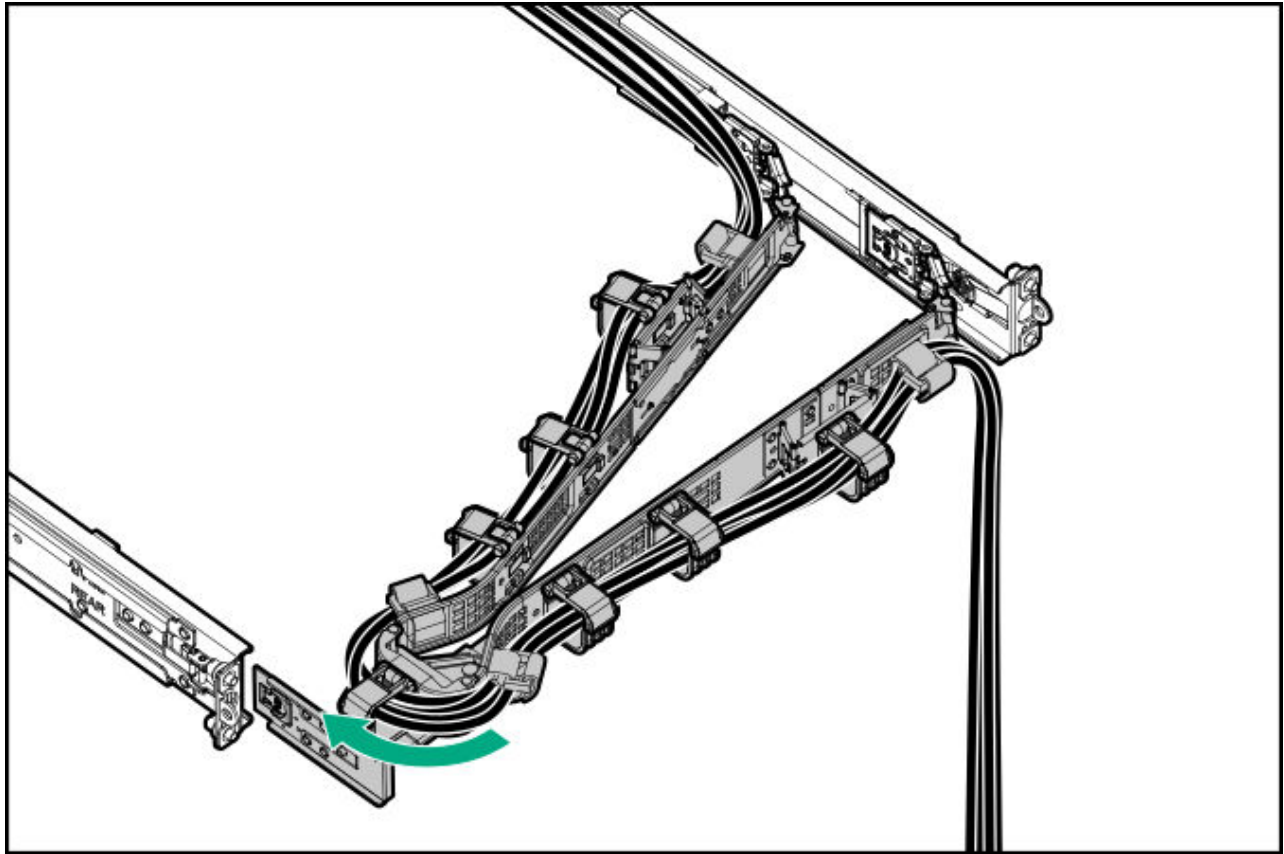

.8. Power up the server.

Results

The installation procedure is complete.

Chassis intrusion detection switch option

The chassis intrusion detection switch enables iLO to record an event in the Integrated Management Log (IML) whenever the access panel is physically opened or removed. An alert is also sent to the BIOS whenever a chassis intrusion is detected. The chassis intrusion detection occurs as long as the server is plugged in, regardless of whether the server is powered on or off.

Subtopics

Installing the chassis intrusion detection switch

Installing the chassis intrusion detection switch

Procedure

1. Power down the server.
2. If installed, open the cable management arm.
3. Remove all power:
 - a. Disconnect each power cord from the power source.
 - b. Disconnect each power cord from the server.
4. Disconnect all peripheral cables from the server.
5. Remove the server from the rack.
6. Place the server on a flat, level work surface.
7. Remove the access panel.
8. Remove the M.2 air baffle.
9. Install the chassis intrusion detection switch:
 - a. Insert the alignment pins on the middle DIMM guard through the holes on the switch.
 - b. Route the rest of the cable.

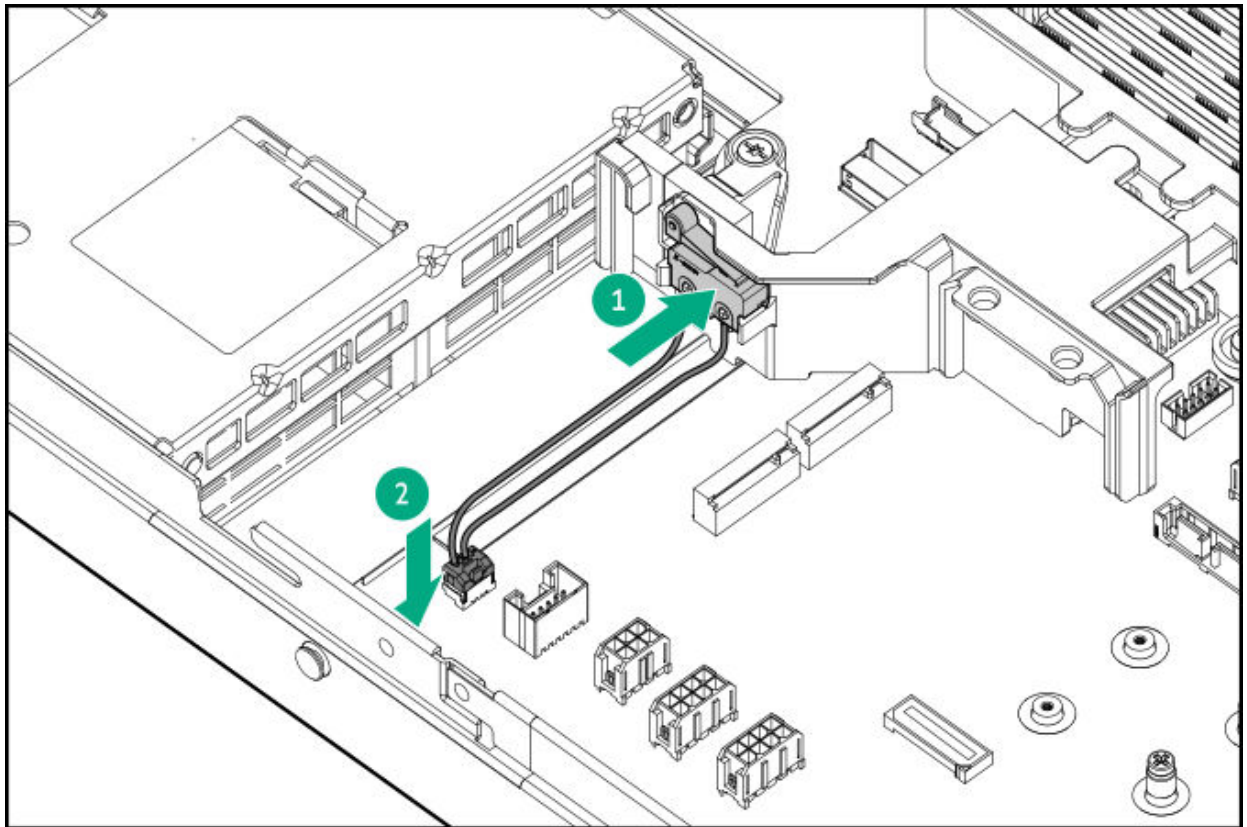

- .0. Install the M.2 air baffle.
- .1. Install the access panel.
- .2. Install the server into the rack.
- .3. Connect all peripheral cables to the server.
- .4. Connect the power cords:
 - a. Connect each power cord to the server.
 - b. Connect each power cord to the power source.
- .5. If installed, close the cable management arm.

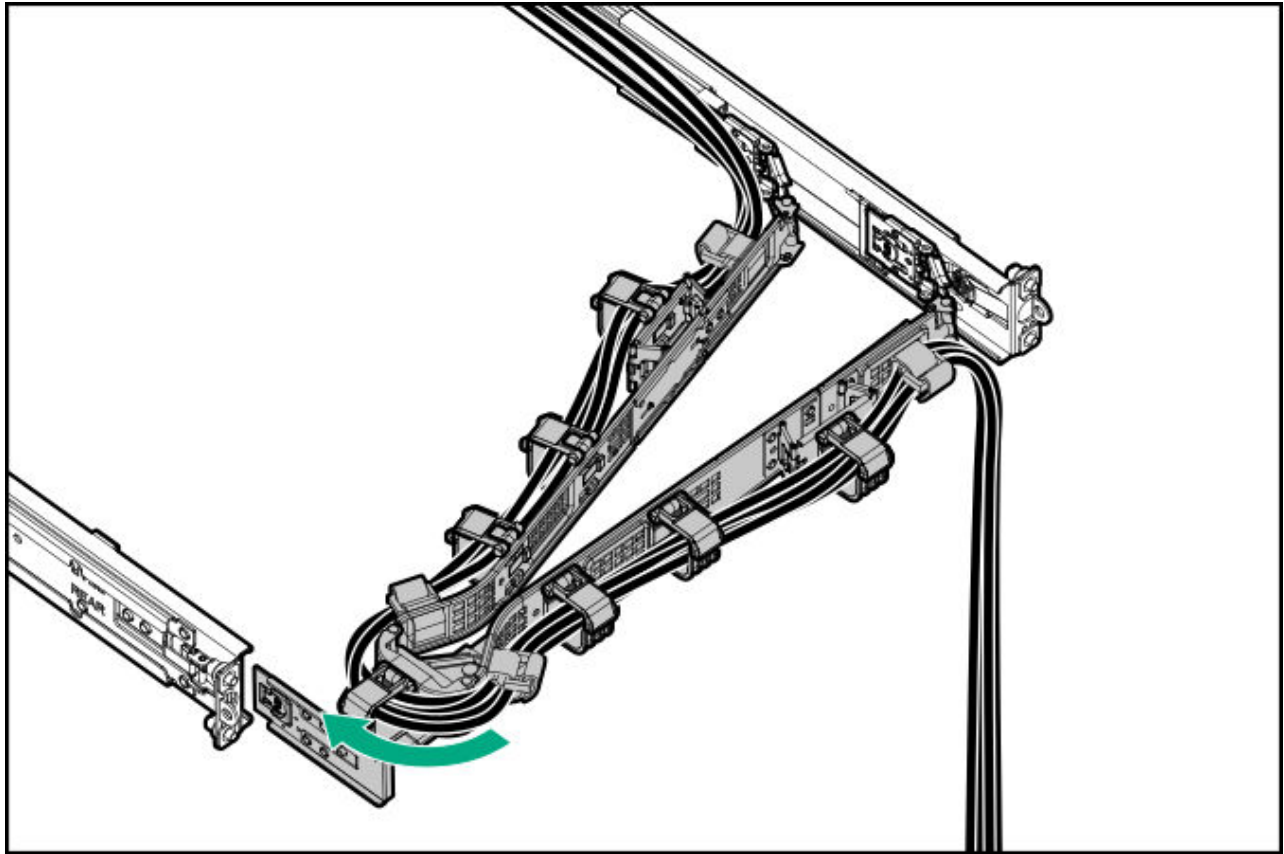

.6. Power up the server.

Results

The installation procedure is complete.

The **System Intrusion Detection** setting in the UEFI System Utilities is automatically enabled after installing the chassis intrusion detection switch. To view a log of intrusion events, use the iLO web interface to access the IML or the iLO event log. For more information, see the iLO user guide on the Hewlett Packard Enterprise website (<https://www.hpe.com/support/ilo-docs>).

Internal USB device option

The server has an internal USB 2.0 port to install a USB device that can be used as a flash boot media or for data backup/redundancy.

Subtopics

Installing an internal USB device

Installing an internal USB device

Procedure

1. Power down the server.
2. Remove all power:
 - a. Disconnect each power cord from the power source.
 - b. Disconnect each power cord from the server.
3. Disconnect all peripheral cables from the server.
4. Do one of the following:
 - a. Extend the server from the rack.
 - b. Remove the server from the rack.
5. Remove the access panel.
6. Locate the internal USB port.
7. Remove the primary riser cage.
8. Plug in the USB device into the USB port.



9. Install the primary riser cage.
0. Install the access panel.
1. Install the server into the rack.
2. Connect all peripheral cables to the server.
3. Connect the power cords:
 - a. Connect each power cord to the server.

b. Connect each power cord to the power source.

4. Power up the server.

Results

The installation procedure is complete.

Configuration resources

Use the following resources to find documentation for configuring and managing your server.

- Some utilities might not apply to your server. For information about server compatibility with the products listed in this chapter, see the product QuickSpecs (<https://www.hpe.com/info/quickspecs>).
- Products ordered from HPE Factory Express might have already been configured with some or all the configurations in this chapter. To determine if any additional setup is required, see your HPE Factory Express order.
- For one-stop access to version-specific software and firmware documentation, including the latest product release notes, see this quick links page:
<https://www.hpe.com/support/hpeproductdocs-quicklinks>

Subtopics

[Updating firmware or system ROM](#)

[Configuring the server](#)

[Configuring storage controllers](#)

[Deploying an OS](#)

[Configuring security](#)

[Server management](#)

[Managing Linux-based high performance compute clusters](#)

Updating firmware or system ROM

To

Use

Download service packs

- Service Pack for ProLiant (SPP)

To	Use
	<p>https://www.hpe.com/servers/spp/download</p> <ul style="list-style-type: none"> Get an overview of SPP and its ecosystem <p>https://www.hpe.com/support/SPP-overview-views-en</p>
Deploy service packs to a single server	<p>Smart Update Manager (SUM)</p> <p>https://www.hpe.com/support/hpesmartupdatemanager-quicklinks</p>
Deploy service packs to multiple servers	<p>HPE OneView</p> <p>https://www.hpe.com/support/hpeoneview-quicklinks</p>
Updating iLO or system firmware in a single server or multiple servers	<p>HPE iLO</p> <p>https://www.hpe.com/support/hpeilodocs-quicklinks</p>
<ul style="list-style-type: none"> Enable policy-based management of server or server group firmware for distributed server infrastructure Monitor server compliance with a configured firmware baseline Receive automatic iLO firmware updates Receive baseline update alerts 	<p>HPE Compute Ops Management</p> <p>https://www.hpe.com/support/hpe-gl-com-quicklinks</p>

Configuring the server

To configure	Use
Single server (GUI)	<ul style="list-style-type: none"> Intelligent Provisioning <p>https://www.hpe.com/support/hpeintelligentprovisioning-quicklinks</p>

To configure

Use

	<ul style="list-style-type: none">• iLO remote console or web interface <u>https://www.hpe.com/support/hpeilodocs-quicklinks</u>• UEFI System Utilities <u>https://www.hpe.com/support/hpeuefisystemutilities-quicklinks</u>• HPE Compute Ops Management <u>https://www.hpe.com/support/hpe-gl-com-quicklinks</u>
Single server (scripting)	<ul style="list-style-type: none">• RESTful Interface Tool <u>https://www.hpe.com/support/restfulinterface/docs</u>• Python iLO Redfish Library (python-ilorest-library) <u>https://github.com/HewlettPackard/python-ilorest-library</u>• Scripting Tools for Windows Powershell <u>https://www.hpe.com/info/powershell/docs</u>• iLO RESTful API <u>https://servermanagementportal.ext.hpe.com/</u>• HPE Compute Ops Management API <u>https://developer.greenlake.hpe.com/</u>
Multiple servers (either UI or scripting)	<ul style="list-style-type: none">• HPE OneView ¹ <u>https://www.hpe.com/support/hpeoneview-quicklinks</u>• HPE Compute Ops Management <u>https://www.hpe.com/support/hpe-gl-com-quicklinks</u>

To configure

Use

- **Server settings:** Define server-specific parameters such as firmware baselines, and then apply them to server groups.
- **Server groups:** Organize servers into custom-defined sets with associated server settings, and then apply group-specific policies to create a consistent configuration across the servers in the group.

¹ For servers running HPE OneView, do not use another tool, such as iLO, to delete or change certain settings. For more information about using HPE OneView and iLO to manage the same server, see the iLO user guide at <https://www.hpe.com/support/hpeilodocs-quicklinks>.

Configuring storage controllers

Controller type

Documentation

HPE SR Gen10 controllers

- HPE Smart Array SR Controller Gen10 User Guide
<https://www.hpe.com/support/SR-Gen10-UG>
- SR Gen10 controller RAID creation:
<https://www.hpe.com/support/SR-RAID-creation>

HPE SR Gen11 controllers

- HPE SR Gen11 Controller User Guide
<https://hpe.com/support/SR-Gen11-UG>
- SR Gen11 controller RAID creation:
<https://www.hpe.com/support/SR-RAID-creation>

Configuration guides:

Controller type

Documentation

	<ul style="list-style-type: none">• HPE Smart Storage Administrator GUI User Guide https://www.hpe.com/support/SSA-UG• HPE Smart Storage Administrator CLI User Guide https://www.hpe.com/support/SSACLI-UG
HPE MR controller user guides	<ul style="list-style-type: none">• HPE MR Gen11 Controller User Guide https://hpe.com/support/MR-Gen11-UG<ul style="list-style-type: none">◦ MR Gen11 controller configuration: https://www.hpe.com/support/MR-Gen11-configuration◦ MR Gen11 controller RAID creation: https://www.hpe.com/support/MR-Gen11-RAID-creation
HPE MR controller configuration guides	<ul style="list-style-type: none">• HPE MR Storage Administrator User Guide https://www.hpe.com/support/MRSA• HPE StorCLI User Guide https://www.hpe.com/support/StorCLI• HPE StorCLI2 User Guide https://www.hpe.com/support/StorCLI2
Intel VROC for HPE Gen11	<ul style="list-style-type: none">• Intel Virtual RAID on CPU for HPE User Guide https://hpe.com/support/VROC-Gen11-UG• Intel VROC SATA RAID quick installation: https://www.hpe.com/support/VROC-SATA-RAID-installation <p>OS-specific configuration guides:</p> <ul style="list-style-type: none">• Intel Virtual RAID on CPU (Intel VROC) for Windows User Guide

Controller type	Documentation
	<p>https://docs.graidtech.com/vroc/User_Guides/000094004_Intel_Virtual_RAID_on_CPU_Intel_VROC_User_Guide_for_Windows/</p> <ul style="list-style-type: none"> Intel Virtual RAID on CPU (Intel VROC) for Linux User Guide <p>https://docs.graidtech.com/vroc/User_Guides/000094694_Intel_Virtual_RAID_on_CPU_Intel_VROC_User_Guide_for_Linux/</p> <ul style="list-style-type: none"> Intel Volume Management Device Driver for VMware ESXi User Guide <p>https://docs.graidtech.com/vroc/User_Guides/000094787_Intel_Virtual_RAID_on_CPU_Intel_VROC_User_Guide_for_VMware_ESXi/</p>
Storage controller documents library	https://www.hpe.com/support/hpestoragecontrollerdocs-quicklinks

Deploying an OS

For a list of supported operating systems, see the HPE Servers Support & Certification Matrices:

<https://www.hpe.com/support/Servers-Certification-Matrices>

To	See
Deploy an OS using HPE Compute Ops Management	<p>HPE Compute Ops Management User Guide</p> <p>https://www.hpe.com/support/hpe-gl-com-quicklinks</p>
Deploy an OS using Intelligent Provisioning	<p>Intelligent Provisioning user guide</p> <p>https://www.hpe.com/support/hpeintelligentprovisioning-quicklinks</p>
Deploy an OS using iLO virtual media	iLO user guide

To	See
	https://www.hpe.com/support/hpeilodocs-quicklinks
Configure the server to boot from a PXE server	UEFI System Utilities User Guide for HPE ProLiant Gen11 Servers and HPE Synergy https://www.hpe.com/support/UEFIGen11-UG-en
Configure the server to boot from a SAN	HPE Boot from SAN Configuration Guide https://www.hpe.com/info/boot-from-san-config-guide

Configuring security

To	See
Implement server security best practices.	<ul style="list-style-type: none"> HPE Compute Security Reference Guide https://www.hpe.com/info/server-security-reference-en HPE iLO 6 Security Technology Brief https://www.hpe.com/support/ilo6-security-en
Configure and use the Server Configuration Lock feature on HPE Trusted Supply Chain servers and other servers that have the Server Configuration Lock feature enabled.	Server Configuration Lock User Guide for HPE ProLiant servers and HPE Synergy https://www.hpe.com/info/server-config-lock-UG-en

Server management

To monitor	See
Single server	HPE iLO https://www.hpe.com/support/hpeilodocs-quicklinks
Multiple servers	HPE OneView https://www.hpe.com/support/hpeoneview-quicklinks
Single or multiple servers	HPE Compute Ops Management https://www.hpe.com/support/hpe-gl-com-quicklinks

Managing Linux-based high performance compute clusters

To	Use
Provision, manage, and monitor clusters.	HPE Performance Cluster Manager https://www.hpe.com/support/hpcm_manuals
Optimize your applications.	HPE Performance Analysis Tools https://www.hpe.com/info/perftools
Optimize software library for low latency and high bandwidth, both on-node and off-node, for point-to-point and collective communications.	HPE Cray Programming Environment User Guide https://www.hpe.com/info/cray-pe-user-guides

Cabling

This chapter includes cabling guidelines and diagrams for internal component cabling.

Subtopics

Cabling guidelines
Internal cabling management
Cabling diagrams
Storage cabling
Accelerator cabling
HPE NS204i Boot Device cabling
Switch board cabling
Optical drive cabling
Display port cabling
Serial port cabling
Front I/O cabling
VGA cabling
Chassis intrusion detection switch cabling

Cabling guidelines

Observe the following:



NOTE

The colors in the cabling diagrams are for illustration purposes only.



CAUTION

To avoid damaging connectors, avoid repeated installation and removal of cables. Excessive handling can shorten the lifespan of the cable.

- For cable option kits, see the product QuickSpecs.
- For cable spare part numbers, see the Illustrated parts catalog in the maintenance and service guide.
- Some diagrams show alphabetical callouts such as A, B, C, etc. These callouts correspond to labels near the connectors on the cable.
- Some cables have more than one connector, such as a Y-cable, but not all connectors are used.
- Observe all guidelines when working with server cables.

Before connecting cables

- Note the port labels on the PCA components. Not all these components are used by all servers:
 - System board ports
 - Drive and power supply backplane ports

- Expansion board ports (controllers, retimers, adapters, expanders, risers, and similar boards)
- Note the label near each cable connector. This label indicates the destination port for the cable connector.
- Some data cables are prebent. Do not unbend or manipulate the cables.
- To prevent mechanical damage or depositing oil that is present on your hands, and other contamination, do not touch the ends of the connectors.

When connecting cables

- Before connecting a cable to a port, lay the cable in place to verify the length of the cable.
- Use the internal cable management features to properly route and secure the cables.
- Route cables so that they do not contact or rest on cooling components, including heatsinks. Ensure that cable routing does not obstruct airflow to or from heatsinks or ventilation openings
- When routing cables, be sure that the cables are not in a position where they can be pinched or crimped.
- Avoid tight bend radii to prevent damaging the internal wires of a power cord or a server cable. Never bend power cords and server cables tight enough to cause a crease in the sheathing.
- Make sure that the excess length of cables is properly secured to avoid excess bends, interference issues, and airflow restriction.
- Before installing a new component or closing up the server, make sure that all cables are in their appropriate routing position. This cable check prevents component damage and potential signal interference.

When disconnecting cables

- Grip the body of the cable connector. Do not pull on the cable itself because this action can damage the internal wires of the cable or the pins on the port.

- If a cable does not disconnect easily, check for any release latch that must be pressed to disconnect the cable.

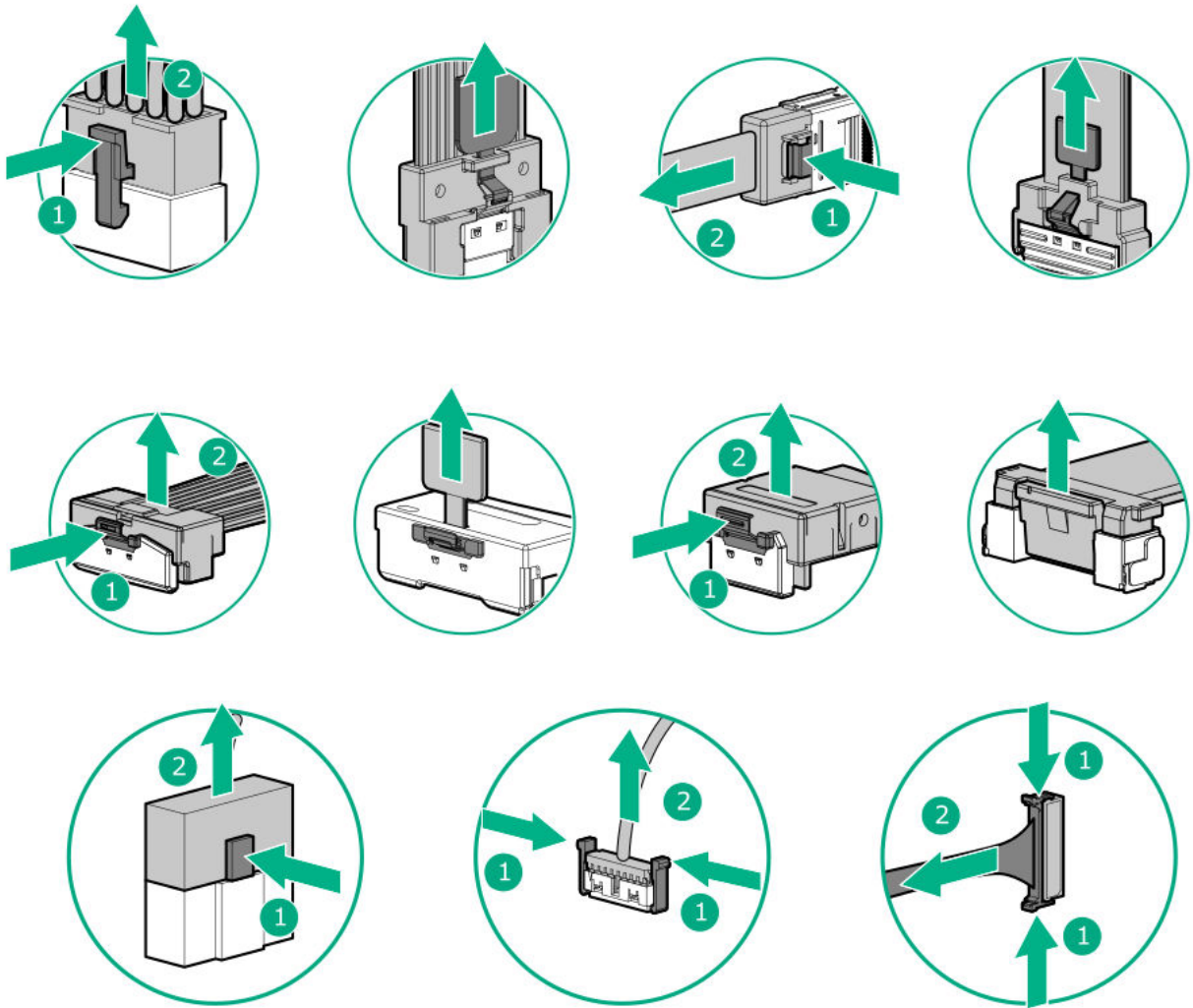

- Remove cables that are no longer being used. Retaining them inside the server can restrict airflow. If you intend to use the removed cables later, label and store them for future use.

Internal cabling management

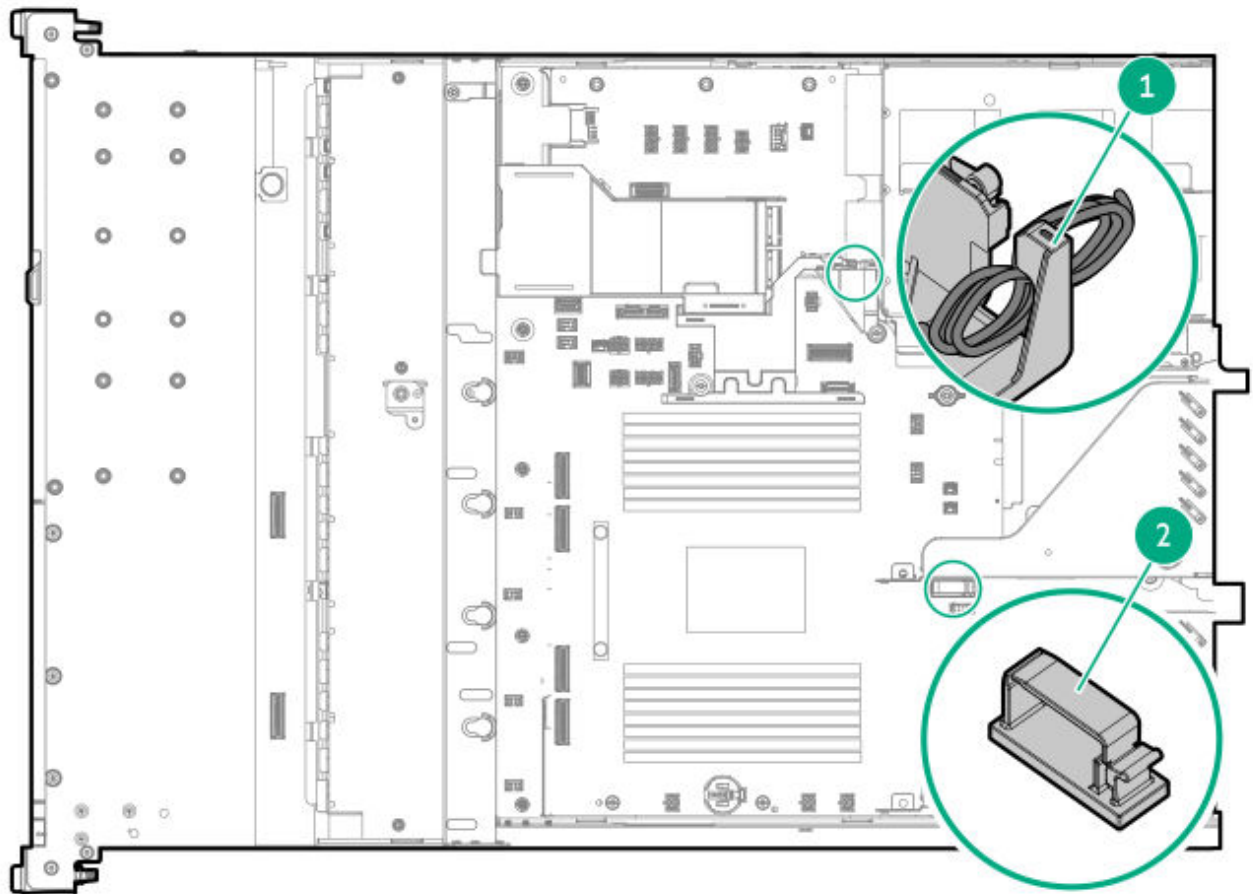

Item	Description
1	Cable organizer
2	Cable clip

Cabling diagrams

Observe the following:

- Before cabling components, see the [Cabling guidelines](#).
- Use the cable part number or search feature to find your diagram.

Component cabling	Cable part number
Drive power cabling	
2 SFF drive power cabling	P64313-001
8+2 SFF drive power cabling	869667-001
4 SFF drive power cabling	P54942-001
8 SFF drive power cabling	P53958-001
8 E3.S drive power cabling	P54939-001
4 LFF drive power cabling	P53988-001
10/12 LFF drive power cabling	<ul style="list-style-type: none"> • P54925-001 • P54926-001 • P54927-001
2 SFF drive controller cabling	
2 SFF drive: Onboard SATA cabling	P53969-001
2 SFF drive: Onboard NVMe cabling	P53967-001
2 SFF drive: Re-timer card cabling	P53984-001
4 SFF drive controller cabling	
4 SFF drive: Secondary type-p controller cabling	P45610-001
4 E3.S drive controller cabling	
4 E3.S drive: Onboard NVMe cabling	P53960-001
8 SFF drive controller cabling	
8 SFF drive: Onboard SAS/SATA cabling	P53957-001
8 SFF drive: Onboard NVMe cabling	<ul style="list-style-type: none"> • P53959-001 • P53960-001 • P53961-001 • P53967-001
8 SFF drive: Primary type-p controller cabling	<ul style="list-style-type: none"> • P53977-001 • P53978-001 • P45611-001 • P53972-001 • P53976-001
8 SFF drive: Secondary type-p controller cabling	P64312-001
8 SFF drive: Type-o controller cabling	<ul style="list-style-type: none"> • P53979-001

Component cabling	Cable part number
	<ul style="list-style-type: none"> • P48964-001
8 + 2 SFF drive: Type-o controller cabling	P48960-001
8 E3.S drive controller cabling	
8 E3.S drive: Type-p controller cabling	P54940-001
8 E3.S drive: SR932i-p controller cabling	P62296-001
4 LFF drive controller cabling	
4 LFF drive: Onboard SATA cabling	P53989-001
4 LFF drive: Type-o controller cabling	P53989-001
10 LFF and 12 LFF drive controller cabling	
10 LFF drive: Onboard SAS/SATA cabling	<ul style="list-style-type: none"> • P54928-001 • P54929-001
12 LFF: Secondary type-p controller cabling	<ul style="list-style-type: none"> • P54930-001 • P54931-001
Accelerator cabling	
GPU auxiliary power cabling	<ul style="list-style-type: none"> • P60495-001 • P61488-001 • P61487-001 • P61489-001 • P68828-001 • P68829-001
GPU riser power cabling	<ul style="list-style-type: none"> • P60489-001 • P60490-001
GPU riser signal cabling	P51471-001
GPU riser power cabling to the switch board	<ul style="list-style-type: none"> • P60494-001 • P60493-001
GPU riser signal cabling to the switch board	<ul style="list-style-type: none"> • P44002-001 • P55910-001
HPE NS204i Boot Device cabling: Option 1	<ul style="list-style-type: none"> • P54088-001 • P54087-001
HPE NS204i Boot Device cabling: Option 2	<ul style="list-style-type: none"> • P54088-001

Component cabling	Cable part number
	• P56364-001
Switch board cabling	
Power cabling	P60491-001
Signal cabling	P60492-001
Sideband cabling	P54897-001
Optical drive cabling	
8 SFF drive: Optical drive cabling	P45622-001
4 LFF drive: Optical drive cabling	P45622-001
Display port cabling	
8 SFF drive: Display port cabling	P45620-001
4 LFF drive: Display port cabling	P45619-001
Front I/O cabling	
8 SFF drive and 4 LFF drive: Front I/O cabling	P43727-001
12 LFF drive: Front I/O cabling	P54923-001
GPU dense: Front I/O cabling	P47750-001
Miscellaneous cabling	
Storage controller backup cabling	877849-001
Energy pack cabling	P01366-B21
Serial port cabling	P47752-001
VGA cabling	P53987-001
Chassis intrusion detection switch cabling	869413-001

Storage cabling

Subtopics

[Drive power cabling](#)

[Storage controller cabling](#)

[Energy pack cabling](#)

[Storage controller backup cabling](#)

Drive power cabling

2 SFF drive power cabling

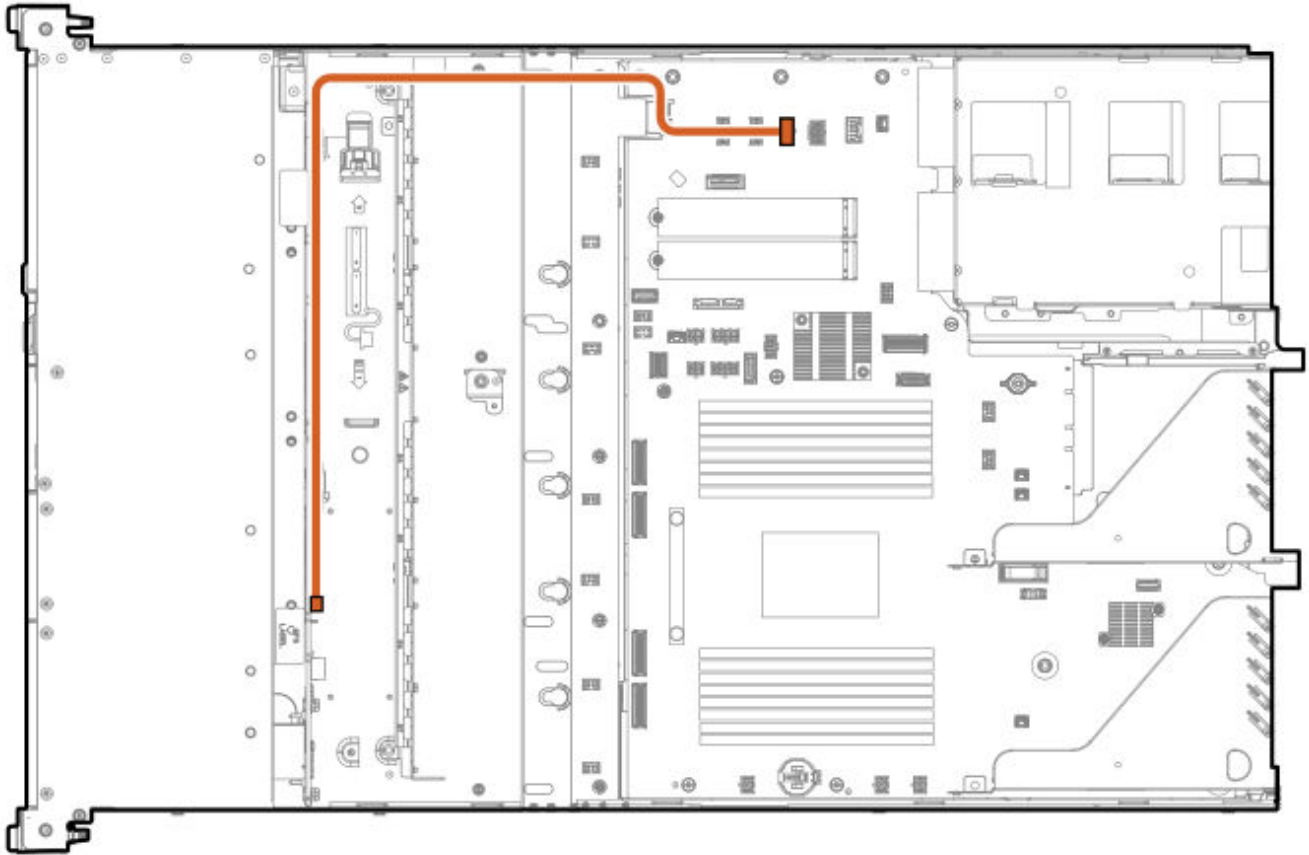

Cable part number	Color	From	To
P64313-001	Orange	Drive box 1 power connector	2 SFF drive power connector

8+2 SFF drive power cabling

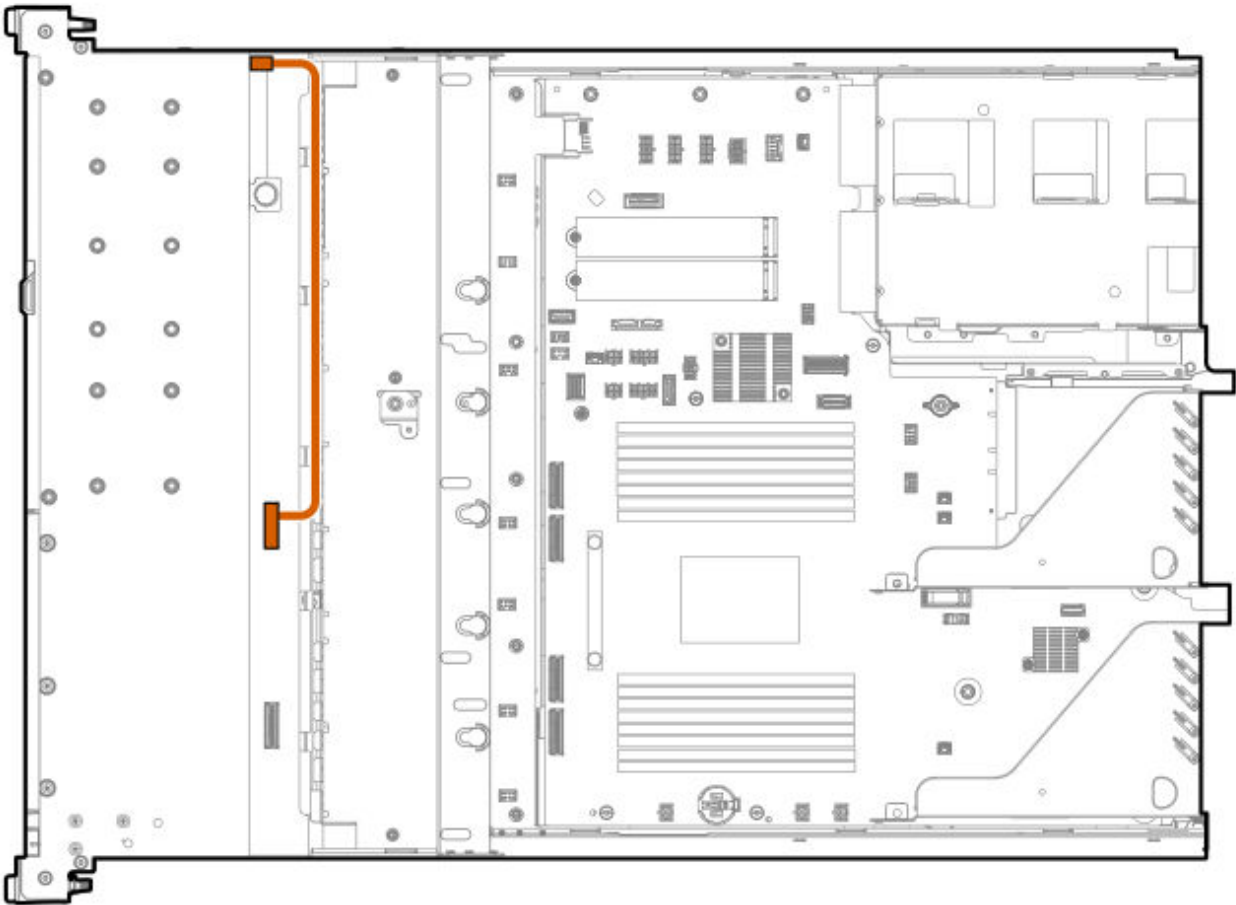

Cable part number	Color	From	To
869667-001 ¹ / _—	Orange	2 SFF drive power connector	8 SFF drive power connector

¹/_— Option kit: P52749-B21; P52751-B21

4 SFF drive power cabling

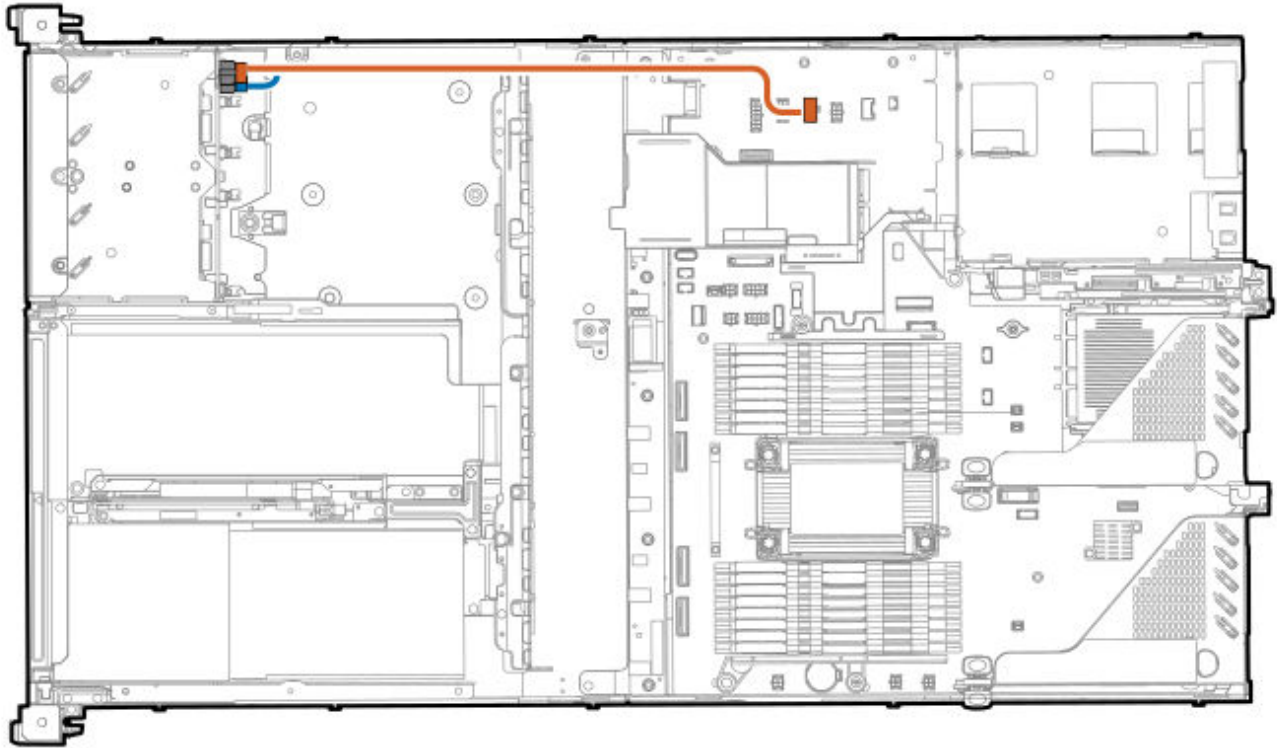

Cable part number	Color	From	To
P54942-001 ¹ / _—	Orange	Drive box power connector 1	Top backplane port 1
	Blue	Drive box power connector 1	Bottom backplane port 1

¹/_— Option kit: P61220-B21; P61221-B21

8 SFF drive power cabling

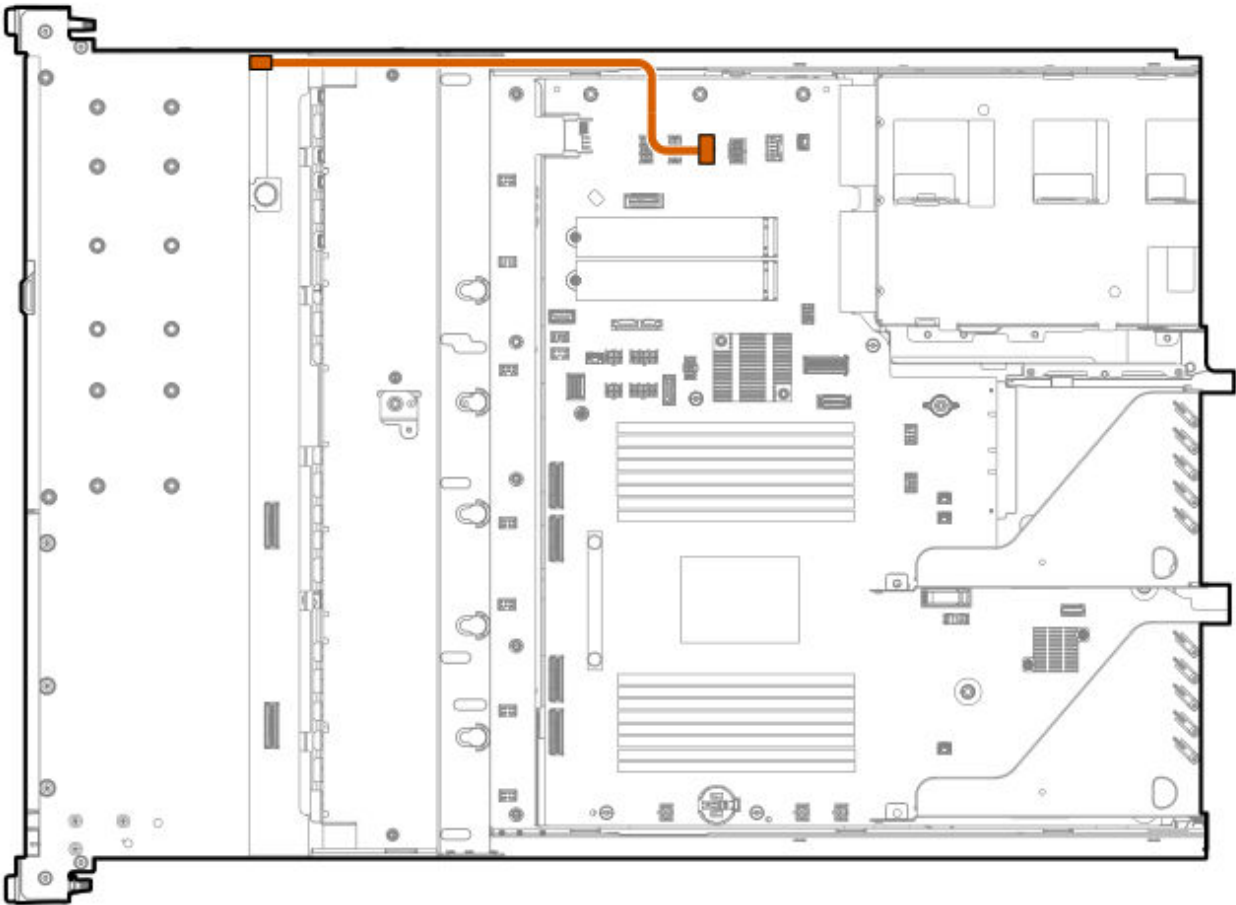

Cable part number	Color	From	To
P53958-001 ¹ / _—	Orange	Drive box 1 power connector	Box 1 power connector

¹/_— Option kit: P52743-B21; P52745-B21; P52747-B21

8 E3.S drive power cabling

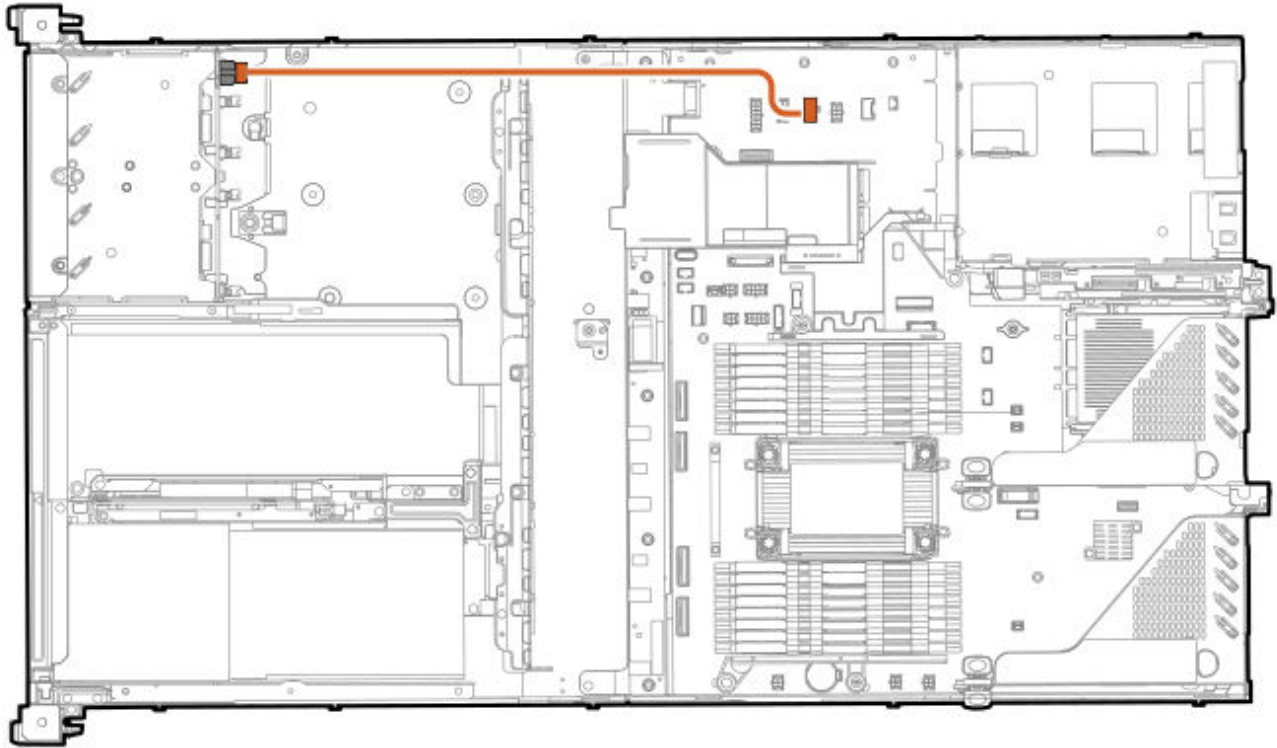

Cable part number	Color	From	To
P54939-001 ¹ / _—	Orange	Drive box 1 power connector	Port 1

¹/_— Option kit: P61219-B21

4 LFF drive power cabling

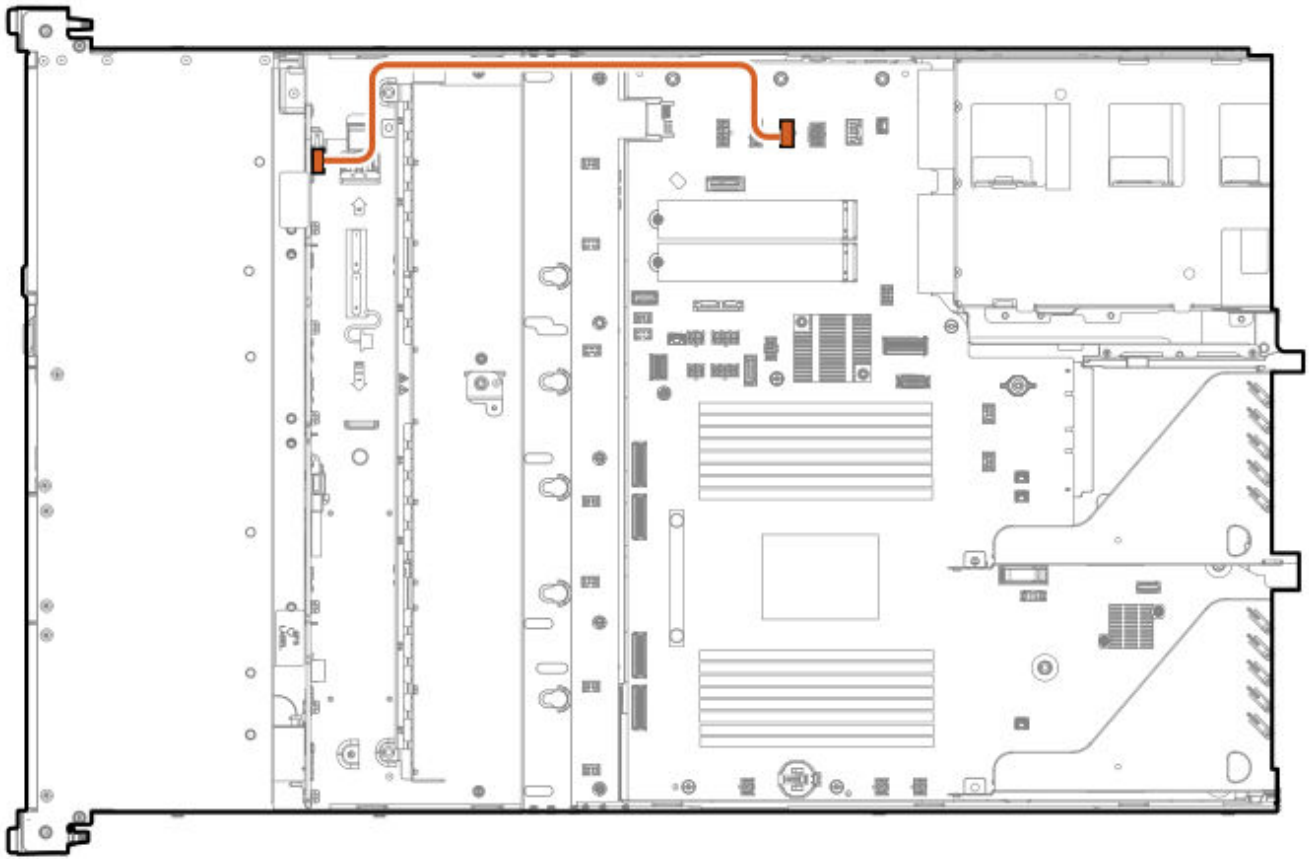

Cable part number	Color	From	To
P53988-001	Orange	Drive box 1 power connector	4 LFF drive box 1 power connector

10/12 LFF drive power cabling

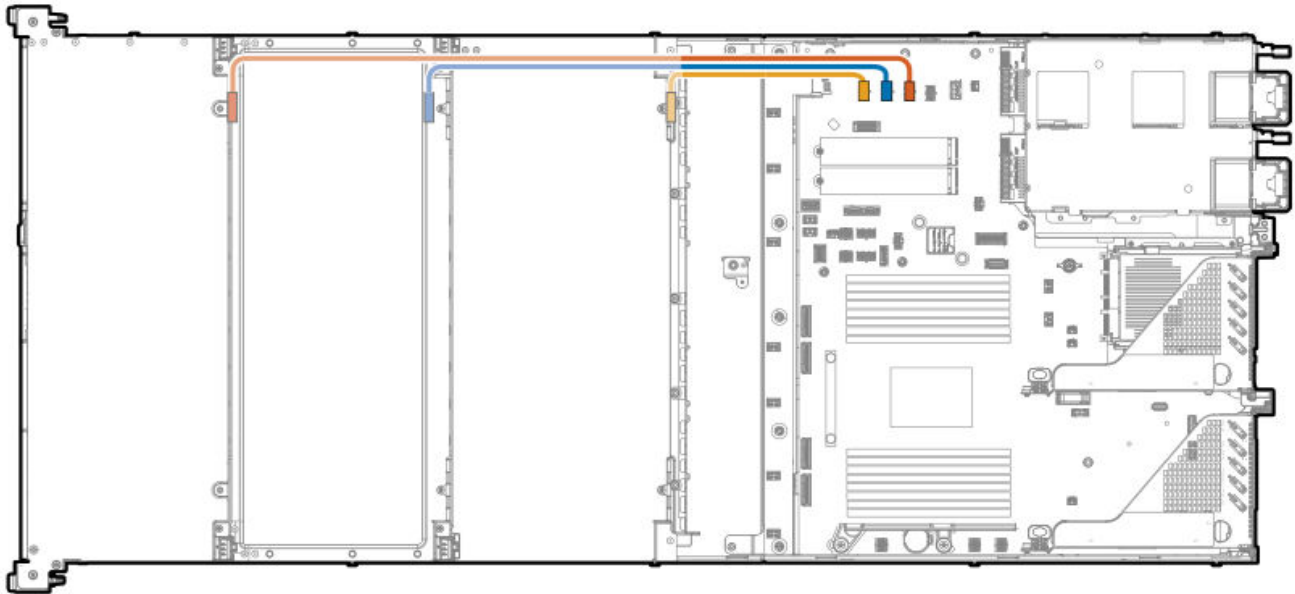

Cable part number	Color	From	To
P54925-001	Orange	Drive box 1 power connector	4 LFF drive box 1 power connector
P54926-001	Blue	Drive box 3 power connector	4 LFF drive box 3 power connector
P54927-001	Yellow	Drive box 5 power connector	4 LFF drive box 5 power connector

Storage controller cabling

Subtopics

- [2 SFF drive controller cabling](#)
- [4 SFF drive controller cabling](#)
- [4 E3.S drive controller cabling](#)
- [8 E3.S drive controller cabling](#)
- [8 SFF drive controller cabling](#)
- [4 LFF drive controller cabling](#)
- [10 LFF drive controller cabling](#)

2 SFF drive controller cabling

2 SFF drive: Onboard SATA cabling

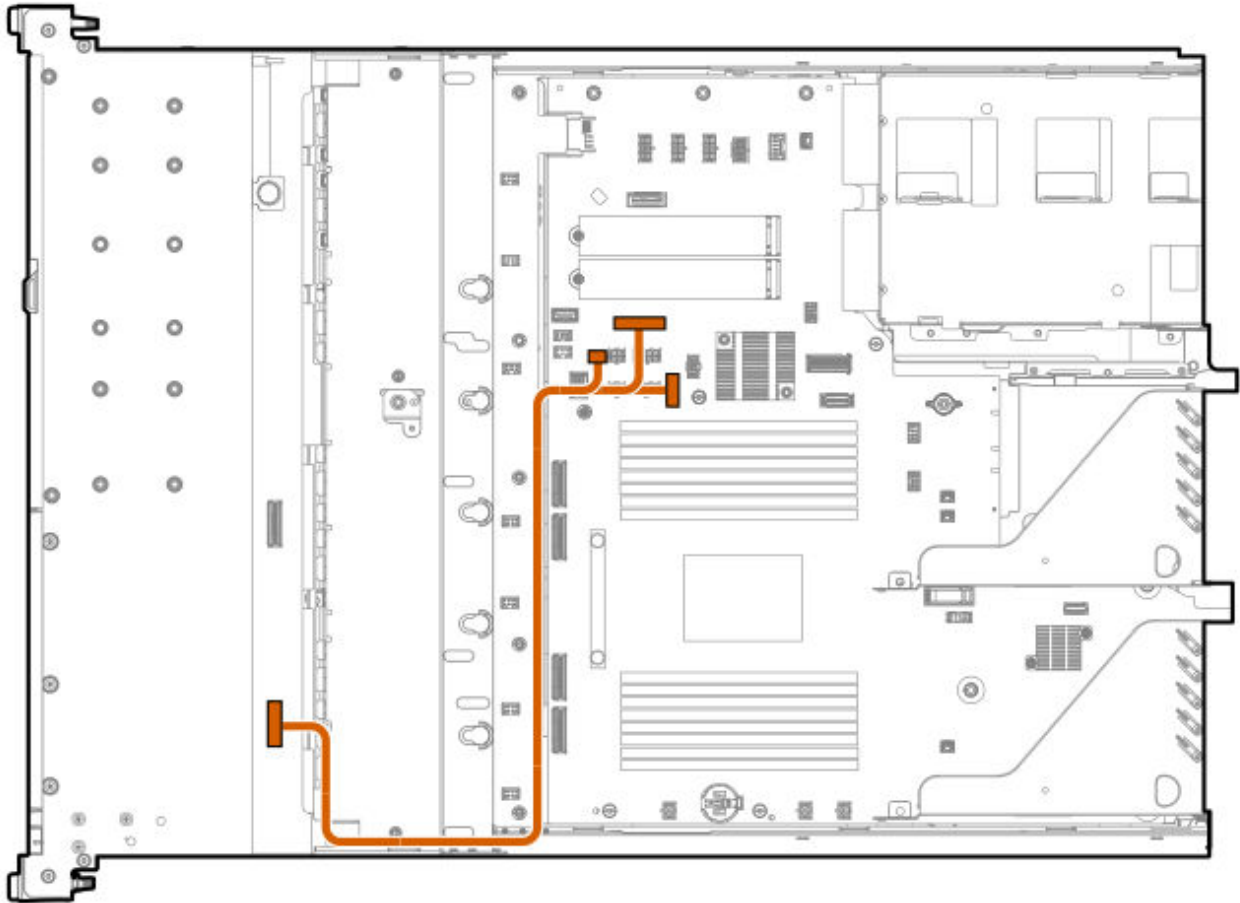

Cable part number	Color	From	To
P53969-001	Orange	2 SFF drive backplane	SATA sideband connector and Optical drive power connector and SATA 6 G b/s port

2 SFF drive: Onboard NVMe cabling

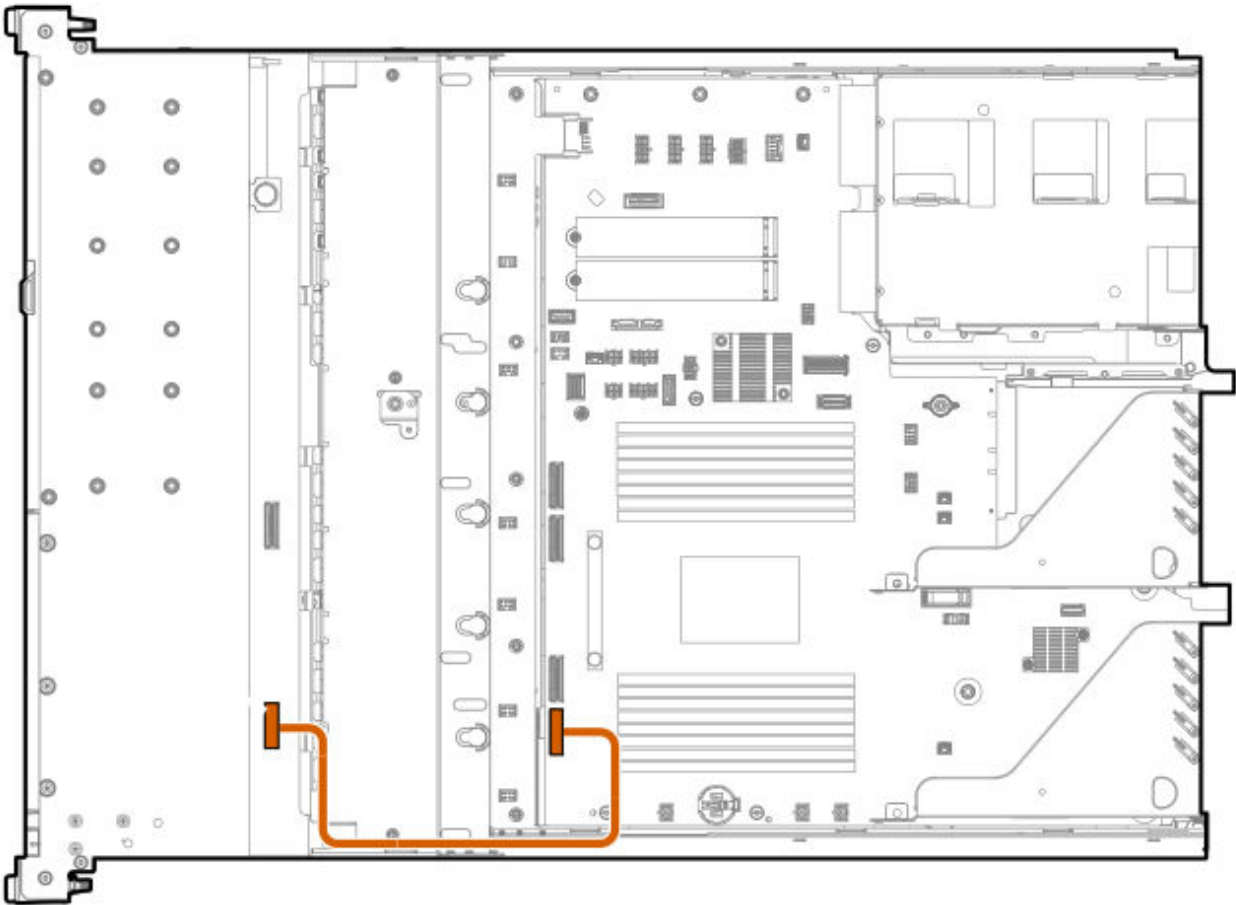

Cable part number	Color	From	To
P53967-001	Orange	2 SFF drive backplane	MCI0 port 1

2 SFF drive: Re-timer card cabling

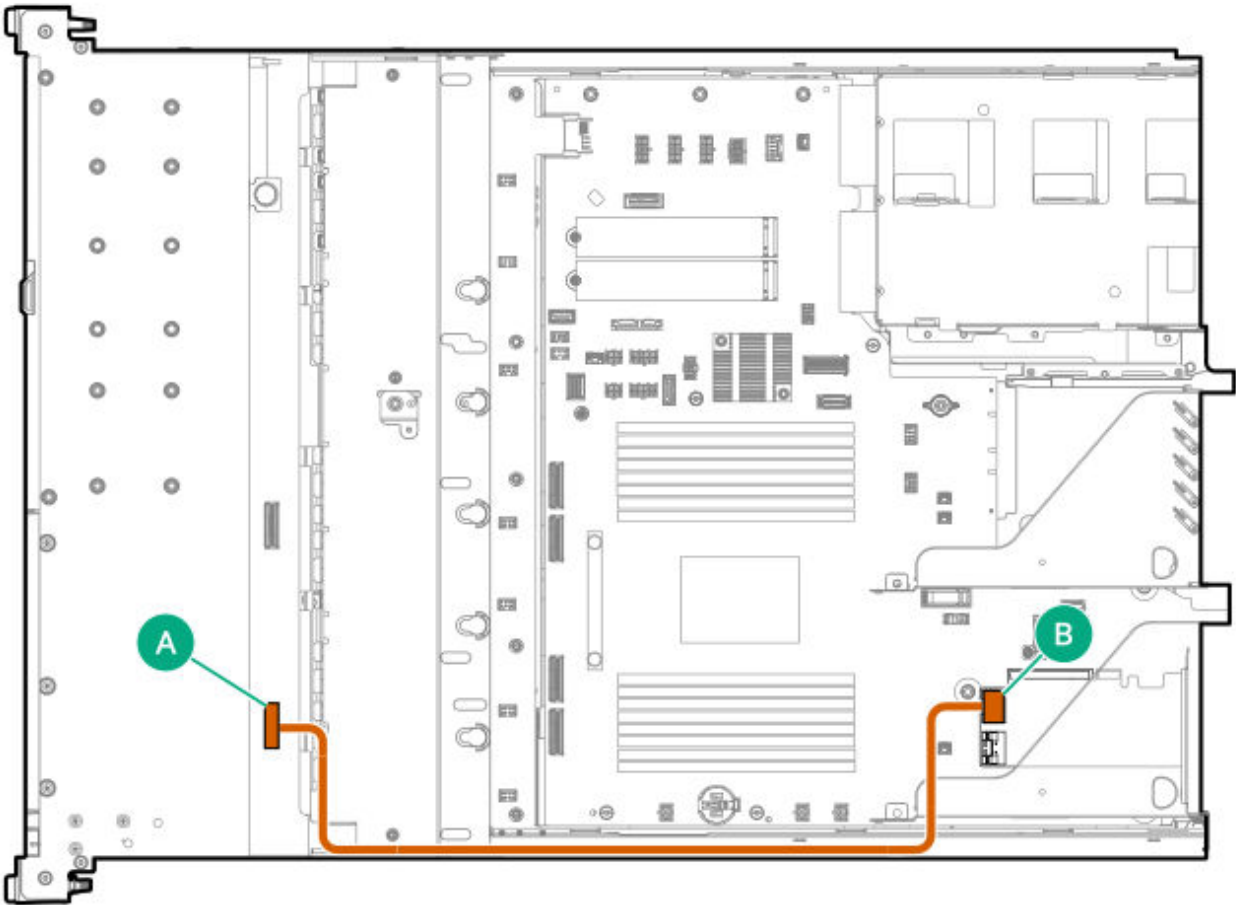

Cable part number	Color	From	To
P53984-001	Orange	2 SFF drive backplane	Port 1

4 SFF drive controller cabling

4 SFF drive: Onboard NVMe cabling

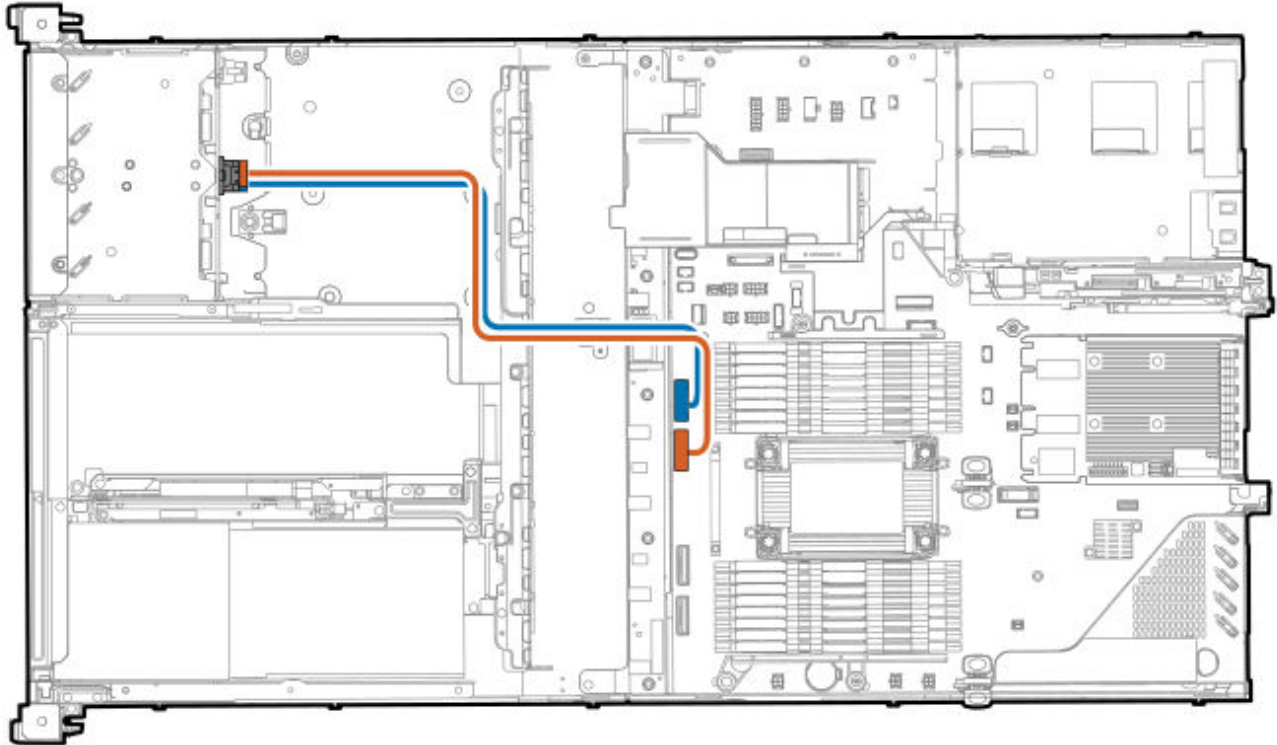

Cable part number	Color	From	To
P53960-001 ¹ ₁	Orange	Top backplane port 1	MCI0 port 3
	Blue	Bottom backplane port 1	MCI0 port 4

¹ ₁ Option kit: P62181-B21

4 SFF drive: Secondary type-p controller cabling

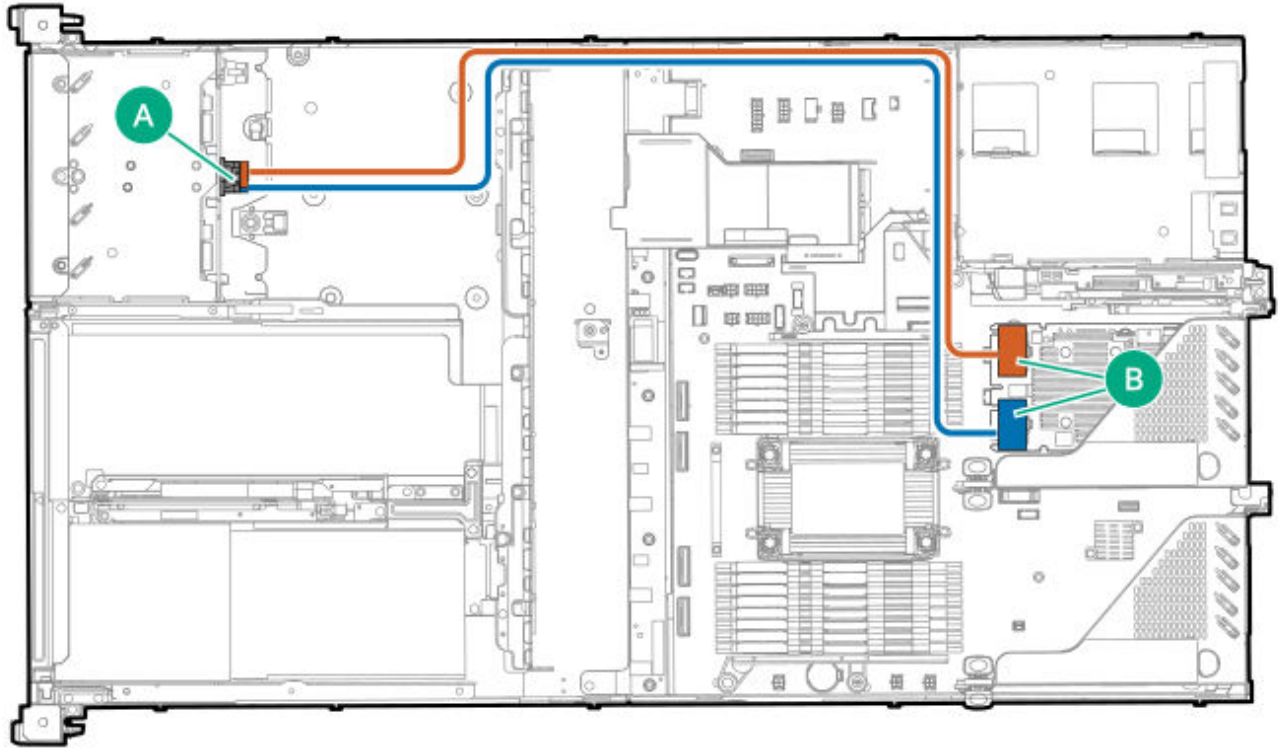

Cable part number	Color	From	To
P45610-001 ¹ / _—	Orange	Top backplane port 1	Port 1
	Blue	Bottom backplane port 1	Port 2

¹/_— Option kit: P62189-B21

4 E3.S drive controller cabling

4 E3.S drive: Onboard NVMe cabling

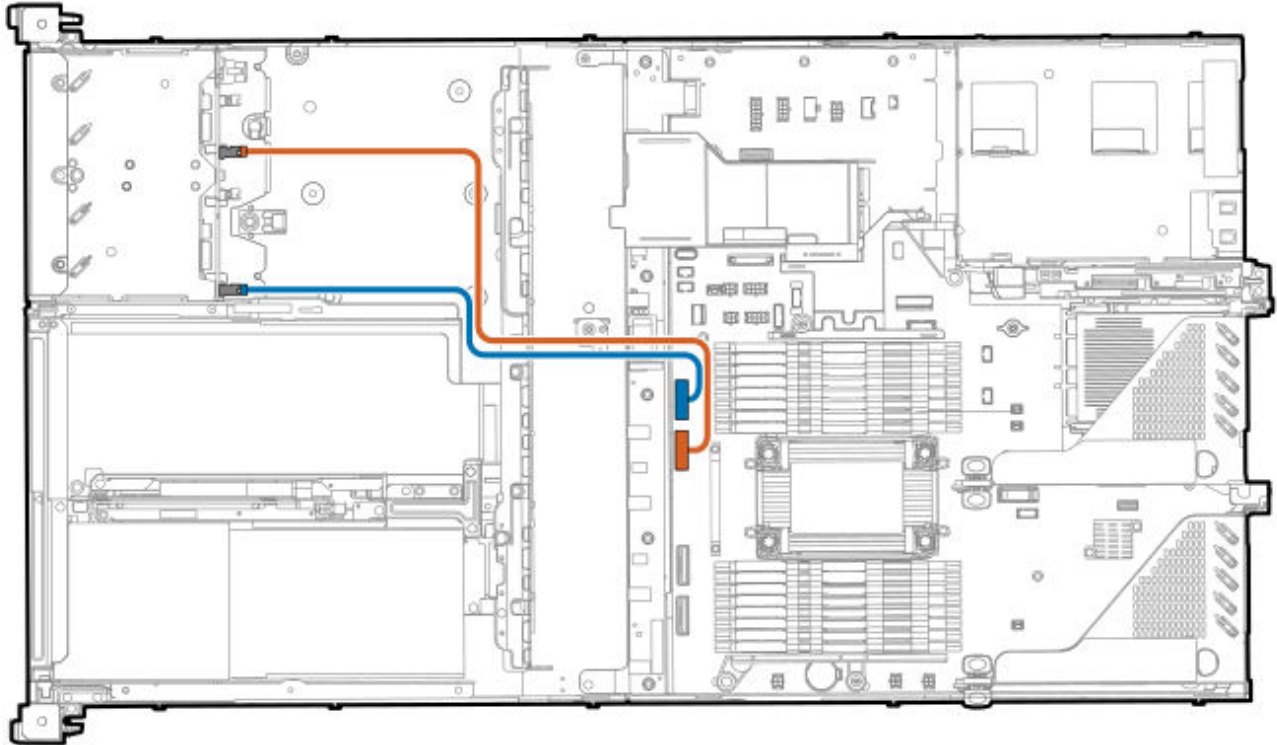

Cable part number	Color	From	To
P53960-001	Orange	Port 2	MCI0 port 3
	Blue	Port 4	MCI0 port 4

8 E3.S drive controller cabling

8 E3.S drive: Type-p controller cabling

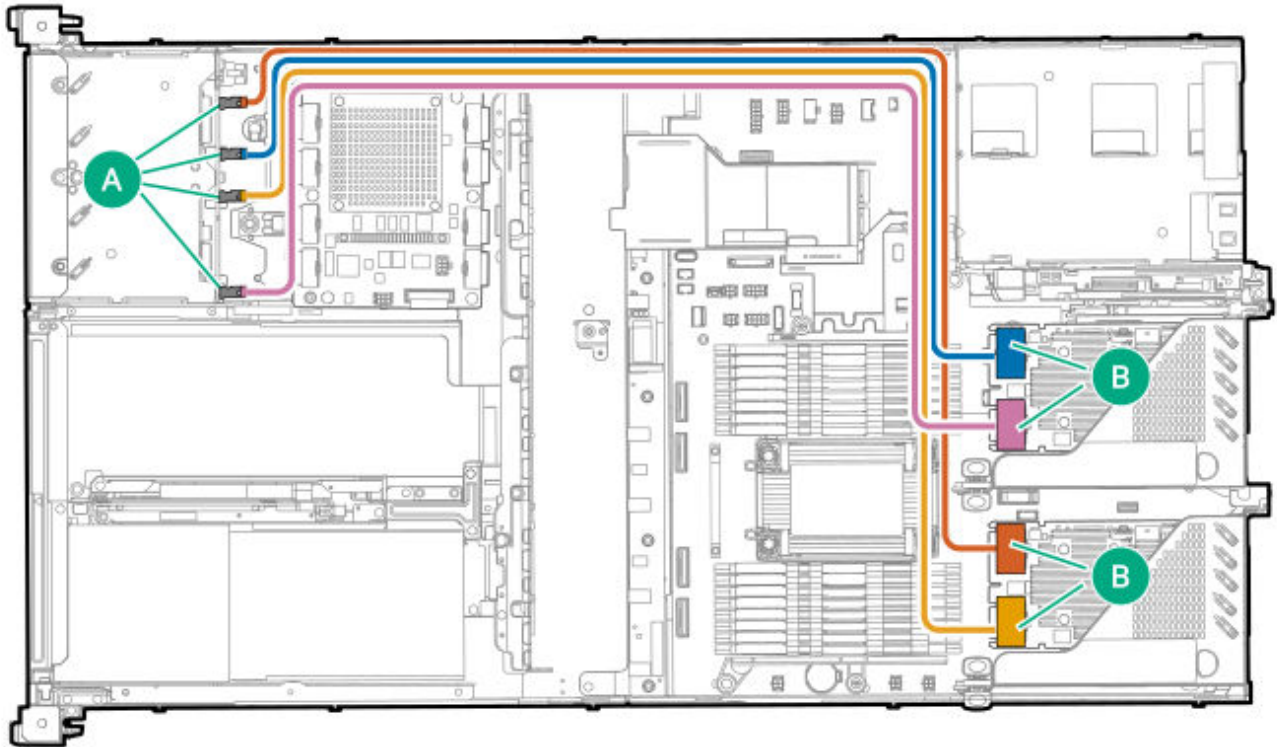

Cable part number	Color	From	To
P54940-001 ¹ / _—	Orange	Port 1	Port 1
	Blue	Port 2	Port 1
	Yellow	Port 3	Port 2
	Pink	Port 4	Port 2

¹/_— Option kit: P62183-B21

8 E3.S drive: SR932i-p controller cabling

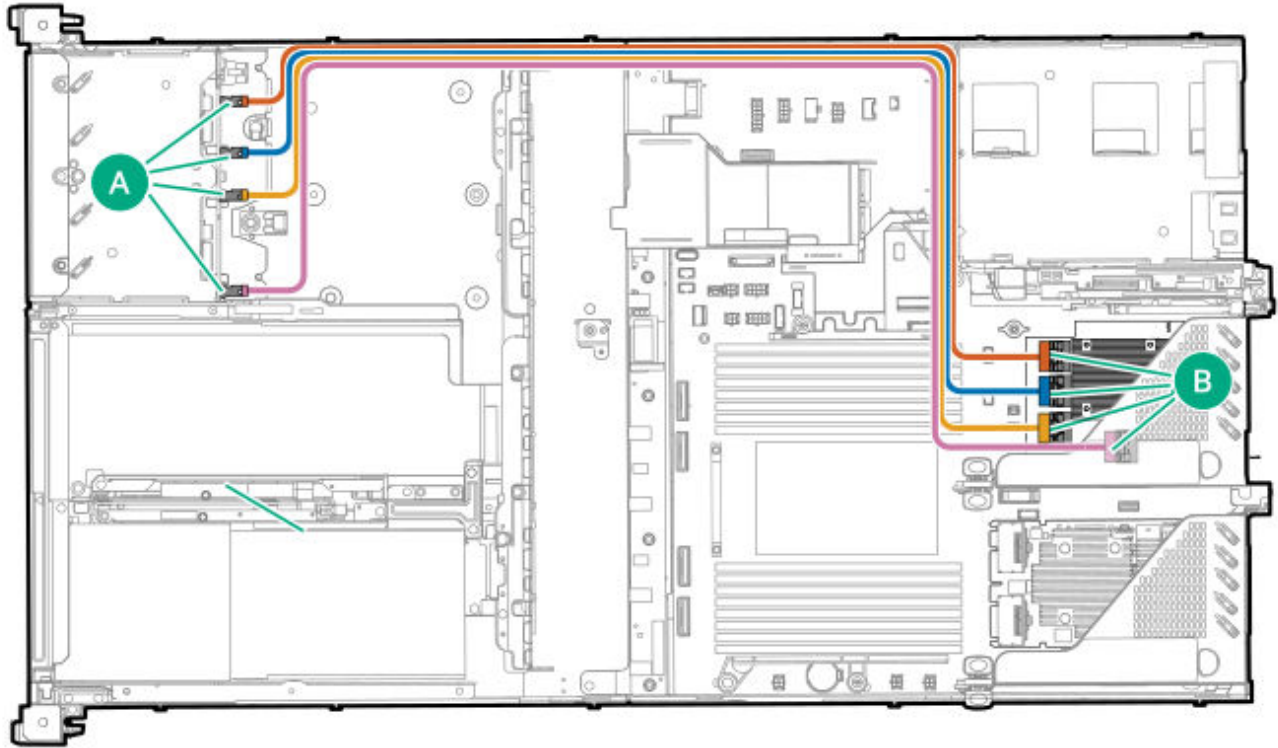

Cable part number	Color	From	To
P62296-001 ¹ / _—	Orange	Port 1	Port 1
	Blue	Port 2	Port 2
	Yellow	Port 3	Port 3
	Pink	Port 4	Port 4

¹/_— Option kit: P62185-B21

8 SFF drive controller cabling

8 SFF drive: Onboard SAS/SATA cabling

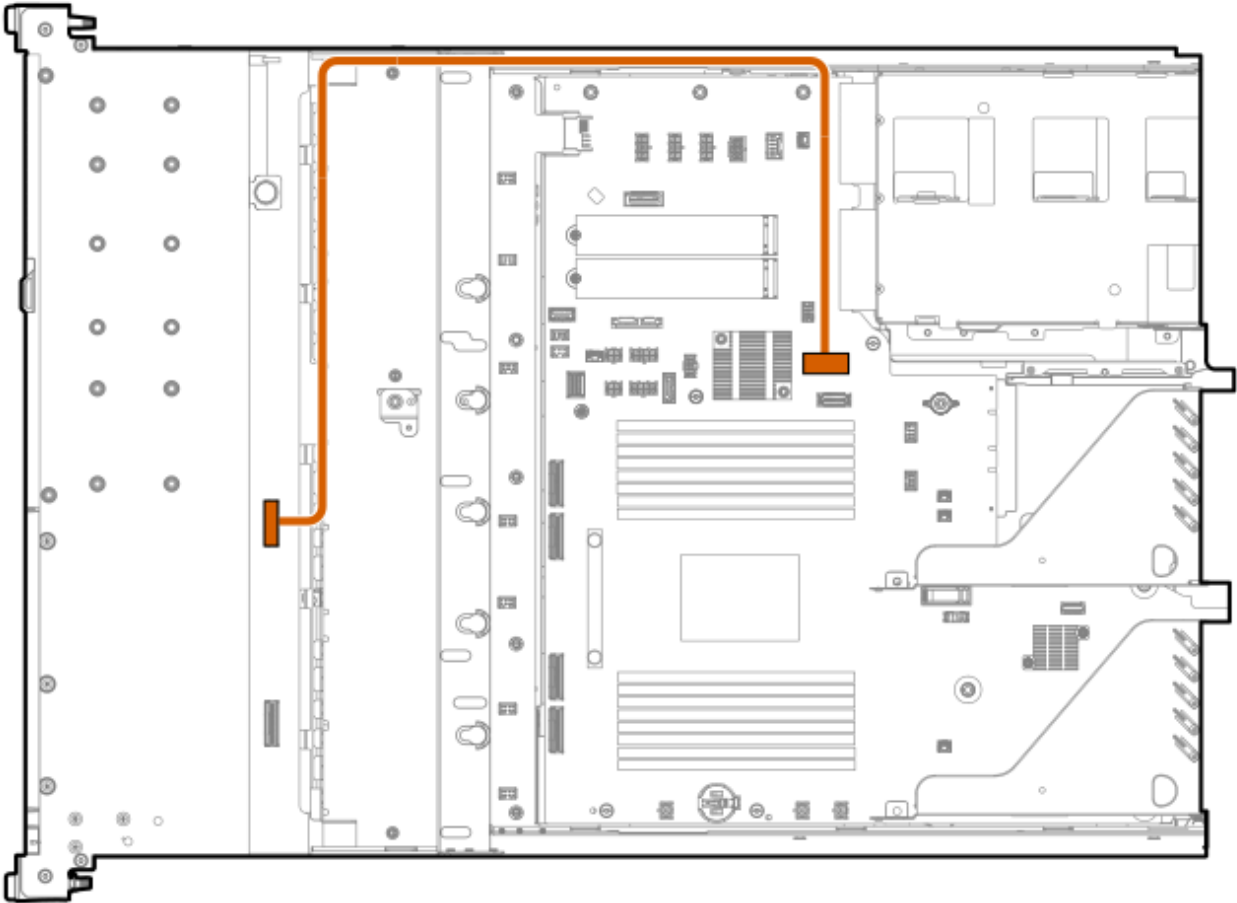

Cable part number	Color	From	To
P53957-001	Orange	Port 1	x8 slimSAS port 1

8 SFF drive: Onboard NVMe cabling



Cable part number	Color	From	To
P53959-001	Orange	Port 1	MCIO port 4
P53960-001	Blue	Port 2	MCIO port 3
P53961-001	Yellow	Port 3	MCIO port 2
P53967-001	Pink	Port 4	MCIO port 1

8 SFF drive: Primary type-p controller cabling

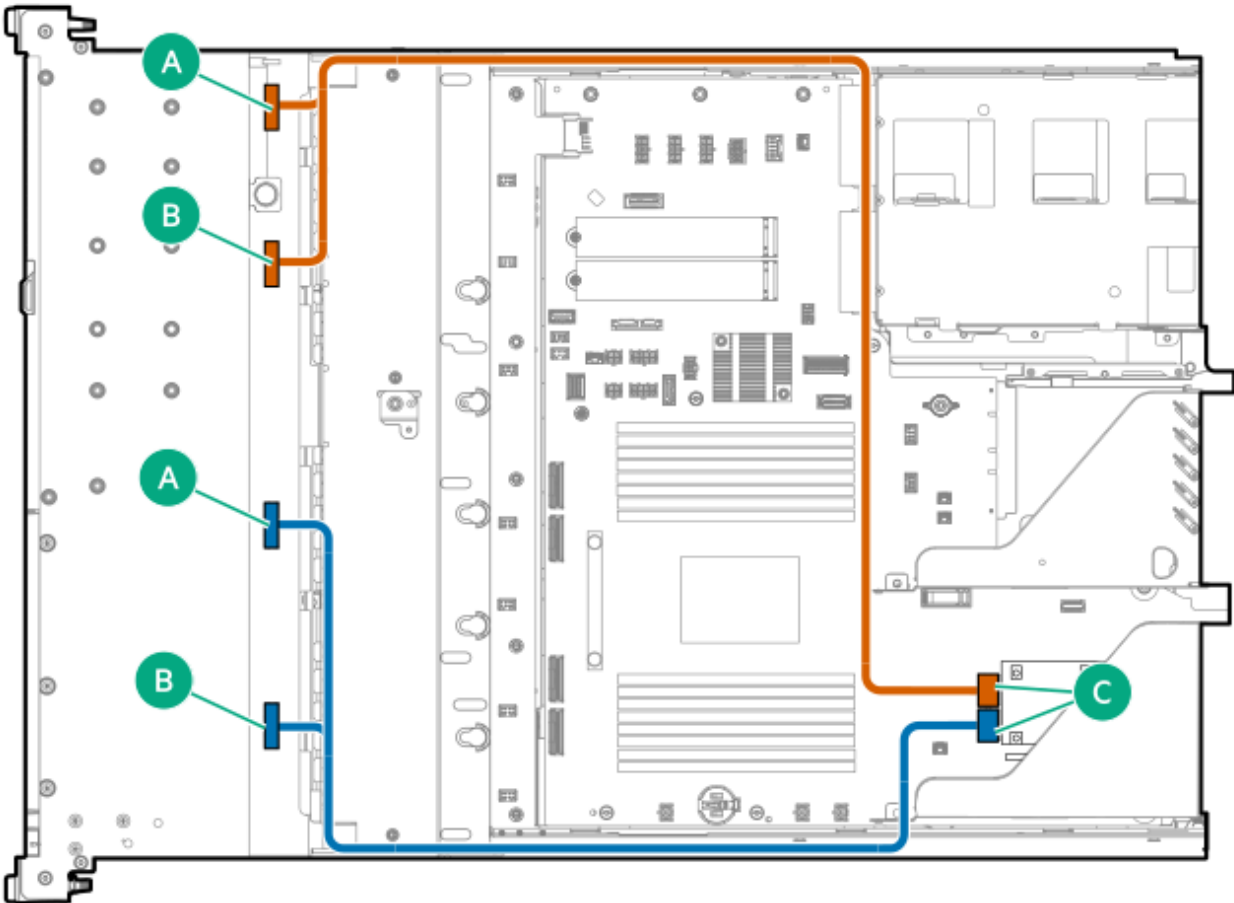

Cable part number	Color	From	To
P53977-001	Orange	Port 1 and port 2	Port 1
P53978-001	Blue	Port 3 and port 4	Port 2

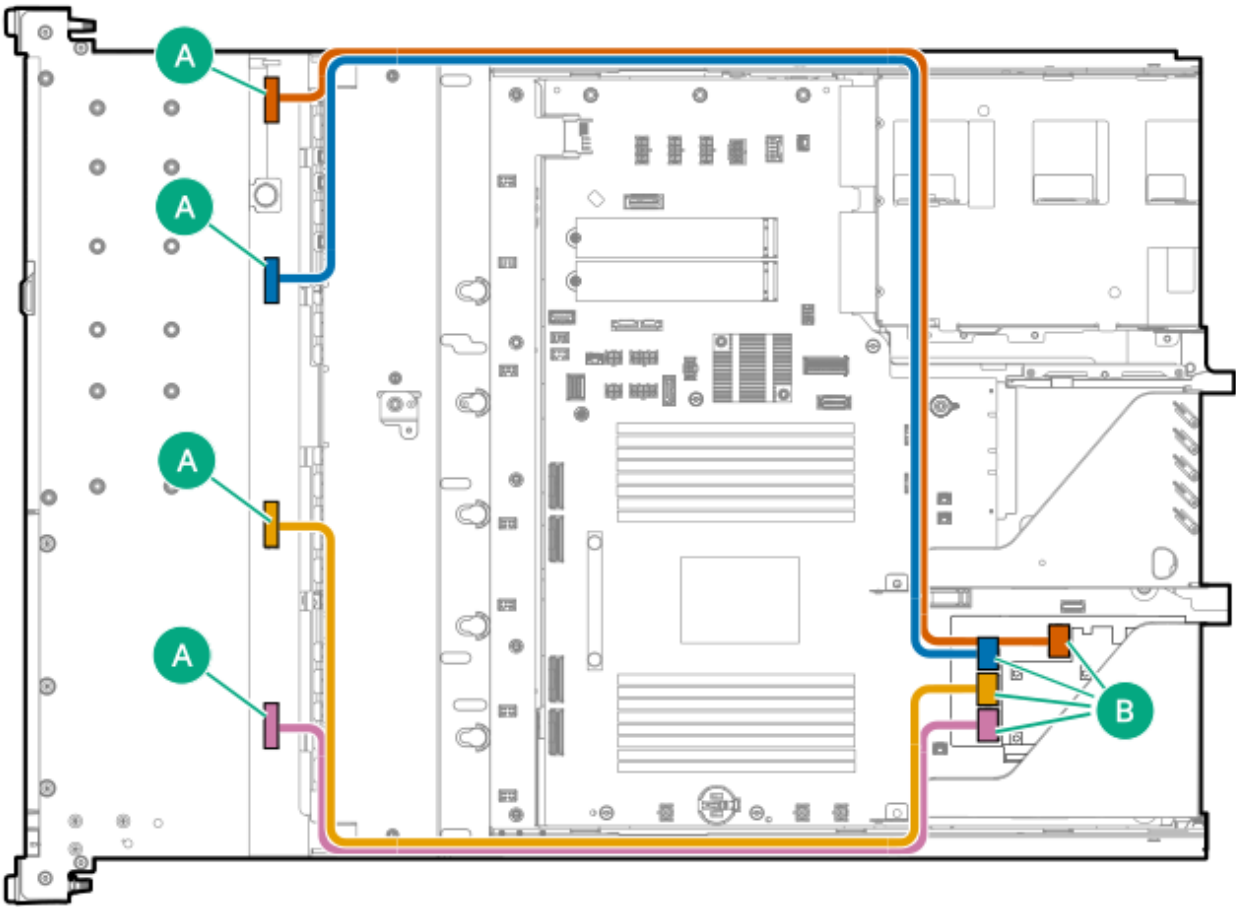

Cable part number	Color	From	To
P45611-001	Orange	Port 1	Port 1
	Blue	Port 2	Port 2
P53972-001	Yellow	Port 3	Port 3
P53976-001	Pink	Port 4	Port 4

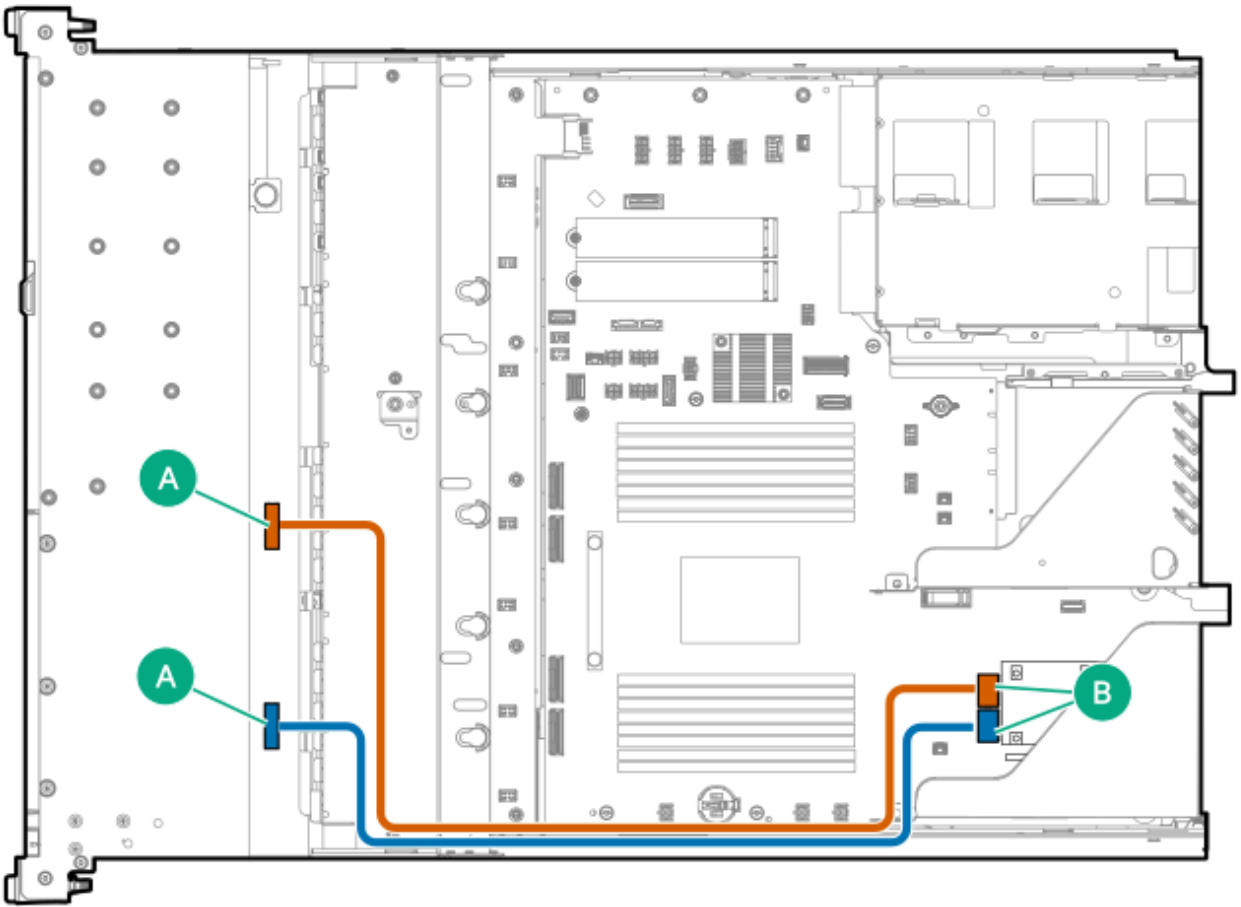

Cable part number	Color	From	To
P53972-001	Orange	Port 3	Port 1
P53976-001	Blue	Port 4	Port 2

8 SFF drive: Secondary type-p controller cabling

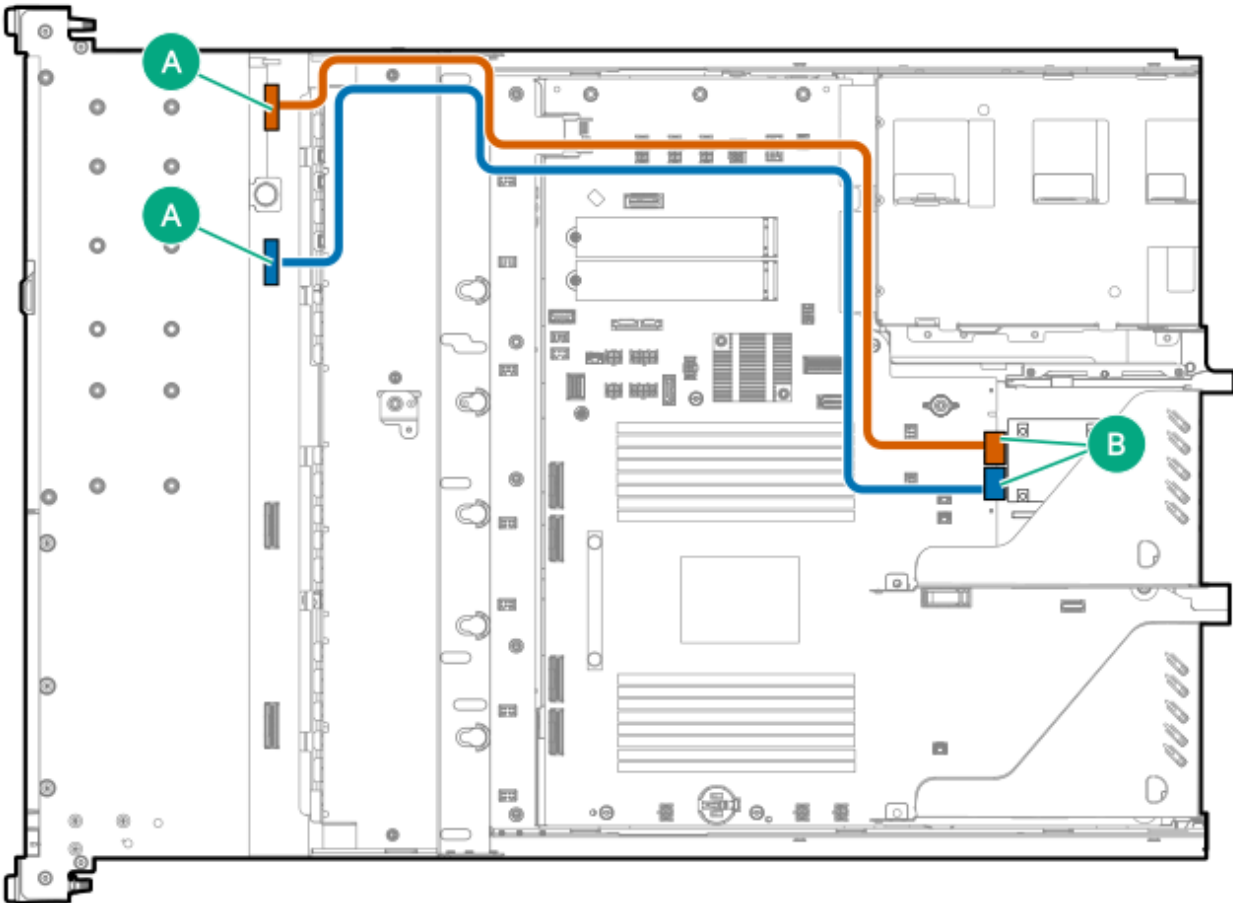

Cable part number	Color	From	To
P64312-001	Orange	Port 1	Port 1
	Blue	Port 2	Port 2

8 SFF drive: Type-o controller cabling

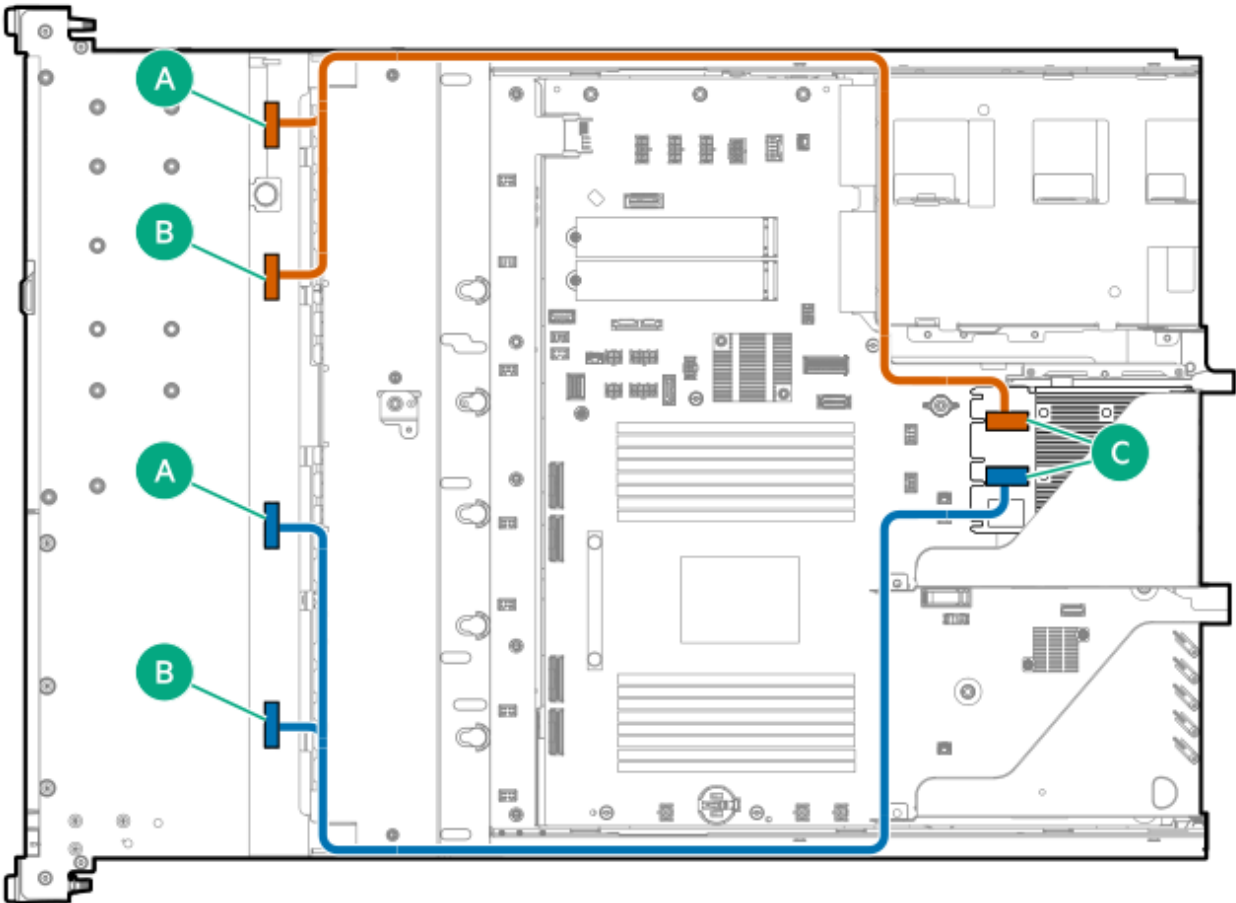

Cable part number	Color	From	To
P53979-001	Orange	Port 1 and port 2	Port 1
P48964-001	Blue	Port 3 and port 4	Port 2

8 + 2 SFF drive: Type-o controller cabling

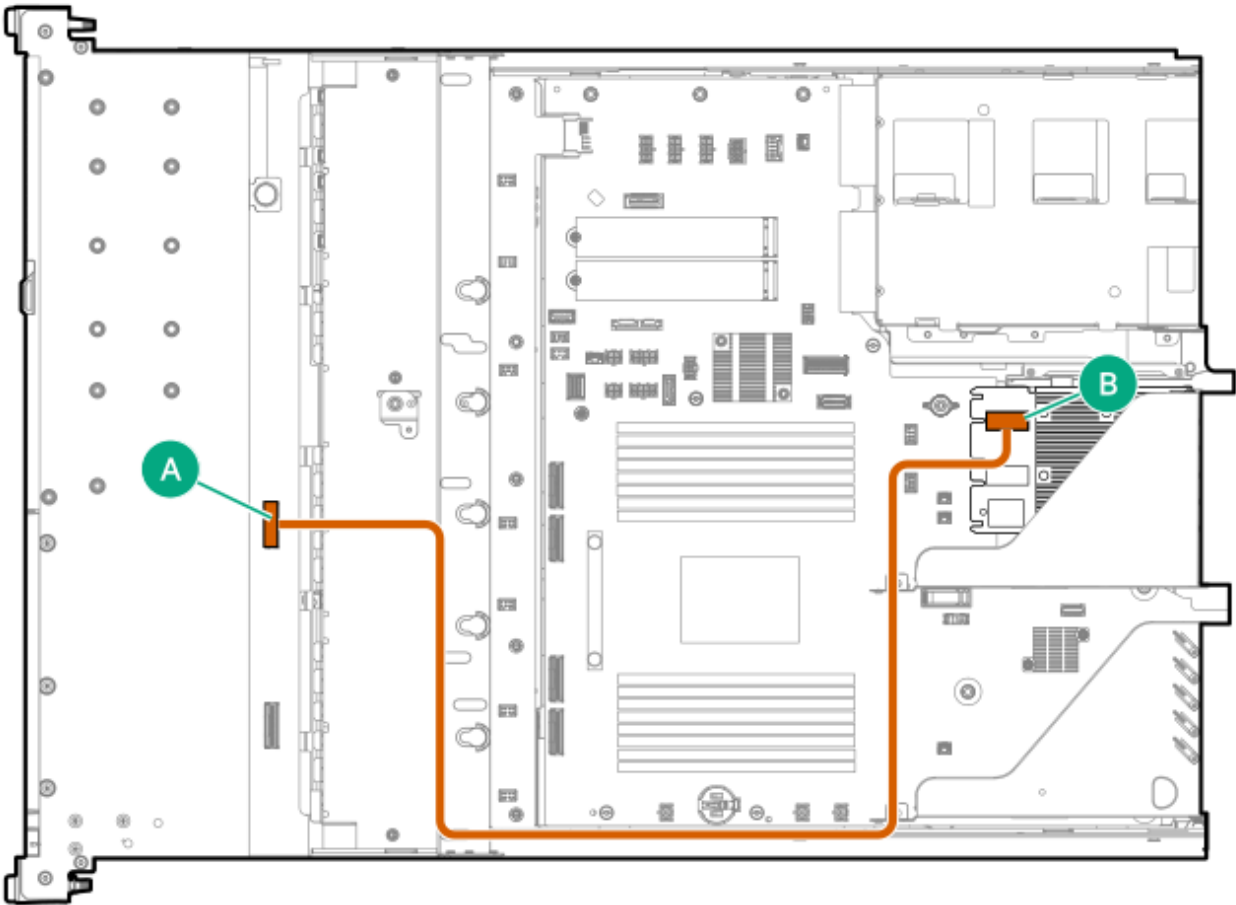

Cable part number	Color	From	To
P48960-001	Orange	8 SFF drive backplane	Type-o controller port 1

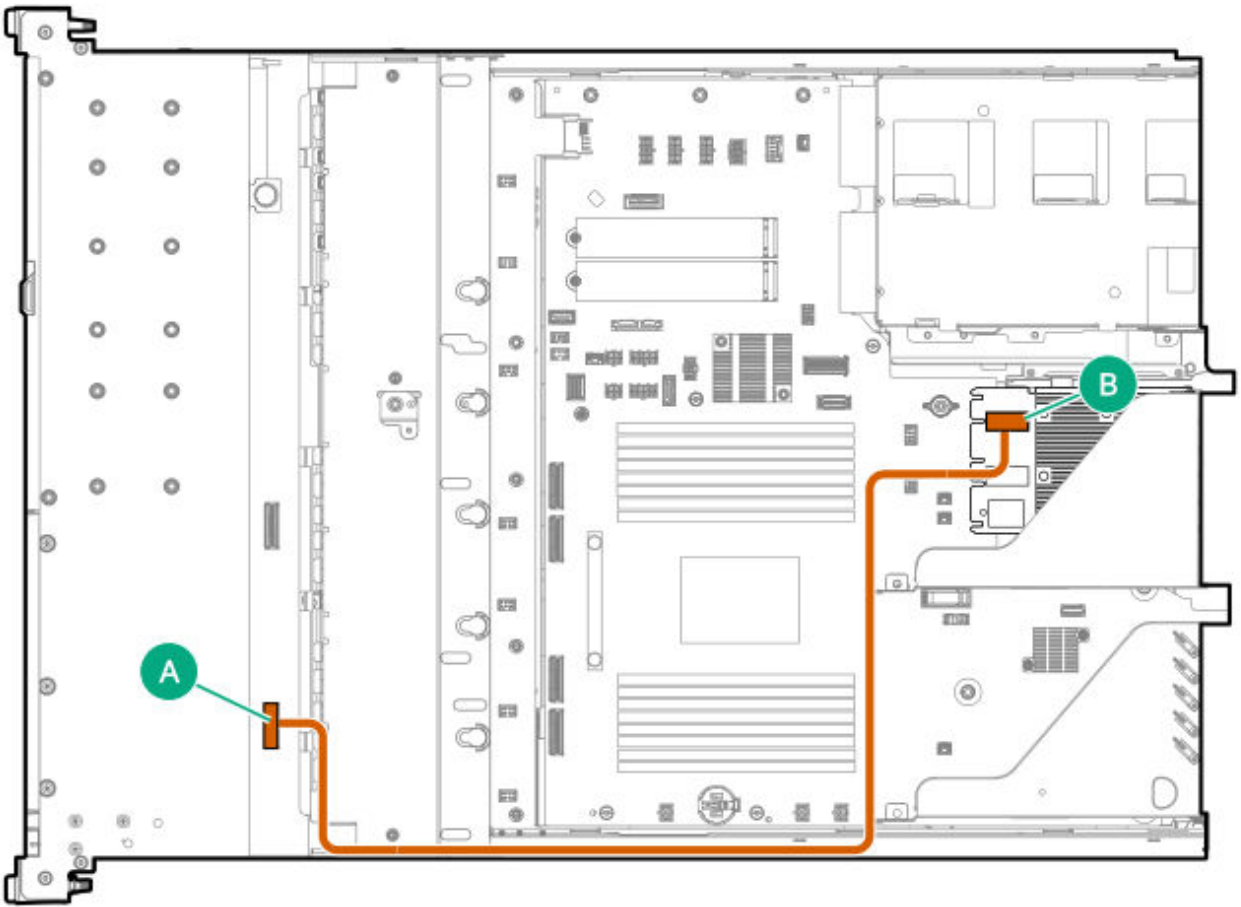

Cable part number	Color	From	To
P48960-001	Orange	2 SFF drive backplane	Type-o controller port 1

4 LFF drive controller cabling

4 LFF drive: Onboard SATA cabling

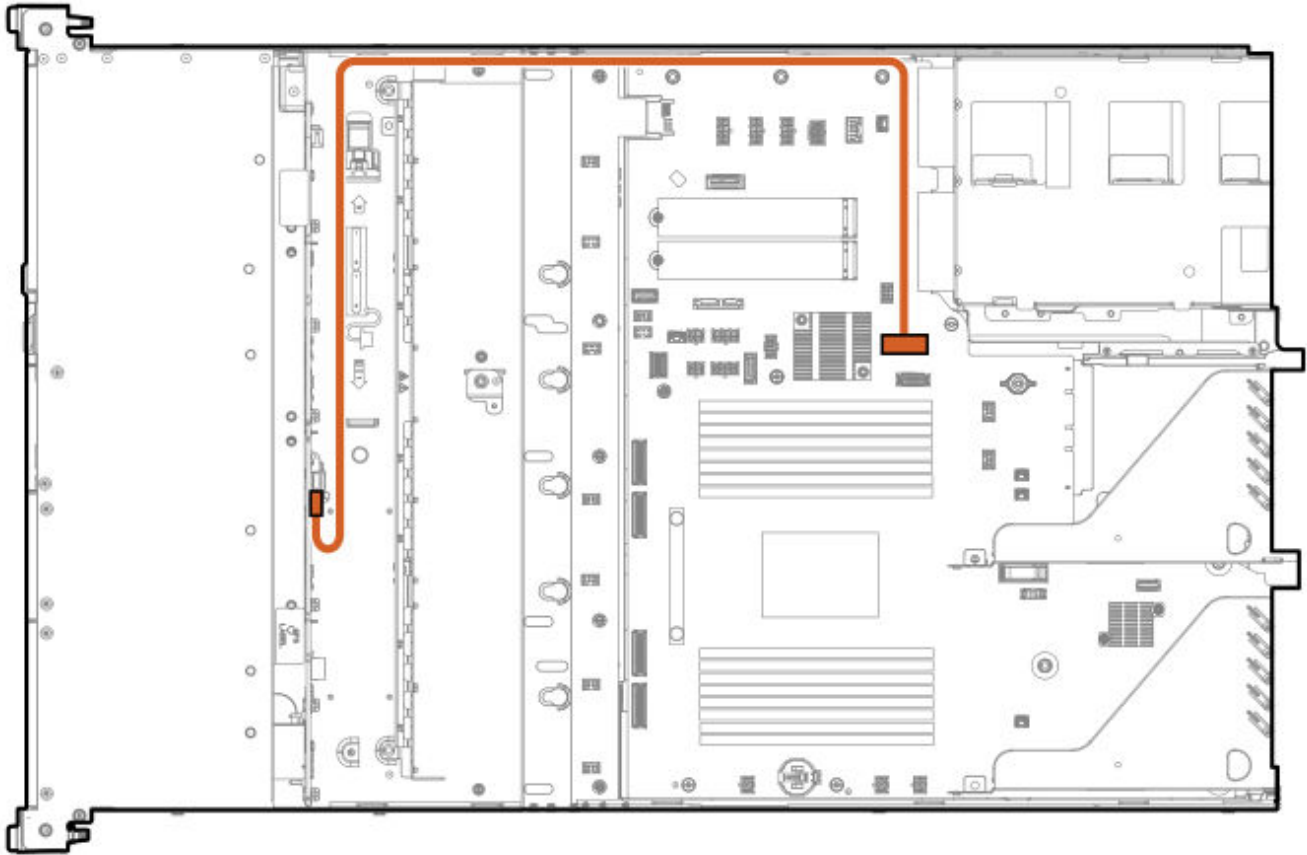

Cable part number	Color	From	To
P53989-001	Orange	4 LFF drive backplane	x8 slimSAS port 1

4 LFF drive: Type-o controller cabling

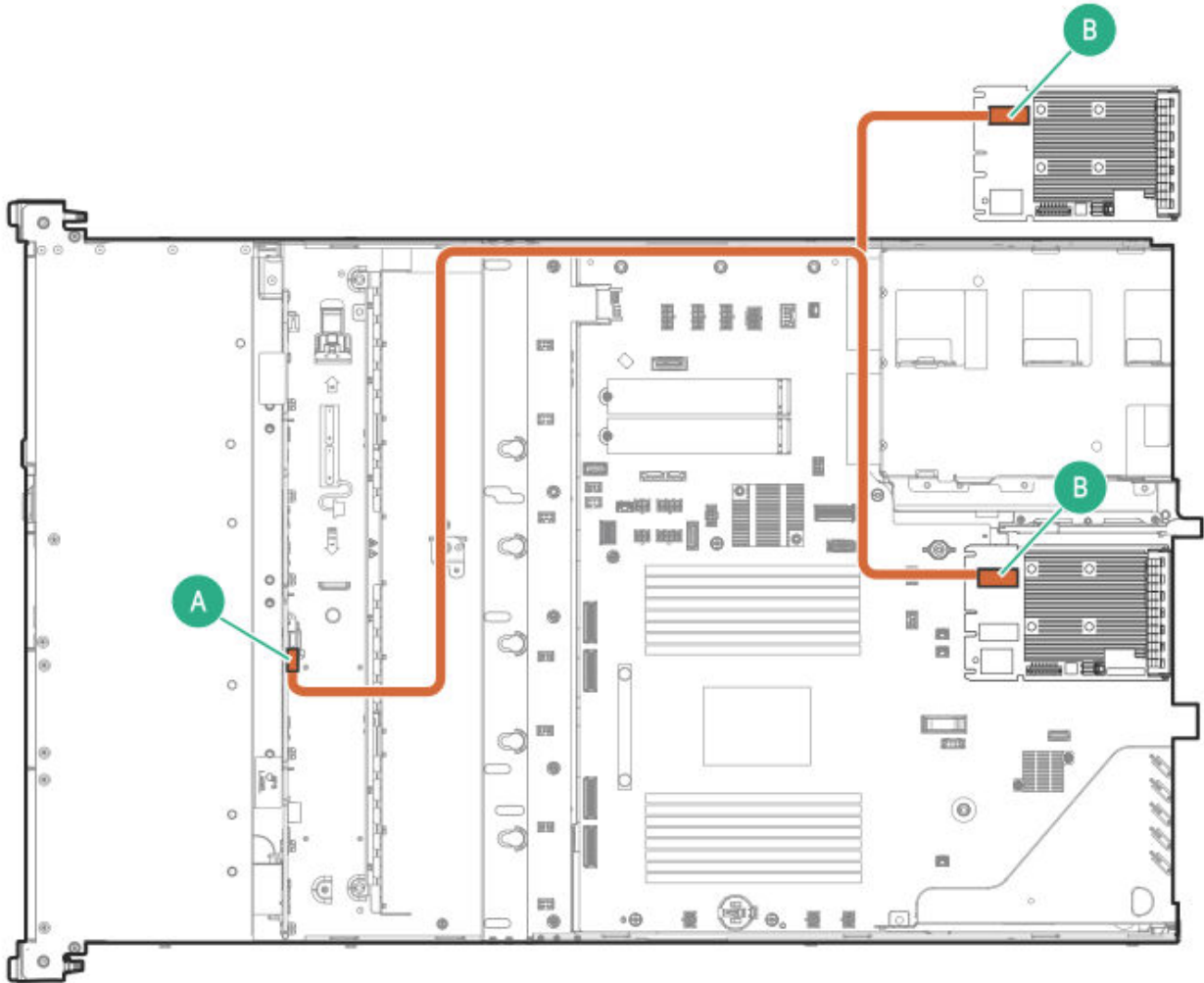

Cable part number	Color	From	To
P53989-001	Orange	4 LFF drive backplane	Port 1 or port 2 ¹

¹ The cable connects to port 1 on a controller with one port and port 1 or port 2 on a controller with two ports.

10 LFF drive controller cabling

10 LFF drive: Onboard SAS/SATA cabling

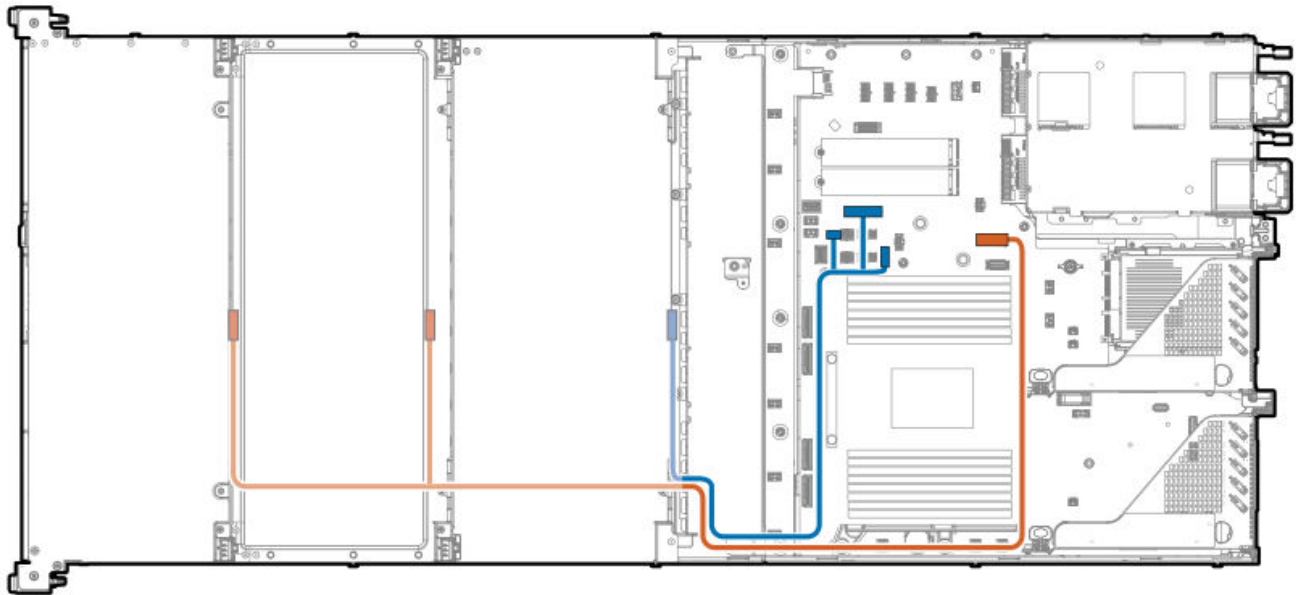

Cable part number	Color	From	To
P54928-001 ¹ / _—	Orange	4 LFF drive backplane box 1 and box 3	x8 slimSAS port 1
P54929-001 ¹ / _—	Blue	4 LFF drive backplane box 5	SATA sideband connector and Optical drive power connector and SATA 6 G b/s port

¹/_— Option kit: P59459-B21

12 LFF drive controller cabling

12 LFF drive: Secondary type-p controller cabling

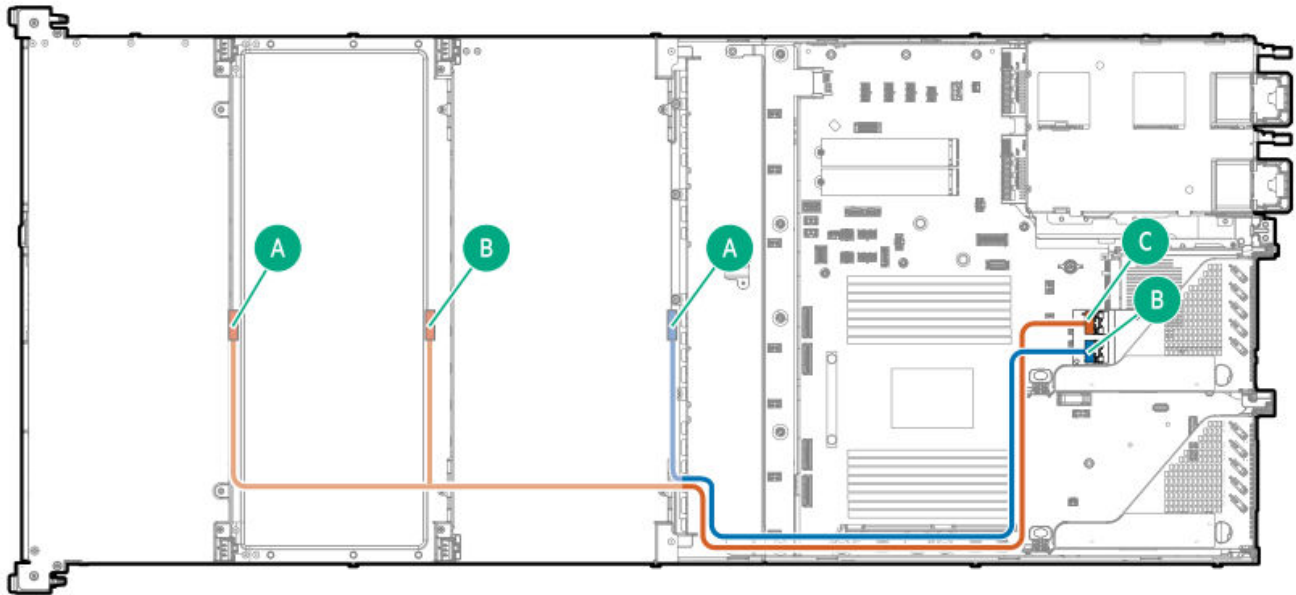

Cable part number	Color	From	To
P54930-001 ¹ / _—	Orange	4 LFF drive backplane box 1 and box 3	Port 1
P54931-001 ¹ / _—	Blue	4 LFF drive backplane box 5	Port 2

¹/_— Option kit: P60892-B21

Energy pack cabling

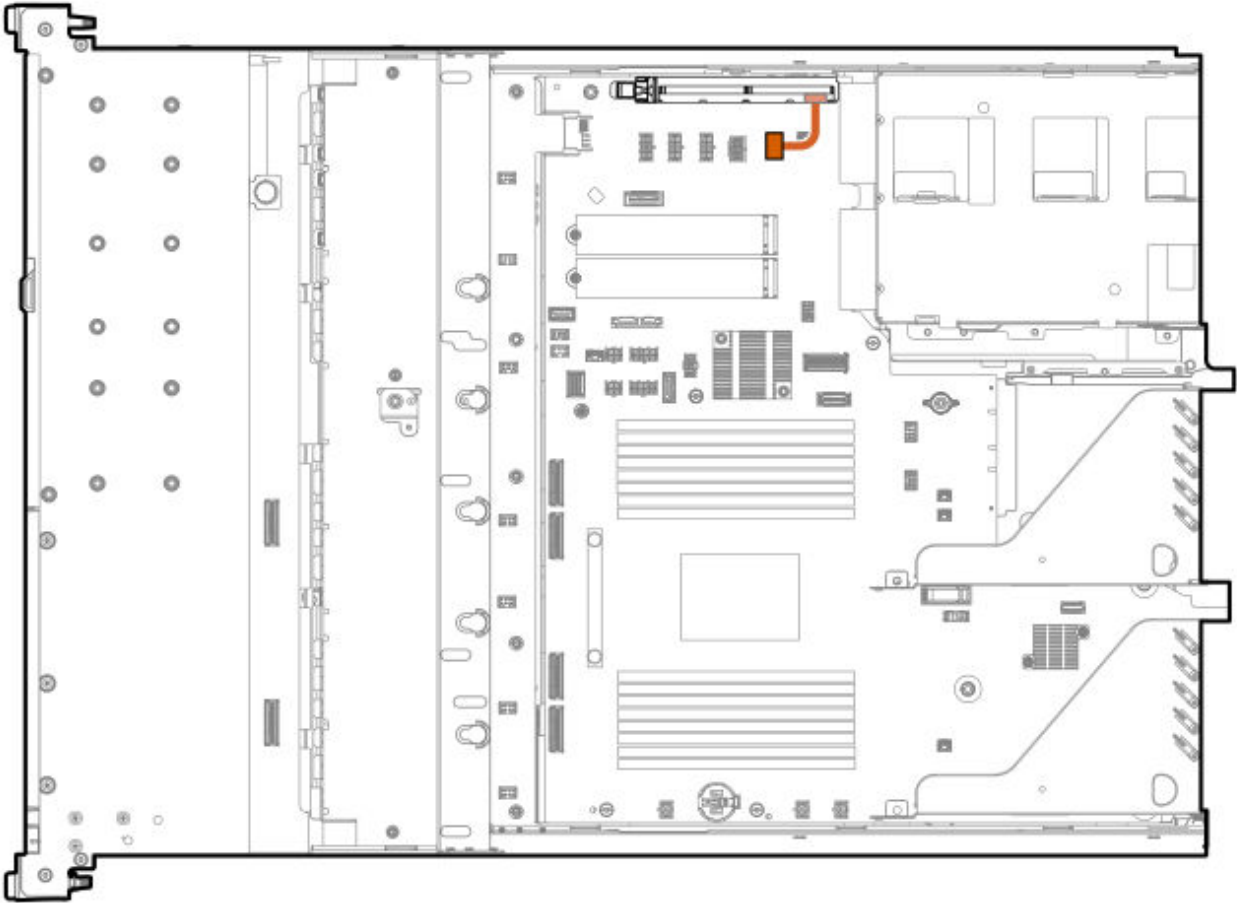

Cable part number	Color	From	To
P01366-B21	Orange	Energy pack connector	Energy pack

Storage controller backup cabling

The exact route of the storage controller backup power cabling will depend on:

- The riser slot where the controller is installed
- The location of the storage controller backup power connector on the controller

Use the following diagrams for reference only.

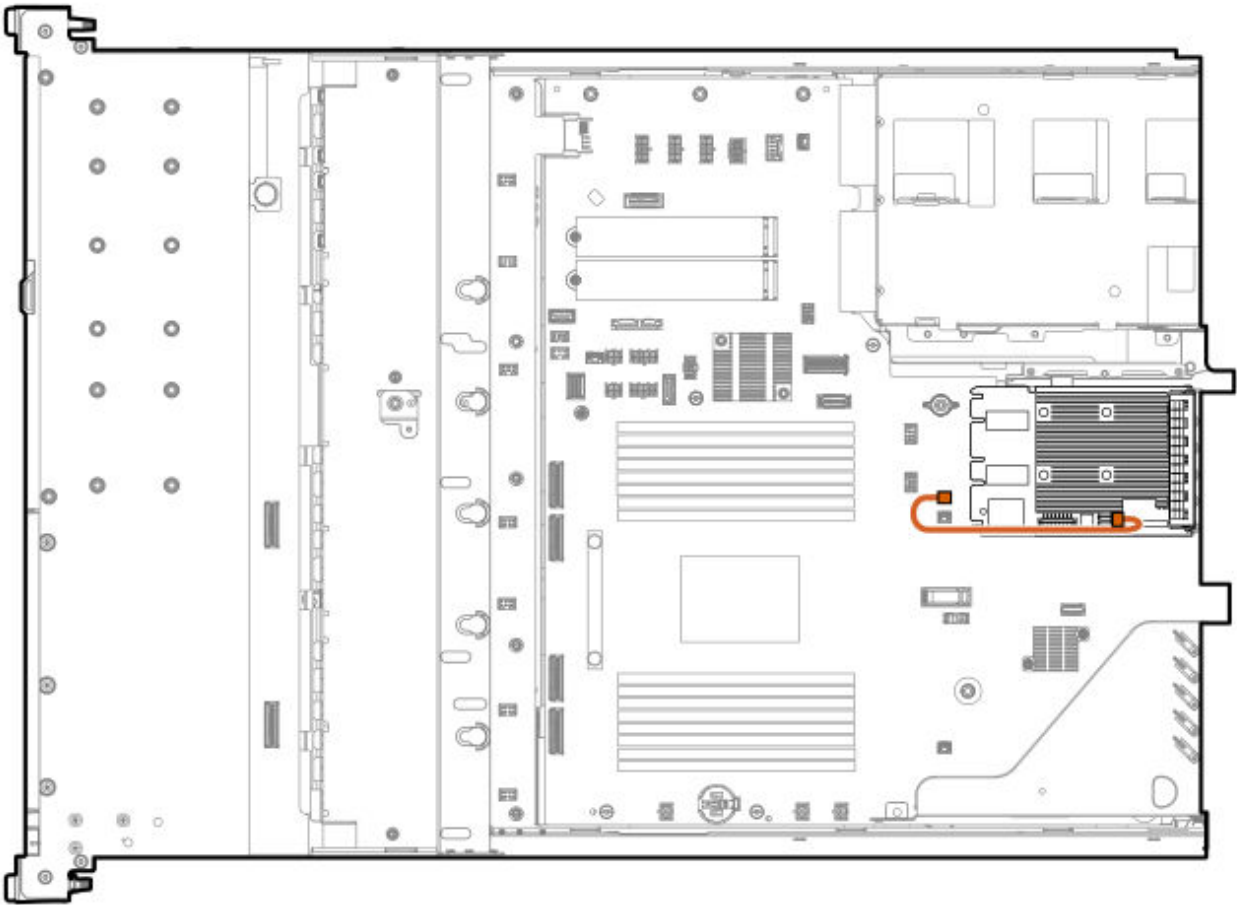

Cable part number	From	To
877849-001	OCP port	Storage controller backup power connector

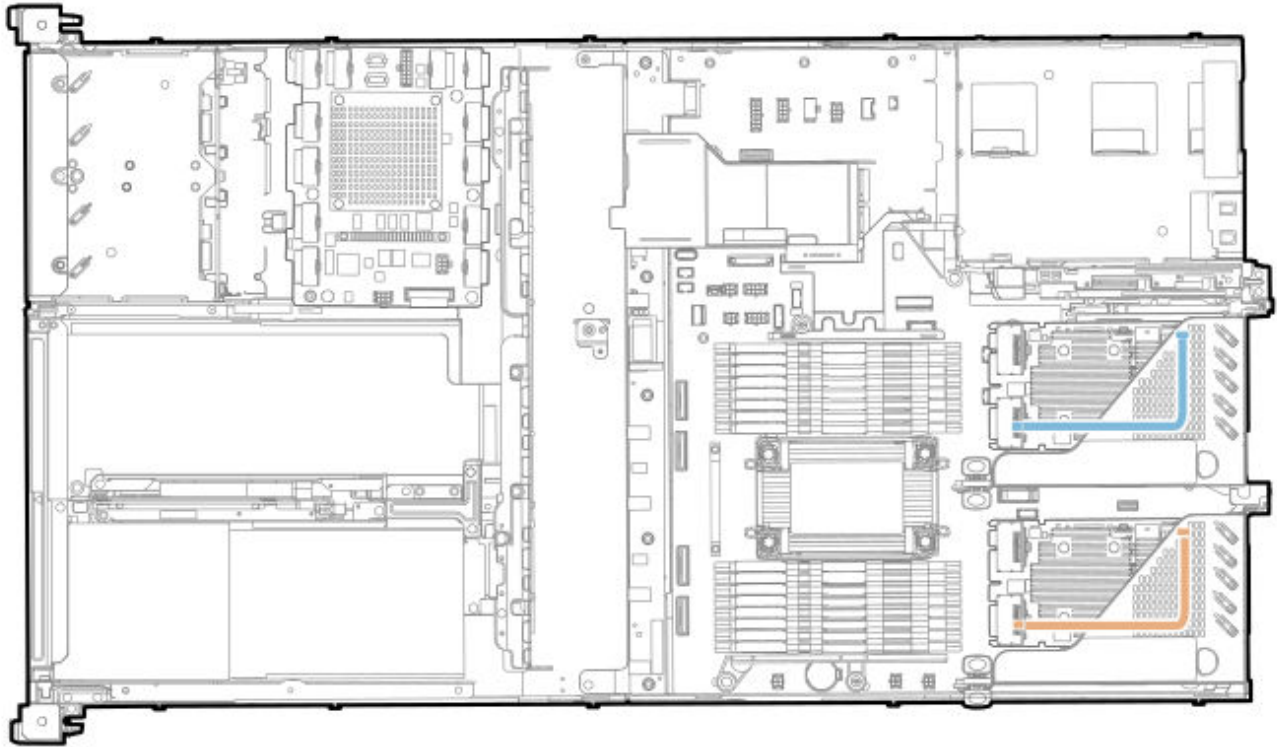

Color	From	To
Orange	Primary type-p controller	Storage controller backup power connector for slot 1
Blue	Secondary type-p controller	Storage controller backup power connector for slot 2

Accelerator cabling

Subtopics

[GPU auxiliary power cabling](#)

[GPU riser cabling](#)

GPU auxiliary power cabling

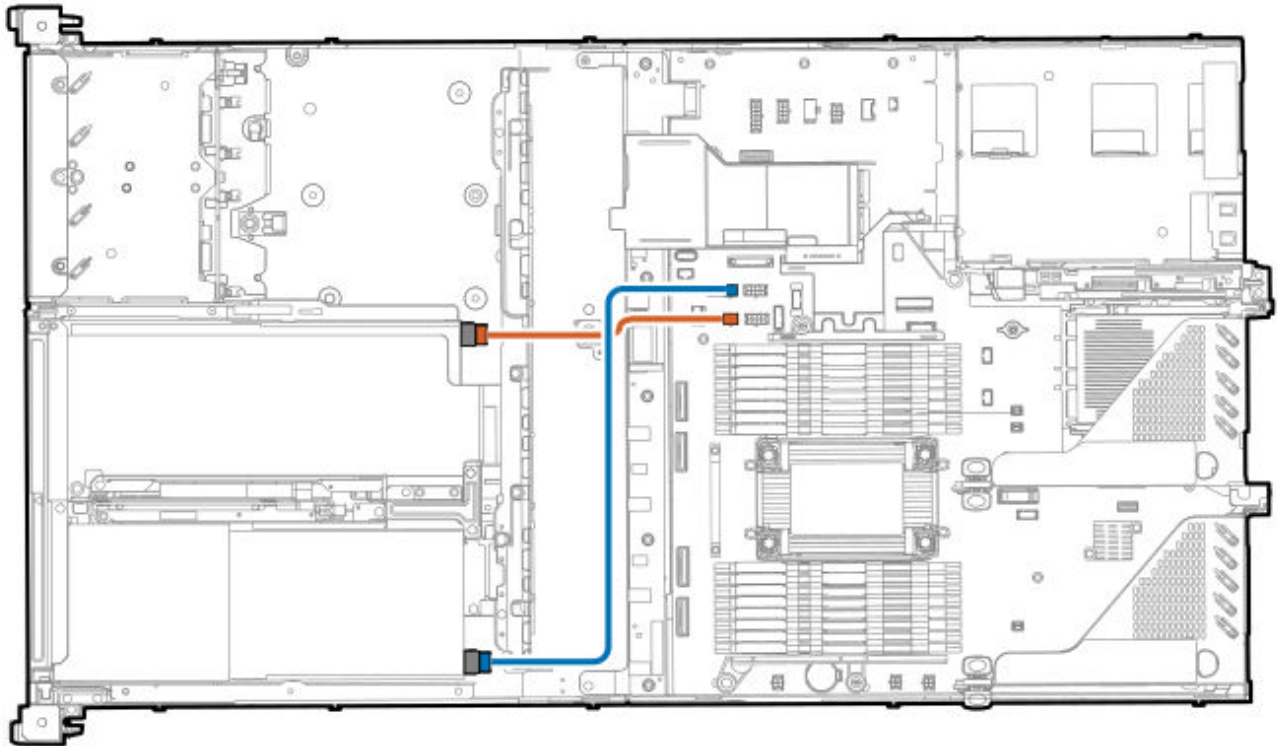

Cable part number	Color	From	To
P60495-001 ¹ / _—	Orange	GPU power port on the primary GPU riser cage	GPU auxiliary power connector
P61488-001 ² / _—			
P68828-001 ³ / _—			
P61487-001 ⁴ / _—	Blue	GPU power port on the secondary GPU riser cage	GPU auxiliary power connector
P61489-001 ⁵ / _—			
P68829-001 ⁶ / _—			

- ¹/_— Option kit: P62201-B21
- ²/_— Option kit: P62205-B21
- ³/_— Option kit: P69104-B21
- ⁴/_— Option kit: P62203-B21
- ⁵/_— Option kit: P62207-B21
- ⁶/_— Option kit: P69106-B21

GPU riser cabling

GPU riser power cabling

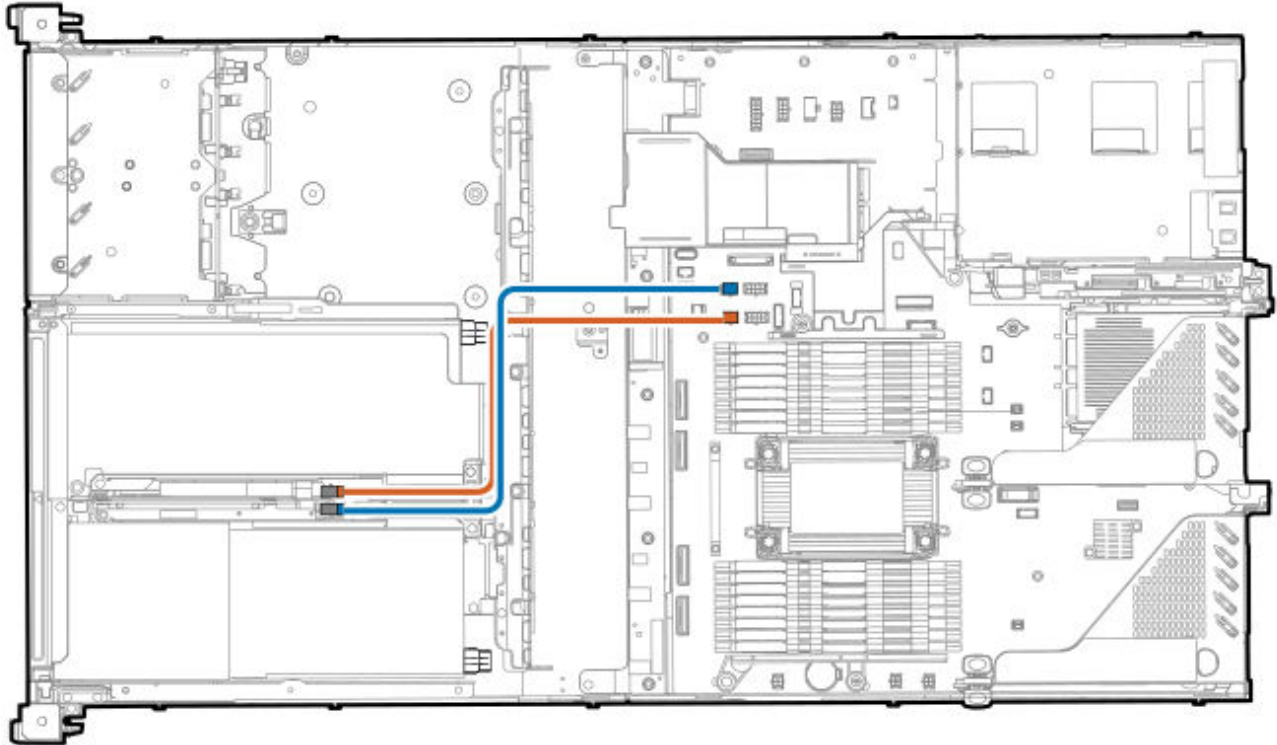

Cable part number	Color	From	To
P60489-001 ¹ / _—	Orange	GPU primary riser	GPU riser power connector
P60490-001 ¹ / _—	Blue	GPU secondary riser	

¹/_— Option kit: P62197-B21

GPU riser signal cabling

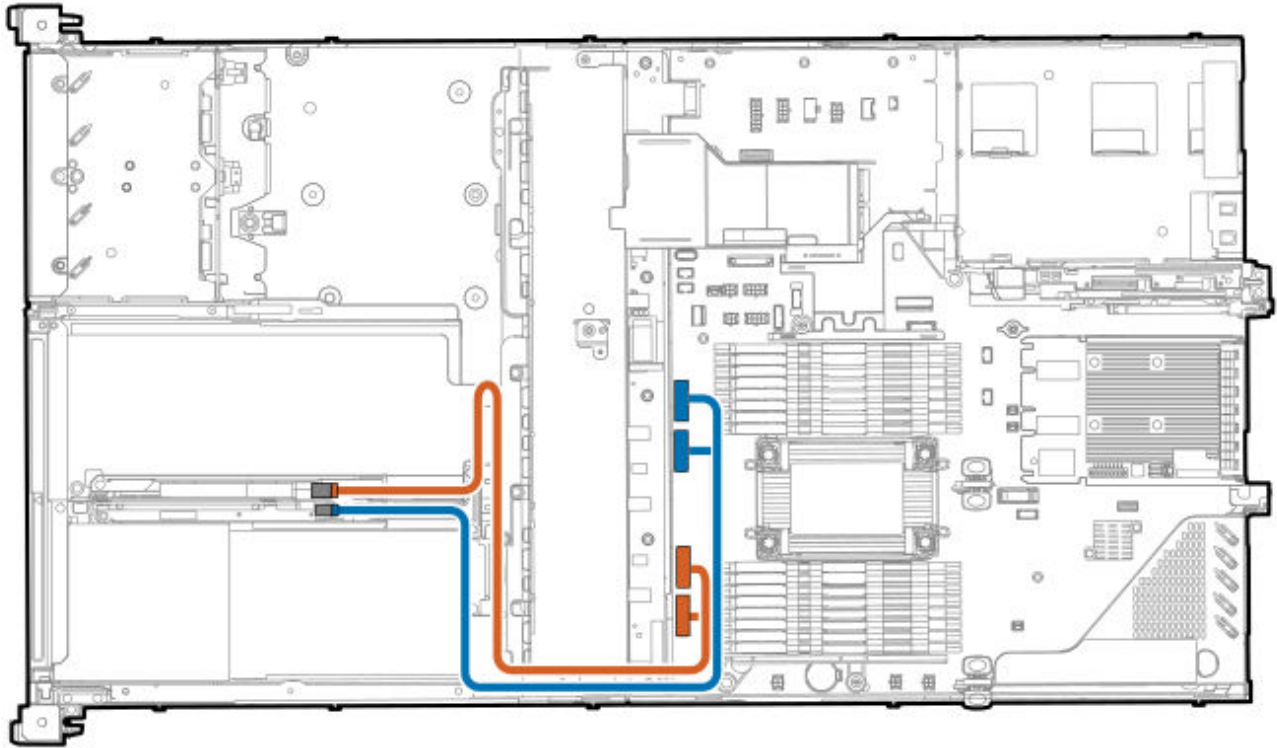

Cable part number	Color	From	To
P51471-001 ¹ _—	Orange	GPU primary riser	MCI O port 1 and MCI O port 2
	Blue	GPU secondary riser	MCI O port 3 and MCI O port 4

¹ _— Option kit: P62197-B21

GPU riser power cabling to the switch board

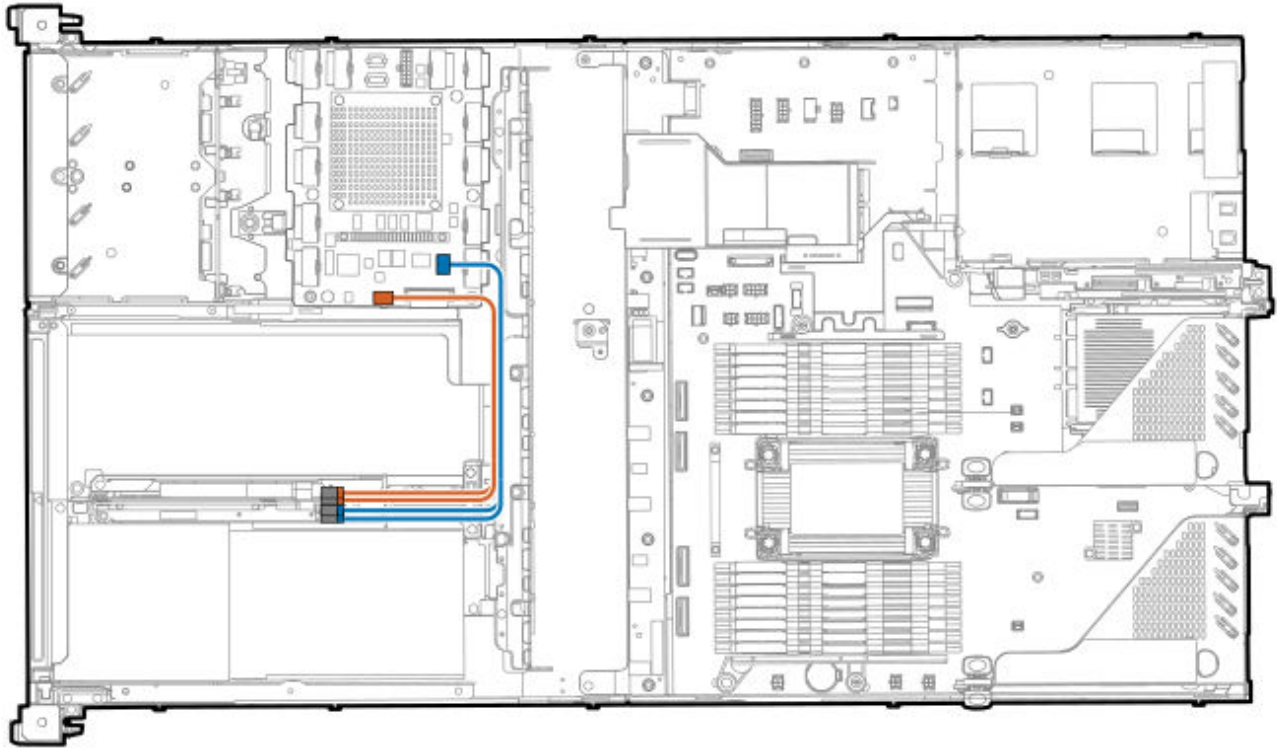

Cable part number	Color	From	To
P60494-001	Orange	GPU riser in slot 5 and 6	GPU riser slot 5 and 6 power connector
P60493-001	Blue	GPU riser in slot 3 and 4	GPU riser slot 3 and 4 power connector

GPU riser signal cabling to the switch board

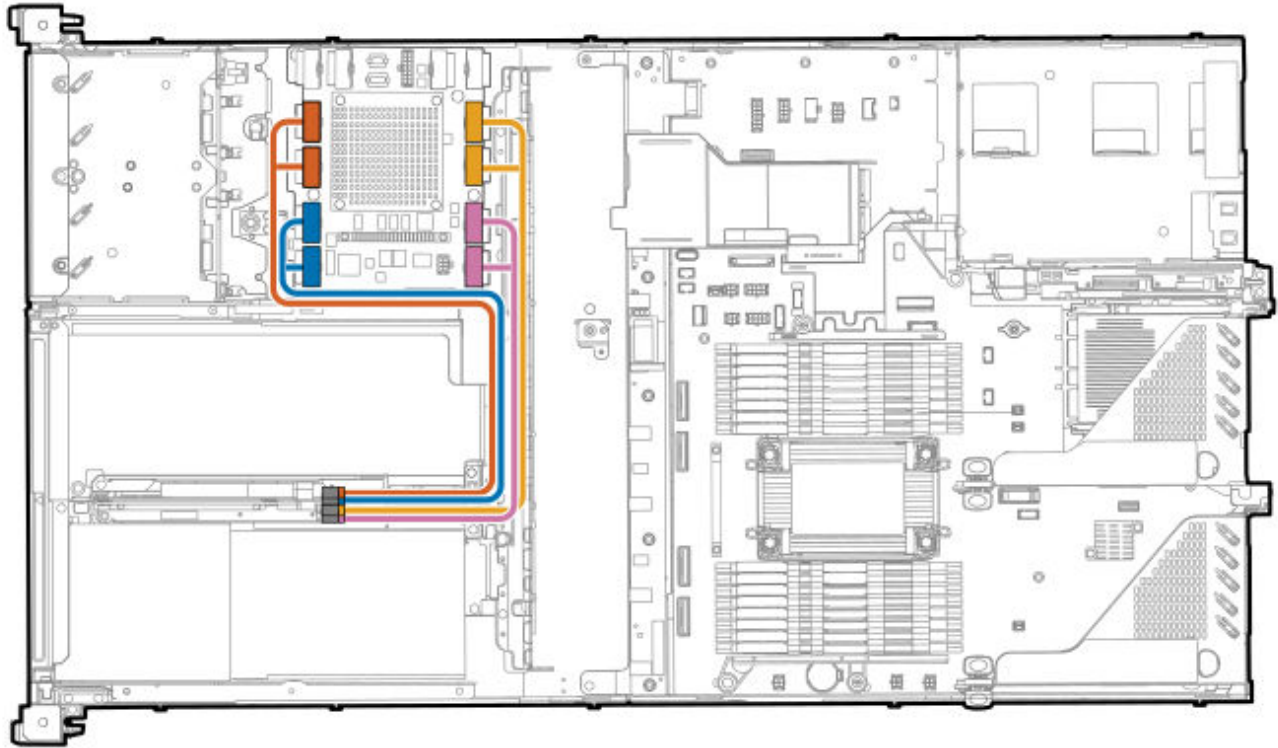

Cable part number	Color	From	To
P44002-001	Orange	P2 GPU riser slot 3 MCIO connector (PRIM)	GPU riser slot 3 connector (SEC)
		P3 GPU riser slot 3 MCIO connector (SEC)	
	Blue	P2 GPU riser slot 4 MCIO connector (PRIM)	GPU riser slot 4 connector (SEC)
		P3 GPU riser slot 4 MCIO connector (SEC)	
P55910-001	Yellow	P2 GPU riser slot 5 MCIO connector (PRIM)	GPU riser slot 5 connector (SEC)
		P3 GPU riser slot 5 MCIO connector (SEC)	
	Pink	P2 GPU riser slot 6 MCIO connector (PRIM)	GPU riser slot 6 connector (SEC)

Cable part number	Color	From	To
		P3 GPU riser slot 6 MCIO connector (SEC)	

HPE NS204i Boot Device cabling

HPE NS204i Boot Device cabling: Option 1

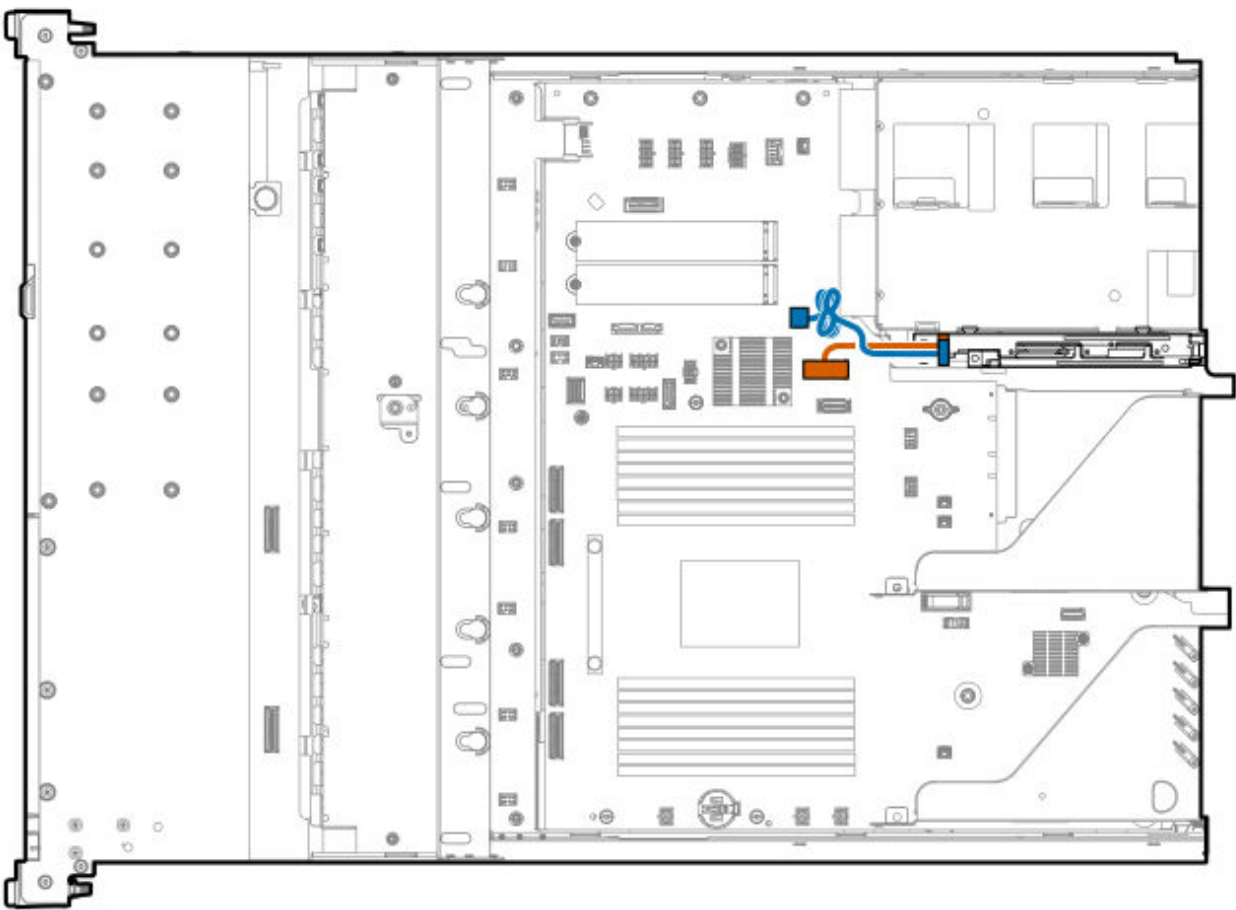

Cable part number	Color	From	To
P54087-001 <u>1</u>	Orange	Boot device carrier	x8 slimSAS port 1

Cable part number	Color	From	To
P54088-001 ¹ _—	Blue	Boot device carrier	M.2 boot device power connector

¹_— Option kit: P52786-B21

HPE NS204i Boot Device cabling: Option 2

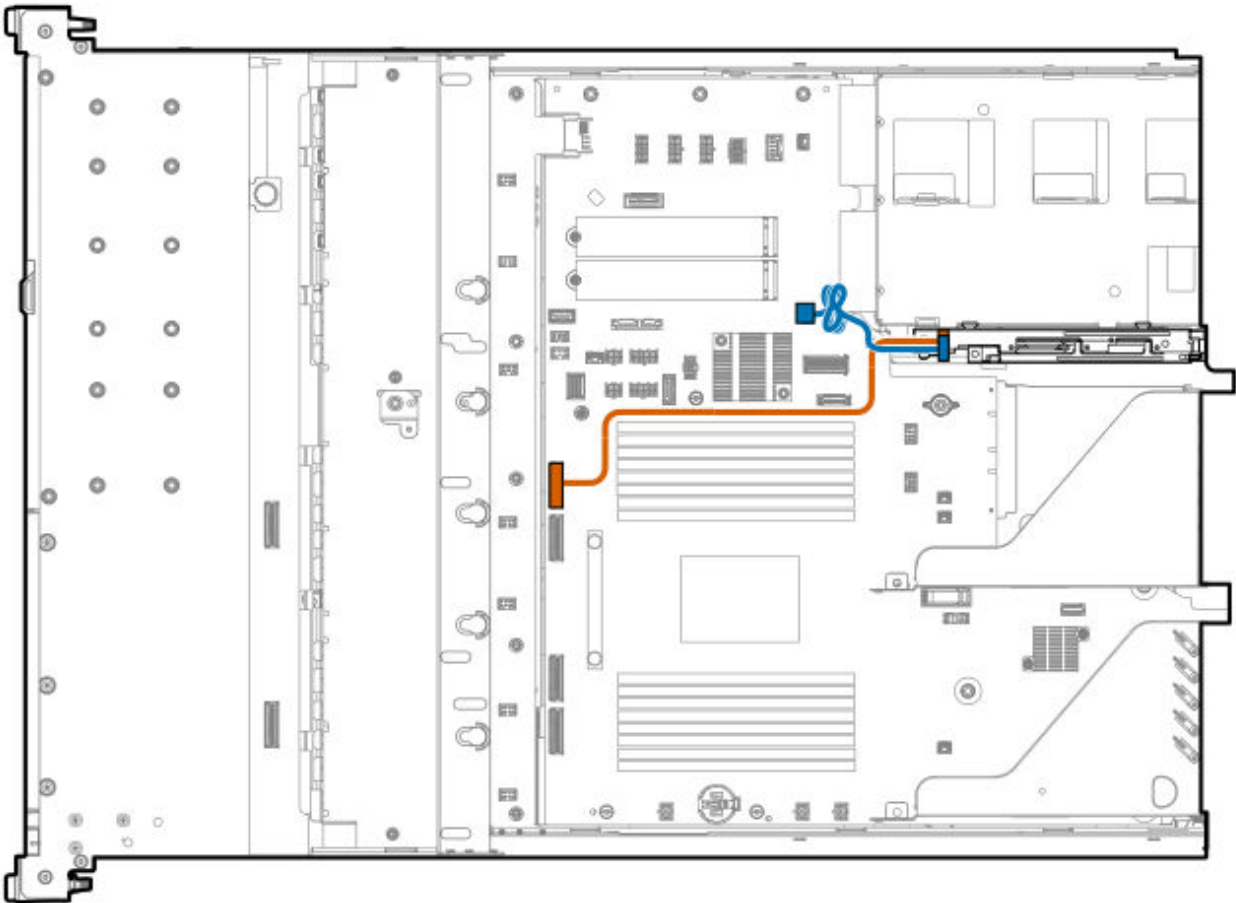

Cable part number	Color	From	To
P56364-001 ¹ _—	Orange	Boot device carrier	MCI0 port 4
P54088-001 ¹ _—	Blue	Boot device carrier	M.2 boot device power connector

¹_— Option kit: P52786-B21

Switch board cabling

Power cabling

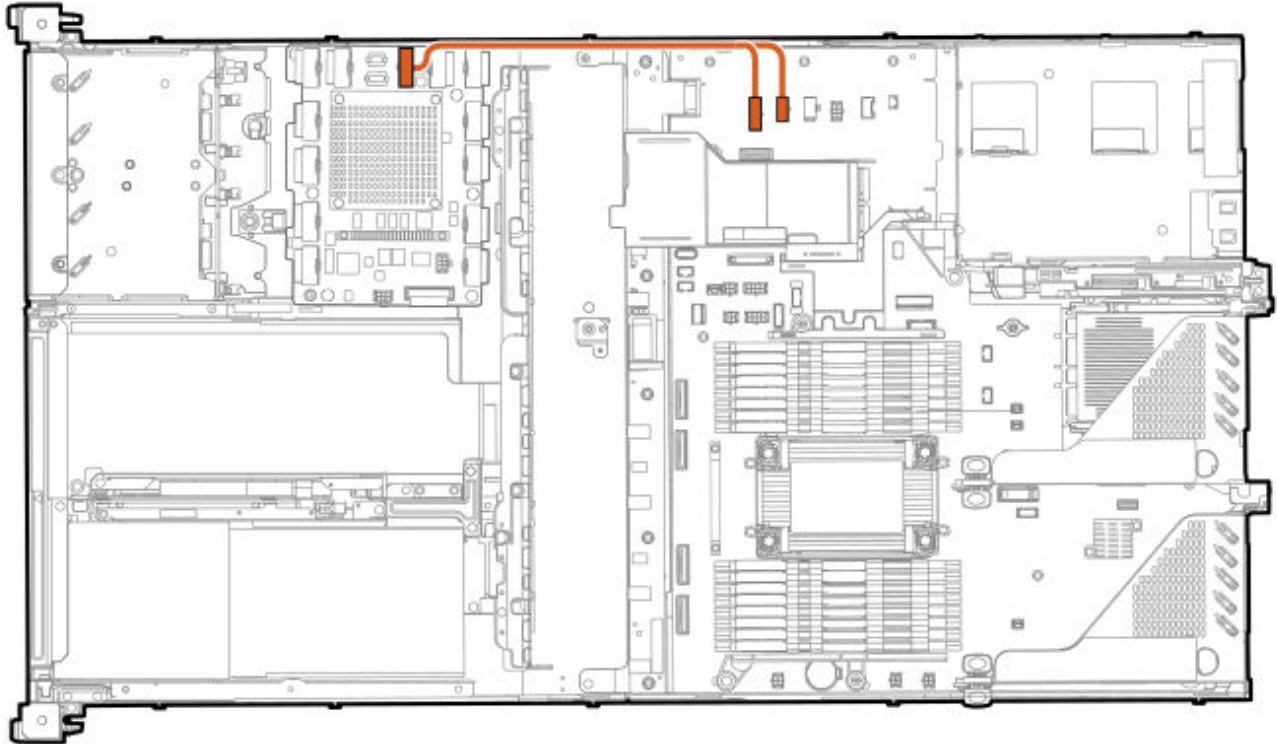

Cable part number	Color	From	To
P60491-001	Orange	Switch board power connector	Drive box 5 power connector and Drive box 3 power connector

Signal cabling

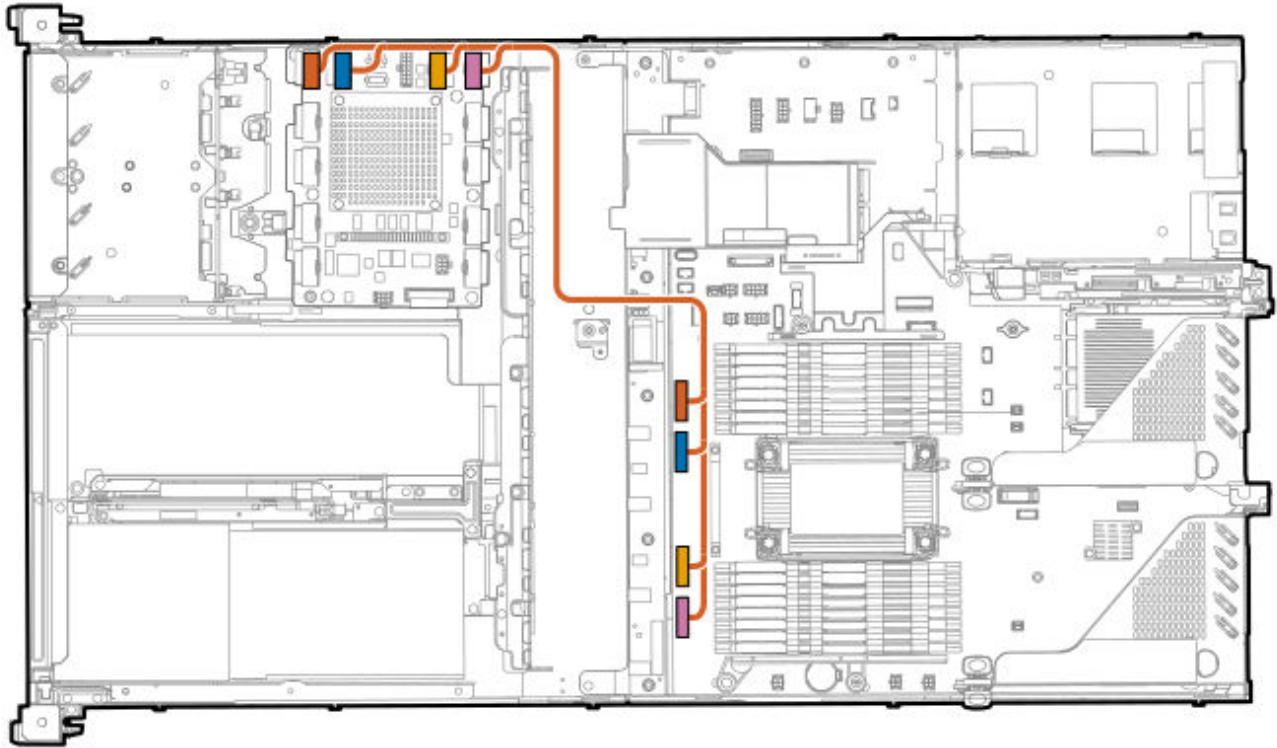

Cable part number	Color	From	To
P60492-001	Orange	Switch board downstream port 1	MCI/O port 4
	Blue	Switch board downstream port 2	MCI/O port 3
	Yellow	Switch board downstream port 3	MCI/O port 2
	Pink	Switch board downstream port 4	MCI/O port 1

Sideband cabling

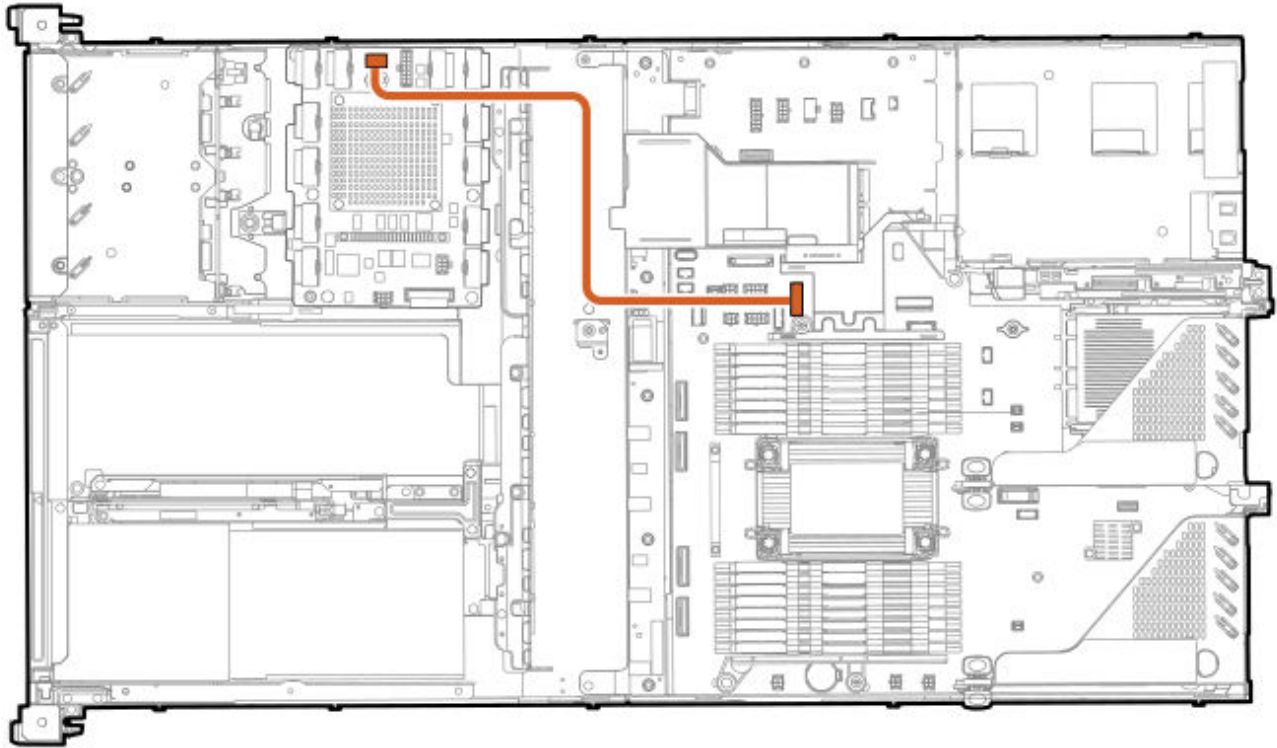

Cable part number	Color	From	To
P54897-001	Orange	Switch board signal extension connector	Switch board sideband connector

Optical drive cabling

8 SFF drive: Optical drive cabling

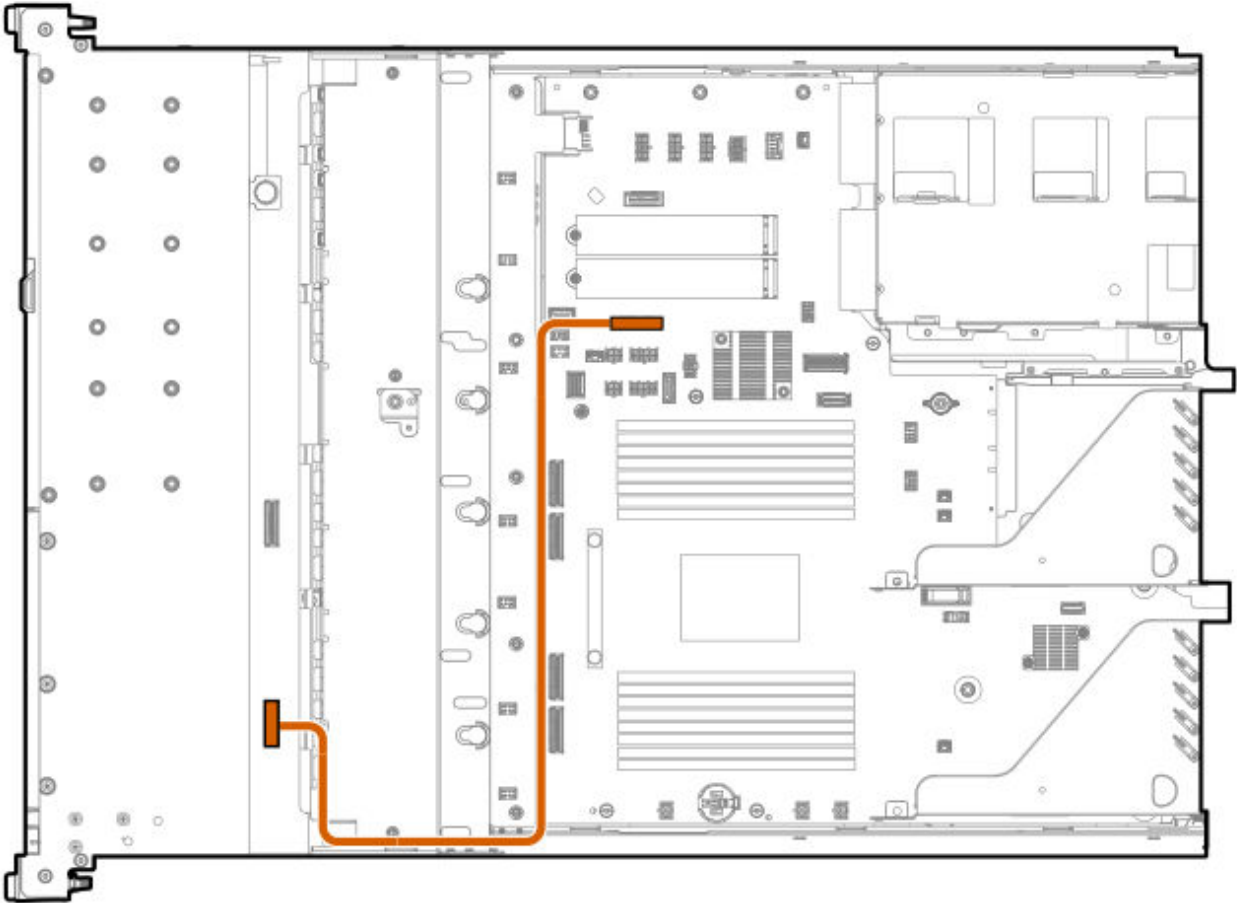

Cable part number	Color	From	To
P45622-001 ¹ / _—	Orange	Optical drive	Optical drive connector

¹/_— Option kit: P54641-B21

4 LFF drive: Optical drive cabling

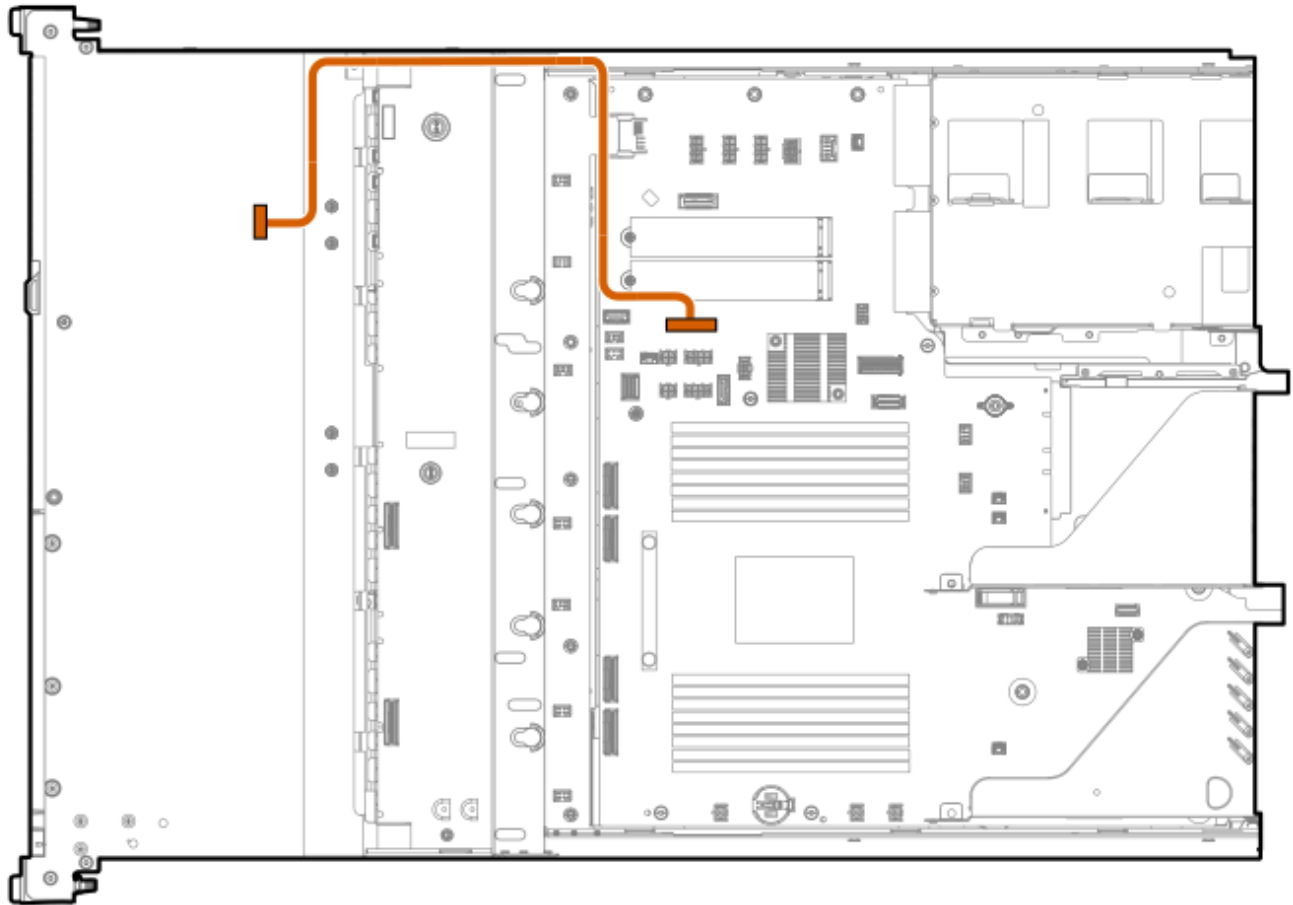

Cable part number	From	To
P45622-001 ¹ / _—	Optical drive	Optical drive connector

¹/_— Option kit: P54641-B21

Display port cabling

8 SFF drive: Display port cabling

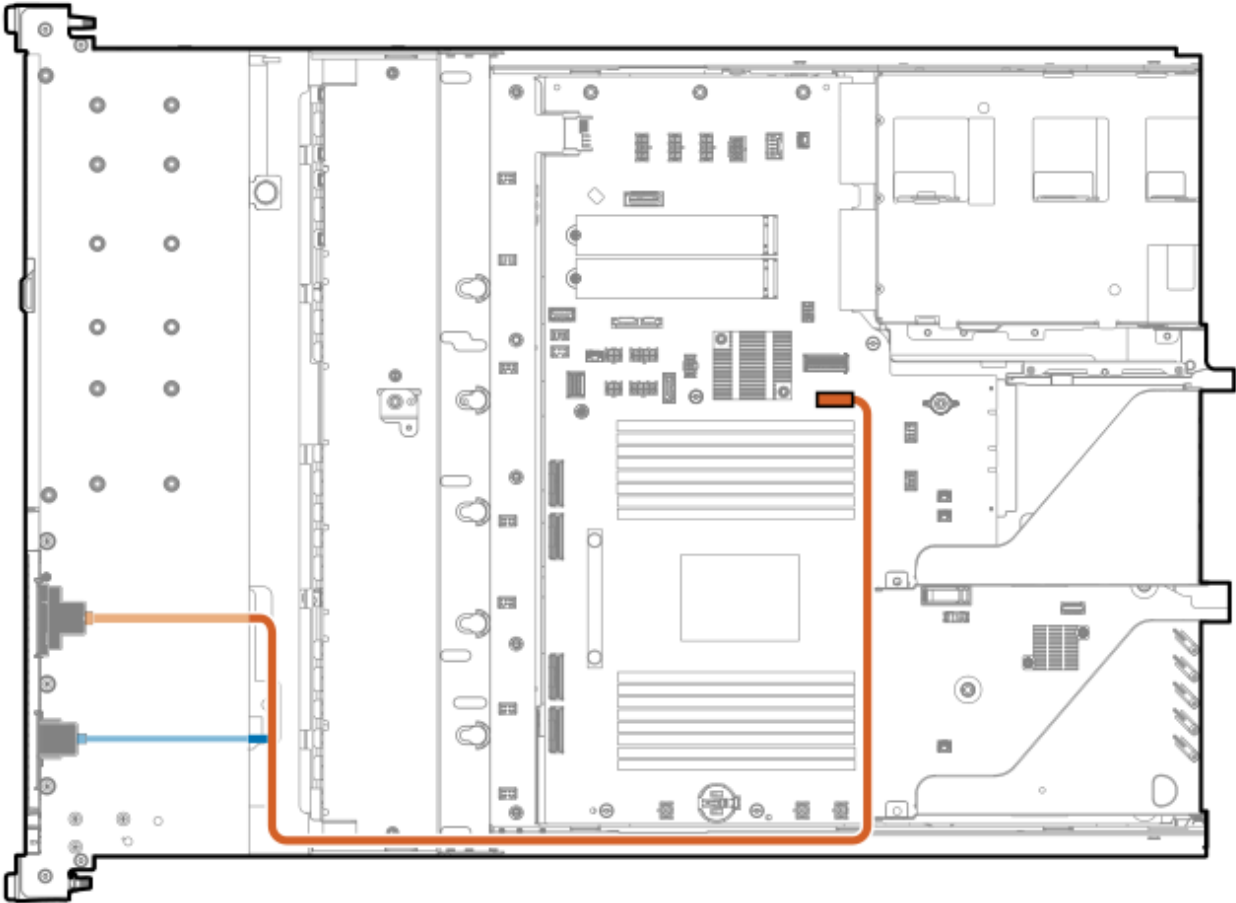

Cable part number	Color	From	To
P45620-001 ¹ / _—	Orange	Display port	Display port cable connector
	Blue	USB 2.0 port	

¹/_— Option kit: P48926-B21

4 LFF drive: Display port cabling

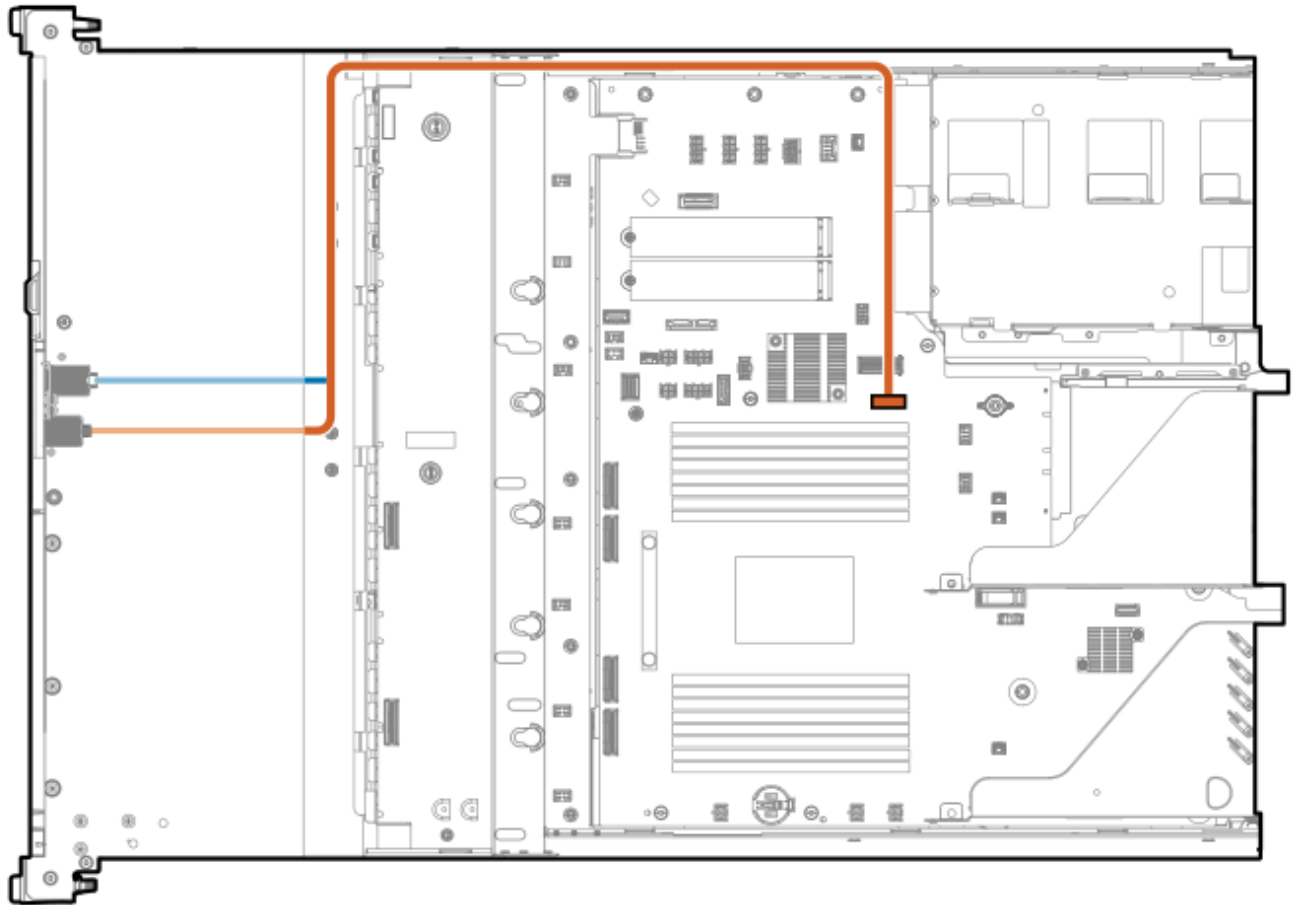

Cable part number	Color	From	To
P45619-001 ¹ / _—	Orange	Display port	Display port cable connector
	Blue	USB 2.0 port	

¹/_— Option kit: P48928-B21

Serial port cabling

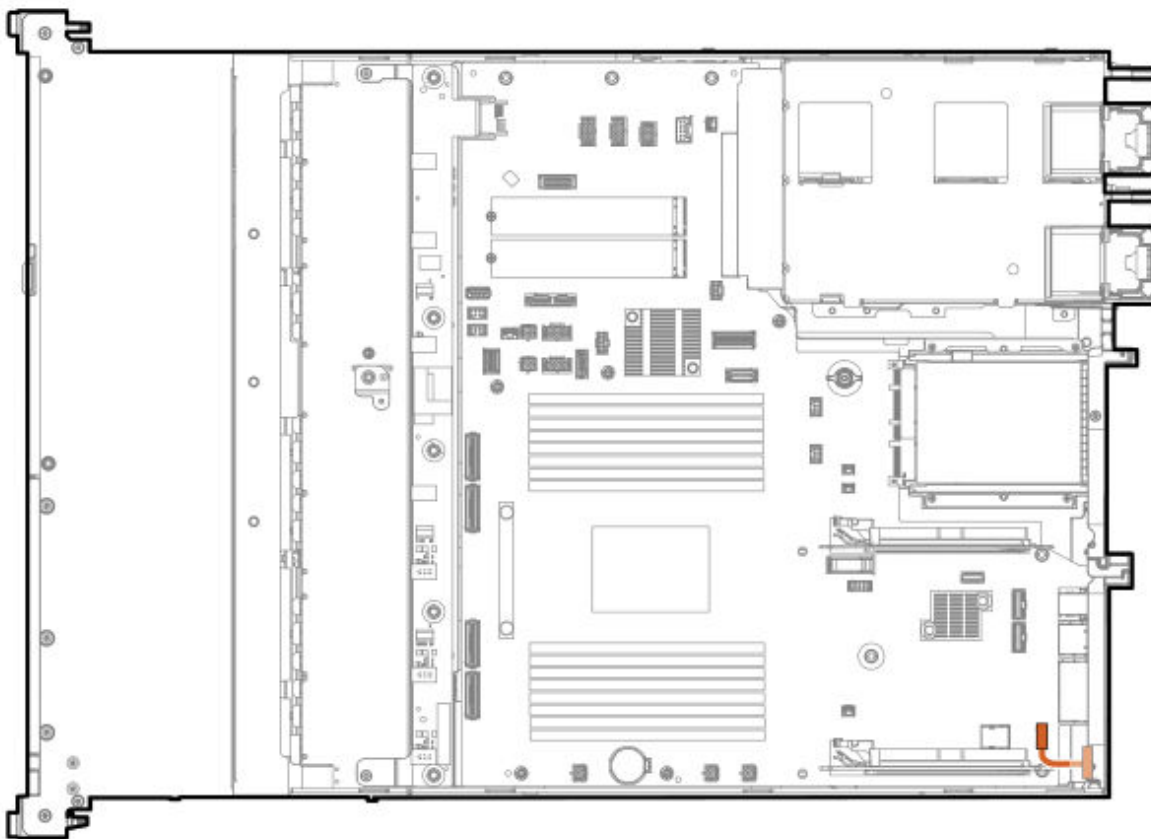

Cable part number	Color	From	To
P47752-001 ¹ / _—	Orange	Serial port	Serial port connector

¹/_— Option kit: P58829-B21

Front I/O cabling

8 SFF drive and 4 LFF drive: Front I/O cabling

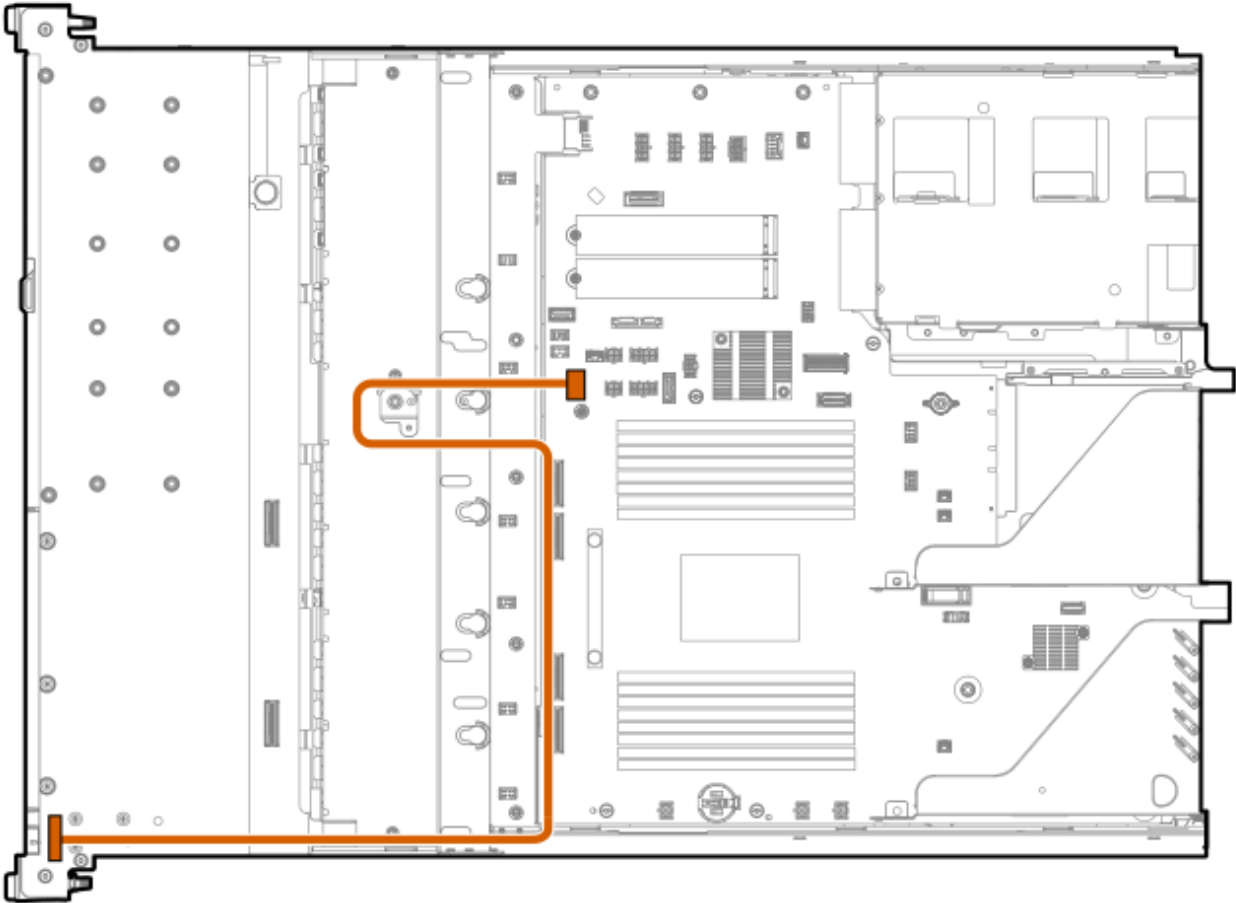

Cable part number	Color	From	To
P43727-001	Orange	Front I/O	Front I/O connector

10/12 LFF drive: Front I/O cabling

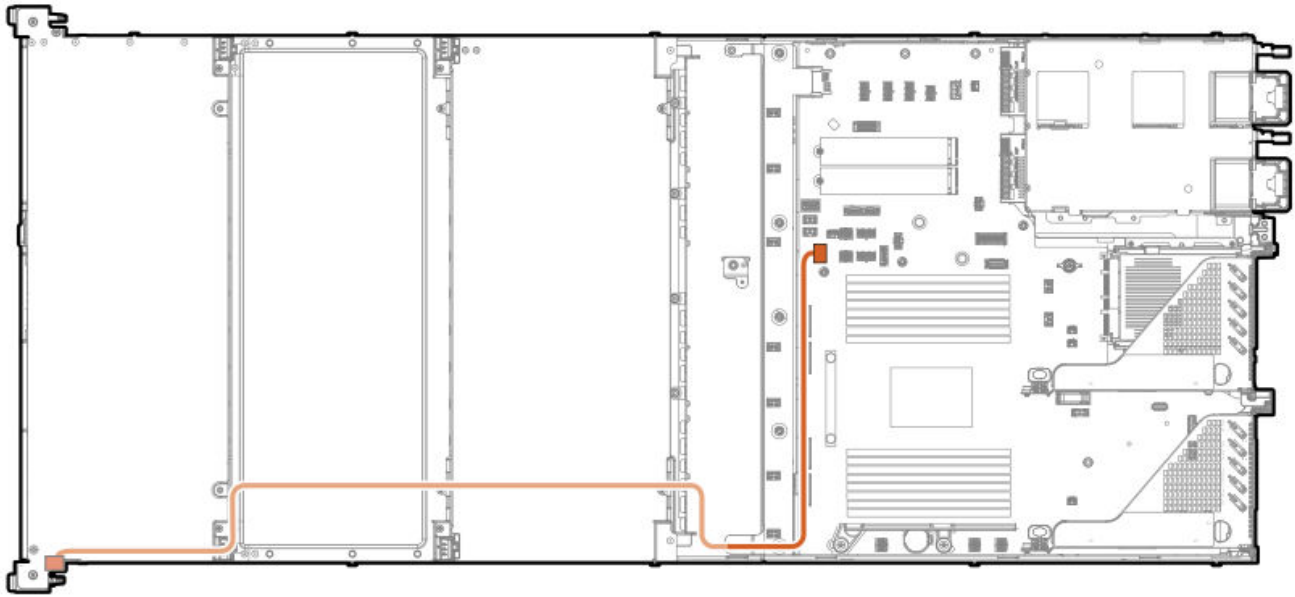

Cable part number	Color	From	To
P54923-001	Orange	Front I/O	Front I/O connector

GPU dense: Front I/O cabling

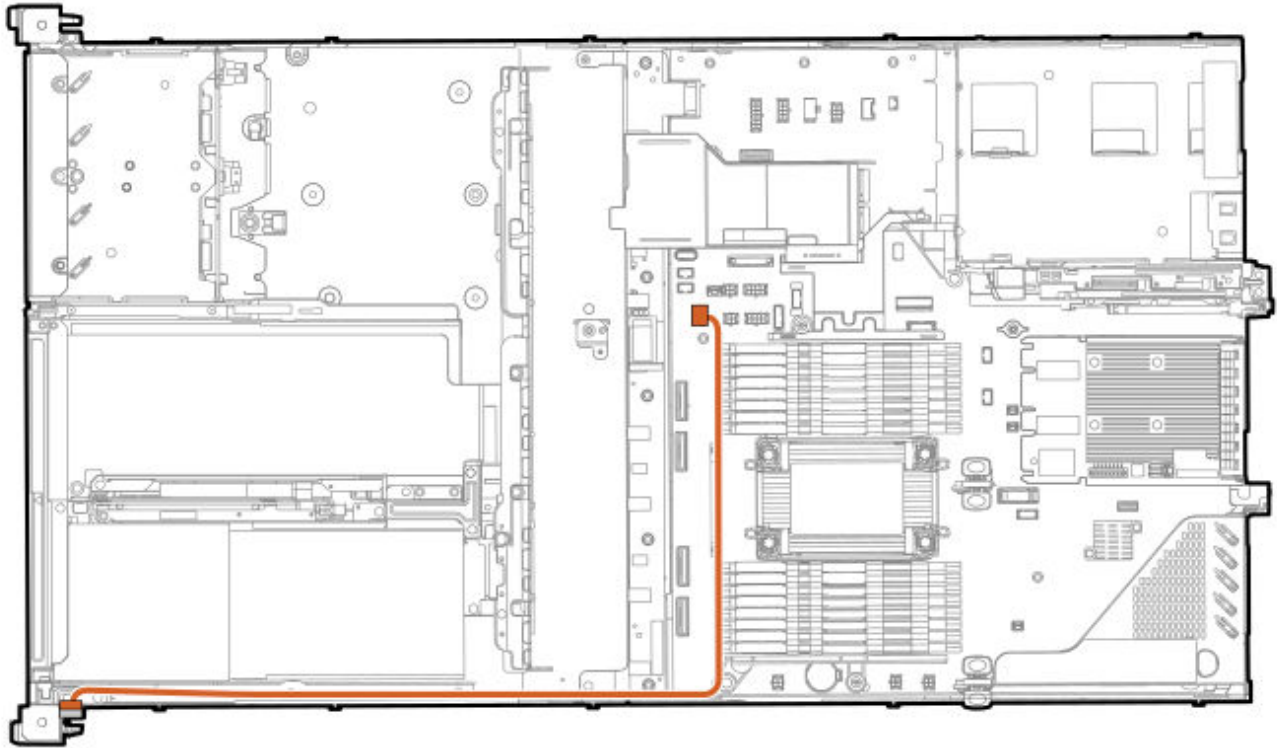

Cable part number	Color	From	To
P47750-001	Orange	Front I/O	Front I/O connector

VGA cabling

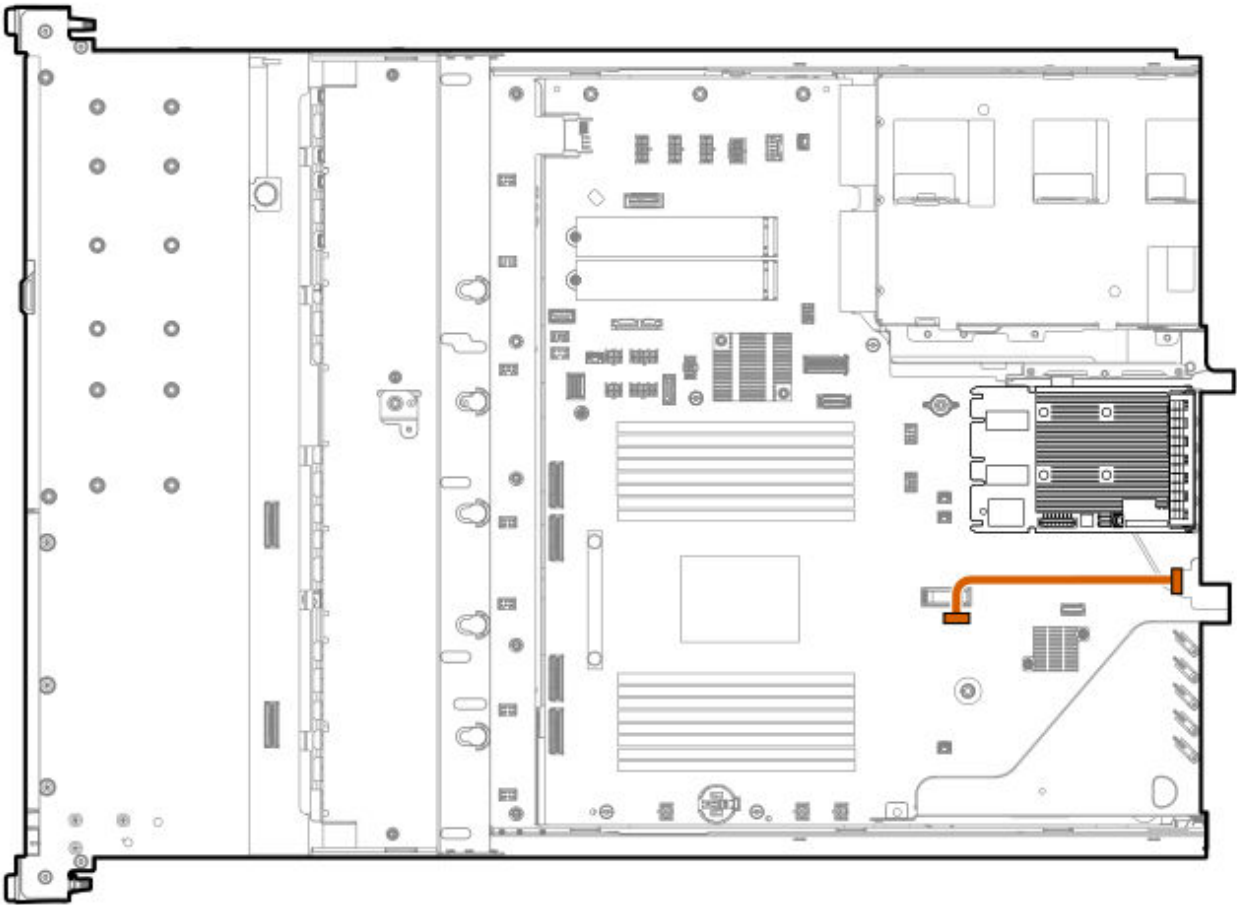

Cable part number	Color	From	To
P53987-001	Orange	VGA cable	Video (VGA) connector

Chassis intrusion detection switch cabling

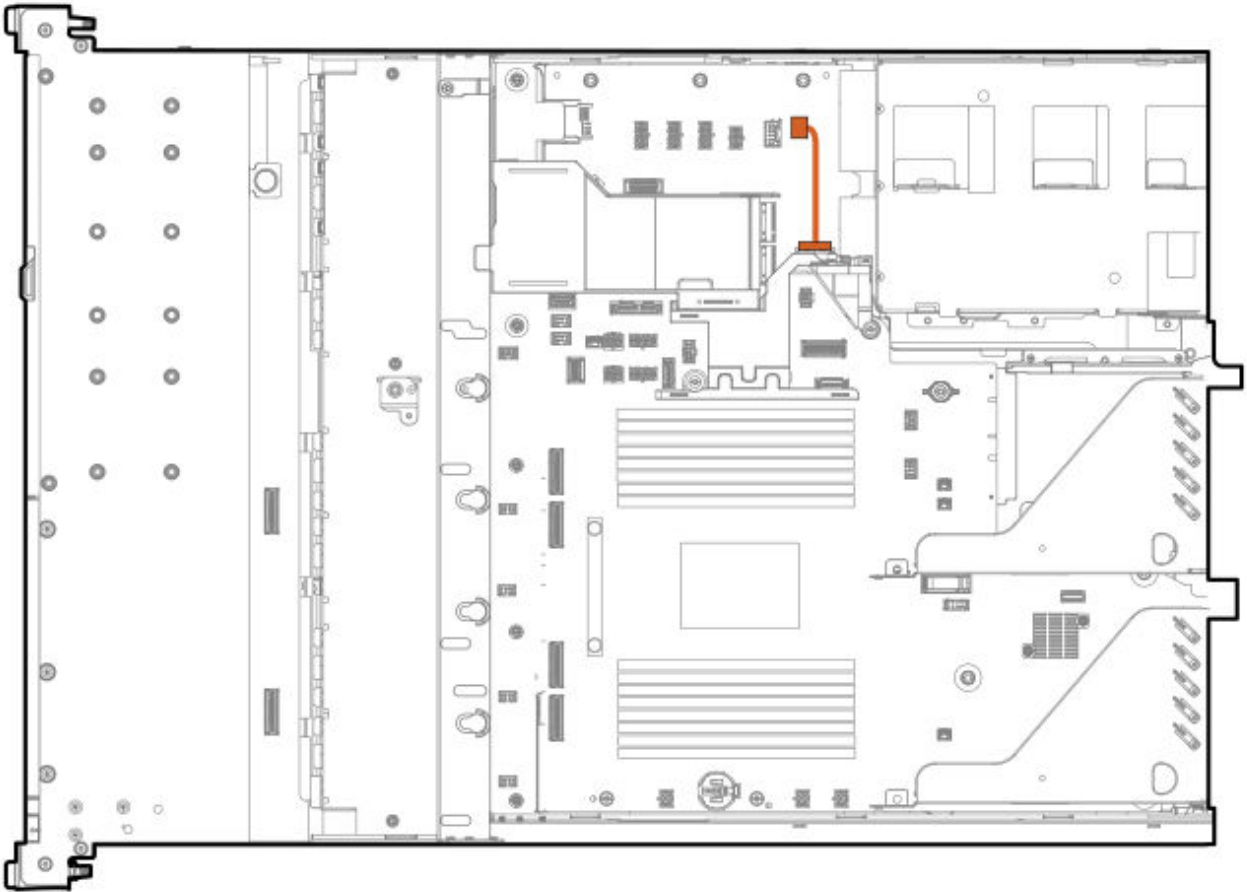

Cable part number	Color	From	To
869413-001 ¹ / ₁	Orange	Chassis intrusion switch	Chassis intrusion switch connector

¹/₁ Option kit: P55417-B21

Troubleshooting

Subtopics

[NMI functionality](#)

[Troubleshooting resources](#)

NMI functionality

An NMI crash dump enables administrators to create crash dump files when a system is not responding to traditional debugging methods.

An analysis of the crash dump log is an essential part of diagnosing reliability problems, such as hanging operating systems, device drivers, and applications. Many crashes freeze a system, and the only available action for administrators is to cycle the system power. Resetting the system erases any information that could support problem analysis, but the NMI feature preserves that information by performing a memory dump before a hard reset.

To force the OS to initiate the NMI handler and generate a crash dump log, the administrator can use the iLO Generate NMI feature.

Troubleshooting resources

Troubleshooting resources are available for HPE Gen11 server products in the following documents:

- Troubleshooting Guide for HPE ProLiant Gen11 servers provides procedures for resolving common problems and comprehensive courses of action for fault isolation and identification, issue resolution, and software maintenance.

<https://www.hpe.com/info/gen11-troubleshooting>

- Integrated Management Log Messages for HPE ProLiant Gen10, Gen10 Plus, and Gen11 servers and HPE Synergy provides IML messages and associated troubleshooting information to resolve critical and cautionary IML events.

<https://www.hpe.com/info/Troubleshooting-IML-en>

Safety, warranty, and regulatory information

Subtopics

[Regulatory information](#)

[Warranty information](#)

Regulatory information

To view the regulatory information for your product, view the Safety and Compliance Information for Server, Storage, Power, Networking, and Rack Products, available at the Hewlett Packard Enterprise Support Center:

<https://www.hpe.com/support/Safety-Compliance-EnterpriseProducts>

Additional regulatory information

Hewlett Packard Enterprise is committed to providing our customers with information about the chemical substances in our products as needed to comply with legal requirements such as REACH (Regulation EC No 1907/2006 of the European Parliament and the Council). A chemical information report for this product can be found at:

<https://www.hpe.com/info/reach>

For Hewlett Packard Enterprise product environmental and safety information and compliance data, including RoHS and REACH, see:

<https://www.hpe.com/info/ecodata>

For Hewlett Packard Enterprise environmental information, including company programs, product recycling, and energy efficiency, see:

<https://www.hpe.com/info/environment>

Subtopics

[Notices for Eurasian Economic Union](#)

[Turkey RoHS material content declaration](#)

[Ukraine RoHS material content declaration](#)

Notices for Eurasian Economic Union



Manufacturer and Local Representative Information

Manufacturer information:

Hewlett Packard Enterprise Company, 1701 E Mossy Oaks Road, Spring, TX 77389 U.S.

Local representative information Russian:

- **Russia**

ООО "Хьюлетт Паккард Энтерпрайз", Российская Федерация, 125171, г. Москва, Ленинградское шоссе, 16А, стр.3, Телефон: +7 499 403 4248 Факс: +7 499 403 4677

- **Kazakhstan**

ТОО «Хьюлетт-Паккард (К)», Республика Казахстан, 050040, г. Алматы, Бостандыкский район, проспект Аль-Фараби, 77/7, Телефон/факс: + 7 727 355 35 50

Local representative information Kazakh:

- **Russia**

ЖШС "Хьюлетт Паккард Энтерпрайз", Ресей Федерациясы, 125171, Мәскеу, Ленинград тас жолы, 16А блок 3, Телефон: +7 499 403 4248 Факс: +7 499 403 4677

- **Kazakhstan**

ЖШС «Хьюлетт-Паккард (К)», Қазақстан Республикасы, 050040, Алматы к., Бостандык ауданы, Әл-Фараби даңғылы, 77/7, Телефон/факс: +7 727 355 35 50

Manufacturing date:

The manufacturing date is defined by the serial number.

CCSYWWZZZZ (product serial number format)

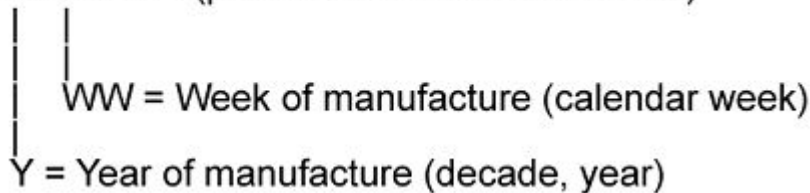

If you need help identifying the manufacturing date, contact tre@hpe.com.

Turkey RoHS material content declaration

Türkiye Cumhuriyeti: AEEE Yönetmeliğine Uygundur

Ukraine RoHS material content declaration

Обладнання відповідає вимогам Технічного регламенту щодо обмеження використання деяких небезпечних речовин в електричному та електронному обладнанні, затвердженого постановою Кабінету Міністрів України від 3 грудня 2008 № 1057

Warranty information

To view the warranty information for your product, see the [warranty check tool](#).

Specifications

Subtopics

[Environmental specifications](#)

[Mechanical specifications](#)

[Power supply specifications](#)

Environmental specifications

Specifications	Value
Temperature range	—
Operating	10°C to 35°C (50°F to 95°F)
Nonoperating	-30°C to 60°C (-22°F to 140°F)
Relative humidity (noncondensing)	—
Operating	8% to 90% 28°C (82.4°F) maximum wet bulb temperature, noncondensing
Nonoperating	5% to 95%

Specifications	Value
	38.7°C (101.7°F) maximum wet bulb temperature, noncondensing
Altitude	—
Operating	3050 m (10,000 ft) This value may be limited by the type and number of options installed. Maximum allowable altitude change rate is 457 m/min (1,500 ft/min).
Nonoperating	9144 m (30,000 ft) Maximum allowable altitude change rate is 457 m/min (1,500 ft/min).

Standard operating support

10° to 35°C (50° to 95°F) at sea level with an altitude derating of 1.0°C per every 305 m (1.8°F per every 1,000 ft) above sea level to a maximum of 3,050 m (10,000 ft), no direct sustained sunlight. Maximum rate of change is 20°C/hr (36°F/hr). The upper limit and rate of change may be limited by the type and number of options installed.

System performance during standard operating support might be reduced if operating above 30°C (86°F).

Extended ambient operating support

For approved hardware configurations, the supported system inlet range is extended to be:

- 5° to 10°C (41° to 50°F) and 35° to 40°C (95° to 104°F) at sea level with an altitude derating of 1.0°C per every 175 m (1.8°F per every 574 ft) above 900 m (2,953 ft) to a maximum of 3050 m (10,000 ft).
- 40°C to 45°C (104°F to 113°F) at sea level with an altitude derating of 1.0°C per every 125 m (1.8°F per every 410 ft) above 900 m (2,953 ft) to a maximum of 3,050 m (10,000 ft).

The approved hardware configurations for this system are listed in the Extended Ambient Temperature Guidelines for Gen11 HPE ProLiant servers:

<https://www.hpe.com/support/ASHRAEGen11>

Mechanical specifications

Specification	Value
SFF	—
Height	4.28 cm (1.69 in)
Depth	60.52 cm (23.83 in)
Width	43.46 cm (17.11 in)

Specification	Value
Weight, minimum	12.00 kg (26.45 lb)
Weight, maximum	16.7 kg (36.81 lb)
4 LFF	—
Height	4.28 cm (1.69 in)
Depth	66.47 cm (26.17 in)
Width	43.46 cm (17.11 in)
Weight, minimum	13.20 kg (29.10 lb)
Weight, maximum	17.70 kg (39.02 lb)
12 LFF	—
Height	4.28 cm (1.69 in)
Depth	99.51 cm (39.18 in)
Width	43.46 cm (17.11 in)
Weight, minimum	18.60 kg (41.00 lb)
Weight, maximum	29.60 kg (65.23 lb)
GPU dense	—
Height	4.28 cm (1.69 in)
Depth	77.42 cm (30.48 in)
Width	43.46 cm (17.11 in)
Weight, minimum	14.70 kg (32.41 lb)
Weight, maximum	20.90 kg (46.08 lb)

Power supply specifications

Depending on the installed options and the regional location where the server was purchased, the server can be configured with one of the following power supplies. For detailed power supply specifications, see the QuickSpecs on the [Hewlett Packard Enterprise website](#).

Subtopics

[**HPE 500 W Flex Slot Platinum Hot-plug Low Halogen Power Supply**](#)

[**HPE 800 W Flex Slot Platinum Hot-plug Low Halogen Power Supply**](#)

[**HPE 1000 W Flex Slot Titanium Hot-plug Power Supply**](#)

[**HPE 1600 W Flex Slot -48 VDC Hot-plug Power Supply**](#)

HPE 500 W Flex Slot Platinum Hot-plug Low Halogen Power Supply

Specification	Value
Input requirements	—
Rated input voltage	100 VAC to 240 VAC 240 VDC for China
Rated input frequency	50 Hz to 60 Hz Not applicable to 240 VDC
Rated input current	5.8 A at 100 VAC 2.8 A at 200 VAC 2.4 A at 240 VDC for China
Maximum rated input power	580 W at 100 VAC 560 W at 200 VAC 558 W at 240 VDC for China
BTUs per hour	1999 at 100 VAC 1912 at 200 VAC 1904 at 240 VDC for China
Power supply output	—
Rated steady-state power	500 W at 100 VAC to 127 VAC input 500 W at 100 VAC to 240 VAC input 500 W at 240 VDC input for China
Maximum peak power	500 W at 100 VAC to 127 VAC input 500 W at 100 VAC to 240 VAC input 500 W at 240 VDC input for China

HPE 800 W Flex Slot Platinum Hot-plug Low Halogen Power Supply

Specification	Value
Input requirements	—
Rated input voltage	100 VAC to 127 VAC 200 VAC to 240 VAC 240 VDC for China only
Rated input frequency	50 Hz to 60 Hz Not applicable to 240 VDC
Rated input current	9.4 A at 100 VAC 4.5 A at 200 VAC 3.8 A at 240 VDC for China only
Maximum rated input power	940 W at 100 VAC 900 W at 200 VAC 897 W at 240 VDC for China only
BTUs per hour	3067 at 100 VAC 2958 at 200 VAC 2949 at 240 VAC for China only
Power supply output	—
Rated steady-state power	800 W at 100 VAC to 127 VAC input 800 W at 100 VAC to 240 VAC input 800 W at 240 VDC input for China only
Maximum peak power	800 W at 100 VAC to 127 VAC input 800 W at 100 VAC to 240 VAC input 800 W at 240 VDC input for China only

HPE 1000 W Flex Slot Titanium Hot-plug Power Supply

Specification	Value
Input requirements	—
Rated input voltage	100 VAC to 127 VAC 200 VAC to 240 VAC 240 VDC for China
Rated input frequency	50 Hz to 60 Hz
Rated input current	11.3 A at 100 VAC 6.1 A at 200 VAC
Maximum rated input power	1130 W at 100 VAC 1090 W at 200 VAC
BTUs per hour	3764 at 100 VAC 3629 at 200 VAC
Power supply output	—
Rated steady-state power	1000 W at 100 VAC to 127 VAC 1000 W at 200 VAC to 240 VAC input
Maximum peak power	1000 W at 100 VAC to 127 VAC 1000 W at 200 VAC to 240 VAC

HPE 1600 W Flex Slot -48 VDC Hot-plug Power Supply

Specification	Value
Input requirements	—
Rated input voltage	-40 VDC to -72 VDC
Rated input frequency	DC
Nominal input current	45 A DC at -40 VDC input

Specification	Value
	36.6 A DC at -48 VDC input
	24.4 A DC at -72 VDC input
Maximum Rated Input Wattage Rating	1798 W at -40 VDC input
	1758 W at -48 VDC input
	1755 W at -72 VDC input
BTUs per hour	6026 at -40 VDC input
	6000 at -48 VDC input
	5989 at -72 VDC input
Power supply output	—
Rated steady-state power	1600 W at -40 VDC to -72 VDC
Maximum peak power	1600 W at -40 VDC to -72 VDC

Websites

General websites

Single Point of Connectivity Knowledge (SPOCK) Storage compatibility matrix

<https://www.hpe.com/storage/spock>

Product white papers and analyst reports

<https://www.hpe.com/us/en/resource-library>

For additional websites, see [Support and other resources](#).

Product websites

HPE ProLiant DL320 Gen11 Server user documents

<https://www.hpe.com/info/dl320gen11-docs>

Support and other resources

Subtopics

Accessing Hewlett Packard Enterprise Support

HPE product registration

Accessing updates

Customer self repair

Remote support

Documentation feedback

Accessing Hewlett Packard Enterprise Support

- For live assistance, go to the Contact Hewlett Packard Enterprise Worldwide website:

<https://www.hpe.com/info/assistance>

- To access documentation and support services, go to the Hewlett Packard Enterprise Support Center website:

<https://www.hpe.com/support/hpesc>

Information to collect

- Technical support registration number (if applicable)
- Product name, model or version, and serial number
- Operating system name and version
- Firmware version
- Error messages
- Product-specific reports and logs
- Add-on products or components
- Third-party products or components

HPE product registration

To gain the full benefits of the Hewlett Packard Enterprise Support Center and your purchased support services, add your contracts and products to your account on the HPESC.

- When you add your contracts and products, you receive enhanced personalization, workspace alerts, insights through the dashboards, and easier management of your environment.

- You will also receive recommendations and tailored product knowledge to self-solve any issues, as well as streamlined case creation for faster time to resolution when you must create a case.

To learn how to add your contracts and products, see <https://www.hpe.com/info/add-products-contracts>.

Accessing updates

- Some software products provide a mechanism for accessing software updates through the product interface. Review your product documentation to identify the recommended software update method.
- To download product updates:

Hewlett Packard Enterprise Support Center

<https://www.hpe.com/support/hpesc>

My HPE Software Center

<https://www.hpe.com/software/hpesoftwarecenter>

- To subscribe to eNewsletters and alerts:

<https://www.hpe.com/support/e-updates>

- To view and update your entitlements, and to link your contracts and warranties with your profile, go to the Hewlett Packard Enterprise Support Center **More Information on Access to Support Materials** page:

<https://www.hpe.com/support/AccessToSupportMaterials>



IMPORTANT

Access to some updates might require product entitlement when accessed through the Hewlett Packard Enterprise Support Center. You must have an HPE Account set up with relevant entitlements.

Customer self repair

Hewlett Packard Enterprise customer self repair (CSR) programs allow you to repair your product. If a CSR part needs to be replaced, it will be shipped directly to you so that you can install it at your convenience. Some parts do not qualify for CSR.

For more information about CSR, contact your local service provider.

Remote support

Remote support is available with supported devices as part of your warranty or contractual support agreement. It provides intelligent event diagnosis, and automatic, secure submission of hardware event notifications to Hewlett Packard Enterprise, which initiates a fast and accurate resolution based on the service level of your product. Hewlett Packard Enterprise strongly recommends that you register your device for remote support.

If your product includes additional remote support details, use search to locate that information.

HPE Get Connected

<https://www.hpe.com/services/getconnected>

HPE Tech Care Service

<https://www.hpe.com/services/techcare>

HPE Complete Care Service

<https://www.hpe.com/services/completercare>

Documentation feedback

Hewlett Packard Enterprise is committed to providing documentation that meets your needs. To help us improve the documentation, click the **Feedback** button on the page of an opened document on the Hewlett Packard Enterprise Support Center portal (<https://www.hpe.com/support/hpesc>). Use this feature to send any errors, suggestions, or comments. This process captures all document information.