



- U.S.A. : **KUBOTA TRACTOR CORPORATION**  
3401 Del Amo Blvd., Torrance, CA 90503, U.S.A.  
Telephone : (310)370-3370
- Western Division : 1175 S. Guild Avc., Lodi, CA 95240  
Telephone : (209)334-9910
- Central Division : 14855 FAA Blvd., Fort Worth, TX 76155  
Telephone : (817)571-0900
- Northern Division : 6300 at One Kubota Way, Groveport, OH 43125  
Telephone : (614)835-1100
- Southeast Division : 1025 Northbrook Parkway, Suwanee, GA 30024  
Telephone : (770)995-8855
- Canada : **KUBOTA CANADA LTD.**  
5900 14th Avenue, Markham, Ontario, L3S 4K4, Canada  
Telephone : (905)294-7477
- France : **KUBOTA EUROPE S.A.S**  
19-25, Rue Jules Vercey, Z.I. BP88, 95101 Argenteuil Cedex, France  
Telephone : (33)1-3426-3434
- Italy : **KUBOTA EUROPE S.A.S Italy Branch**  
Via Grandi, 29 20068 Peschiera Borrome (MI) Italy  
Telephone : (39)02-51650377
- Germany : **KUBOTA (DEUTSCHLAND) GmbH**  
Senefelder Str. 3-5 63110 Rodgau /Nieder-Roden, Germany  
Telephone : (49)6106-873-0
- U.K. : **KUBOTA (U.K.) LTD.**  
Dormer Road, Thame, Oxfordshire, OX9 3UN, U.K.  
Telephone : (44)1844-214500
- Spain : **KUBOTA ESPAÑA S.A.**  
Avenida Recomba No.5, Poligno Industrial la Laguna, Leganes, 28914 (Madrid) Spain  
Telephone : (34)91-508-6442
- Australia : **KUBOTA TRACTOR AUSTRALIA PTY LTD.**  
25-29 Permas Way, Truganina, VIC 3029, Australia  
Telephone : (61)-3-9394-4400
- Malaysia : **SIME KUBOTA SDN. BHD.**  
No.3 Jalan Sepadu 25/123 Taman Perindustrian Axis,  
Seksyen 25, 40400 Shah Alam, Selangor Darul Ehsan Malaysia  
Telephone : (60)3-736-1388
- Philippines : **KUBOTA PHILIPPINES, INC.**  
155 Panay Avenue, South Triangle Homes, 1103 Quezon City, Philippines  
Telephone : (63)2-9201071
- Taiwan : **SHIN TAIWAN AGRICULTURAL MACHINERY CO., LTD.**  
16, Fengping 2nd Rd, Taliao Shiang Kaohsiung 83107, Taiwan R.O.C.  
Telephone : (886)7-702-2333
- Indonesia : **PT KUBOTA MACHINERY INDONESIA**  
Tower A at EightyEight@Kasablanka Lantai 16  
Jalan Raya Casablanka Kav. 88, Jakarta 12870 Indonesia  
Telephone : (62)-21-29568-720
- Thailand : **SIAM KUBOTA CORPORATION CO., LTD.**  
101/19-24 Moo 20, Navanakorn Industrial Estate, Tambon Khlongnueng, Amphur Khlongluang,  
Pathumthani 12120, THAILAND  
Telephone : (66)2-909-0300
- Korea : **KUBOTA KOREA CO., LTD.**  
106-24 Mongsan-Ri, Mankyung-Up, Kimje-City, Chonrapuk-Do, KOREA  
Telephone : (82)-63-544-5822
- India : **KUBOTA AGRICULTURAL MACHINERY INDIA PVT. LTD.**  
Regus, Level 2 Altius, Olympia Tech Park, No.1 SIDCO Industrial Estate, Guindy, Chennai 600032, TN, India  
Telephone : (91)-44-4299-4237
- Vietnam : **KUBOTA VIETNAM CO., LTD.**  
Lot B-3A2-CN, My Phuoc 3 Industrial Park, Ben Cat District, Binh Duong Province, Vietnam  
Telephone : (84)-650-3577-507

KUBOTA Corporation

English (U.S.A)  
Code No. 7J294-6911-2

AS. G. 2-2 . -. K

# OPERATOR'S MANUAL

# KUBOTA FRONT LOADER

MODEL LA525

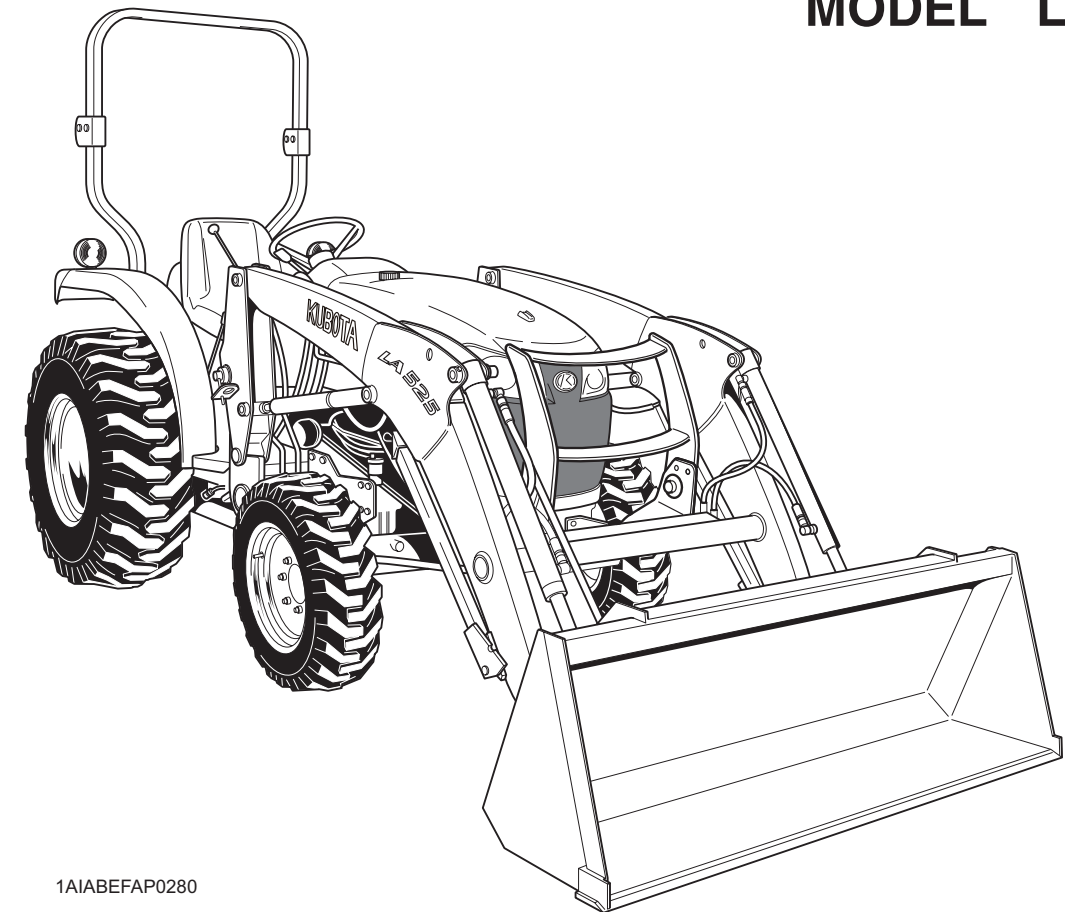

1A1ABEFAP0280

L  
A  
5  
2  
5

READ AND SAVE THIS MANUAL



# ABBREVIATION LIST

Abbreviations	Definitions
2WD	2-Wheel Drive
4WD	4-Wheel Drive
API	American Petroleum Institute
ASABE	American Society of Agricultural and Biological Engineers, USA
ASTM	American Society of Testing and Materials, USA
DIN	Deutsches Institut für Normung, GERMANY
DT	Dual Traction [4WD]
fpm	Feet Per Minute
GST	Glide Shift Transmission
Hi-Lo	High Speed-Low Speed
HST	Hydrostatic Transmission
m/s	Meters Per Second
PTO	Power Take Off
RH/LH	Right-hand and left-hand sides are determined by facing in the direction of forward travel
ROPS	Roll-Over Protective Structures
rpm	Revolutions Per Minute
r/s	Revolutions Per Second
SAE	Society of Automotive Engineers, USA
SMV	Slow Moving Vehicle

# FOREWORD

You are now the proud owner of a KUBOTA Loader. This loader is a product of KUBOTA quality engineering and manufacturing. It is made of fine materials and under a rigid quality control system. It will give you long, satisfactory service. To obtain the best use of your loader, please read this manual carefully. If your tractor is provided with CAB, also read the CAB operator's manual, which is a separate manual. It will help you become familiar with the operation of the loader and contains many helpful hints about loader maintenance. It is KUBOTA's policy to utilize as quickly as possible every advance in our research. The immediate use of new techniques in the manufacture of products may cause some small parts of this manual to be outdated. KUBOTA distributors and dealers will have the most up-to-date information. Please do not hesitate to consult with them.



## SAFETY FIRST

This symbol, the industry's "Safety Alert Symbol", is used throughout this manual and on labels on the mower itself to warn of the possibility of personal injury. Read these instructions carefully. It is essential that you read the instructions and safety regulations before you attempt to assemble or use this unit.



**DANGER :** Indicates an imminently hazardous situation which, if not avoided, will result in death or serious injury.



**WARNING :** Indicates a potentially hazardous situation which, if not avoided, could result in death or serious injury.



**CAUTION :** Indicates a potentially hazardous situation which, if not avoided, could result in minor or moderate injury.

**IMPORTANT :** Indicates that equipment or property damage could result if instructions are not followed.

**NOTE :** Gives helpful information.



# CONTENTS

- ▲ SAFE OPERATION ..... ▲-1
- SERVICING OF LOADER ..... 1
- SPECIFICATIONS ..... 2
  - SUITABLE TRACTOR ..... 2
  - LOADER SPECIFICATIONS ..... 2
  - BUCKET SPECIFICATIONS ..... 3
  - DIMENSIONAL SPECIFICATIONS ..... 3
  - OPERATIONAL SPECIFICATIONS ..... 4
  - LOADER TERMINOLOGY ..... 6
- PRE-OPERATION CHECK ..... 7
  - LUBRICATION ..... 7
  - TRANSMISSION FLUID ..... 7
  - TREAD ..... 8
  - REAR BALLAST ..... 8
    - Liquid ballast in rear tires ..... 8
  - TIRE INFLATION ..... 9
    - Inflation pressure ..... 9
- TEST OPERATION ..... 9
  - REMOVING AIR FROM THE HYDRAULIC SYSTEM ..... 9
- OPERATING THE LOADER ..... 10
  - FILLING THE BUCKET ..... 10
  - LIFTING THE LOAD ..... 10
  - CARRYING THE LOAD ..... 11
  - DUMPING THE BUCKET ..... 11
  - LOWERING THE BUCKET ..... 11
  - OPERATING WITH FLOAT CONTROL ..... 11
  - LOADING FROM A BANK ..... 12
  - PEELING AND SCRAPING ..... 12
  - LOADING LOW TRUCKS OR SPREADERS FROM A PILE ..... 13
  - BACKFILLING ..... 13
  - HANDLING LARGE HEAVY OBJECTS ..... 14
  - VALVE LOCK ..... 14
    - Standard valve ..... 14
  - FRONT GUARD ..... 15
  - BUCKET LEVEL INDICATOR (if equipped) ..... 15
  - ATTACHING ATTACHMENTS (if equipped) ..... 16
  - DETACHING ATTACHMENTS ..... 17
  - DISMOUNTING THE LOADER ..... 18
- MAINTENANCE ..... 18
- ATTACHMENTS ..... 18
  - Quick attach bucket ..... 18
  - Bale spear ..... 18
  - Pallet fork ..... 19

---

ASSEMBLE PALLET FORK .....	19
MAINTENANCE.....	20
LUBRICATION .....	20
RE-TIGHTENING OF HARDWARE .....	20
DAILY CHECKS.....	21
EVERY 50 HOURS .....	21
Checking main frame bolt torque.....	21
General torque specification .....	22
REMOVING THE LOADER .....	23
STORING THE LOADER .....	25
REINSTALLING THE LOADER.....	26



# SAFE OPERATION

Most loader equipment accidents can be avoided by following simple safety precautions. These safety precautions, if followed at all times, will help you operate your loader safely.

## 1. BEFORE OPERATING THE LOADER

1. Know your equipment and its limitations.  
Allow only trained personnel to operate or service this equipment.
2. Read and understand all instructions and precautions found in both the tractor and the loader operator's manuals before using the loader.  
Lack of knowledge can lead to accidents.
3. It is the owner's responsibility to ensure that anyone who will operate the loader reads this manual first and becomes familiar with the safe operation of the loader.
4. For your safety, a ROPS with a seat belt is strongly recommended by KUBOTA in almost all applications.  
If your tractor has a foldable ROPS, fold it down only when absolutely necessary and raise it up and lock it again as soon as possible. Do not wear the seat belt when a foldable ROPS is down or a fixed ROPS is removed. If you have any questions, consult your local KUBOTA dealer.  
Always use the seat belt when the tractor is equipped with a ROPS. Never use the seat belt when the tractor is not equipped with a ROPS.
5. Visually check for hydraulic leaks and broken, missing, or malfunctioning parts.  
Make necessary repairs before operating.
6. Replace damaged or illegible safety labels. See following pages for required labels.
7. When the front loader is mounted on the tractor, enter and exit the operator's seat only from left side of the tractor.
8. Engage the loader control valve lock to prevent accidental actuation when the implement is not in use or during transport. Do not utilize the valve lock for machine maintenance or repair.
9. Assemble, remove and reinstall the loader only as directed in this manual. Failure to do this could result in serious personal injury or death.

10. Follow the precautions below when attaching attachments.

- Make sure both handles (LH, RH) contact the ear plates at the points (A) and are all the way down.
- Make sure both lock pins (LH, RH) protrude through the pin slots.
- Kubota recommends the use of Kubota attachments on Kubota loaders. Non-Kubota attachments, if used, must comply with ISO 24410, first edition 2005-04-15.
- Use of a non-Kubota attachment that does not comply with ISO 24410 or the improper positioning of handle(s) or non-protrusion of pin(s) may result in detachment of the attachment or deformation, causing loss of performance, personal injury or death.

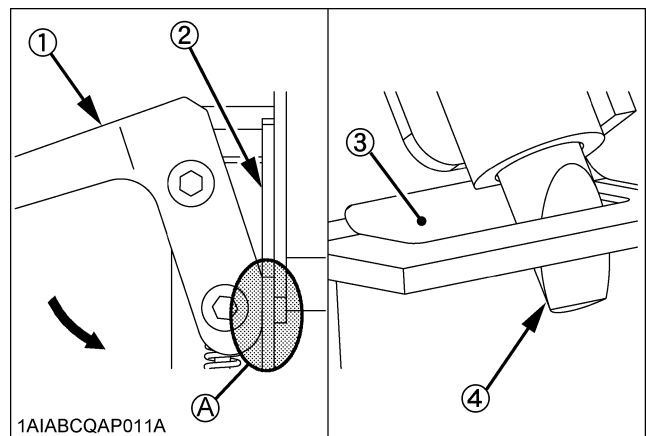

- (1) Handle  
(2) Ear plate  
(3) Pin slot  
(4) Lock pin

(A) The handle contacts the ear plate at the points.

## 2. OPERATING THE LOADER

1. Operate the loader only when properly seated at the controls. Do not operate from the ground.
2. Move and turn the tractor at low speeds.
3. Never allow anyone to get under the loader bucket or reach through the boom when the bucket is raised.
4. Keep children, others and livestock away when operating loader and tractor.
5. Do not walk or work under a raised loader bucket or attachment unless it is securely blocked and held in position.
6. For tractor stability and operator safety, rear ballast must be added to the 3-point hitch and to the rear wheels when using loader.
7. To increase stability adjust the rear wheels to the widest setting that is suitable for your application.
8. Exercise extra caution when operating the loader with a raised bucket or attachment.
9. Do not lift or carry any person on the loader, in the bucket, or other attachment.
10. Avoid loose fill, rocks and holes. They can be dangerous for loader operation or movement.
11. Avoid overhead wires and obstacles when the loader is raised. Contacting electric lines can cause electrocution.
12. Gradually stop the loader boom when lowering or lifting.
13. Use caution when handling loose or shiftable loads.
14. Using loaders for handling large, heavy, or shiftable objects is not recommended without proper handling attachments.
15. Handling large heavy objects can be extremely dangerous due to :
  - Danger of rolling the tractor over.
  - Danger of upending the tractor.
  - Danger of the object rolling or sliding down the loader boom onto the operator.
16. If you must perform this sort of work (item 15), protect yourself by :
  - Never lift the load higher than necessary to clear the ground.
  - Add rear ballast to the tractor to compensate for the load or use rear implement.
  - Never lift large objects with equipment that may permit them to roll back onto the operator.
  - Move slowly and carefully, avoiding rough terrain.
17. Never lift or pull a load from any point on the loader with a chain, rope, or cable. Doing so could cause a rollover or serious damage to the loader.
18. Be extra careful when operating the tractor on a slope, always operate up and down, never across the slope. Do not operate on steep slopes or unstable surfaces.
19. When operating another implement on a hillside, be sure to remove the loader to reduce the risk of rollover.
20. Carry loader boom at a low position during transport. (You should be able to see over the bucket.)

21. Allow for the loader length when making turns.

## 3. AFTER OPERATING THE LOADER

1. When loader work is complete and parking or storing, choose flat and hard ground. Lower the loader boom to the ground, stop the engine, set the brakes and remove the key before leaving the tractor seat.
2. Make sure the detached loader is on stands and on a hard, level surface.
3. Before disconnecting hydraulic lines, relieve all hydraulic pressure by moving the controls.
4. Do not remove the loader from the tractor without an approved bucket attached.

## 4. SERVICING THE LOADER

1. Always wear safety goggles when servicing or repairing the machine.
2. Do not modify the loader. Unauthorized modification may affect the function of the loader, which may result in personal injury.
3. Do not use the loader as a work platform or a jack to support the tractor for servicing or maintenance. Securely support the tractor or any machine elements with stands or suitable blocking before working underneath.

For your safety, do not work under any hydraulically supported devices. They can settle or suddenly leak down or be accidentally lowered.
4. Escaping hydraulic oil under pressure can have sufficient force to penetrate the skin, causing serious personal injury. Do not use hands to search for suspected leaks. If injured by escaping fluid, obtain medical treatment immediately.
5. Do not tamper with the relief valve setting. The relief valve is pre-set at the factory. Changing the setting can cause overloading of the loader and tractor which may result in serious personal injury.
6. When servicing or replacing pins in cylinder ends, bucket, etc., always use a brass drift and hammer. Failure to do so could result in injury from flying metal fragments.



**DANGER,WARNING AND CAUTION LABELS**

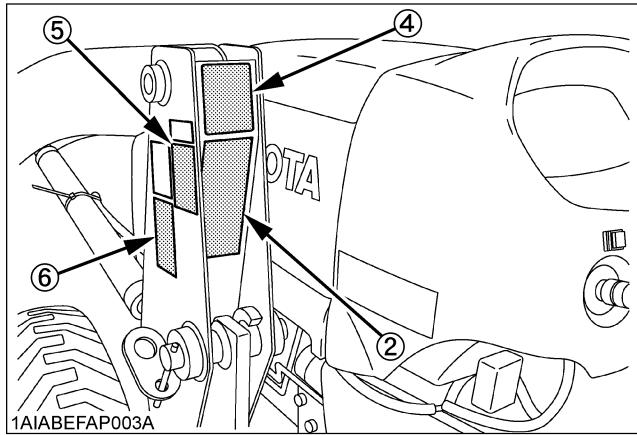

(1) Part No. 7J246-5643-1

**▲ DANGER**

**TO AVOID SERIOUS INJURY OR DEATH CAUSED BY FALLING LOADS :**

1. Load on raised bucket or fork can fall or roll back onto operator causing serious injury or death.
2. Use approved clamping and / or guard attachments for handling large, loose or shiftable loads such as bales, posts, sheets of plywood etc.
3. Carry loads as low as possible.

1AIABAHAP016A

(2) Part No. 7J246-5641-1

**▲ DANGER**

**TO AVOID SERIOUS INJURY OR DEATH CAUSED BY ROLLOVERS :**

1. ROPS and a fastened seat belt are strongly recommended in almost all applications. Foldable ROPS should be in upright and locked position if equipped.
2. Adjust rear wheels to the widest setting that is suitable for the work.
3. Add recommended wheel ballast and rear weight for stability.
4. DO NOT drive on steep slopes or unstable surfaces.
5. Carry loader arms at low position during transport. Move and turn tractor at slow speeds.

1AIABAHAP017A

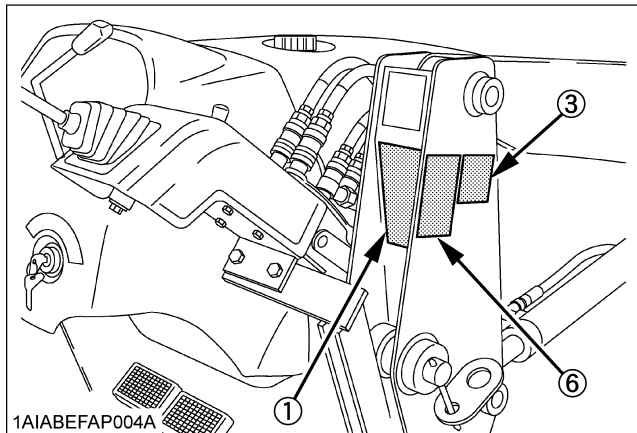

(5) Part No. 7J246-5645-1

**▲ CAUTION**

**TO AVOID PERSONAL INJURY :**

1. Observe safety precautions in loader and tractor Operator's Manual.
2. Operate the loader from tractor seat only.
3. Keep children, others and livestock away when operating loader and tractor.
4. Avoid holes, loose ground, and rocks which may cause tractor / loader to tip.
5. Make sure approved bucket is attached before removing loader from tractor.
6. When parking or storing, choose flat and hard ground. Lower the bucket to the ground, set brakes and remove key before leaving tractor.
7. Before disconnecting hydraulic lines, relieve all hydraulic pressure.

1AIABAHAP019A

(6) Part No. 7J246-5644-2 (Both sides)

**▲ WARNING**

**TO AVOID INJURY FROM FALLS OR BEING CRUSHED :**

1. DO NOT stand or work under raised loader or bucket.
2. DO NOT use loader as jack for servicing.
3. DO NOT use loader as a work platform.
4. NEVER connect chain, cable or rope to loader bucket while operating loader.

1AIABAHAP020A

(3) Part No. 7J266-5649-2

**▲ CAUTION**

**TO AVOID INJURY FROM CRUSHING :**

1. Do not utilize the valve lock for machine maintenance or repair.
2. The valve lock is to prevent accidental actuation when implement is not in use or during transport.

1AIABACAP077A

(4) Part No. 7J246-5642-1

**▲ DANGER**

**TO AVOID SERIOUS INJURY OR DEATH CAUSED BY CONTACT WITH ELECTRIC LINES:**

- Check overhead clearance.

1AIABAHAP018A

[Bale spear]

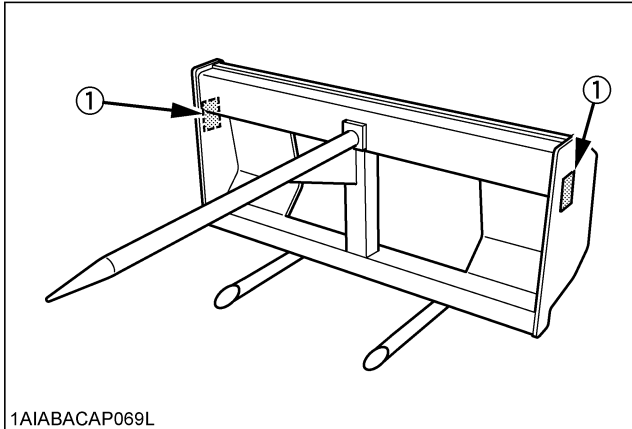

[Pallet fork]

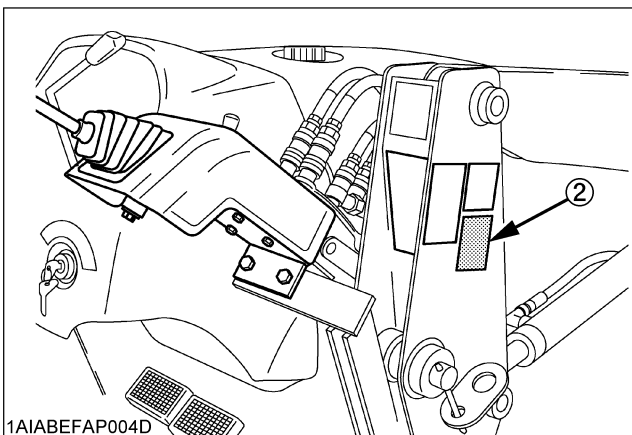
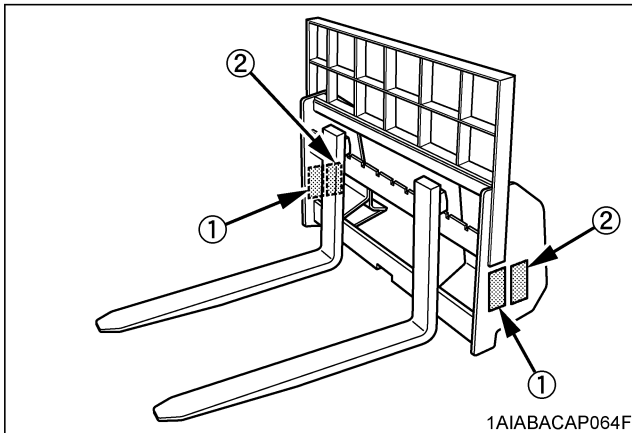

(1) Part No. 7J246-5643-1  
(Both sides)

**▲ DANGER**

**TO AVOID SERIOUS INJURY OR DEATH CAUSED BY FALLING LOADS :**

1. Load on raised bucket or fork can fall or roll back onto operator causing serious injury or death.
2. Use approved clamping and / or guard attachments for handling large, loose or shiftable loads such as bales, posts, sheets of plywood etc.
3. Carry loads as low as possible.

1AIABACAP075A

(2) Part No. 7J293-3923-1

**▲ DANGER**

**PALLET FORK SPECIFICATION**

- Rated capacity
 

LA853, LA854, LA844, LA1055, LA1065	: 1300 LBS. (590 kg)
LA703A, LA723, LA724, LA714, LA764, LA765, LA805	: 1000 LBS. (454 kg)
LA754N	: 925 LBS. (420 kg)
LA513, LA514, TL500, LA555	: 800 LBS. (363 kg)
LA463, LA524, LA525	: 710 LBS. (322 kg)
- The distance to its center of gravity from the attachment face
 

LA853, LA854, LA844, LA1065	: 22.6in(575 mm)
LA703A, LA723, LA724, LA714, LA784, LA785, LA754N, LA513, LA514, TL500, LA463, LA524, LA525	: 19.6in(498 mm)
- The weight of the attachment (not including tines) : 203 LBS. (92 kg)

**TO AVOID PERSONAL INJURY OR DEATH CAUSED BY ROLLOVER**

- Do not exceed rated load listed above.
- Use rear implement and tire ballast recommended in loader operator's manual.
- Operate tractor slowly taking special care when turning.

1AIABEFAP031E

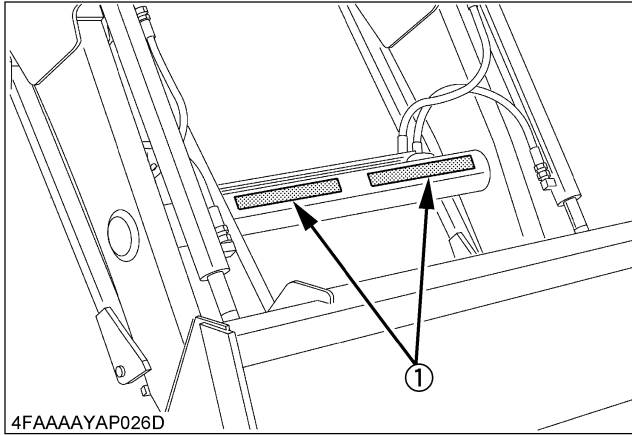

(1) Part No. 7J802-3648-5 [If the loader is equipped with quick attach coupler]

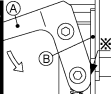
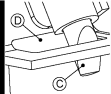
<b>▲ DANGER</b>			
TO AVOID PERSONAL INJURY OR DEATH			
<p>1. Make sure both handles (LH, RH) <b>A</b> contact the ear plates <b>B</b> at the X points and are all the way down.</p> 	<p>2. Make sure both lock pins (LH, RH) <b>C</b> protrude through the pin slots <b>D</b>.</p> 	<p>Kubota recommends the use of Kubota attachments on Kubota loaders. Non-Kubota attachments, if used, must comply with ISO 24410, first edition 2005-04-15.</p>	<p>Use of a non-Kubota attachment that does not comply with ISO 24410 or the improper positioning of handle(s) or non-protrusion of pin(s) may result in detachment of the attachment or deformation, causing loss of performance, personal injury or death.</p>
<p><b>A</b> HANDLE <b>B</b> EAR PLATE <b>C</b> LOCK PIN <b>D</b> PIN SLOT</p>		<p>For information contact your Kubota Dealer</p>	

1A1ABAAAP119A

### CARE OF DANGER, WARNING AND CAUTION LABELS

1. Keep danger, warning and caution labels clean and free from obstructing material.
2. Clean danger, warning and caution labels with soap and water, dry with a soft cloth.
3. Replace damaged or missing danger, warning and caution labels with new labels from your local KUBOTA dealer.
4. If a component with danger, warning and caution label (s) affixed is replaced with new part, make sure new label (s) is (are) attached in the same location (s) as the replaced component.
5. Mount new danger, warning and caution labels by applying on a clean dry surface and pressing any bubbles to outside edge.



# SERVICING OF LOADER

Your dealer is interested in your new loader and has the desire to help you get the most value from it. After reading this manual thoroughly, you will find that you can do some of the regular maintenance yourself.

However, when in need of parts or major service, be sure to see your KUBOTA dealer.

For service, contact the KUBOTA dealership from which you purchased your loader or your local KUBOTA dealer.

When in need of parts, be prepared to give your dealer the loader serial number.

Locate the serial numbers now and record them in the space provided.

KUBOTA LOADER
Model
Serial Number
Date of Purchase
Name of Dealer
(To be filled in by purchaser)

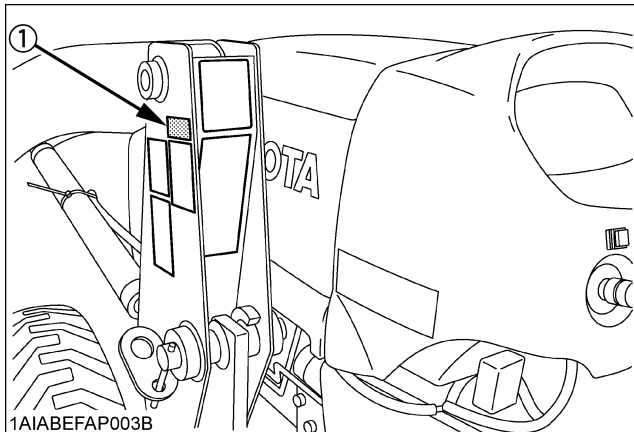

1A1ABEFAP003B  
(1) Serial number

# SPECIFICATIONS

## SUITABLE TRACTOR

LA525: L2501, L3301, L3901

## LOADER SPECIFICATIONS

LOADER MODEL		LA525	
TRACTOR MODEL		L2501	L3301, L3901
WHEEL BASE(WB)	mm (in.)	1610 (63.3)	
FRONT TIRES		7 - 16	
REAR TIRES		11.2 - 24	
BOOM CYLINDER	BORE mm (in.)	45 (1.77)	
	STROKE mm (in.)	476 (18.7)	
BUCKET CYLINDER	BORE mm (in.)	45 (1.77)	
	STROKE mm (in.)	476 (18.7)	
CONTROL VALVE	3 Position bucket control valve type	One Detent Float Position, Regenerative Bucket Dump, Power Beyond Circuit	
RATED FLOW	L/min (GPM)	23.9 (6.3)	
MAXIMUM PRESSURE	MPa (kg/cm <sup>2</sup> , psi)	15.7 (160, 2275)	16.2 (165, 2347)
NET WEIGHT(APPROXIMATE)	kg (lbs.)	365 (805)	

## BUCKET SPECIFICATIONS

LOADER MODEL		LA525	
MODEL		SQUARE 60"	SQUARE 66"
TYPE		RIGID	QUICK ATTACH
WIDTH	mm (in.)	1525 (60)	1675 (66)
DEPTH (L)	mm (in.)	463 (18.2)	458 (18)
HEIGHT (M)	mm (in.)	559 (22)	562 (22.1)
LENGTH (N)	mm (in.)	511 (20.1)	544 (21.4)
CAPACITY	STRUCK m <sup>3</sup> (CU.FT.)	0.22 (7.8)	0.23 (8.1)
	HEAPED m <sup>3</sup> (CU.FT.)	0.26 (9.2)	0.28 (9.9)
WEIGHT	kg (lbs.)	82 (181)	120 (265)

## DIMENSIONAL SPECIFICATIONS

	LOADER MODEL		LA525
	TRACTOR MODEL		L2501, L3301, L3901
	BUCKET TYPE		RIGID
A	MAX. LIFT HEIGHT (TO BUCKET PIVOT PIN)	mm (in.)	2394 (94.3)
B	MAX. LIFT HEIGHT UNDER LEVEL BUCKET	mm (in.)	2224 (87.6)
C	CLEARANCE WITH BUCKET DUMPED	mm (in.)	1936 (76.2)
D	REACH AT MAX. LIFT HEIGHT (DUMPING REACH)	mm (in.)	645 (25.4)
E	MAX. DUMP ANGLE	deg.	40
F	REACH WITH BUCKET ON GROUND	mm (in.)	1618 (63.7)
G	BUCKET ROLL-BACK ANGLE	deg.	31
H	DIGGING DEPTH	mm (in.)	176 (6.9)
J	OVERALL HEIGHT IN CARRYING POSITION	mm (in.)	1302 (51.3)

# OPERATIONAL SPECIFICATIONS

LOADER MODEL			LA525	
TRACTOR MODEL			L2501	L3301, L3901
BUCKET TYPE			RIGID	
U	LIFT CAPACITY (BUCKET PIVOT PIN, MAX. HEIGHT)	kg (lbs.)	491 (1082)	513 (1131)
V	LIFT CAPACITY (500 mm FORWARD, MAX. HEIGHT)	kg (lbs.)	372 (820)	388 (855)
W	LIFT CAPACITY (BUCKET PIVOT PIN, 1500 mm HEIGHT)	kg (lbs.)	649 (1431)	676 (1490)
X	LIFT CAPACITY (500 mm FORWARD, 1500 mm HEIGHT)	kg (lbs.)	515 (1135)	536 (1182)
Y	BREAKOUT FORCE (BUCKET PIVOT PIN)	N (lbf.)	10554 (2373)	10951 (2462)
Z	BREAKOUT FORCE (500mm FORWARD)	N (lbf.)	8033 (1806)	8335 (1874)
VV	BUCKET ROLL-BACK FORCE AT MAX. HEIGHT	N (lbf.)	9403 (2114)	9685 (2177)
XX	BUCKET ROLL-BACK FORCE AT 1500 mm	N (lbf.)	11646 (2618)	11998 (2697)
ZZ	BUCKET ROLL-BACK FORCE AT GROUND LEVEL	N (lbf.)	9545 (2146)	9855 (2215)
	RAISING TIME (RATED FLOW)	sec.	4.1	3.5
	LOWERING TIME (RATED FLOW)	sec.	2.4	2.3
	BUCKET DUMPING TIME (RATED FLOW)	sec.	2.0	1.7
	BUCKET ROLLBACK TIME (RATED FLOW)	sec.	2.6	2.2

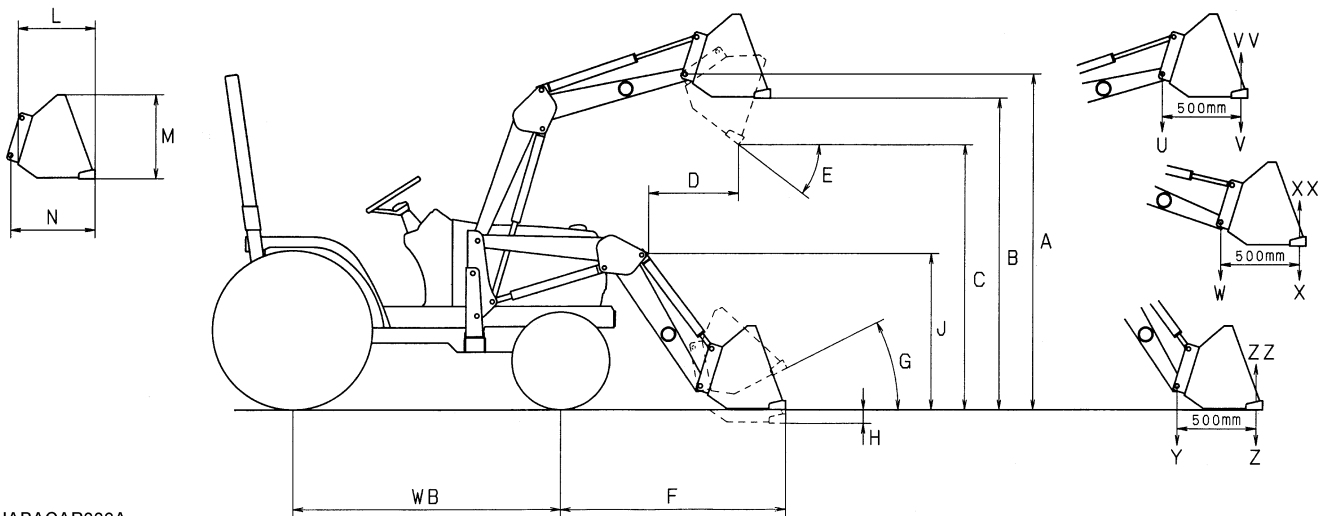

1A1ABACAP003A



**LA525 (L2501)**

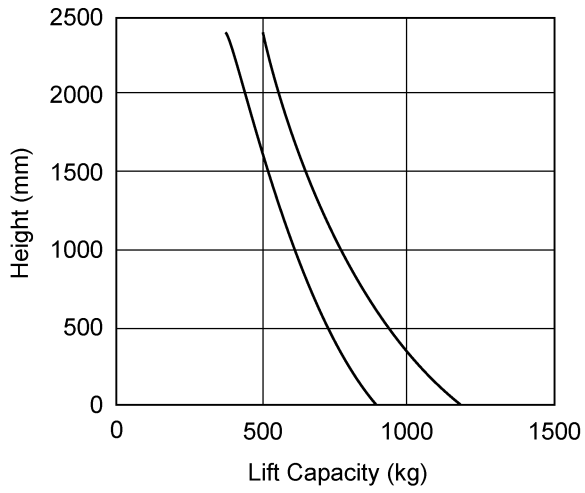

1AIABEFAP032A

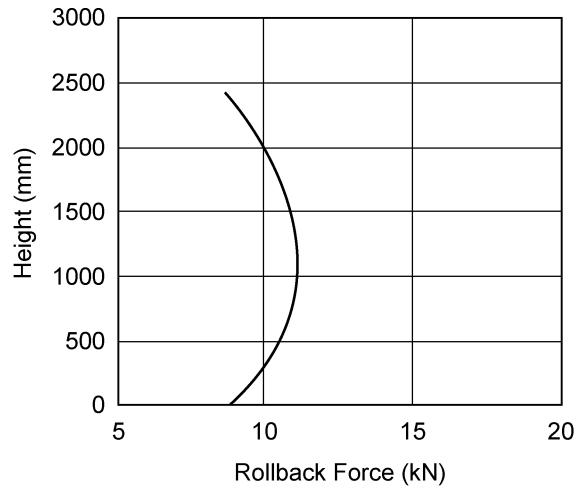

**LA525 (L3301, L3901)**

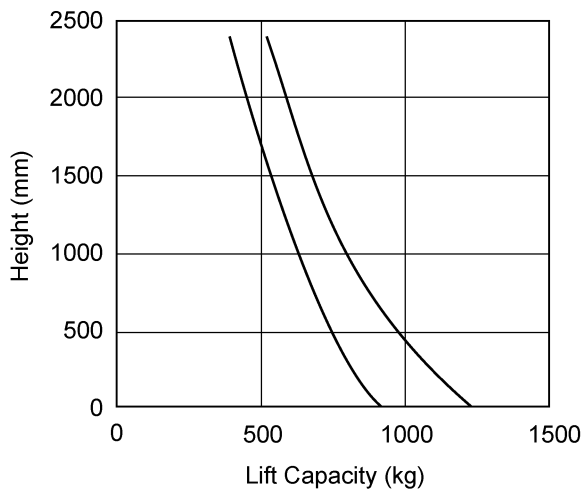

1AIABEFAP033A

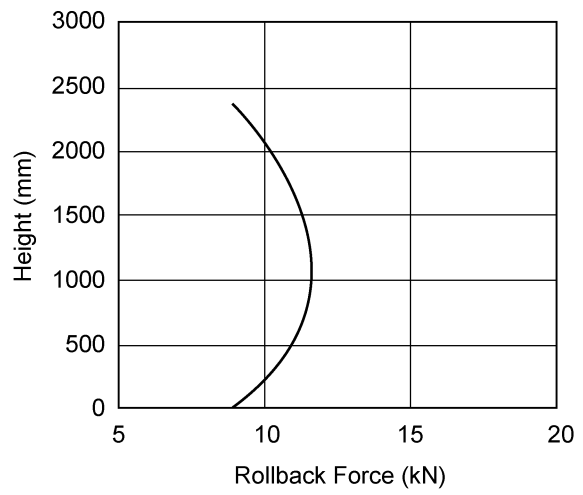

## LOADER TERMINOLOGY

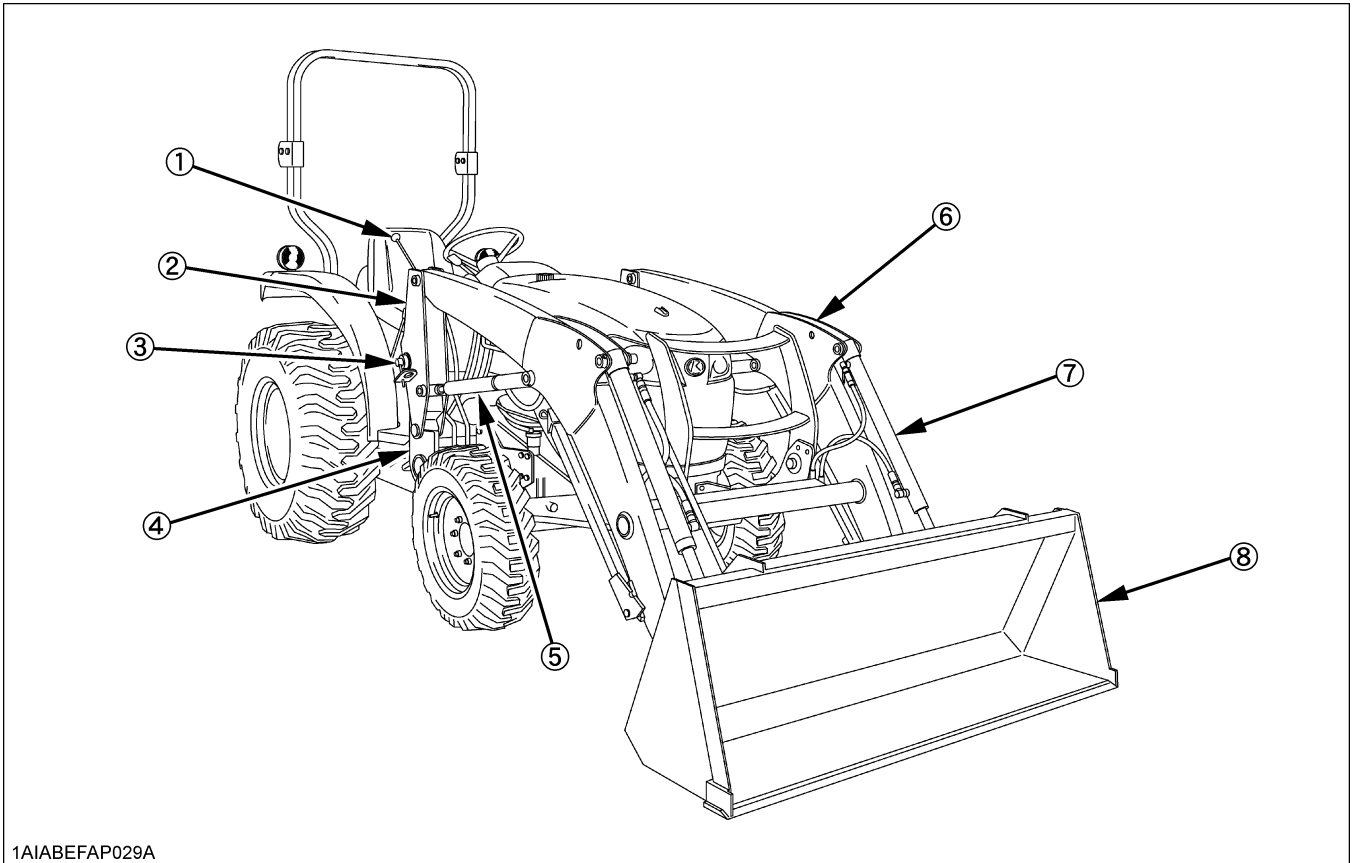

1A1ABEFAP029A

- (1) Loader control lever
- (2) Side frame
- (3) Mounting pin
- (4) Main frame
- (5) Boom cylinder

- (6) Boom
- (7) Bucket cylinder
- (8) Bucket

# PRE-OPERATION CHECK

## LUBRICATION

Lubricate all grease fittings with SAE multipurpose grease.

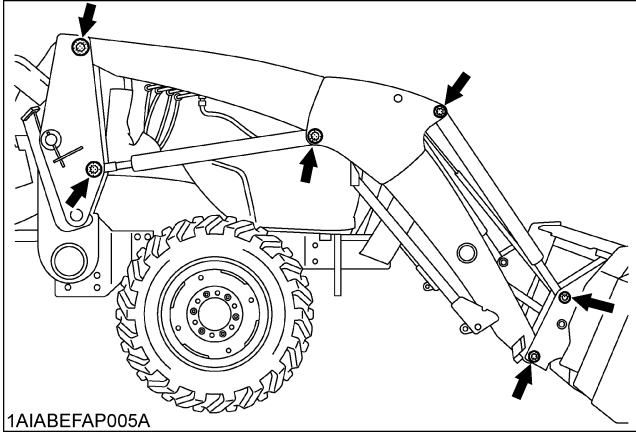

## [HST Type]

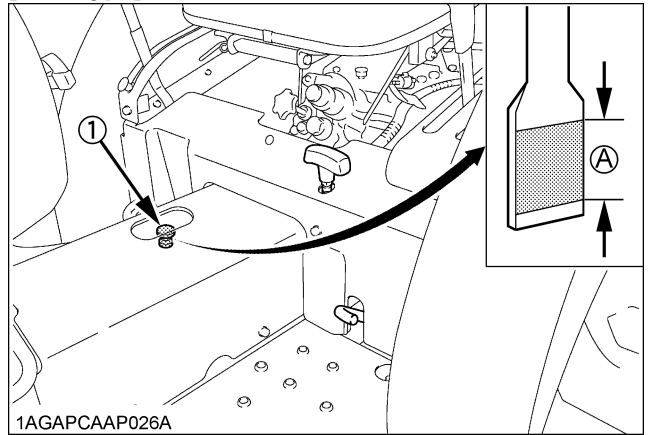

(1) Dipstick (A) Oil level is acceptable within this range

## TRANSMISSION FLUID

Check the tractor transmission fluid level. Add fluid if necessary. Refer to the tractor operator's manual for instructions and proper fluid. Repeat this check after purging air from the system. At that time, it will be necessary to add transmission fluid.

### [Manual Transmission Type]

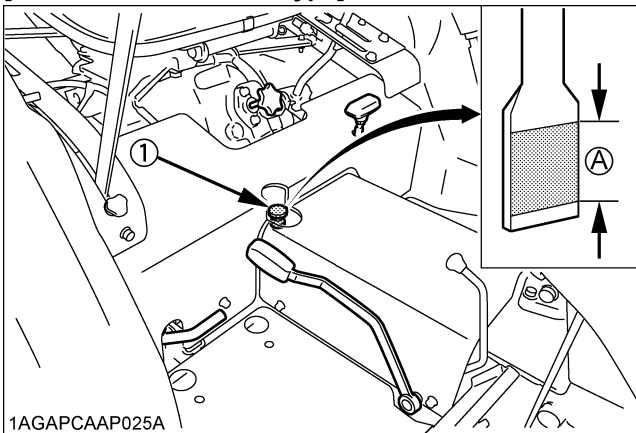

(1) Dipstick (A) Oil level is acceptable within this range

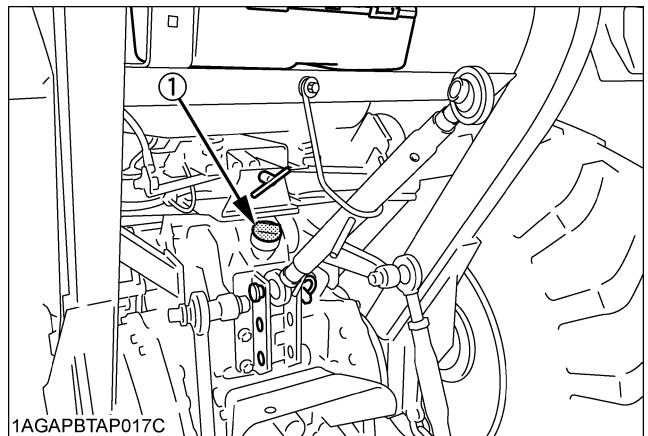

(1) Oil inlet

### IMPORTANT :

- To check the tractor transmission fluid level, lower the bucket to the ground and lower the 3 point hitch.

## TREAD

1. Set front tread as follows.

	Front Tread	
	2WD	4WD
L2501 L3301 L3901	Front axle is not adjustable.	Front axle is not adjustable.

**IMPORTANT :**

- Setting tread wider than recommended may cause premature failure of front axle components due to excessive stress.

2. For better stability, set the rear tread as follows depending on the requirements of the work being done.

	Rear Tread
L2501 L3301 L3901	1115 mm (43.9 in.) or more

## REAR BALLAST



### WARNING

To avoid serious injury:

- For tractor stability and operator's safety, rear ballast should be added to the rear of the tractor in the form of 3-point counter weight and rear wheel ballast. The amount of rear ballast will depend on the application.

Implement as Counter Weight	
6' Box Scraper	Approx. 450 kg (990 lbs.)
Rotary Tiller	Approx. 240 kg (530 lbs.)
Back Hoe	Approx. 770 kg (1690 lbs.)

## ■ Liquid ballast in rear tires

Water and calcium chloride solution provides a safe and economical ballast. Used properly, it will not damage tires, tubes or rims. The addition of calcium chloride is recommended to prevent the water from freezing. Use of this method of weighting the wheels has full approval of the tire manufacturers. See your tire dealer for this service.

Liquid weight per tire (75 Percent filled)

Tire sizes	11.2-24	15-19.5
Slush free at -10 °C (-14 °F) Solid at -30 °C (-22 °F) [Approx. 1 kg (2 lbs.) CaCl <sub>2</sub> per 4 L (1 gal.) of water]	105 kg (230 lbs.)	140 kg (309 lbs.)
Slush free at -24 °C (-11 °F) Solid at -47 °C (-52 °F) [Approx. 1.5 kg (3.5 lbs.) CaCl <sub>2</sub> per 4 L (1 gal.) of water]	110 kg (240 lbs.)	150 kg (331 lbs.)
Slush free at -47 °C (-52 °F) Solid at -52 °C (-62 °F) [Approx. 2.25 kg (5 lbs.) CaCl <sub>2</sub> per 4 L (1 gal.) of water]	115 kg (253 lbs.)	160 kg (353 lbs.)

**IMPORTANT :**

- Do not fill tires with water or solution more than 75% of full capacity (to the valve stem level at 12 o'clock position).

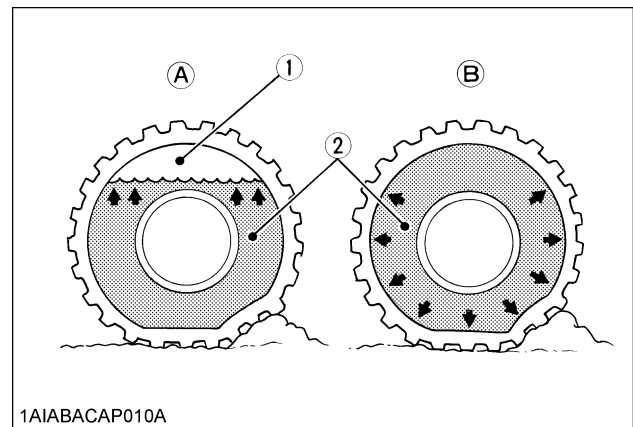

1A1ABACAP010A

- (1) Air
- (2) Water
- (A) Correct: 75% Full  
Air compresses like a cushion
- (B) Incorrect: 100% Full  
Water can not be compressed

**NOTE :**

- When mounting a heavy rear implement, liquid in the tires may not be required.

**IMPORTANT :**

- Do not add liquid ballast or any other weights to the front tires.

## TIRE INFLATION

Ensure that the tractor tires are properly inflated.  
Refer to the tractor operator's manual for optional tires.

### ■ Inflation pressure

	Tire sizes	Inflation Pressure
Rear	11.2-24, 4PR	100 kPa (1.0 kgf/cm <sup>2</sup> , 14 psi)
	13.6-16, 4PR	100 kPa (1.0 kgf/cm <sup>2</sup> , 14 psi)
	15-19.5, 6PR	210 kPa (2.1 kgf/cm <sup>2</sup> , 30 psi)
Front	5.00-15, 4PR	220 kPa (2.2 kgf/cm <sup>2</sup> , 32 psi)
	7-16, 6PR	180 kPa (1.8 kgf/cm <sup>2</sup> , 26 psi)
	23 x 8.50-12, 4PR	160 kPa (1.6 kgf/cm <sup>2</sup> , 23 psi)
	25 x 8.50-14, 6PR	160 kPa (1.6 kgf/cm <sup>2</sup> , 23 psi)
	27 x 8.50-15, 6PR	210 kPa (2.1 kgf/cm <sup>2</sup> , 30 psi)

## TEST OPERATION



### WARNING

To avoid serious personal injury:

- Keep engine speed at low idle during the test operation.
- Escaping hydraulic fluid under pressure can have sufficient force to penetrate skin, causing serious personal injury.

Before disconnecting lines, be sure to relieve all pressure by moving the controls.

Before applying pressure to the system, be sure all connections are tight and that lines, tubes and hoses are not damaged.

Fluid escaping from a very small hole can be almost invisible. Use a piece of cardboard or wood, rather than your hands to search for suspected leaks.

If injured by escaping fluid, see a doctor at once. Serious infection or allergic reaction will develop if proper medical treatment is not administered immediately.

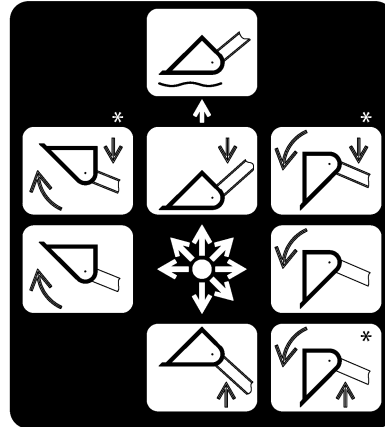

1A1ABACAP011B

### NOTE :

- When the lever is at each corner position marked by asterisk (\*) or lower left, boom and bucket cylinders work at the same time. However, the lower left position (Raise & Roll back) is not recommended for scooping because of insufficient lift force.

To begin a test operation, slightly move the control lever from the "N" position. Slowly raise the loader boom just enough for the bucket to clear the ground when fully dumped. Slowly work through the dump and roll back cycles.

### IMPORTANT :

- If the boom or bucket does not work in the directions indicated on the label, lower the bucket to the ground, stop the engine, and relieve all hydraulic pressure. Recheck and correct all hydraulic connections and oil level.

## REMOVING AIR FROM THE HYDRAULIC SYSTEM

Repeat raising and lowering the boom and bucket operations until all the air is removed from the system and the system responds properly.

### IMPORTANT :

- Do not move the control lever into the float position when the bucket is off the ground.

# OPERATING THE LOADER

The loader should be operated with the tractor engine speed depending on the application and the operator's level of experience. Excessive speeds are dangerous, and may cause bucket spillage and unnecessary strain on the tractor and loader.

When operating in temperatures below  $-1\text{ }^{\circ}\text{C}$  ( $30\text{ }^{\circ}\text{F}$ ), run the tractor engine below 1200 rpm until the oil temperature exceeds  $-1\text{ }^{\circ}\text{C}$  ( $30\text{ }^{\circ}\text{F}$ ).

The following text and illustrations offer suggested loader and tractor operating techniques.



## WARNING

To reduce the possibility of roll over:

- It is not recommended that the loader be attached when operating another implement on a hillside.

## IMPORTANT :

- Before operating the loader in rough terrain, remove the mower to avoid damage to the mower.

## FILLING THE BUCKET

Approach and enter the pile with a level bucket.

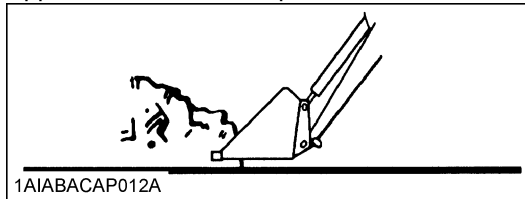

Ease control lever toward you and then left to rollback and lift the bucket.

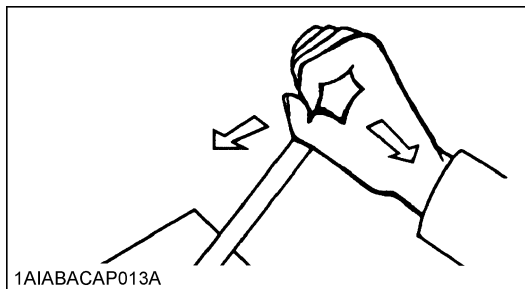

The rollback and lifting of the bucket will increase efficiency because a level bucket throughout the lifting cycle resists bucket lift and increases breakaway effort.

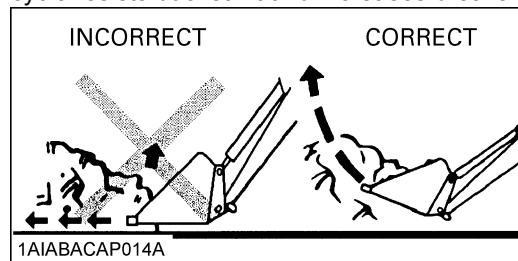

## NOTE :

- Do not be concerned if the bucket is not completely filled during each pass. Maximum productivity is determined by the amount of material loaded in a given period of time. Time is lost if two or more attempts are made to fill the bucket on each pass.

## LIFTING THE LOAD

When lifting the load, keep the bucket positioned to avoid spillage.

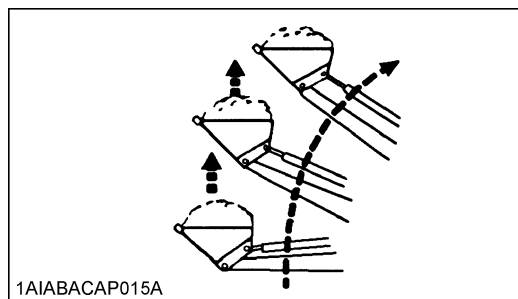

## WARNING

To avoid serious personal injury:

- Do not attempt to lift bucket loads in excess of the loader capacity.
- Before raising the bucket to full height, make sure the tractor is on level ground. If not, it may tip over, even if the tractor is not moving.

## CARRYING THE LOAD

Position the bucket just below the level of the tractor hood for maximum stability and visibility, whether the bucket is loaded or empty.

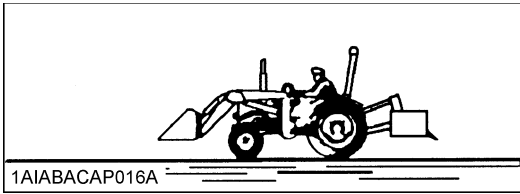

Use extreme care when operating the loader on a slope. Keep the bucket as low as possible. This keeps the bucket and tractor center of gravity low and will provide maximum tractor stability.



### WARNING

To avoid serious personal injury:

- Be extra careful when working on inclines.
- When operating on a slope, always operate up and down the slope, never across the slope.

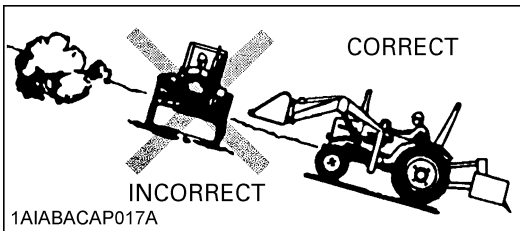

When transporting a load, keep the bucket as low as possible to avoid tipping, in case a wheel drops in a rut.

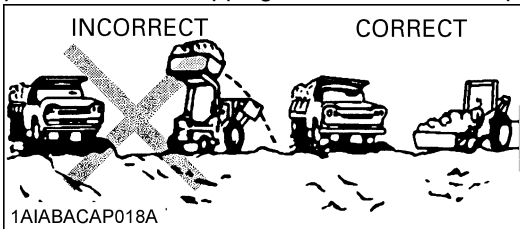

## DUMPING THE BUCKET

Lift the bucket just high enough to clear the side of the vehicle. Move the tractor in as close to the side of the vehicle as possible, then dump the bucket.

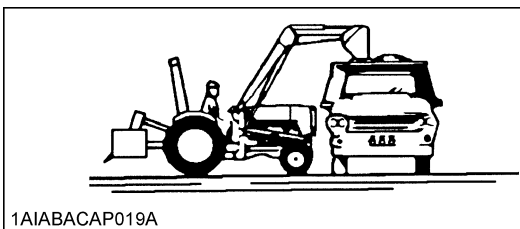

## LOWERING THE BUCKET

After the bucket is dumped, back away from the vehicle while lowering and rolling back the bucket.

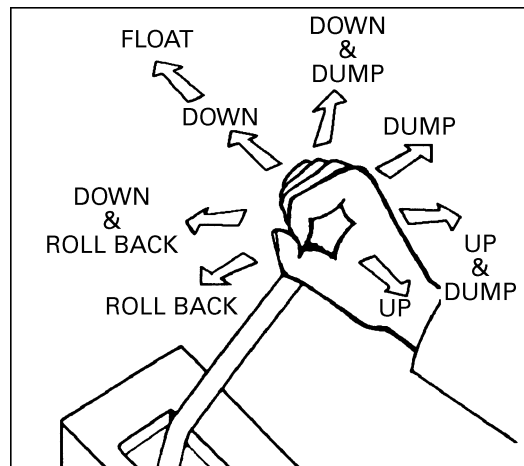

## OPERATING WITH FLOAT CONTROL

During operation on hard surfaces, keep the bucket level and put the lift control in the float position to permit the bucket to float on the working surfaces.

If hydraulic down pressure is exerted on the bucket it will wear faster than normal.

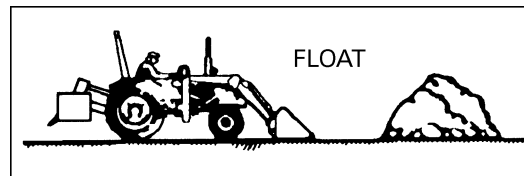

The float position will also avoid mixing of surface material with stockpile material. The float position will reduce the chance of surface gouging while removing snow or other material, or when working with a blade.

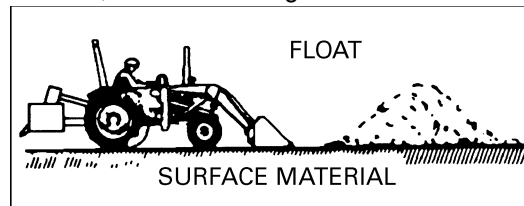

## LOADING FROM A BANK

Choose a forward gear that provides a safe ground speed and power for loading.

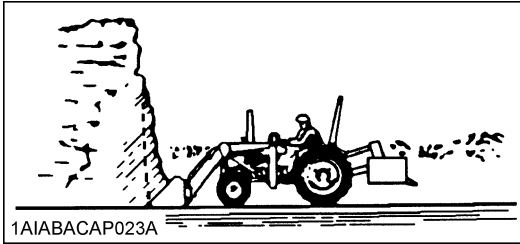

### WARNING

To avoid serious personal injury:

- Be extra careful when working on inclines.
- When operating on a slope, always operate up and down the slope, never across the slope.

### NOTE :

- Loader lift and break-away capacity diminish as loading height is increased.

Side cutting is a good technique for cutting down a big pile. Wheel width should not exceed the bucket width for this procedure.

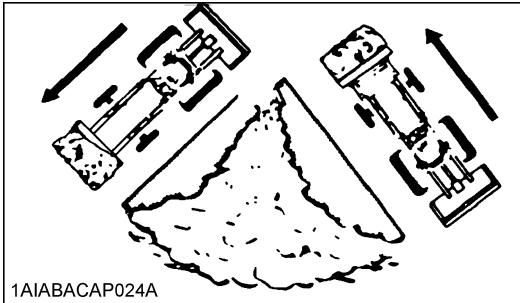

If the pile sides are too high and liable to cause cave-in, use the loader to break down the sides until a slot can be cut over the top.

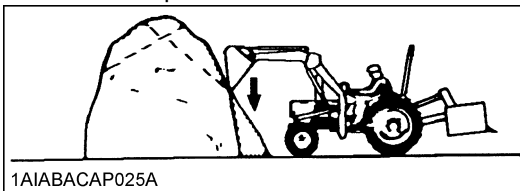

Another method for large dirt piles is to build a ramp to approach the pile.

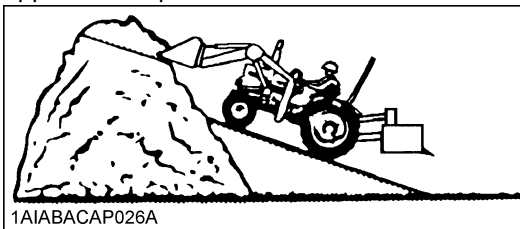

It is important to keep the bucket level when approaching a bank or pile. This will help avoid gouging the work area.

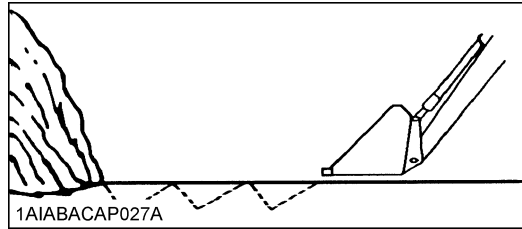

## PEELING AND SCRAPING

Use a slight bucket down angle, travel forward, and hold the lift control forward to start the cut. Make a short cut and break-out cleanly.

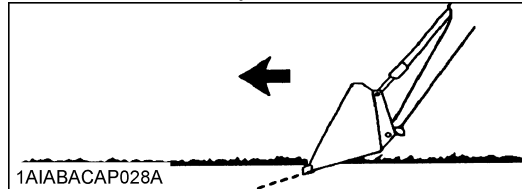

With the bucket level, start a cut at the notch approximately 2 in. deep. Hold the depth by feathering the bucket control to adjust the cutting edge up or down. When the front tires enter the notch, adjust the boom cylinder to maintain proper depth.

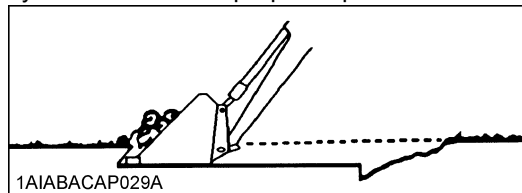

Make additional passes until the desired depth is reached. During each pass, use only the bucket control while at working depth. This will allow you to concentrate on controlling the bucket angle to maintain a precise cut.

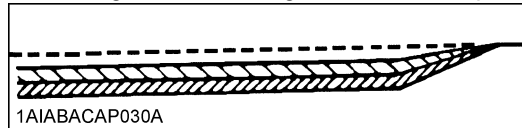



## LOADING LOW TRUCKS OR SPREADERS FROM A PILE

For faster loading, minimize the angle of turn and length of run between pile and spreader.

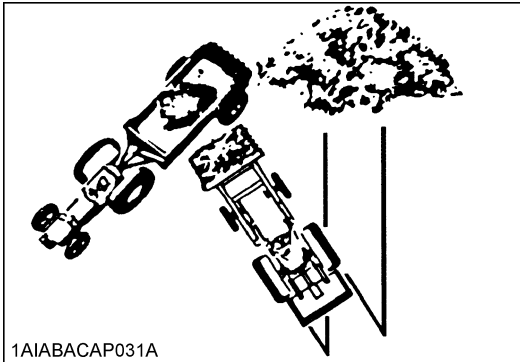

Backgrade occasionally with a loaded bucket to keep the work surface free of ruts and holes. Also, hold the lift control forward so the full weight of the bucket is scraping the ground. Use the heel of the bucket

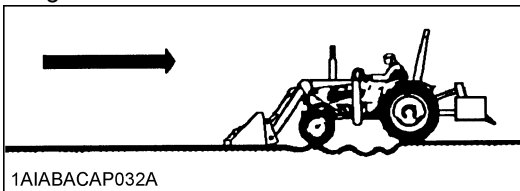

## BACKFILLING

Approach the pile with the bucket flat.

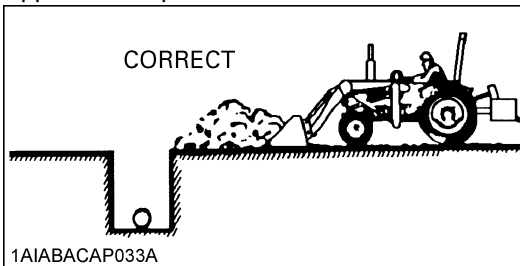

Poor operating methods will move less dirt and make it more difficult to hold a level grade.

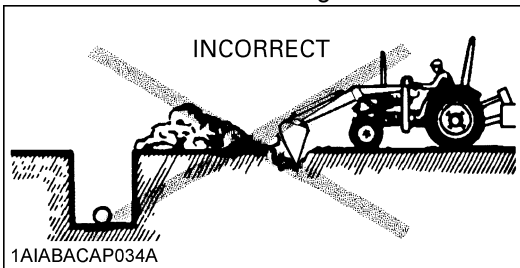

### IMPORTANT :

- Do not use the bucket in the dumped position for bulldozing. As shown above, this method will impose severe shock loads on the dump-linkage, the bucket cylinders, and the tractor.

Leave dirt in the bucket because dumping on each pass wastes time.

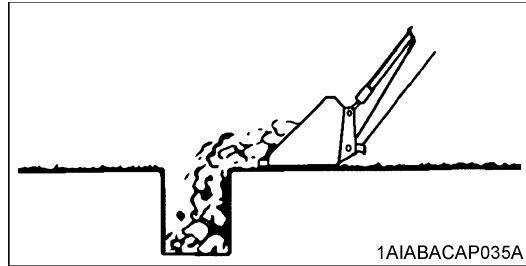

Operate at right angles to the ditch. Taking as big a bite as the tractor can handle.

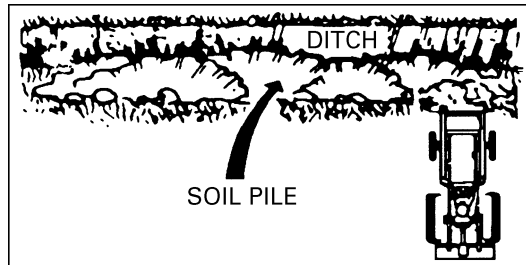

Leave dirt which drifts over the side of the bucket for final cleanup.

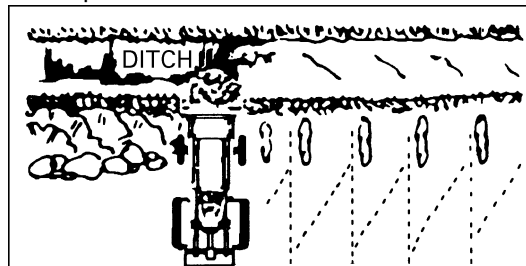

Pile dirt on the high side for easier backfilling on a slope.

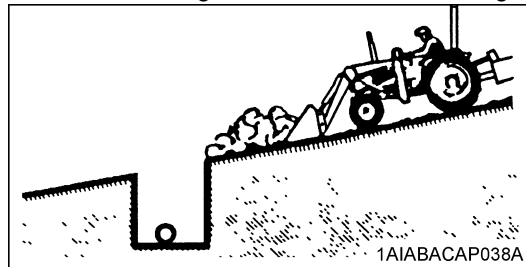

## HANDLING LARGE HEAVY OBJECTS



### DANGER

To avoid serious personal injury or death:

- Handling large, heavy objects can be dangerous due to :
  - (A) Danger of rolling the tractor over.
  - (B) Danger of upending the tractor.
  - (C) Danger of the object rolling or sliding down the loader boom onto the operator.
- If you must perform the above work, protect yourself by :
  - (A) Not lifting the load higher than necessary to clear the ground when moving.
  - (B) Adding rear ballast to the tractor to compensate for the load.
  - (C) Not lifting large objects with equipment that does not have an anti-rollback device.
  - (D) Moving slowly and carefully.
  - (E) Avoiding rough terrain.
  - (F) Keeping transport distance as short as possible and carry the load as low as possible during transport.

## VALVE LOCK



### WARNING

To avoid injury from crushing:

- Do not utilize the valve lock for machine maintenance or repair.
- The valve lock is to prevent accidental actuation when implement is not in use or during transport.

The control valve is equipped with a valve lock feature. The control valve is locked in the neutral position.

The lock is not intended and will not prevent a leak down of the implement during the period of storage.

### Standard valve

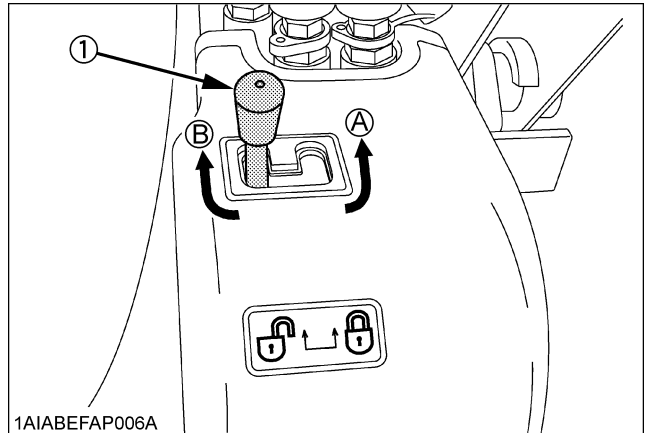

(1) Lock lever

(A)  "Lock"

(B)  "Unlock"

## FRONT GUARD



### CAUTION

To avoid personal injury or machine damage:

- Do not open nor close the hood while the upper front guard is closed.
- Be sure to keep the front guard closed (back at its locked position) when operating the tractor or the loader.

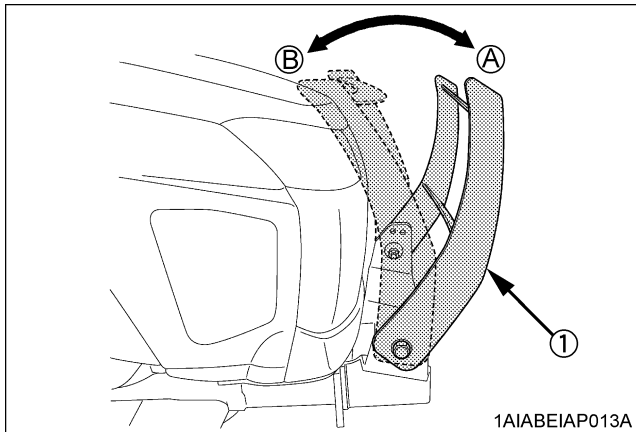

(1) Front guard

(A) "Open"

(B) "Closed (Locked)"

### ◆ How to open the front guard

1. Lower the boom to the ground with the bucket in level position.
2. Pull the front guard lever and open the front guard.

### IMPORTANT :

- Lower the front loader to the ground before opening the front guard.
- Do not raise the boom while the upper front guard is opened.

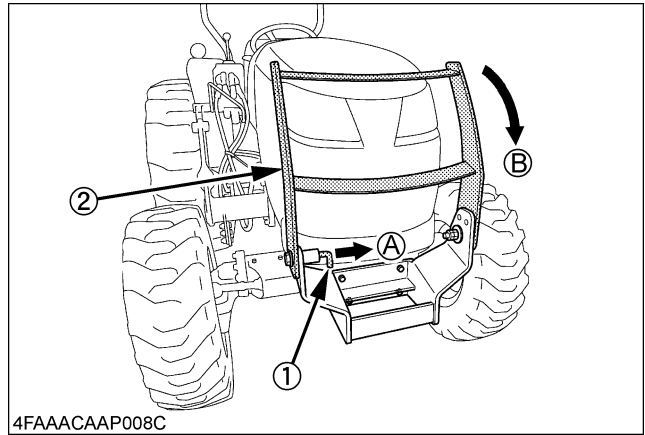

(1) Front guard lever

(A) "Unlock"

(2) Front guard

(B) "Open"

### IMPORTANT :

- Before moving the tractor or the front loader, make sure the front guards are tightly locked.

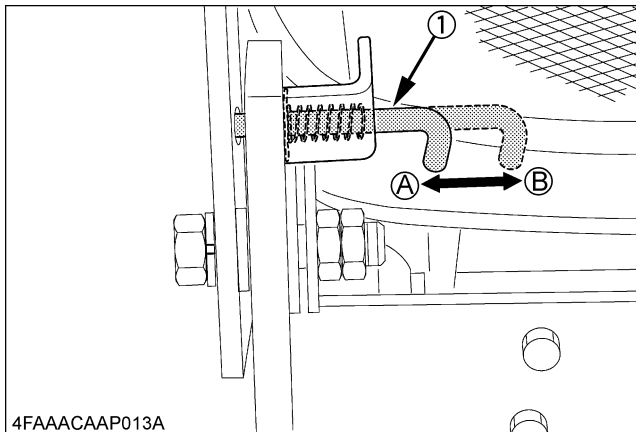

4FAAACAAP013A

(1) Front guard lever

(A) "Lock position"

(B) "Unlock position"

## BUCKET LEVEL INDICATOR (if equipped)

Depending on the front attachment, loosen the indicator rod lock bolt and readjust the indicator rod length.

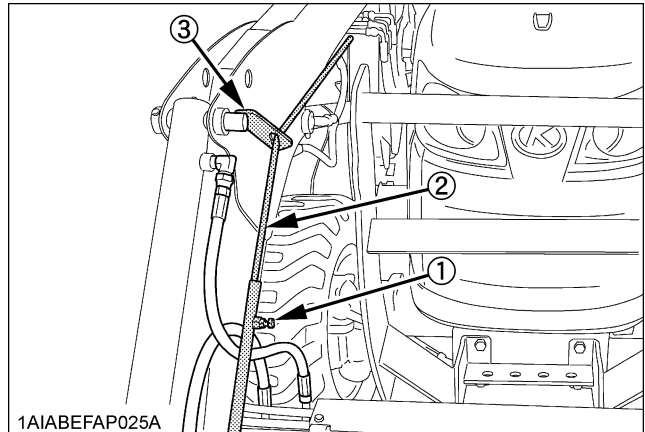

1AIABEFAP025A

(1) Bolt

(2) Indicator rod

(3) Guide, Indicator rod

## ATTACHING ATTACHMENTS (if equipped)

This quick attach coupler is designed to be used with Kubota attachments. Non-Kubota attachments, if used, must comply with ISO 24410, first edition 2005-04-15. This quick attach coupler allows the operator to change easily without the use of tools.



### DANGER

To avoid serious personal injury or death:

- Use of a non-Kubota attachment that does not comply with ISO 24410 or the improper positioning of handle(s) or non-protrusion of pin(s) may result in detachment of the attachment or deformation, causing loss of performance, personal injury or death.

### NOTE :

- Attachments should be located on a flat, firm surface when attaching and detaching them from the quick attach coupler.
1. To mount an attachment, pull the handles of the quick attach coupler latching pins to the unlatched position. The quick attach coupler handles must be all the way up to ensure that the latching pins are fully retracted.
  2. Position the tractor squarely in front of the attachment and tilt the quick attach coupler forward with the bucket cylinders.

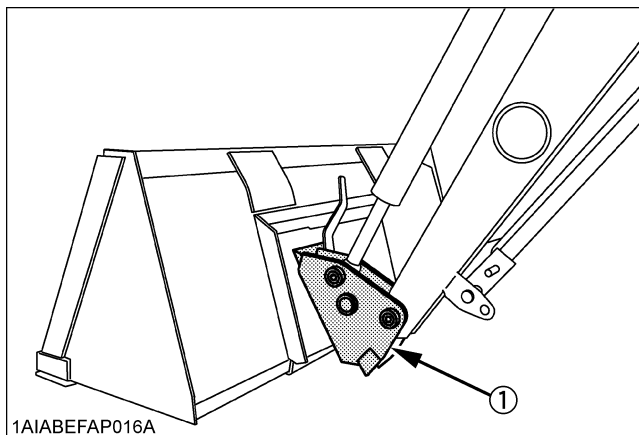

1AIABEFAP016A

(1) Quick attach coupler

3. Ease the quick attach coupler mounting plate into the saddle of the attachment.
4. Roll the quick attach coupler back using the bucket cylinders and raise the boom slightly. The back of the attachment should rest against the front of the quick attach coupler mounting plate and the weight of the attachment should be supported by the loader.

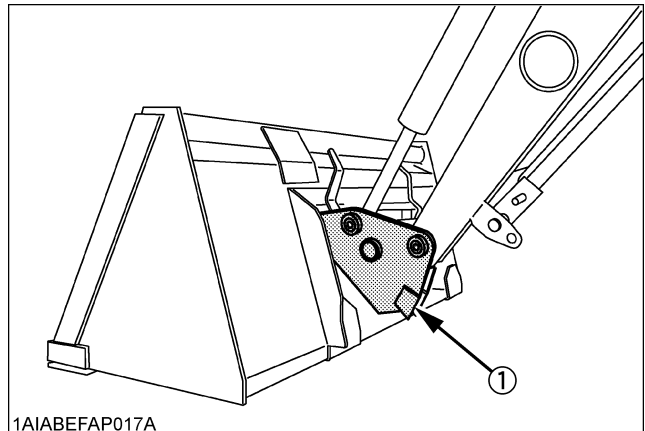

1AIABEFAP017A

(1) Quick attach coupler



### WARNING

To avoid serious injury or machine damage:

- Raise the boom only enough to latch the attachment.  
The attachment could swing off the quick attach coupler.
5. When the attachment is properly seated in the saddle and against the front of the quick attach coupler mounting plate, turn off the engine and set the parking brake. Push the quick attach coupler handles to the fully latched position. Verify both latching pins are completely engaged in the base of the attachment.

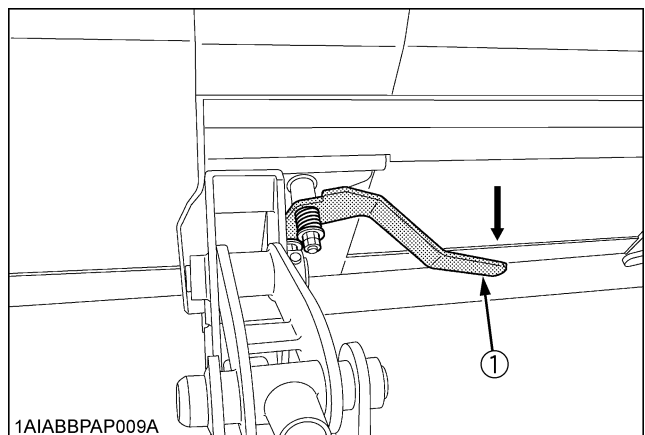

1AIABBPAP009A

(1) Quick attach coupler handle



## DANGER

To avoid serious personal injury or death:

- The following engagement points are critical.

- 1) The lock pins of the quick attach coupler have to protrude into and through the pin slots of the attachment on both sides. It is critical that the pins are in good condition and without visible signs of wear or damage and that the operator align the loader quick attach coupler with the attachment to allow the pins to go through the pin slots.
- 2) Both handles have to be pushed down until the handles contact the ear plates near the points where the pin bolt goes through the handle (A).
- 3) Do not operate the tractor or attachment unless all of the above conditions are met.

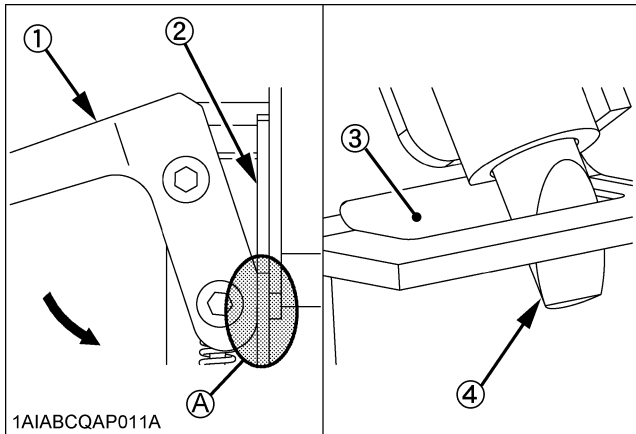

1AIABCQAP011A

- (1) Handle
- (2) Ear plate
- (3) Pin slot
- (4) Lock pin

(A) The handle contacts the ear plate at the points.

6. Visually verify when pushing the quick attach coupler handles into locked position that the latch pins rotate completely and are located underneath the stop of the quick attach coupler.

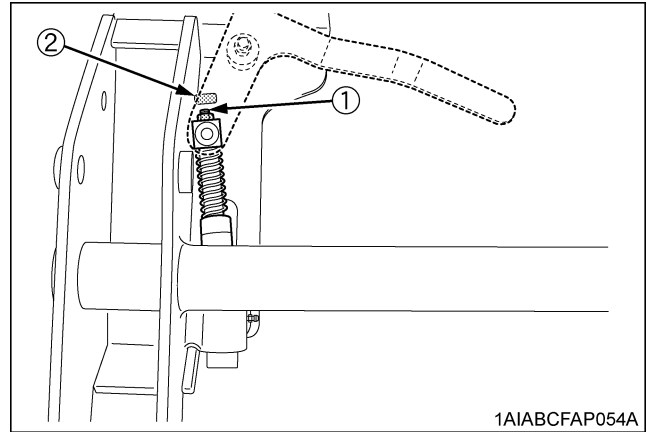

1AIABCQAP054A

- (1) Latch pins
- (2) Quick attach coupler stopper

7. When attaching different attachments visually inspect for broken or damaged pins. If broken or damaged pins are found, replace before using. Use of broken pins may result in attachment detachment or deformation, causing loss of performance, personal injury or death.
8. You are now ready to use the attached attachment. All compatible attachments attach and detach using the same method.



## WARNING

To avoid serious injury or machine damage:

- Never operate or transport attachments which are not attached completely.
- Always replace damaged hardware immediately.

## DETACHING ATTACHMENTS

1. Detaching attachments is done in the reverse of attaching attachments. The procedure is below.
2. Lower the attachment to ground level with the attachment slightly in the rolled back position. Stop the engine and set the parking brake.
3. Pull the quick attach coupler handles to the unlatched position to release the latching pins.
4. While sitting in the tractor operator's seat, start the engine and slowly move the loader control lever to the "DUMP" position until the attachment is pushed away slightly from the quick attach coupler.
5. Lower the loader boom so that the quick attach coupler mounting plate clears the attachment saddle.
6. Back away from the attachment slowly.
7. If an attachment is not going to be attached to the quick attach coupler immediately, push the handles of the quick attach coupler to the locked position to prevent damage to the handle assembly.

## DISMOUNTING THE LOADER



### WARNING

To avoid machine damage or serious injury:

- Remove loader from tractor only when an approved loader bucket is attached.

Follow instructions provided in "REMOVING THE LOADER" section in this operator's manual.

## MAINTENANCE

1. Attachments are secured to the quick attach coupler with an over center latching system. It is important that these parts are kept clean, lubricated and free from debris.
2. Keep the latching pins and latching handles free from debris. Lubricate the latching pins weekly with grease.

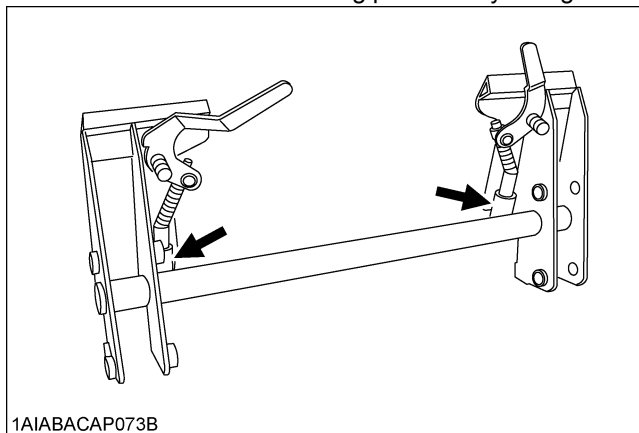

1AIABACAP073B

3. Keep the latching handles tight. If the handles become loose, tighten the hex nut slightly to remove any play from the handles.
4. Clean the saddle, at the top of the attachment, and the latching pin slots of any dirt and debris before mounting an attachment to the quick attach coupler.

## ATTACHMENTS

### ■ Quick attach bucket

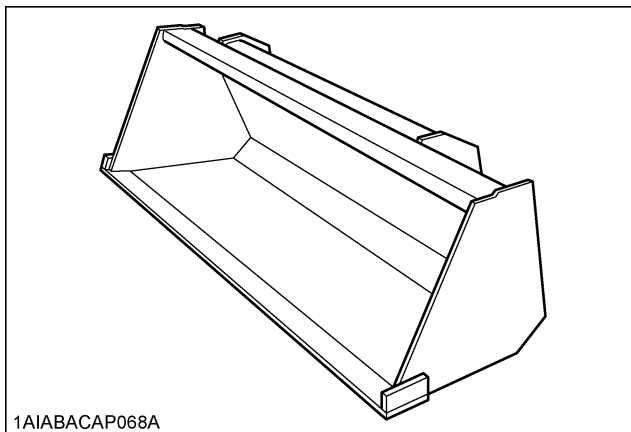

1AIABACAP068A

-SQUARE 66"  
WIDTH  
1675mm (66in.)  
STUCK CAPACITY  
0.23cu.m. (8.1cu.ft.)

### ■ Bale spear

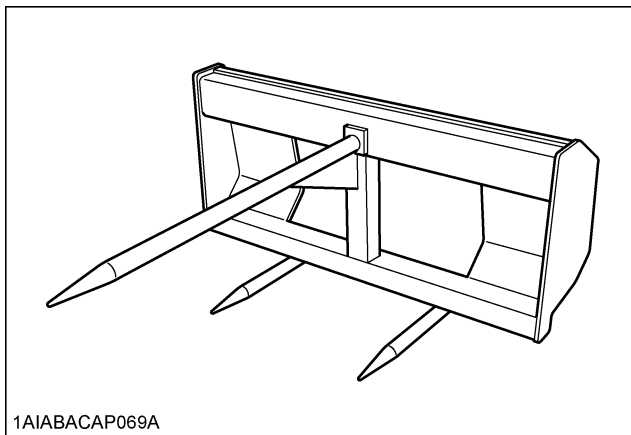

1AIABACAP069A

OVERALL HEIGHT  
524mm (20.63in.)  
OVERALL WIDTH  
1149mm (45.24in.)  
OVERALL LENGTH (INCLUDING MAIN SPEAR)  
1376mm (54.17in.)  
USEABLE LENGTH OF MAIN SPEAR  
1008mm (39.69in.)  
USEABLE LENGTH OF SPEAR 2  
356mm (14.02in.)  
MAXIMUM DIAMETER OF MAIN SPEAR  
51mm (2.00in.)  
DIAMETER OF SPEAR 2  
32mm (1 1/4in.)  
WEIGHT OF IMPLEMENT  
74kg (163lbs)

■ Pallet fork

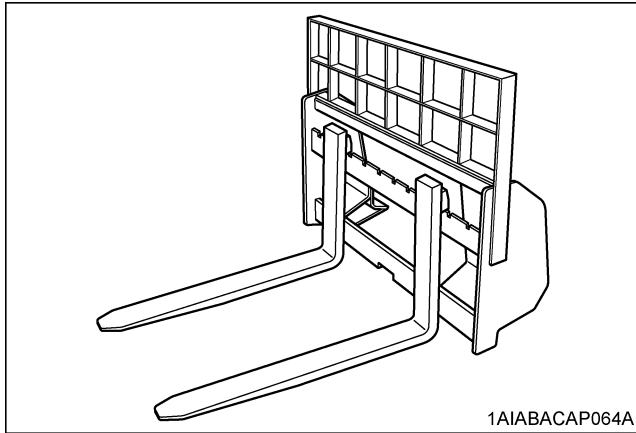

LOADER MODEL  
LA525

RATED CAPACITY  
322 kg (710 lbs.)

**ASSEMBLE PALLET FORK**

1. Install the fork to the middle of the frame.  
(fit the lower hook of the fork to the center notch of the frame)

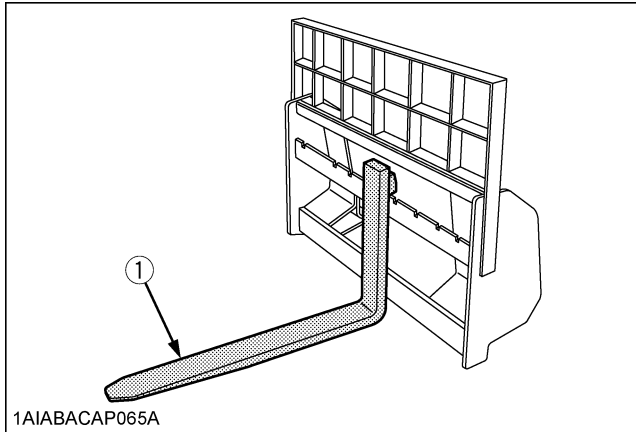

(1) Fork (36")

2. Slide the fork to the desired position.

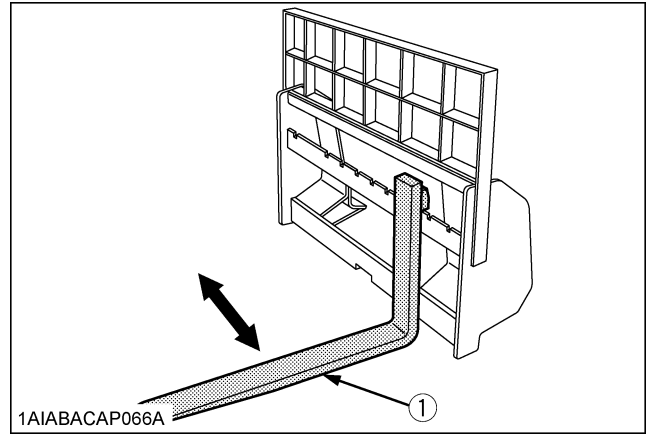

(1) Fork (36")

3. Push the lock lever and slide the fork slightly until the lock pin engages with one of the notches to lock the fork.

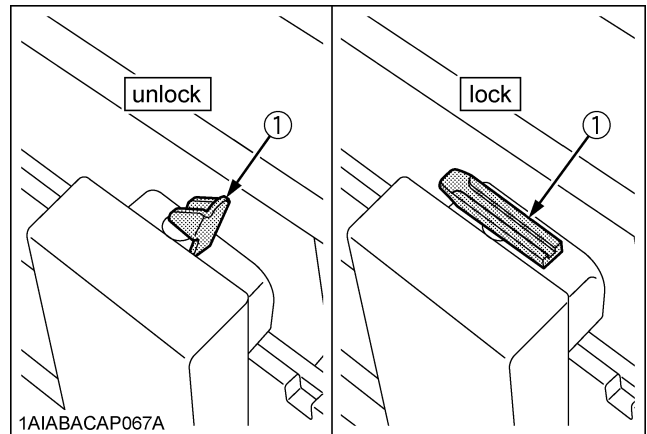

(1) Lock lever

4. The other fork can be installed using the same procedures.

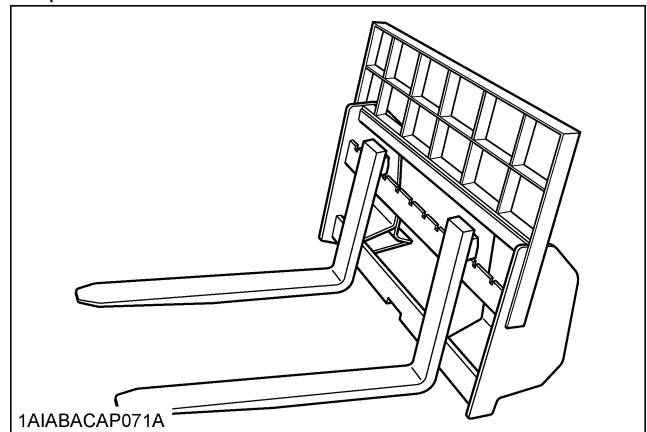

# MAINTENANCE



## WARNING

To avoid serious injury:

- Be sure to check and service the tractor on a flat surface with the bucket on the ground, engine shut off, the key removed and the parking brake on.

## LUBRICATION

1. Lubricate all grease fittings every 10 hours of operation. Also, lubricate joints of control lever linkage every 10 hours. High quality grease designating "extreme pressure" and containing Molybdenum disulfide is recommended. This grease may specify "Moly EP" on its label.

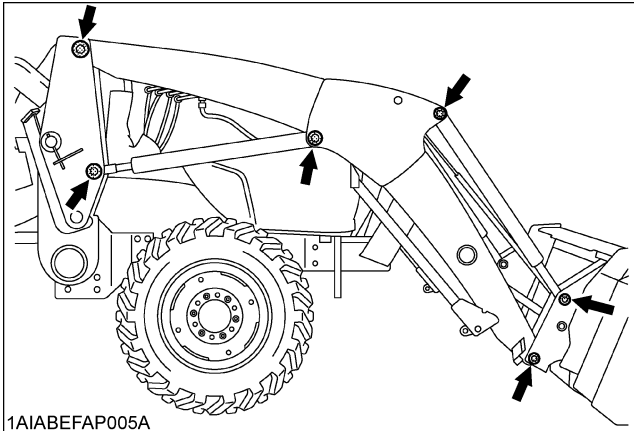

2. Daily before operation, check the tractor hydraulic fluid level. If low, add as described in the tractor's operator's manual. Also change the filter element and the hydraulic fluid as recommended in the tractor's operator's manual.

## RE-TIGHTENING OF HARDWARE

After 20 to 30 hours of initial loader operation, re-tighten all mounting bolts and nuts to the required torque value as follows.

Sequence	Location	Bolt/Nut	Required Torque N-m (kgf-m, ft-lbs)
1	Main frames	M16 bolts	226 (23, 166)



## DAILY CHECKS

1. Check all hardware daily before operation.  
Tighten hardware to torque values as specified in the "Installation Instructions" and "Tightening Torque Chart".
2. With the engine off and the bucket on the ground, inspect all hoses for cuts or wear. Check for signs of leaks and make sure all fittings are tight.



### WARNING

To avoid serious personal injury:

- Escaping hydraulic fluid under pressure can have sufficient force to penetrate skin, causing serious personal injury. Before disconnecting lines, be sure to relieve all pressure. Before applying pressure to the system, be sure all connections are tight and that lines, tubes, and hoses are not damaged. Fluid escaping from a very small hole can be almost invisible. Use a piece of cardboard or wood, rather than your hands, to search for suspected leaks.

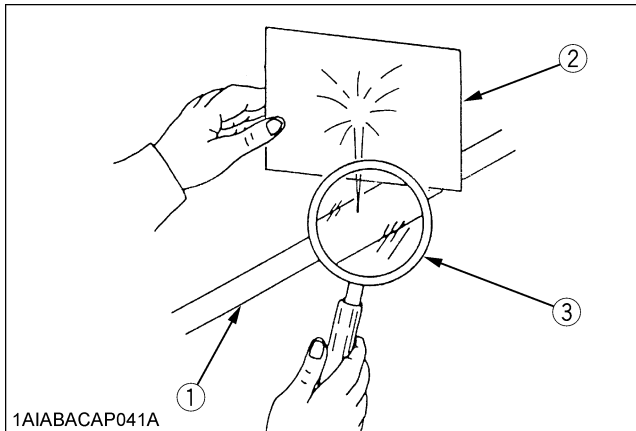

1AIABACAP041A

- (1) Hydraulic line
- (2) Cardboard
- (3) Magnifying glass

If injured by escaping fluid, see a doctor at once. Serious infection or allergic reaction will develop if proper medical treatment is not administered immediately.

- When removing the engine side covers, be careful not to touch hot loader cylinders. Allow all surfaces to cool before performing maintenance.
- Before servicing the loader or the tractor, be sure to place the loader boom in contact with the ground. If the loader boom must be raised during service or maintenance, support the boom as shown in the figure.

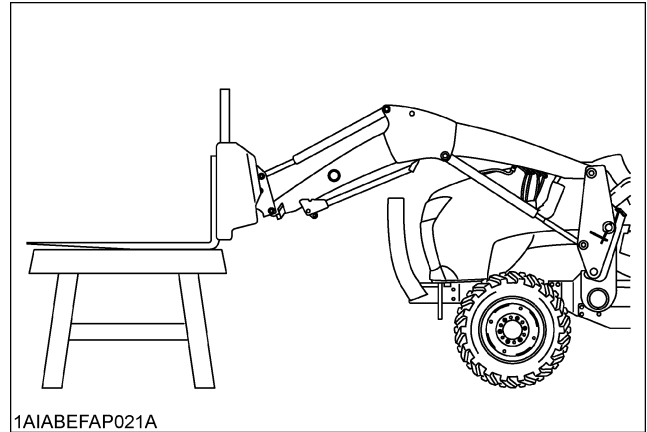

1AIABEFAP021A

## EVERY 50 HOURS

### ■ Checking main frame bolt torque



### CAUTION

To avoid personal injury:

- Never operate front loader with a loose main frame.
- Any time bolts and nuts are loosened, retighten to specified torque.
- Check all bolts and nuts frequently and keep them tight.

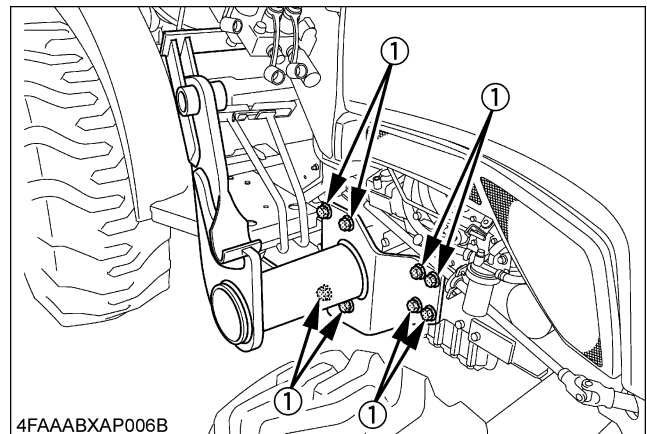

Check main frame bolts regularly especially when new. If they are loose, tighten them as follows.



4FAAABXAP006B

- (1) Tightening torque : 226 N-m (23 kgf-m, 166 ft-lbs)

**General torque specification**

American standard screws, bolts and nuts with UNC or UNF threads			Metric cap screws 		
SAE grade No.	SAE GR.5 	SAE GR.8 	property class	8.8 Approx. SAE GR 5	
1/4	(N-m) 11.7 to 15.8 (kgf-m) 1.19 to 1.61 (ft-lbs) 8.6 to 11.6	(N-m) 16.3 to 19.8 (kgf-m) 1.66 to 2.02 (ft-lbs) 12.0 to 14.6	M6	(N-m) 9.8 to 11.2 (kgf-m) 1.0 to 1.1 (ft-lbs) 7.2 to 8.3	
5/16	(N-m) 23.1 to 27.8 (kgf-m) 2.35 to 2.83 (ft-lbs) 17.0 to 20.5	(N-m) 32.5 to 39.3 (kgf-m) 3.31 to 4.01 (ft-lbs) 24.0 to 29.0	M8	(N-m) 23.6 to 27.4 (kgf-m) 2.4 to 2.8 (ft-lbs) 17.4 to 20.2	
3/8	(N-m) 47.5 to 57.0 (kgf-m) 4.84 to 5.81 (ft-lbs) 35.0 to 42.0	(N-m) 61.0 to 73.2 (kgf-m) 6.22 to 7.46 (ft-lbs) 45.0 to 54.0	M10	(N-m) 48.1 to 55.8 (kgf-m) 4.9 to 5.7 (ft-lbs) 35.5 to 41.2	
1/2	(N-m) 108.5 to 130.2 (kgf-m) 11.06 to 13.28 (ft-lbs) 80.0 to 96.0	(N-m) 149.2 to 179.0 (kgf-m) 15.21 to 18.25 (ft-lbs) 110.0 to 132.0	M12	(N-m) 77.5 to 90.1 (kgf-m) 7.9 to 9.2 (ft-lbs) 57.2 to 66.5	
9/16	(N-m) 149.2 to 179.0 (kgf-m) 15.21 to 18.25 (ft-lbs) 110.0 to 132.0	(N-m) 217.0 to 260.4 (kgf-m) 22.13 to 26.55 (ft-lbs) 160.0 to 192.0	M14	(N-m) 124 to 147 (kgf-m) 12.6 to 15.0 (ft-lbs) 91.5 to 108.4	
5/8	(N-m) 203.4 to 244.1 (kgf-m) 20.74 to 24.89 (ft-lbs) 150.0 to 180.0	(N-m) 298.3 to 358.0 (kgf-m) 30.42 to 36.51 (ft-lbs) 220.0 to 264.0	M16	(N-m) 196 to 225 (kgf-m) 20.0 to 23.0 (ft-lbs) 145 to 166	
			M18	(N-m) 275 to 318 (kgf-m) 28.0 to 32.5 (ft-lbs) 203 to 235	
			M20	(N-m) 368 to 431 (kgf-m) 37.6 to 44.0 (ft-lbs) 272 to 318	

Top of bolt

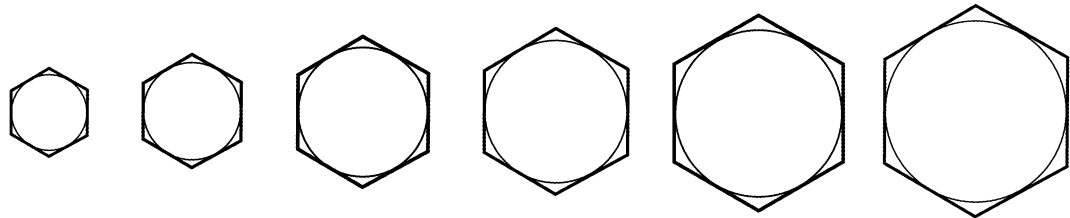

M6

M8

M10

M12

M14

M16

Length

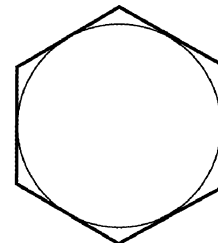
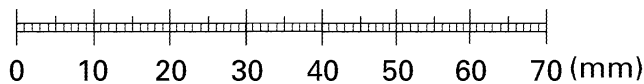

M18 M20

# REMOVING THE LOADER



## WARNING

To avoid serious injury:

- Make sure an approved bucket is attached before removing the loader from the tractor.
- For removing the loader, choose flat and hard ground, preferably concrete.
- If the ground surface is soft, place suitable planks on the ground for the bucket and stands.
- Before starting the engine or using the hydraulic control valve, always sit in the operator's seat.
- Make sure the bucket and stands are at ground level.

1. Raise the boom until the stands can be rotated.
2. Stop the engine.
3. Remove the spring pins holding the stands to the boom.
4. Slide the stands outward and rotate them until the hole in the stand and pin on the boom are aligned. Then slide the stands inward and insert the spring pin as shown.

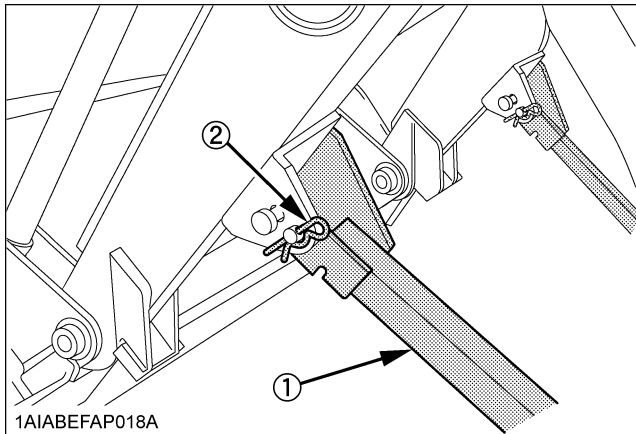

(1) Stand  
(2) Spring pin

5. Start the engine.
6. Dump the bucket approximately 20 degrees.
7. Lower the boom and raise the front wheels slightly.

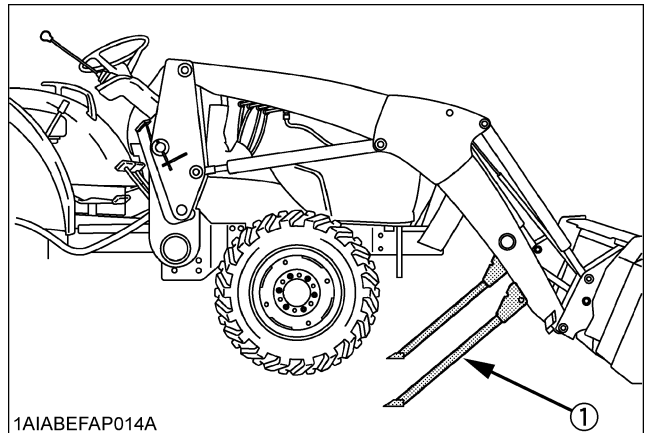

(1) Stand

## IMPORTANT :

- Lift the front wheels with the bucket. Do not attempt to lift them with the stands.
8. Stop the engine.
  9. Remove the mounting pins from the loader main frame and hold them on the side frames.
  10. Start the engine and run at idle. Slowly move the loader control lever to rollback position to raise the loader side frames up and out of the receivers of the main frames as shown.

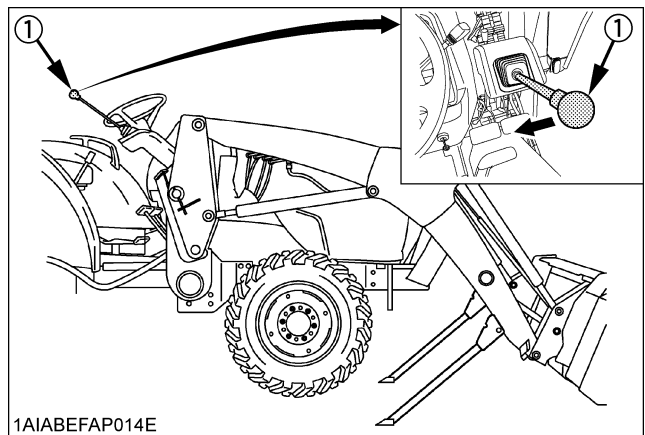

(1) Loader control lever

11. Stop the engine.
12. Slowly release all hydraulic pressure by moving the hydraulic control lever in all directions.
13. Disconnect the 4 hoses with quick couplers at the control valve and place them to the hose guide as shown.

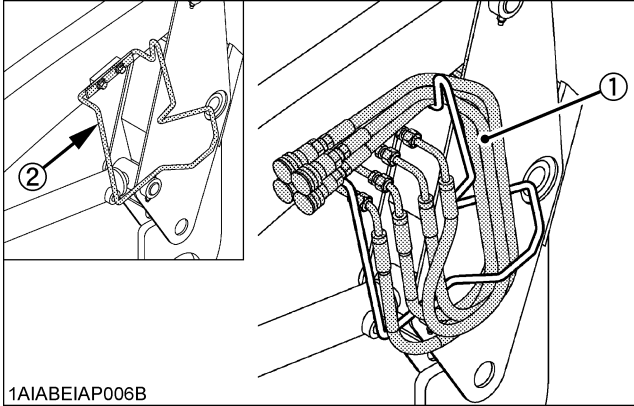

- (1) Hose
- (2) Hose guide

14. Place the protective caps and plugs on the quick coupler ends.

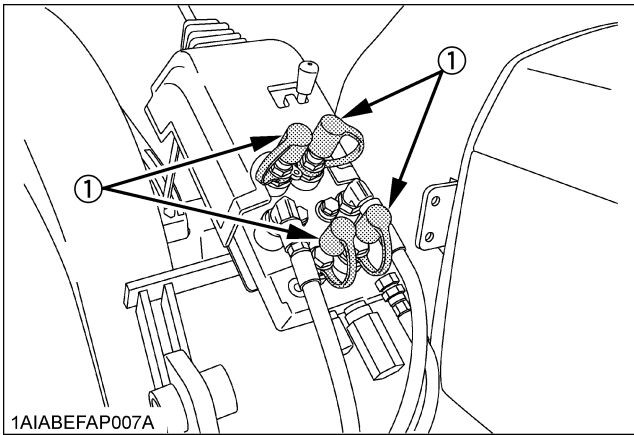

- (1) Protective caps

15. Start the engine and slowly back the tractor away from the loader.

---

# STORING THE LOADER

1. Store the loader in a clean dry place.
2. Make sure the loader is properly supported.
3. Attach the protective plugs and caps to the couplers to protect them from dust.

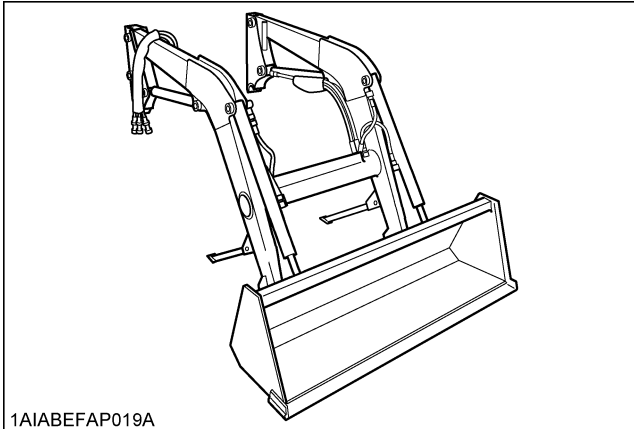

1AIABEFAP019A

4. Check all hydraulic hoses and connections. Repair or replace them if necessary.
  5. Repair or replace any worn, damaged or missing parts.
  6. Lubricate loader as described in "LUBRICATION" in Maintenance section.
  7. Apply a coat of grease to all exposed cylinder rods and mounting pins to prevent rust.
  8. Repaint worn or scratched parts.
-

# REINSTALLING THE LOADER



## WARNING

To avoid serious injury:

- Before starting the engine and operating the control valve, always sit in the operator's seat.

1. Slowly drive the tractor between the loader side frames until the rear portion of both side frames touches the main frames as shown.

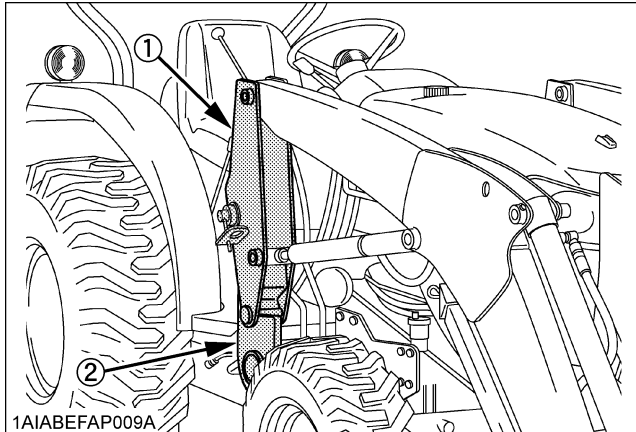

(1) Side frame  
(2) Main frame

2. Stop the engine.
3. Connect the four hoses with couplers to the nipples on the control valve as indicated with color marks. Then connect the protective caps and plugs to each other.

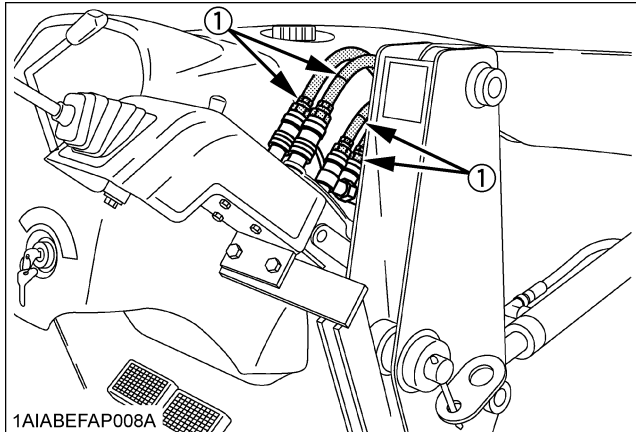

(1) Hoses

### NOTE :

- Adjust the route of the hoses as shown.

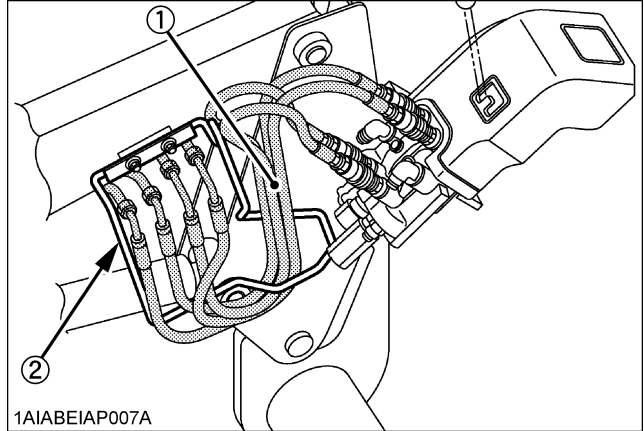

1AIABEIAP007A

(1) Hoses  
(2) Hose guide

4. Start the engine and run at idle.
5. Slowly move the loader control lever to dump position to lower the side frames into the main frames and engage the bosses of the side frames to the guide plates of the main frames. Then lift the weight off the front wheels with the loader - do not lift the wheels off the ground.

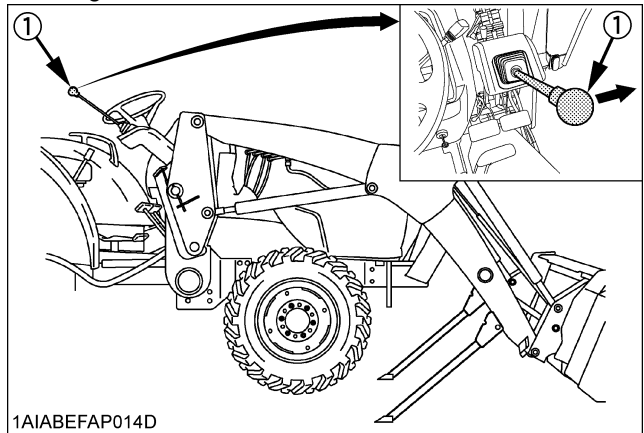

1AIABEFAP014D

(1) Loader control lever

### IMPORTANT :

- Do not attempt to lift the front wheels with the stands.
6. Stop the engine. Reinstall the mounting pins and insert the slide bar of the mounting pins to the hole of the side frame.
  7. Start the engine.
  8. Raise the boom until the stands can be rotated.
  9. Stop the engine.

10. Store the stands to their original positions and secure them with the spring pins as shown.

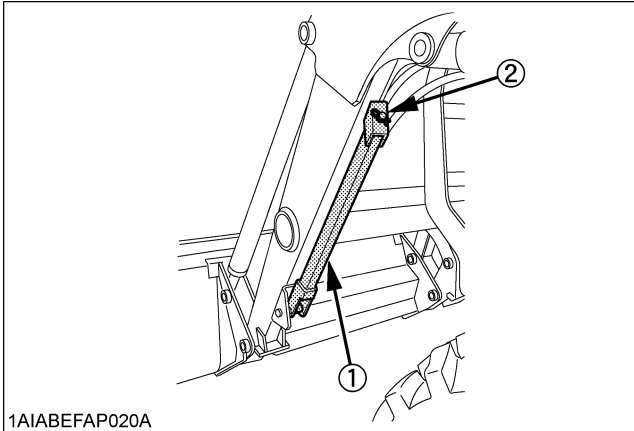

- (1) Stand  
(2) Spring pin

11. Start the engine.
12. Lower the boom and level the bucket.

## **KUBOTA Corporation is ...**

Since its inception in 1890, KUBOTA Corporation has grown to rank as one of the major firms in Japan.

To achieve this status, the company has through the years diversified the range of its products and services to a remarkable extent. Nineteen plants and 16,000 employees produce over 1,000 different items, large and small.

All these products and all the services which accompany them, however, are unified by one central commitment. KUBOTA makes products which, taken on a national scale, are basic necessities. Products which are indispensable. Products which are intended to help individuals and nations fulfill the potential inherent in their environment. KUBOTA is the Basic Necessities Giant.

This potential includes water supply, food from the soil and from the sea, industrial development, architecture and construction, and transportation.

Thousands of people depend on KUBOTA's know-how, technology, experience and customer service. You too can depend on KUBOTA.