



EARTHSOLAR
BILLBOARD LIGHT
 COMPACT SOLAR LED BILLBOARD LIGHT



GENERAL SPECIFICATIONS

Models	ETG-SBBLED05 / 10 / 15 / 20
Watts	5W / 10W / 15W / 20W
Solar Panel	5.5V Polycrystalline
Lumen Range	500 ~ 2000
IP Rating	IP65
CRI	>82
Material	Aluminium Housing
Beam Angle	270°
Charging time	6-8 Hours
Warranty	2 Years

FEATURES

- » Ultra Slim Compact Unit
- » Integrated Solar Panel and Battery
- » IP65 Water & Dust Proof
- » Light weight Aluminium Body
- » Integrated Battery Management System

APPLICATIONS

- High way Billboards
- Walk way Billboards
- Commercial signages
- Mounted Company Sign / Logo
- Public Signages

SPECIFICATION

MODEL	ETG-SBBLED05	ETG-SBBLED10	ETG-SBBLED15	ETG-SBBLED20
LED Lamp	5W	10W	15W	20W
Solar Panel	5.5V 5W Polycrystalline	5.5V 11W Polycrystalline	5.5V 13W Polycrystalline	5.5V 17W Polycrystalline
Light Source	Osram LED Chips			
CCT	3000K - 4000K- 6000K			
IP Rating	IP65			
Battery	3.7V 2200mAh Li-Ion Battery			
Charging time	6-8 Hours			
Discharging time	10-12 Hours			
Lumen (lm)	500lm	1000lm	1500lm	2000lm
lm/W	100lm/W			
Body Material	Aluminium + Polycarbonate Lens			
Install Height	2 - 3 Metre	2 - 3 Metre	3 - 5 Metre	3 - 5 Metre
Life span	50,000hrs			
Dimension	300 x 13 x 7.5mm	600 x 176 x 55mm	800 x 176 x 55mm	1050 x 176 x 55mm
Available colours	Modern Black / Silver			
Warranty	2 Years			



5W
Solar Panel 5.5V 5W



10W
Solar Panel 5.5V 11W



15W
Solar Panel 5.5V 13W



20W
Solar Panel 5.5V 17W

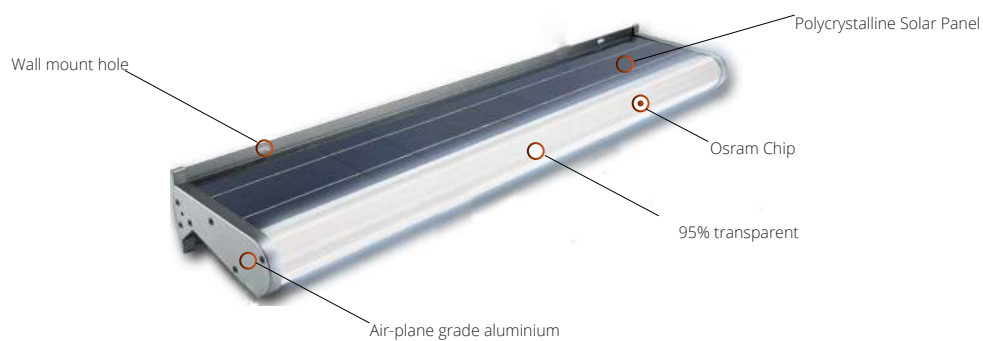

HOW IT WORKS

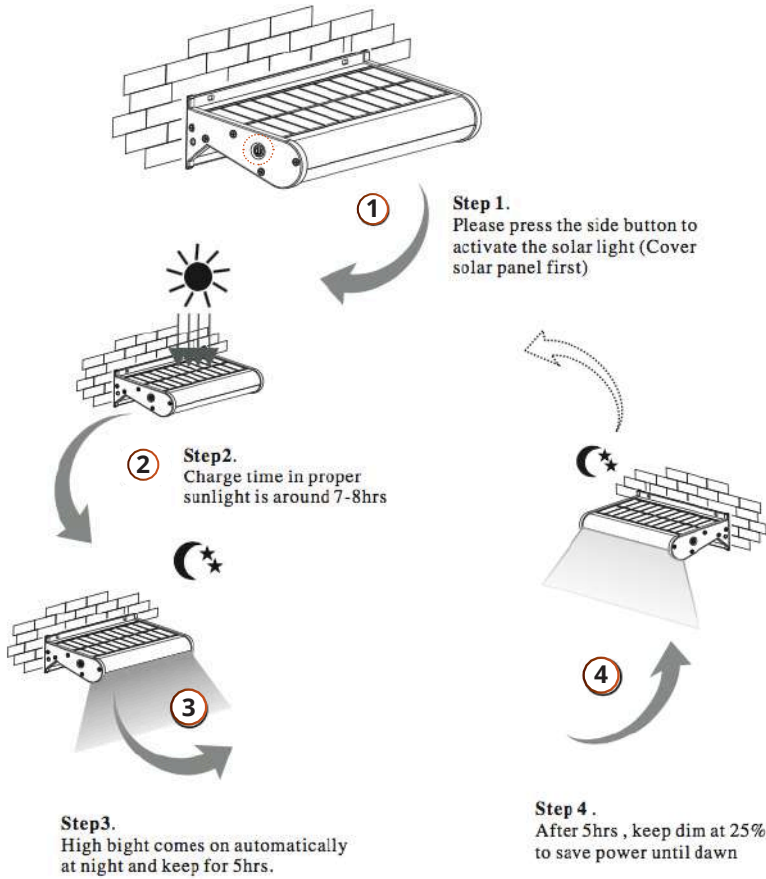

DISCLAIMER

Important Statement of warranty.

Earthtrack reserves the right to change or discontinue a product and / or specification without notice. All warranty periods only cover faulty workmanship and / or material components. Any claims on misused or disassembled products will not be recognized by Earthtrack. All information enclosed in this catalogue, to our knowledge, was correct at time of print.