

1 LITRE FOAM SOAP DISPENSER



HALO

- CONSTRUCTED IN ABS PLASTIC IN A CONTEMPORARY 'SILK TOUCH' SATIN WHITE/GRAPHITE FINISH.
- INTERCHANGEABLE METALLIC HALO VIEWING WINDOW.
- AVAILABLE IN EIGHT DIFFERENT COLOURS AND TINTS.
- SPIRIT LEVEL INSTALLED ON THE BACKPLATE TO AID INSTALLATION.
- TRANSLUCENT PUMP WITH MARINE GRADE STAINLESS STEEL SPRING.
- 1LTR RESERVOIR WITH FOAM PUMP. 0.25ML LIQUID EXPANDING TO 5ML FOAM.
- PRODUCT BRANDING AVAILABLE FOR ADDED PERSONALISATION.
- KEY OPERATED WITH EASILY DISTINGUISHABLE KEY.

WHAT COLOUR IS YOUR HALO?



SILVER

CODE:
HAL22
WSL



GRAPHITE

CODE:
HAL22
WGT



PEARL

CODE:
HAL22
WPL



ROSE GOLD

CODE:
HAL22
WRG



GOLD

CODE:
HAL22
WGD



SAPPHIRE

CODE:
HAL22
WSP



EMERALD

CODE:
HAL22
WED



RUBY

CODE:
HAL22
WRB

DIMENSIONS IN MM:-

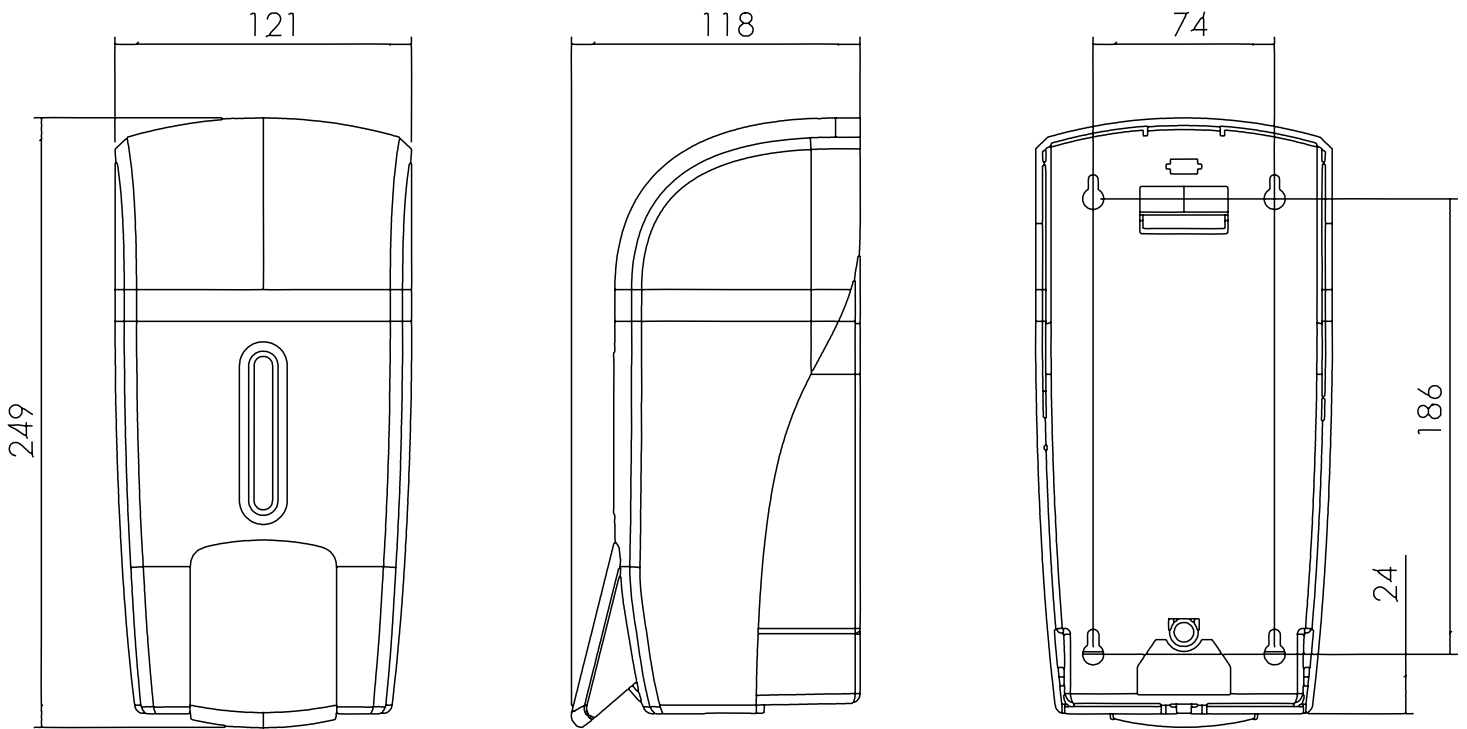

OPEN VIEW OF DISPENSER:-

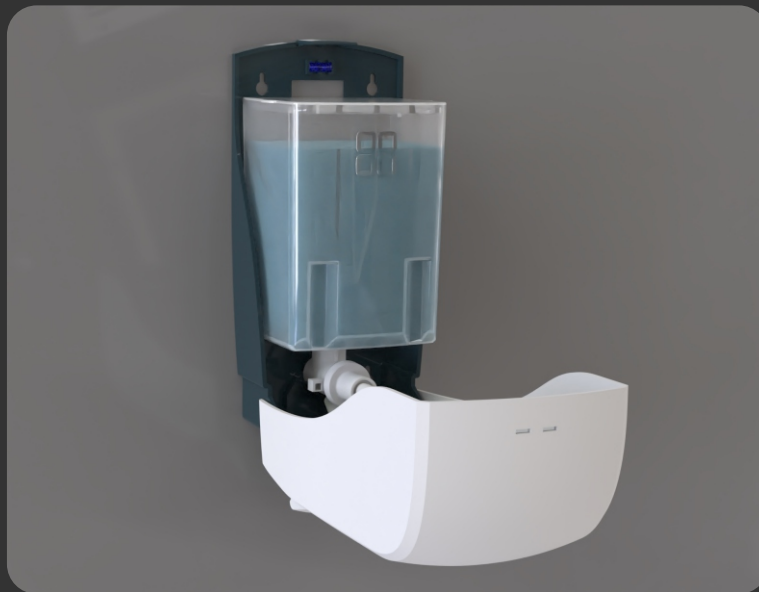

THE SYMBOL OF A GENUINE HALO DISPENSER