



Easy Boom

QUICK START GUIDE



Setup Guide & Video

Scan this code or visit [fjwestcott.com/manuals](https://www.fjwestcott.com/manuals) to access the user manual and video. Be sure to follow all safety and assembly instructions carefully before using the Easy Boom.

Important Safety Information

- Prior to attaching or detaching a light or counterweights from the Easy Boom, **ALWAYS** ensure the locking pin is securely inserted through the boom arm and center column while the Easy Boom is in its horizontal position. Failure to do so may damage equipment or, in some cases, cause bodily injury.
- Use caution and ensure the Easy Boom is adequately supported during all equipment adjustments or movement of the Easy Boom to maintain safety and prevent accidents.
- **NEVER** operate the Easy Boom without properly tethering your light to the Easy Boom using the included safety wire. This safety precaution is essential for preventing accidental falls and ensuring the safety of equipment and individuals.
- Confirm the secure installation of your light head onto the 5/8" baby pin by tightening the light head's tension knob onto the flat side of the 5/8" baby pin.
- Prior to use, securely mount the Easy Boom onto a C-Stand with the light head positioned parallel to the C-Stand's longest leg. This setup is crucial for both safety and optimal performance. Failing to align the Easy Boom correctly may compromise stability and functionality, potentially leading to accidents.



Locking Pin

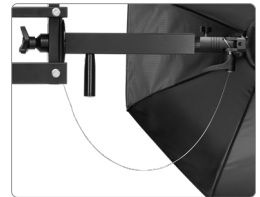

Safety Wire

Warning

- Never leave unattended around children and/or pets.
- Keep away from fire, water, and moisture. Do not submerge in water.
- Do not attempt to modify any Westcott products. Contact Westcott for assistance.

Included Parts & Components



Easy Boom



Locking Pin



Extension Arm



Coned-Shaped Spacer



Washer



Tension Knob



(3) Counterbalance
Thumbscrews



Weight Bag (Empty)

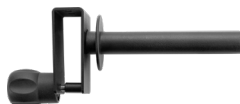

Weight Plate Bracket



Weight Plate Clamp



Safety Wire
(39.5")

Assembly

1. Unpack all items from the box and place them on a flat surface. **Do not mount the Easy Boom onto a C-Stand until assembly is finished.**
2. Find the extension arm and carefully insert the bolt into the front support bar of the Easy Boom.
3. Attach the cone-shaped spacer onto the bolt, ensuring the larger end is against the vertical support bar. Slide the included washer onto the cone-shaped spacer.
4. Secure the extension arm to the support bar by fastening the tension knob onto the bolt and rotating it clockwise until snug. **Do not overtighten.**
5. Lay the Easy Boom horizontally on a flat surface. Attach the locking pin by pressing the button on the pin and inserting it through the center column and the half-circle-shaped support plate. Ensure the locking pin is fully inserted and its head is flush with the support plate.

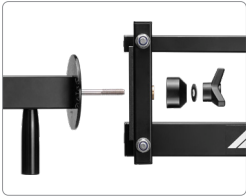

Steps 2-3

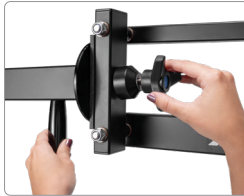

Step 4



Step 5



Step 5

Mounting to a C-Stand

Important Preparations:

- Verify the Easy Boom is assembled and in the horizontal position with its locking pin securely installed.
- Remove all mounted equipment and counterweights from the Easy Boom.

Mounting:

1. Loosen the tension knob located at the base of the center column. The Easy Boom features 2 threaded tension knob holes to accommodate various C-Stand baby pin styles.
2. Carefully lift the Easy Boom with both hands, aligning its receiver with the C-Stand's Baby Pin. Lower it into place, ensuring the extension arm is positioned over the largest leg of the C-Stand for increased stability.
3. With the Easy Boom in the horizontal position, tighten the tension knob to ensure it is securely attached to the C-Stand.



Step 1



Step 2



Equipment Mounting with Weight Bag Counterbalance

Important Preparations:

- Weigh the equipment you plan to mount (up to 15 lbs).
- Fill the weight bag with lead shot (sold separately) to match your equipment weight plus 3.2-3.5 lbs for optimal counterbalance.
- Verify the Easy Boom is in the horizontal position and its locking pin is securely installed.
- Remove all mounted equipment, counterweights, and thumbscrews from the Easy Boom.

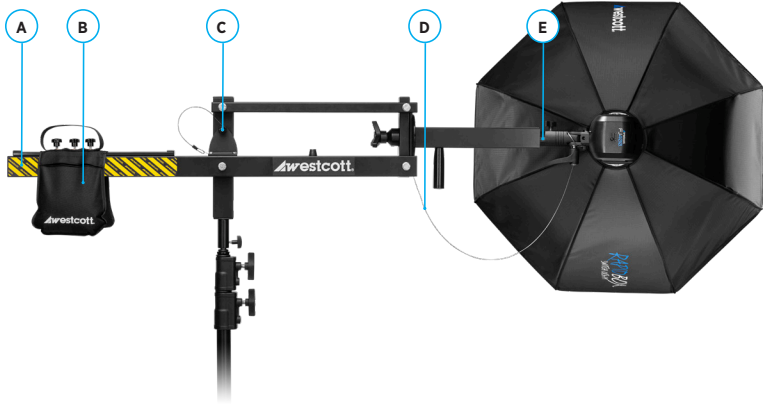

- A. Easy Boom's Tail End
- B. Weight Bag
- C. Locking Pin
- D. Safety Wire
- E. 5/8" Baby Pin
- F. Counterbalance Track Runner
- G. Counterbalance Thumbscrews (3)

Assembly:

1. Slide the counterbalance track runner to the end of the track furthest from the center column.
2. Locate the 3 counterbalance thumbscrews.
3. Align the rivets at the top of the weight bag with the 3 thumbscrew holes on the counterbalance track runner.
4. Secure the weight bag to the counterbalance track by inserting the 3 thumbscrews into place. **Do not overtighten.**
5. Mount your light head to the Easy Boom using the 5/8" baby pin. Tighten the light's tension knob to secure into place.
6. Wrap the included safety wire around your light's tilter bracket, above the handle, or another secure area.
7. While supporting the Easy Boom's tail end, press the release button on the locking pin and pull it away from the center column. Gently adjust the tail end up or down as needed to facilitate the insertion or removal of the locking pin. Store the locking pin in the plastic cap located on top of the center column.
8. To adjust the counterweight, loosen the 3 thumbscrews and slide the weight bag back and forth along the rear arm.



Step 1



Step 4



Step 5

Equipment Mounting with Weight Plate Counterbalance

Important Preparations:

- Weigh the equipment you plan to mount (up to 15 lbs).
- The included weight plate bracket can hold weight plates (sold separately) up to 18.5 lbs., with center openings between 1" and 2" in diameter.
- Use weight plates to match your equipment weight plus 3.2-3.5 lbs for optimal counterbalance.
- Verify the Easy Boom is in the horizontal position and its locking pin is securely installed.
- Remove all mounted equipment, counterweights, and thumbscrews from the Easy Boom.

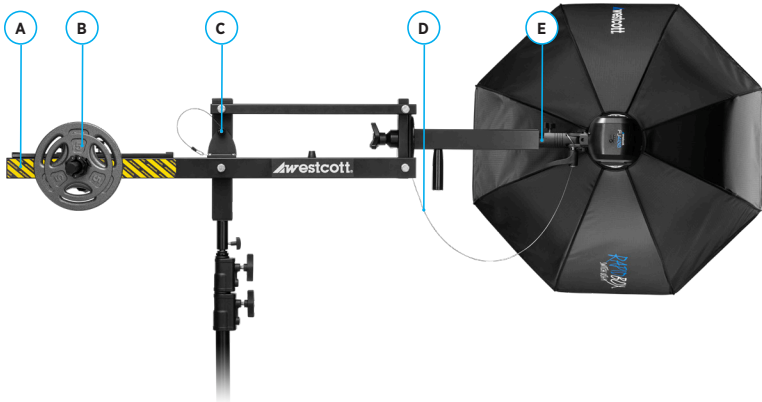

- A. Easy Boom's Tail End
- B. Weight Plates (Sold Separately)
- C. Locking Pin
- D. Safety Wire
- E. 5/8" Baby Pin
- F. Counterbalance Track Runner
- G. Weight Plate Bracket
- H. Counterbalance Thumbscrew
- I. Weight Plate Bracket Arm
- J. Weight Plate Clamp
- K. Weight Plate Bracket Knob

Assembly:

1. Locate the weight plate bracket and loosen the knob located at its base. Do not fully remove the set screw.
2. Stand at the tail end of the Easy Boom. Position the weight plate bracket so its arm faces the right side (shown above), then slide the bracket onto the tail end of the boom.
3. Align the 2 holes in the center of the weight plate bracket with the 2 pegs on the counterbalance track. Once aligned, lower the bracket onto the track.
4. Slide the counterbalance track runner to the Easy Boom's tail end. Tighten the knob at the base of the weight plate bracket to secure it in position.
5. Insert 1 counterbalance thumbscrew into the thread located between the 2 pegs on the weight plate bracket. Store the remaining two thumbscrews in the unused set screw holes on the counterbalance slider.
6. Place sufficient weight plate(s) onto the weight plate bracket's arm to properly counterbalance the equipment you plan to mount.
7. Locate the weight plate clamp. Open its lever and slide the clamp onto the weight plate bracket's arm until it sits flush with the mounted weight plates.
8. Close the lever to secure the clamp onto the weight plate bracket's arm.
9. Mount your light head to the Easy Boom using the 5/8" baby pin. Tighten the tension knob.
10. Wrap the included safety wire around your light's tilter bracket, above the handle, or another secure area.
11. While supporting the Easy Boom's tail end, press the release button on the locking pin and pull it away from the center column. Gently adjust the tail end up or down as needed to facilitate the insertion or removal of the locking pin. Store the locking pin in the plastic cap located on top of the center column.
12. Loosen the knob and the middle thumbscrew to slide the weight plate bracket back and forth along the tail end, adjusting the counterweight as needed.

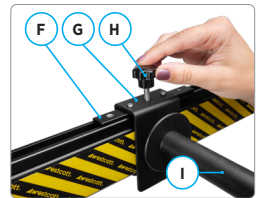

Step 5



Step 8

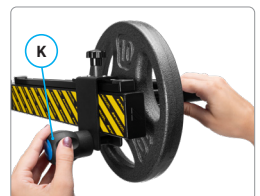

Step 12

Adjusting the Vertical Position

Important Preparations:

- Verify the light head is securely attached and tethered to the Easy Boom via the included braided safety wire.
- Confirm that the counterbalance weight is securely attached, using an adequate weight based on the mounted equipment.



Adjustment Procedure:

1. Hold the tail end of the Easy Boom with 1 hand.
2. With your other hand, grasp the locking pin, press the release button, and pull the pin away from the center column. Gently adjust the tail end up or down as needed to facilitate the insertion or removal of the locking pin.
3. Slowly remove your hand from the Easy Boom. A properly balanced Easy Boom should maintain a horizontal position without the need for any additional support.
4. Using the weight plate bracket's arm, slowly move the extension arm up and down to reach your desired position.



Rotating a Light Head

1. Locate the extension arm tension knob on the Easy Boom.
2. Loosen the knob by rotating it $\frac{1}{4}$ -turn counterclockwise. **Never rotate the tension knob more than a $\frac{1}{2}$ -turn counterclockwise, as this could cause the extension arm to detach from the Easy Boom.**
3. Using the handle, slowly rotate the extension arm to your desired position.
4. Once in position, rotate the knob clockwise to tighten and lock the extension arm in place. **Do not overtighten.**



Steps 2-3

IMPORTANT: Never make more than 1 full rotation in any direction. Doing so may inadvertently loosen or overtighten the extension arm connection to the Easy Boom.



Removing From a C-Stand

1. Adjust the Easy Boom into the horizontal position.
2. Verify that the locking pin is correctly installed.
3. Disconnect the tethered safety wire from the light head and carefully remove it from the Easy Boom.
4. Detach the counterbalance by either removing the weight plates and the weight plate bracket, or by removing the weight bag.
5. Turn the tension knob counterclockwise to loosen the Easy Boom's attachment to the C-Stand.
6. With both hands, carefully lift the Easy Boom up and away from the C-Stand. Then place it on a flat surface.

Warranty

Westcott's warranty obligations for this product are limited to the following terms.

The F.J. Westcott Co. ("Westcott") warrants this Westcott branded product against defects in materials and workmanship under normal use for a period of ONE (1) YEAR from the date of retail purchase from Westcott or an authorized retailer by the original end-user purchaser ("Warranty Period"). If a defect arises and a valid claim is received within the Warranty Period, at its option and to the extent permitted by law, Westcott will either (1) repair the defect at no charge, using new or refurbished replacement parts, or (2) exchange the product with a product that is new or which has been manufactured from new or serviceable used parts and is at least functionally equivalent to the original product. This Limited Warranty applies only to products manufactured by or for Westcott that can be identified by the Westcott trademark, trade name, or logo affixed to them.

This warranty does not apply to: (a) damage caused by accident, abuse, misuse, flood, fire, earthquake, mold, or other external causes; (b) damage caused by operating the product outside the permitted or intended uses described by Westcott; (c) a product or part that has been modified to alter functionality or capability without the written permission of Westcott; or (d) cosmetic damage, including but not limited to scratches, dents and broken plastic.

Disclaimer: By purchasing, borrowing and/or using this product for any event, both public or private, you, the customer, accepts all responsibility and releases Westcott, and its associates, of any and all liability in the event of manufacturer's defect, malfunction or misuse of the product which may lead to further injuries or complications unforeseen by the user. Westcott is not responsible for any potential or incurred damage caused by failure to properly mount, hang, or store the product, which includes, but is not limited to damage to cameras, electronics, electrical equipment, buildings, building materials, personal injury, death, or disability, fire damage, or any and all other damage not mentioned previously.

Please contact Westcott Customer Support for a Return Authorization Number "RMA" prior to requesting warranty service. This RMA must be clearly written on the outside of the box to the left of the shipping label. Items sent in without pre-authorization or that do not fall under the limited warranty will be returned at the expense of the sender.

Phone: 419-243-7311

Email: support@fjwestcott.com

Shipping: F.J. Westcott Co, 1425-B Holland Rd. Maumee, OH 43537

Register your new gear online at [FJWESTCOTT.COM/REGISTER](https://www.fjwestcott.com/register)

Visit [WESTCOTTU.COM](https://www.fjwestcott.com) for videos, pro tips, inspiration, and more!

Westcott products are made to the company's traditionally high standards of quality and comply with all applicable government safety regulations and requirements. In an effort to provide the best quality products possible, we periodically make product modifications. Actual products may not be identical to items pictured. Made in China. ©F.J. Westcott Co. All rights reserved. E0524