

1788 Easy chair

By Hans J. Wegner, 1974

Model	1788 - Easy chair with buttons
About	Wegner designed the sophisticated 1788 armchair in 1974. The lightweight wooden design with interchangeable cushions is ideal for both exclusive public spaces and private homes.
Product group	Lounge chairs
Measurements	25.79" W x 27.56" D x 34.56" H Seat: 17.13" H
Weight	10 kg
Materials	Frame of solid wood. Seat supported by jute webbing. Interchangeable seat and back cushion with buttons. Back cushion attached with leather straps.
Accessories	Glides with or without felt. Cushions in leather or fabric according to current price list. COM fabrics upon factory approval. (P1788)
Test & certificates	Oak is FSC® certified
Guarantee	Fredericia Furniture A/S offers a 7 year guarantee against manufacturing defects in standard products (materials and construction). Wear and damage to covers, surface treatment, inappropriate use and the like are not covered by the warranty.
Download	Click here to download images, architect files at our partner portal.



DRAWING

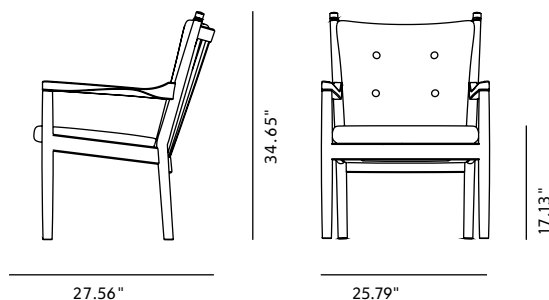

WOOD



BLACK
LACQUERED



OAK OIL, FSC
MIX 70%



OAK SOAP,
FSC MIX 70%

Upholstery according to current price list.