

**Operating manual**  
**High-pressure cleaner**

- GB -

**quadro 11/140 TST**  
*11 l/min / 140 bar*

**quadro 12/150 TST**  
*12 l/min / 150 bar*

**quadro 9/170 TST**  
*9 l/min / 170 bar*



**Read and conform safety instructions before use!**  
**Keep instructions in a safe place for later use and pass them on to any future user.**



## Technical data

Technical data	quadro 9/170 TST	quadro 11/140 TST	quadro 12/150 TST
Operating pressure, steplessly adjustable	10 - 170 bar	10 - 140 bar	10 - 150 bar
max. permissible overpressure	190 bar	155 bar	165 bar
*1 Water output at nominal pressure	8.7 l/min	11.0 l/min	12.0 l/min
Nozzle size			
(Flat jet)	2503	25045	25045
(Dirt killer)	03	045	045
Volume			
Water tank	7 l	7 l	7 l
Inlet water temp. to water tank	max. 60 °C	max. 60 °C	max. 60 °C
Max. temp. for direct suction	60 °C	60 °C	60 °C
*2 Direct suction height	2.5 m	2.5 m	2.5 m
Hose drum	yes	yes	yes
High pressure hose	15 m	15 m	15 m
Electrical ratings	230 V/50 Hz, 14 A	230 V/50 Hz, 14 A	400 V/50 Hz, 7 A
Motor speed adjust.	1400 rpm	1400 rpm	1400 rpm
Connect.wattage Inp.	P1: 3.1 kW	P1: 3.1 kW	P1: 3.1 kW
Output	P2: 2.3 kW	P2: 2.3 kW	P2: 2.5 kW
Weight (incl. access. with empty water tank)	45 kg	45 kg	45 kg
Dimensions ind. handle L x W x H in mm	590 x 360 x 850	590 x 360 x 850	590 x 360 x 850
Sound level acc. to DIN 45 635 (reg. working place)	84 dB (A)	84 dB (A)	88 dB (A)
with dirtkiller	89 dB (A)	89 dB (A)	90 dB (A)
Guaranteed sound level $L_{WA}$	88 dB (A)	88 dB (A)	88 dB (A)
Vibrations at lance	2,0 m/s <sup>2</sup>	2,0 m/s <sup>2</sup>	2,1 m/s <sup>2</sup>
Recoil at lance	approx. 20 N	approx. 20 N	approx. 20 N

Permissible tolerance for figures ± 5 % in acc. with VDMA uniform sheet 24411

\*1 **Min. water quantity to be supplied to the high pressure cleaner!**  
(2-8 bar admission pressure)

\*2 **Direct suction is possible through by-passing of water tank!**  
(see page 13)

## Description

### Dear customer

We would like to congratulate you on your new high pressure cleaner with integrated water tank and to thank you for the purchase.

To ease your introduction to the use of the cleaner, we have provided the following pages of explanations, tips and hints, which we ask you to read before using it for the first time.

The equipment will assist you professionally in all cleaning tasks, e.g.:

- **facades**
- **vehicles of all types**
- **barrels and containers**
- **flagstones**
- **stables**
- **channels**
- **terraces**
- **machines etc.**

<u>Contents</u>	Page
Technical data .....	2
Connection principle and components .....	4
Water system .....	5
Detergent / caring system .....	5
Lance and spay gun .....	5
High pressure hose and spray device .....	6
Unloader valve - safety valve .....	6
Total stop system .....	7
Setting up / Location .....	7
Electrical connection .....	8
Brake .....	9
Brief operating instructions .....	9
This is what you've purchased .....	10
Preparation for use .....	11
External suction .....	13
When using detergents .....	14
To shut down the pump / Frost protection .....	14
Safety notes „This is prohibited !“ .....	15
Additional accessories .....	18
Small repairs .....	20
Spare parts lists .....	22
Wiring diagram .....	44
General rules / oil change / guarantee .....	46
Declaration of conformity .....	47
Inspection report .....	48

## Description

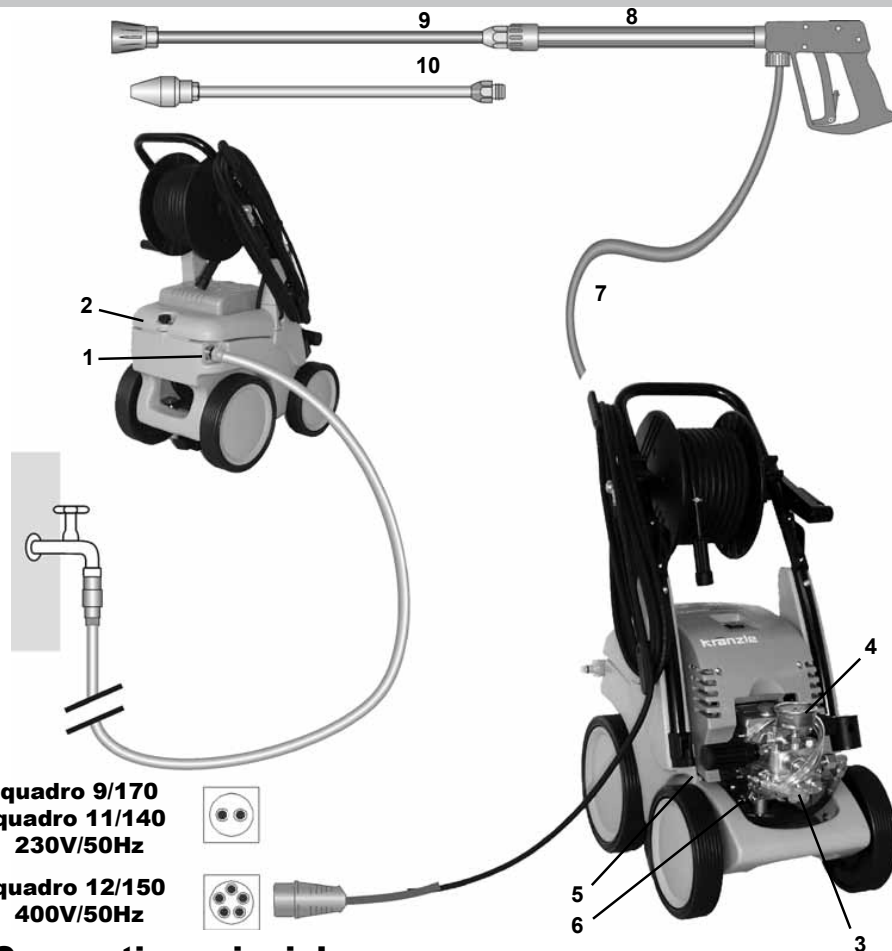

**quadro 9/170**  
**quadro 11/140**  
**230V/50Hz**



**quadro 12/150**  
**400V/50Hz**



### Connection principle

The KRÄNZLE quadro 9/170; 11/140 and 12/150 - high pressure cleaners are mobile machines with hose drum and 20 m industrial hose.

The connection principle can be seen from the illustration.

### Components

- 1 Water inlet connection with filter
- 2 Cover for water tank
- 3 High pressure pump
- 4 Press. gauge with glycerin filling
- 5 Unloader valve - safety valve

- 6 Detergent valve
- 7 High pressure hose
- 8 Spray gun
- 9 Interchangeable lance with flat jet nozzle and nozzle protection
- 10 Interchangeable lance with dirtkiller



## Description

### Water supply system

The water must be lead to the high pressure cleaner under pressure (2 – 8 bar ad-mission pressure). A float valve regulates the water inlet. Then, the water is sucked by the high pressure pump from the water tank and supplied to the lance under the set pressure. The high pressure jet is formed by the nozzle at the end of the lance.

### Detergent and caring system

The high pressure pump can also suck a detergent/caring agent and mix it with the high pressure jet. The additive is sucked through the pump and brought in with the set pressure.

Insert the detergent hose into the detergent container and open the detergent valve (6). The detergent must have the ph-value 7-9 neutral.

The detergent discharges with the water at the high pressure nozzle.



6



**Only open the dosing valve, if the chemistry sieve is placed in a liquid. Sucked air leads to destruction of the pump seals !!!**  
**The rules concerning the environment, refuse and ground water protection must be complied with!**

### Lance with spray gun

The machine can only be operated when the safety trigger is squeezed.

When the lever is squeezed, the spray gun opens. The liquid is then pumped to the nozzle. The spray pressure increases and quickly reaches the selected operating pressure. For the deairing of the system open and close the gun quickly a few times. When the trigger is released, the trigger gun closes and any further spraying of liquid from the lance is stopped and the pressure gauge must show 0 bar.

The increase in pressure when the trigger gun is closed causes the unloader valve-safety valve to open. The pump remains switched on and continues to pump liquid through the pump at reduced pressure. When the spray gun is opened, the unloader valve - safety valve closes and the pump resumes spraying from the lance with the selected operating pressure.



**The spray gun is a safety device. Repairs should only be performed by qualified persons. Should replacement parts be required, use only components authorized by the manufacturer.**

## Description

### High pressure hose and spraying device

The high pressure hose and spraying device supplied with the machine are made of high grade material. They are also optimized for the machine and marked as required by the appropriate regulations.



*If replacement parts are required, only such parts that are authorized by the manufacturer and which bear the markings required by the appropriate regulations may be used. The high pressure hose and spraying device must be connected in a pressure-tight manner. The high pressure hose may not be driven over, pulled excessively or twisted. Hose lines are wear parts. Guarantee is accepted only for manufacturing errors, not for external damages. High pressure hose lines and spraying equipment must not be repaired, but replaced by a new hose or spraying equipment.*

### Unloader valve - safety valve

The unloader valve - safety valve protects the machine from a build up of excess pressure, and is designed not to permit an excess pressure to be selected for operation. The limit nut on the handle is sealed with a spray coating.



The operating pressure and spray rate can be steplessly adjusted by turning the handle.

**Replacements, repairs, new adjustments and sealing should only be performed by qualified persons.**



**Take care that all screw connections are pressure-tight. A leakage of gun, high-pressure hose or hose drum has to be repaired at once. Leakages lead to an increased wear and to a possible malfunction of the delayed motor cut-out.**



#### **Operator's task:**

**Prior to each usage of this liquid spraying device, the operator is obliged to check if all safety relevant parts are in perfect working condition. (e.g. safety valves, high-pressure hose, cables and connections, spraying devices, etc. )**

## Description



### With Total-Stop-System

The Kränzle quadro 9/170 TS, 11/140 TS und 12/150 TS - high pressure cleaners are equipped with a Total-Stop-System.

If the main switch is switched on, the motor is started by means of a pressure switch as soon as the gun is operated. The pump quickly reaches the set operating pressure. When the gun is closed the motor is cut off immediately.



Replacements and inspection work should only be performed by qualified persons **when the machine is disconnected from the power supply, i.e. the plug pulled out from the electrical socket.**

### Setting up



#### Location

Neither set up and operate the machine in rooms where there is a risk of fire or explosion nor put it into puddles. Do not use the machine under water. The device must not stand in the spray area of the high pressure jet.

### CAUTION !



Never suck in liquid containing solvents such as paint thinners, petrol, oil or similar liquid matter. **Pay attention to the instructions of the manufacturers of the cleaning agents.** The seals in the machine are not resistant to solvents! The spray of solvents is inflammable, explosive and poisonous.

### CAUTION !



When running your high pressure cleaner with hot water of 60° C raised temperatures occur. **Do not touch the machine without safety gloves!**

## Description

**quadro 9/170**  
**quadro 11/140**  
**230V/50Hz**



**quadro 12/150**  
**400V/50Hz**



### Electrical connection

The machine is supplied with an electrical power cord with plug.

The mains plug must be fitted to a standard grounded socket with a **30mA** residual current operated device. The socket must be protected with a **16A delay** action fuse on the mains side.

**KRÄNZLE quadro 9/170 TST, 11/140 TST = 230 Volt / 50 Hz**

**KRÄNZLE quadro 12/150 TST = 400 Volt / 50 Hz**

(phase-sequence not significant)

When using an extension cable, this must have a grounded lead which is properly connected to the socket. The conductors in the extension cable must have a minimum cross section of 1.5 mm<sup>2</sup>. Plug connections must be of a spray-proof design and may not be located on a wet floor.

### **CAUTION !**

The use of extension cables which are too long may lead to malfunctions and start up difficulty. If the extension cable is longer than 10 m it must have a minimum cross section of 2.5mm<sup>2</sup>.

When using a cable drum, always keep the cable unwound as far as possible.

## Description



### Brake



Brake not applied



Brake applied

### Brief operating instructions:

1. Connect high pressure hose with spray gun.
2. Connect to suitable water supply.
3. Connect current (see page 8).
4. Switch on machine, operate gun and start cleaning.
5. After having completed the cleaning process, put main switch in zero position and by opening the gun, reduce the pressure in the high pressure hose.

Then, the high pressure hose can be rolled up.

- Only use clean water ! Protect from frost !

### **CAUTION !**

Please pay attention to the regulations of your waterworks company.

Due to the water tank, the device can be connected to any drinking water line without any difficulties.

*This is what you've purchased:*



**1. Dirtkiller**

Lance with nozzle protection and high pressure nozzle  
Flat jet 25°



**2. Spray gun M2000**  
with insulated handle and screw connection

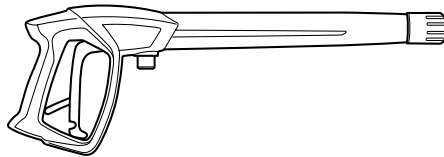

**3. KRÄNZLE - High pressure cleaners**  
quadro 9/170, 11/140 and 12/150 TST with hose drum and  
15 m HP hose NW 6 with steel reinforcement

**4. Operating manual**



**5. HP hose 15 m NW 6 with hose drum**



**6. Collapsible crank for hose drum**  
(already installed)

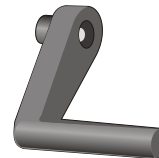

**7. Plug-in connection of water inlet parts and filter**  
(already installed)



## ***Preparation for use***



To control the high pressure cleaner  
**put**  
**1. the foot against the tilt bases and**  
**2. then pull the device towards you.**



**1. Check oil level.**

**The oil level must be between the  
two markings on the oil dipstick.**

## Preparation for use

2. Connect the high pressure lance or dirtkiller to the spray gun.

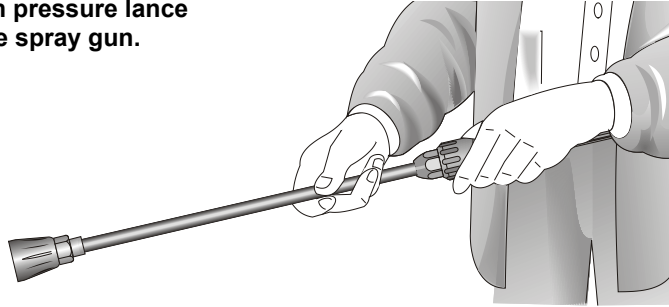

3. Unroll hose without kinks and connect with handgun and pump. Use max. 20 m HP hose.

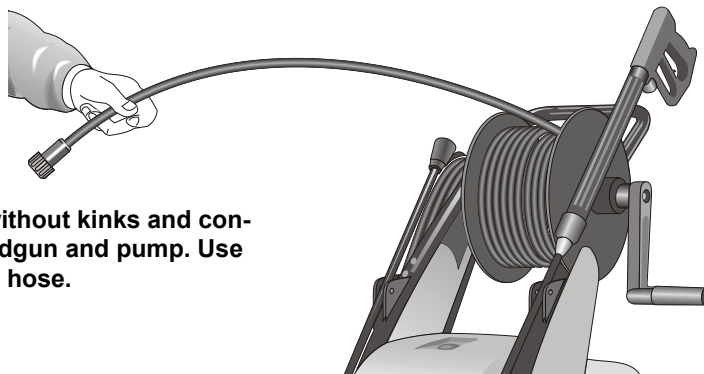

4. Connection of high pressure hose from device to lance.

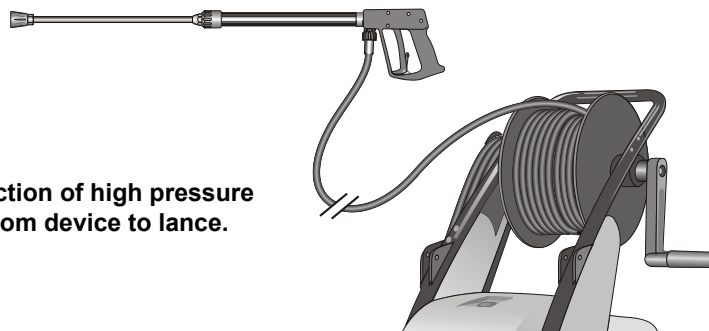



## Preparation for use

5. The machine must be connected to the water line with cold water or up to 60° C warm water (see page 2).

The hose cross section must be at least 3/4" = 16 mm (free passage). Filter 1 must always be clean.

Please make sure that the filter is clean before using your high pressure cleaner.



### CAUTION !



When running your high pressure cleaner with hot water of 60° C raised temperatures occur.

**Do not touch the pump without safety gloves!**

### External suction



Undercarriage

If water is to be sucked from an external container for the high pressure cleaner, the connection hose between the high pressure pump and the water tank must be screwed off and the suction hose must be connected



Undercarriage

via a double nipple 3/4" (Order no.: 46.004) to the connection hose.

Make sure that the water is clean. Use the Kränzle suction hose with suction filter. (Order no. 15.038 3)

**Maximum suction height 2.5 m, maximum water temperature for direct suction: 60°C**

(see technical data on page 2)

## To shut down the pump

### Suction of detergents

Put chemistry sieve number 5 into the detergent container. Open the detergent valve (6), then the detergent is sucked in. When closing the detergent valve, the chemistry supply is automatically closed. Allow detergent to act and then wash off. (see page 5).

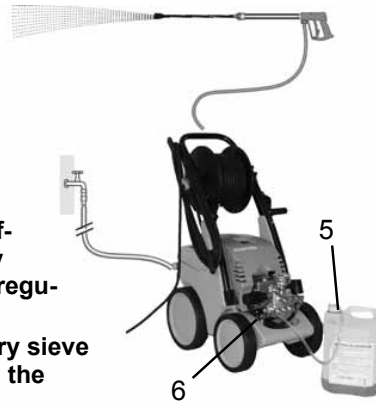

**Note that you must always comply with the instructions provided by the manufacturer of the detergent (e.g. safety clothing) and the water protection regulations!**



**Only open the valve, if the chemistry sieve is in a liquid. Sucked in air leads to the destruction of the pump seals !!!**  
Damages to the pump caused by sucked in air are not covered by the guarantee.

*To shut down the pump:*

1. Switch off the machine. Switch to „0“ position.
2. Cut off the water supply.
3. Open the spray gun briefly until the pressure is released.
4. Apply the safety catch on the spray gun.
5. Remove the water hose and spray gun.
6. Pull the plug from the socket.
7. Winter: store the pump in rooms above 0°C.
8. Clean the water filter.

### Frost protection

Normally after operation, there is still some water in the device. Thus, you must take special measures to protect the device from frost.

#### - Completely drain the device

For this purpose, separate the device from the water supply. Then, turn on the main switch and open the gun. Now, the pump presses the remaining water out of the water tank and the pump. However, do not allow the device to operate without water for longer than one minute.

#### - Fill the device with antifreeze agent

If the device is not operated for longer periods, especially over the winter, you should pump an antifreeze agent through the device. For this purpose, fill the antifreeze agent into the water box and turn on the device. Wait with opened gun, until the agent spurts out of the nozzle.

**However, the best way to protect the device from frost is to store it at a frost-free location.**

## Safety notes

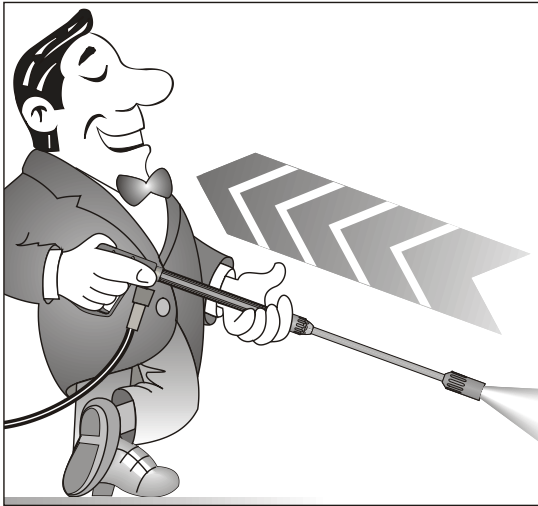

**As to the recoil -  
see notice on page 2!**

**Apply the safety catch on the  
spray gun after each use, in  
order to prevent unintentional  
spraying!**

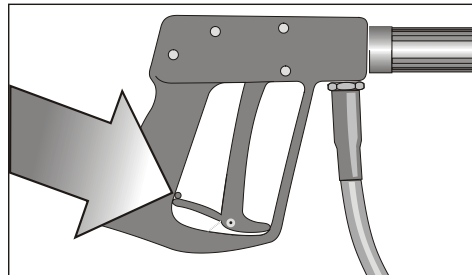

*This is prohibited !*



**Never direct the water jet at people or animals !**

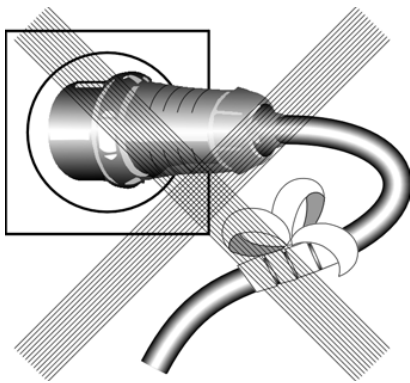

**Do not damage the power cable or repair it incorrectly!**



**Never pull the high pressure hose if it has formed kinks or "nooses"!  
Never pull the hose over sharp edges !**

*This is prohibited !*



**Never allow children to use the high pressure cleaner !**



**Never direct the water jet at the machine itself !**

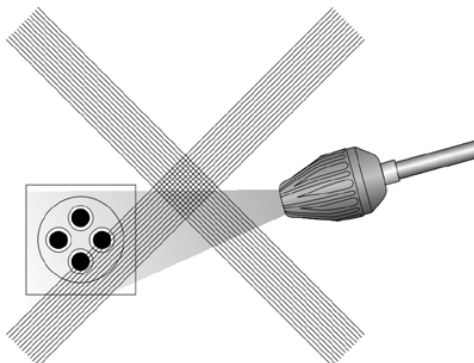

**Never direct the water jet at a power socket !**

*Additional accessories for ...  
(on demand)*

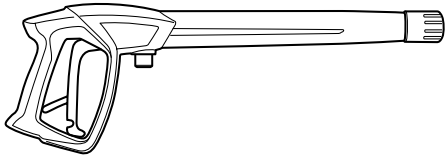

**Rotary scrubbing brush**  
Order No. 41.050 1

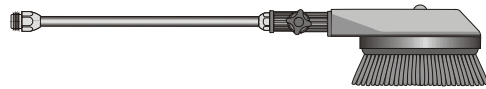

**Drain and pipe cleaning  
hose**  
10 m - Order No. 41.058.1  
15 m - Order No. 41.058

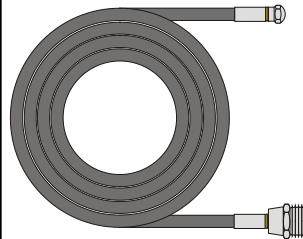

**Environmental, refuse disposal and water protection regulations must be observed when using the accessories!**

*... further combination possibilities*

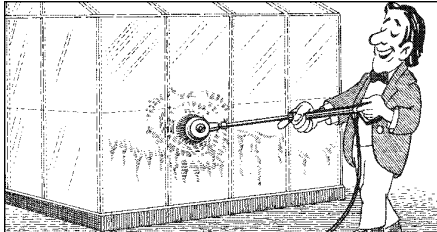

Car cleaning, glass, caravan, boat etc.: rotary washing brush with 40 cm extension and ST 30 nipple M22 x 1.5

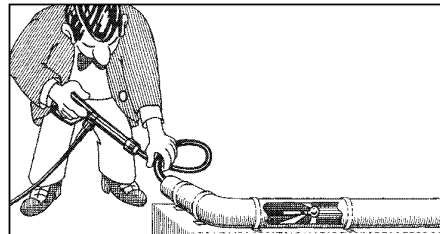

Cleaning pipes, channels and drains: pipe cleaning hose with KN nozzle and ST 30 nipple M22 x 1.5

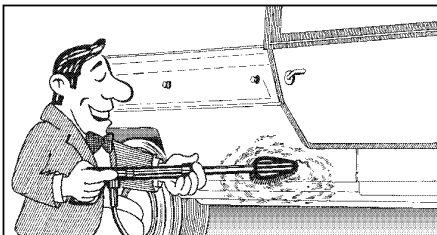

Cleaning cars and all smooth surfaces: brush with ST 30 nipple M22 x 1.5

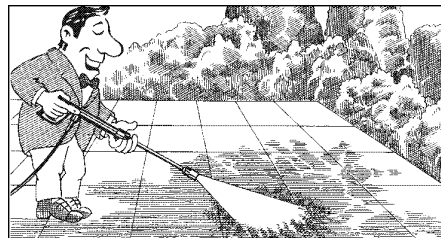

Rotary point sprayer for extreme soiling: Turbokiller with 40 cm extension and ST 30 nipple M22 x 1.5

## Small repairs

# The nozzle is blocked!

- No water but the gauge shows full pressure !

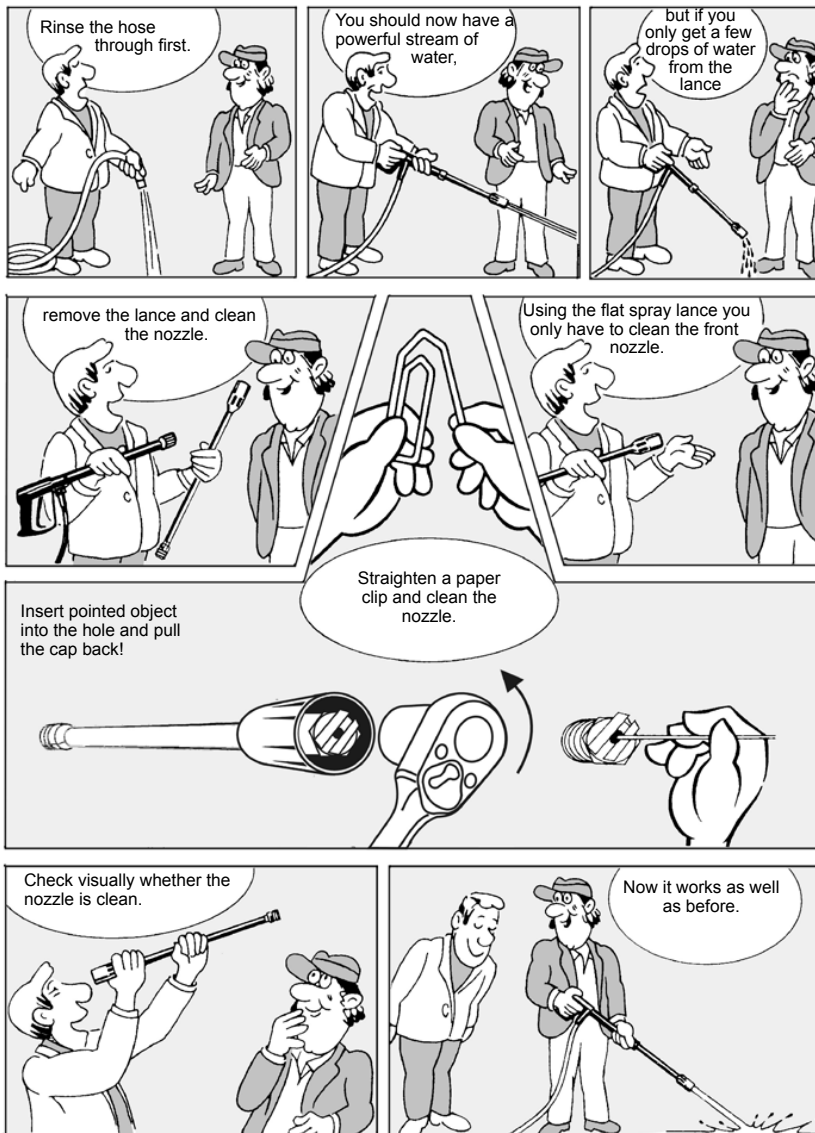



...do it yourself !

## Nozzle dirty or sticky!

- Pressure gauge does not show full pressure
- The high-pressure hose vibrates.
- Water comes out in spurts.
- If you do not use the high-pressure cleaner for some time the valves can stick.

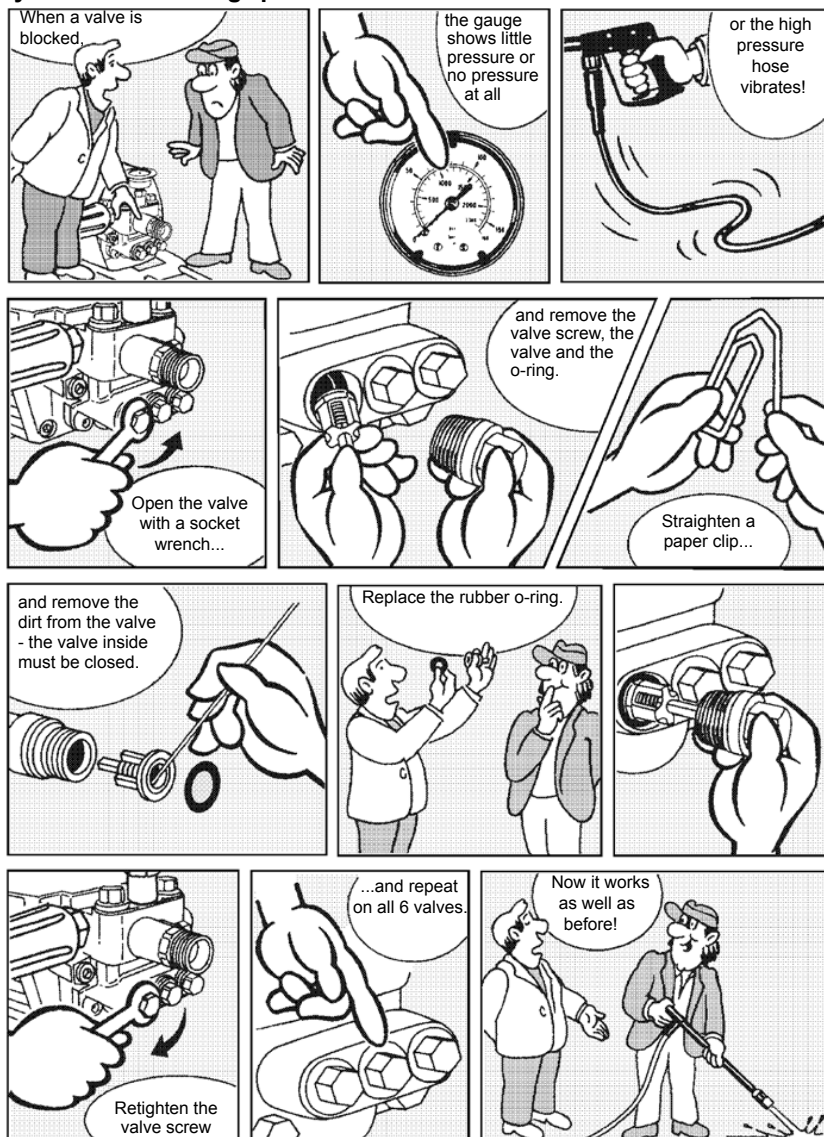

Complete Assembly

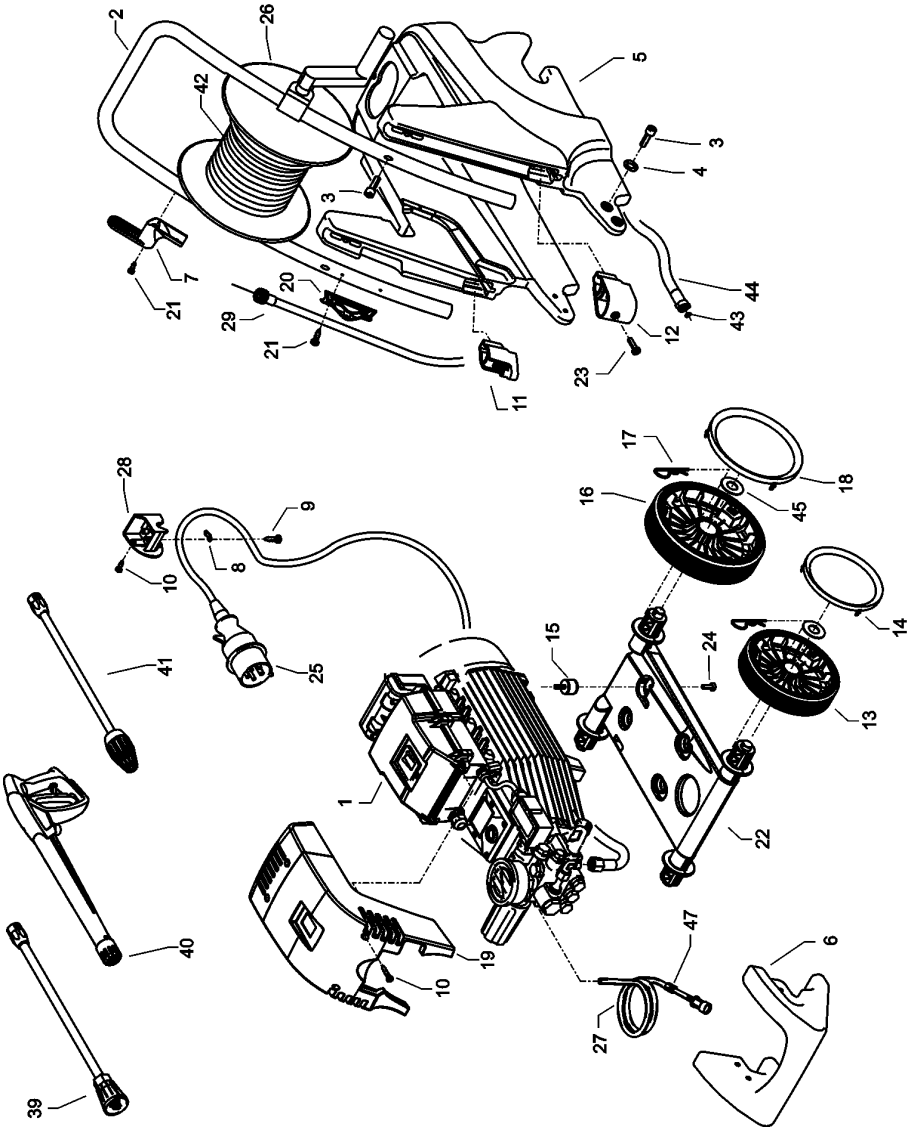

# quadro 9/170 - 12/150 TST

## Spare parts list KRÄNZLE quadro 9/170 - 11/140 - 12/150 TST Complete assembly

No	Description	Qty.	Ord.-No	No	Description	Qty.	Ord.-No
1.1	Motor-Pumpe ohne Elektrik für quadro 9/170 TST	1	46.582 1	23	Schraube M6x12	2	43.421
1.2	für quadro 11/140 TST	1	46.582 2	24	Schraube M6x12	4	44.090 1
1.3	für quadro 12/150 TST	1	46.582 3	25	Netzanschlusskabel 5,75m	1	41.092
1.4	Motor-Pumpe mit Elektrik für quadro 9/170 TST	1	46.583 1	25.1	Wechselstrom (quadro 9/170 - 11/140) Netzanschlusskabel 8m	1	44.036
1.5	für quadro 11/140 TST	1	46.583 2	26	Drehstrom (quadro 12/150) Schlauchtrommel kpl.	1	46.581
1.6	für quadro 12/150 TST	1	46.583 3	27	Chemiesaugschlauch (Gewebe) mit Filter	1	42.621
2	Schubbügel	1	46.504	28	Kabelführung mit Zugentlastung	1	46.506
3	Schraube M6x35 DIN6912	6	46.024	29	Verbindungsschlauch Schlauchtrommel	1	46.537
4	Scheibe 6,4 DIN125	4	50.189	39.1	Lanze mit Flachstrahldüse für 9/170 TST	1	12.393-M2003
5	Wasserkasten	1	46.510	39.2	Lanze mit Flachstrahldüse für 11/140 TST und 12/150 TST	1	12.393-M20045
6	Rammschutz vorn	1	46.511	40	Pistole M2000	1	12.480
7	Kabelaufwicklung	1	43.431	41.1	Schmutz-Killer 03 bei quadro 9/170 TST	1	41.570-03
8	Zugentlastung	1	43.431	41.2	Schmutz-Killer 045 bei quadro 11/140 TST und 12/150 TST	1	41.570-045
9	Kunststoffschraube 4,0 x 16	2	43.417	42	Hochdruckschlauch 15 m NW6	1	40.170
10	Kunststoffschraube 5,0 x 30	2	41.412	43	O-Ring 13 x 2,6	2	13.272
11	Lanzenständer	1	46.502	44	Verbindungsschlauch Wasserkasten	1	46.536
12	Köchertopf	1	46.503	45	Scheibe 40 x 19 x 1,5	4	46.533
13	Rad d210	2	44.538	47	Rückschlagventil für Chemiesaugschl.	1	44.240
14	Radkappe d210	2	46.011				
15	Gummipuffer 20 x 25	4	46.547				
16	Rad d250	2	46.508				
17	Federstecker	4	40.115 1				
18	Radkappe d250	2	46.509				
19.1	Frontplatte quadro 9/170 TST	1	46.535 1				
19.2	Frontplatte quadro 11/140 TST	1	46.535 2				
19.3	Frontplatte quadro 12/150 TST	1	46.535 3				
20	Lanzenhalter	2	42.610				
21	Blechschrabe 3,5x16 DIN7981	8	44.161				
22	Fahrgestell	1	46.501				

*Water inlet and brake*

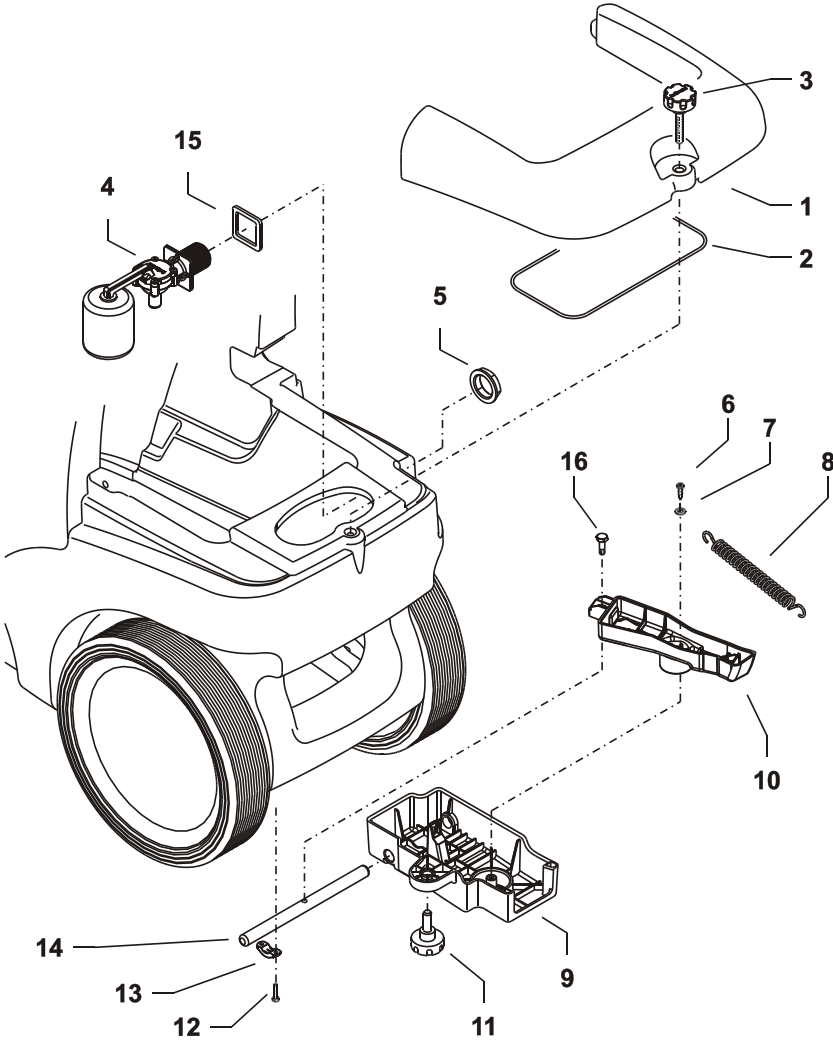

## *quadro 9/170 - 12/150 TST*

### **Spare parts list KRÄNZLE quadro 9/170 - 11/140 - 12/150 TST Water inlet and brake**

<b>No</b>	<b>Description</b>	<b>Qty.</b>	<b>Ord.-No</b>
1	Revisionsdeckel	1	46.512
2	Dichtung Revisionsdeckel	1	46.513
3	Sterngriffschraube M6	1	46.031
4	Schwimmerventil	1	46.250 1
5	Mutter R3/4"	1	46.258
6	Kunststoffschraube 5x14	1	43.426
7	Scheibe 5,3 DIN9021	1	50.152
8	Zugfeder	1	46.020
9	Deckel Bremse	1	46.016
10	Hebel Bremse	1	46.505
11	Sternschraube M8	1	50.168
12	Innensechskantschraube M4x10	4	46.002
13	Schelle	2	43.431
14	Bolzen für Bremse	1	46.018
15	Dichtung für Schwimmerventil	1	46.261
16	Bundschraube	1	46.019

# Pump motor

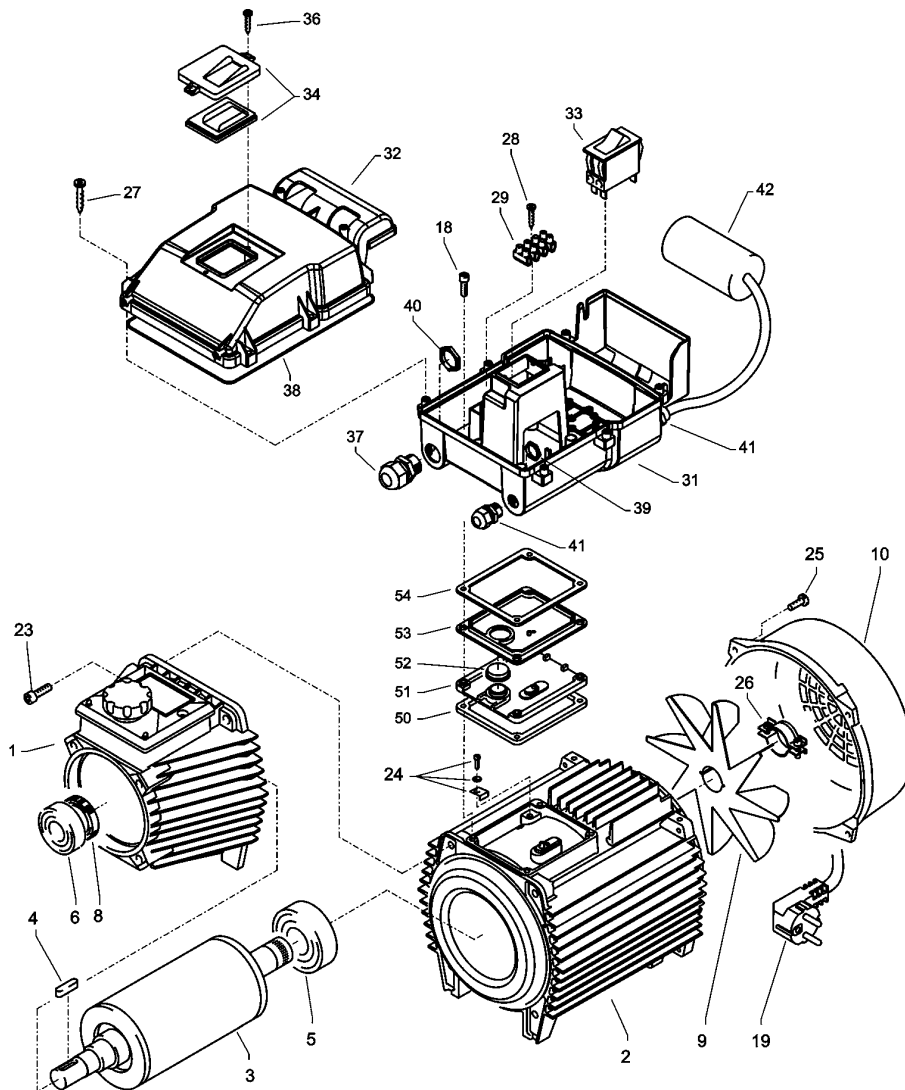

## *quadro 9/170 - 11/140 TST*

### **Spare parts list KRÄNZLE quadro 9/170 - 11/140 TST Pump motor**

<b>No</b>	<b>Description</b>	<b>Qty.</b>	<b>Ord.-No</b>
1	Ölgehäuse für AP mit Deckel und Dichtung	1	46.530 1
2	Motorgehäuse mit Stator Wechselstrom	1	46.528
3	Rotor mit Motorwelle	1	43.316
4	Passfeder 6 x 6 x 20	1	41.483 1
5	Motor-Lager B-Seite 6205 - 2Z	1	43.317
6	Motor-Lager Schulterlager 7304	1	41.027
8	Öldichtung 25 x 35 x 7	1	41.024
9	Lüfterrad BG 90	1	43.319
10	Lüfterhaube BG 90	1	43.320
18	Schraube M 4 x 22	4	41.489 1
19	Kabel mit Stecker	1	41.092
23	Innensechskantschraube M 6 x 30	4	43.037
24	Erdungsschraube kompl.	1	43.038
25	Schraube M 4 x 12	6	41.489
26	Schelle für Lüfterrad	1	43.454
27	Kunststoffschraube 5,0 x 25	6	41.414 1
28	Kunststoffschraube 3,5 x 20	2	43.415
29	Lüsterklemme 5-pol.	1	43.326 1
31	Schaltkasten Unterteil	1	46.012
32	Schaltkasten Deckel	1	46.013
33	Schalter 14,5 A Amazonas	1	41.111 6
34	Klemmrahmen mit Schalterabdichtung	1	43.453
36	Blechschrabe 3,5 x 14	2	44.525
37	PG 16-Verschraubung	1	41.419 1
38	Dichtung für Schaltkastendeckel	1	42.525
39	Gegenmutter für PG9-Verschraubung	2	41.087 1
40	Gegenmutter für PG16-Verschraubung	1	44.119
41	PG 9 - Verschraubung	1	42.541
42	Kondensator 70µF	1	43.322
43	PG 9 – Verschraubung reduziert	1	41.087
50	Gummidichtung für Schalterdistanzstück	1	41.111 3
51	Unterteil für Schalterdistanzstück	1	41.111 1
52	Runddichtung für Schalterdistanzstück	1	41.111 5
53	Oberteil für Schalterdistanzstück	1	41.111 2
54	Flachdichtung für Schalterdistanzstück	1	41.111 4
<b>Schaltkasten kpl. Pos. 22 - 54</b>			<b>46.585</b>
<b>Motor kpl. ohne Schalter Pos. 1 - 22</b>			<b>46.586</b>

## Pump motor

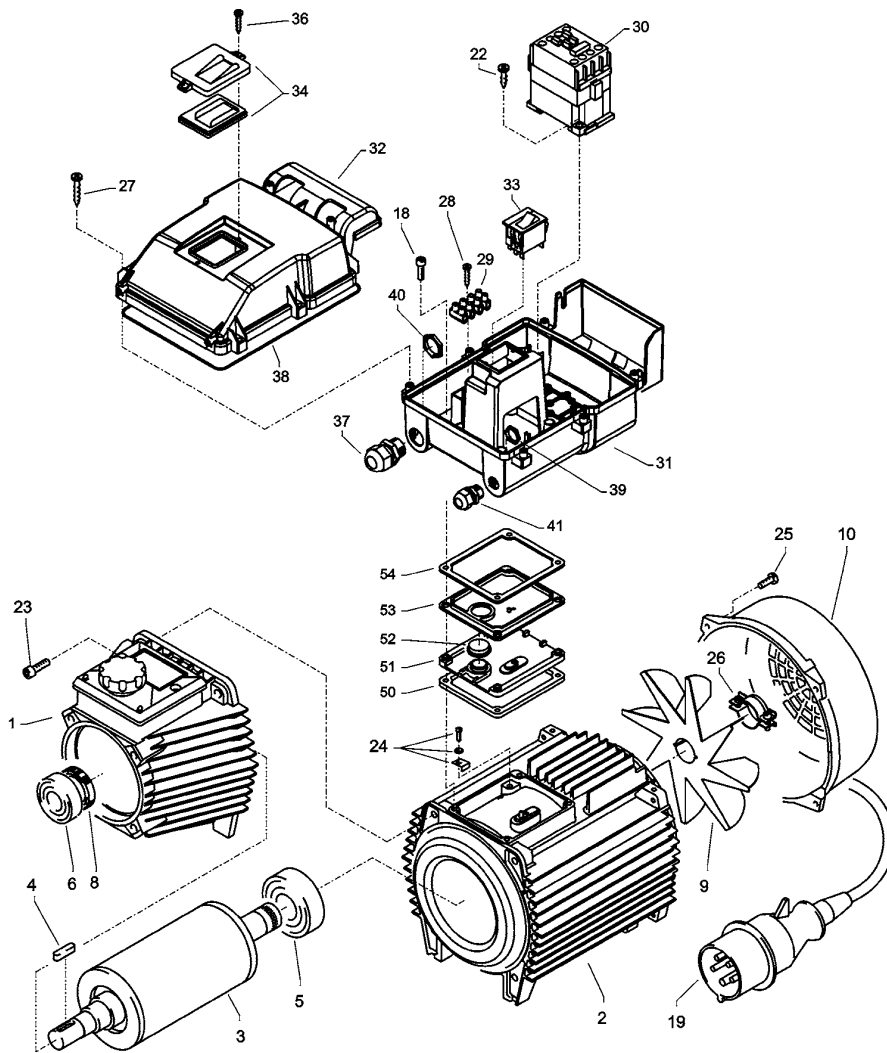



## *quadro 12/150 TST*

### **Spare parts list KRÄNZLE quadro 12/150 TST Pump motor**

<b>No</b>	<b>Description</b>	<b>Qty.</b>	<b>Ord.-No</b>
1	Ölgehäuse für AP	1	46.530 1
2	Motorgehäuse mit Stator Drehstrom	1	46.529
3	Rotor mit Motorwelle	1	43.316
4	Passfeder 6 x 6 x 20	1	41.483 1
5	Motor-Lager B-Seite 6205 - 2Z	1	43.317
6	Motor-Lager Schulterlager 7304	1	41.027
8	Öldichtung 25 x 35 x 7	1	41.024
9	Lüfterrad BG 90	1	43.319
10	Lüfterhaube BG 90	1	43.320
19	Kabel mit Stecker Drehstrom	1	44.036
22	Kunststoffschraube 4,0 x 16	2	43.417
23	Innensechskantschraube M 6 x 30	4	43.037
24	Erdungsschraube kpl.	1	43.038
25	Schraube M 4 x 12	6	41.489
26	Schelle für Lüfterrad	1	43.454
27	Kunststoffschraube 5,0 x 25	6	41.414 1
28	Kunststoffschraube 3,5 x 20	2	43.415
29	Lüsterklemme 5-pol.	1	43.326 1
30	Schütz 100-C12KN10 3x400V 50/60 Hz	1	46.005 1
31	Schaltkasten Unterteil	1	46.012
32	Schaltkasten Deckel	1	46.013
33	Schalter 8 A Amazonas	1	41.751
34	Klemmrahmen mit Schalterabdichtung	1	43.453
36	Blechschrabe 3,5 x 14	2	44.525
37	PG 16-Verschraubung	1	41.419 1
38	Dichtung für Schaltkastendeckel	1	42.525
39	Gegenmutter für PG9-Verschraubung	2	41.087 1
40	Gegenmutter für PG16-Verschraubung	1	44.119
41	PG 9 - Verschraubung	1	42.541
50	Gummidichtung für Schalterdistanzstück	1	41.111 3
51	Unterteil für Schalterdistanzstück	1	41.111 1
52	Runddichtung für Schalterdistanzstück	1	41.111 5
53	Oberteil für Schalterdistanzstück	1	41.111 2
54	Flachdichtung für Schalterdistanzstück	1	41.111 4

**Switch box compl.** items 22 - 54

**46.584**

**Motor compl. without switch** items 1 - 2246.587

# Pump

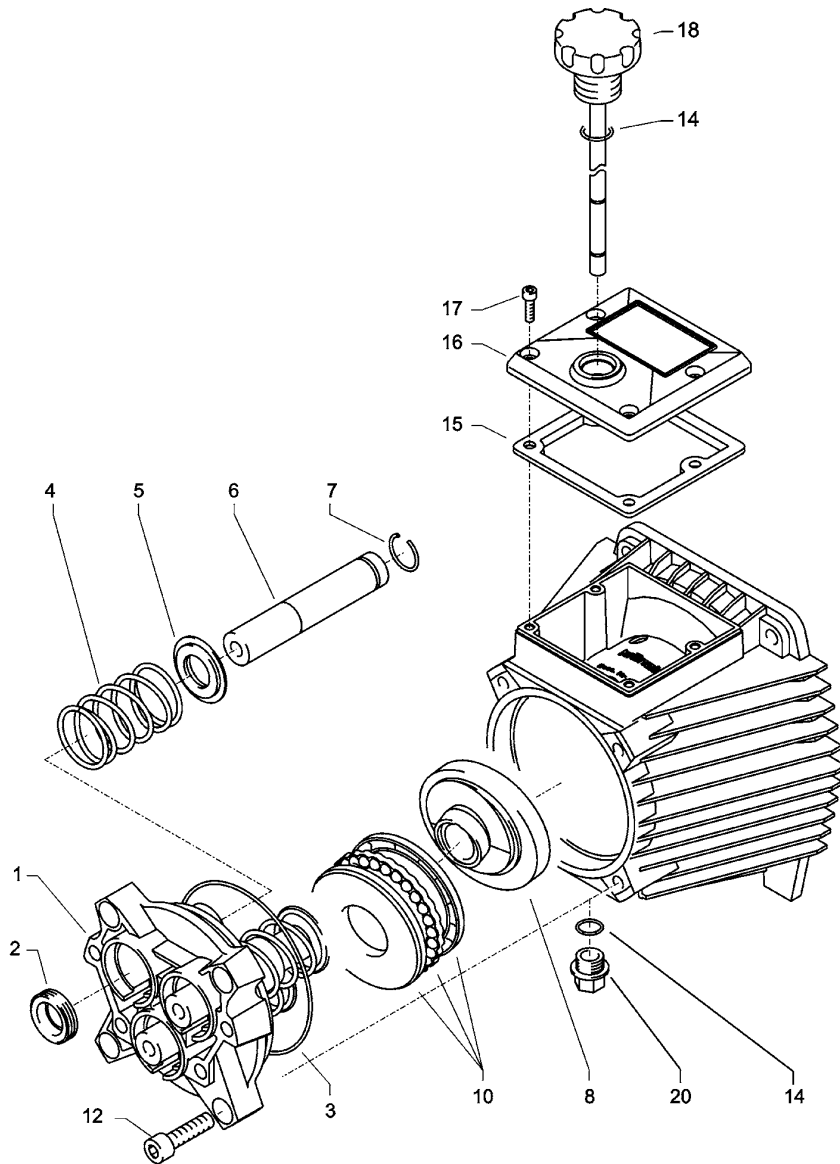

## quadro 9/170 TST

### Spare parts list KRÄNZLE 9/170 TS T Pump with plunger, diameter 15 mm

No	Description	Qty.	Ord.-No
1	Gehäuseplatte für 15 mm Plunger	1	42.906
2	Öldichtung 15 x 24 x 7	3	42.907
3	O-Ring Viton 88 x 2	1	41.021 1
4	Plungerfeder	3	41.033
5	Federdruckscheibe 15 mm	3	42.909
6	Plunger 15 mm	3	42.908
7	Sprengring 15 mm	3	42.910
8	Taumelscheibe 14,3°	1	41.028-14,3
10	Axial-Rillenkugellager 3-teilig	1	43.486
12	Innensechskantschraube M 8 x 30	4	41.036 1
14	O-Ring 14 x 2	2	43.445
15	Dichtung für Deckel	1	46.531
16	Deckel für Ölgehäuse	1	46.532
17	Schraube M5x12	4	41.019 4
18	Ölmesstab AP	1	46.546
20	Ölablassstopfen M18x1,5 mit Magnet	1	48.020
<b>AP pump complete with 15mm plungers</b> for quadro 9/170 consisting of: items 1-18			<b>46.588-14,5</b>

# Pump

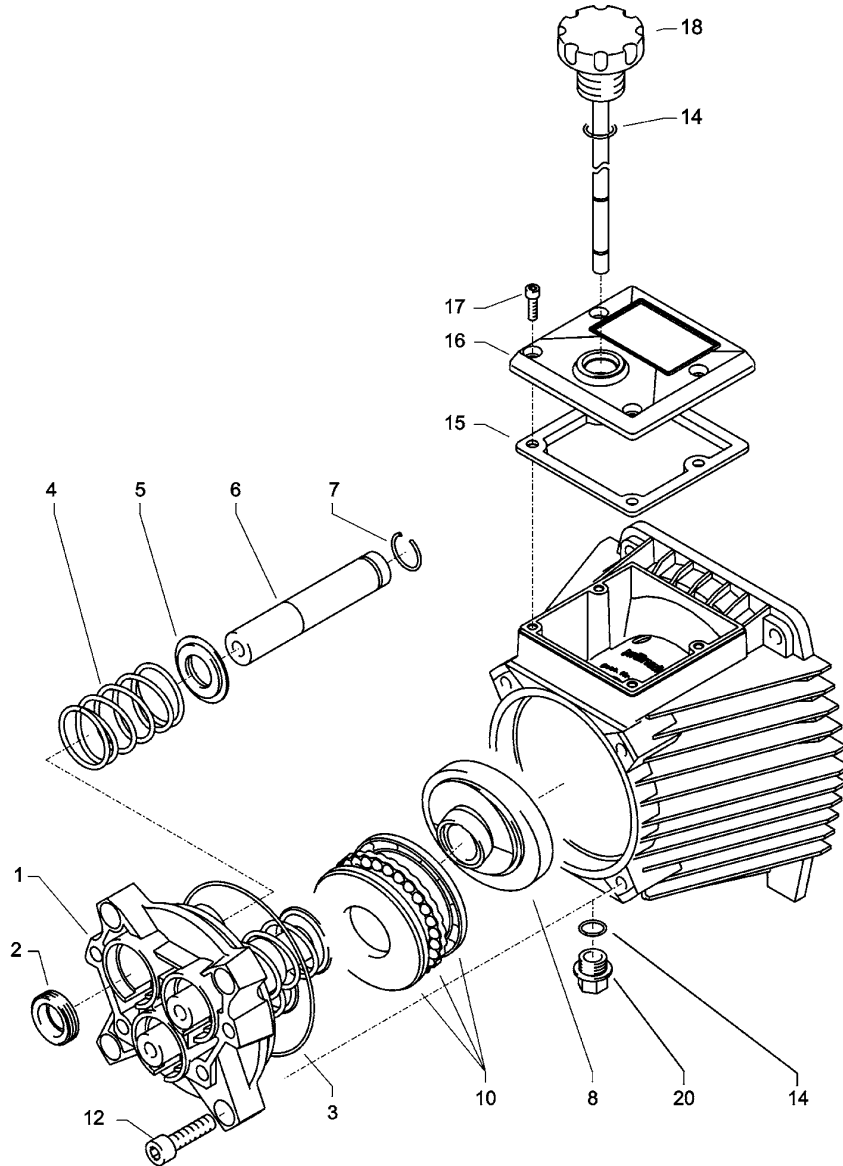

## quadro 11/140 - 12/150 TST

### Ersatzteilliste KRÄNZLE 11/140 - 12/150 TS T Pump with plunger, diameter 18 mm

No	Description	Qty.	Ord.-No
1	Gehäuseplatte für 18 mm Plunger	1	41.020 2
2	Öldichtung 18 x 28 x 7	3	41.031
3	O-Ring Viton 88 x 2	1	41.021 1
4	Plungerfeder	3	41.033
5	Federdruckscheibe 18 mm	3	41.034
6	Plunger 18 mm	3	41.032 1
7	Sprengring 18 mm	3	41.035
8	Taumelscheibe 12,5° (quadro 11/140 TST)	1	41.028-12,5
8.1	Taumelscheibe 13,75° (quadro 12/150 TST)	1	41.028-13,75
10	Axial-Rillenkugellager 3-teilig	1	43.486
12	Innensechskantschraube M 8 x 30	4	41.036 1
14	O-Ring 14 x 2	2	43.445
15	Dichtung für Deckel	1	46.531
16	Deckel für Ölgehäuse	1	46.532
17	Schraube M5x12	4	41.019 4
18	Ölmesstab AP	1	46.546
20	Ölablassstopfen M18x1,5 mit Magnet	1	48.020

**AP pump complete with 18mm plungers**

for quadro 11/140

consisting of: items 1-18

**46.589-12,5**

**AP pump complete with 18mm plungers**

for quadro 12/150

consisting of: items 1-18

**46.589-13,5**

## Unloader valve and pressure switch

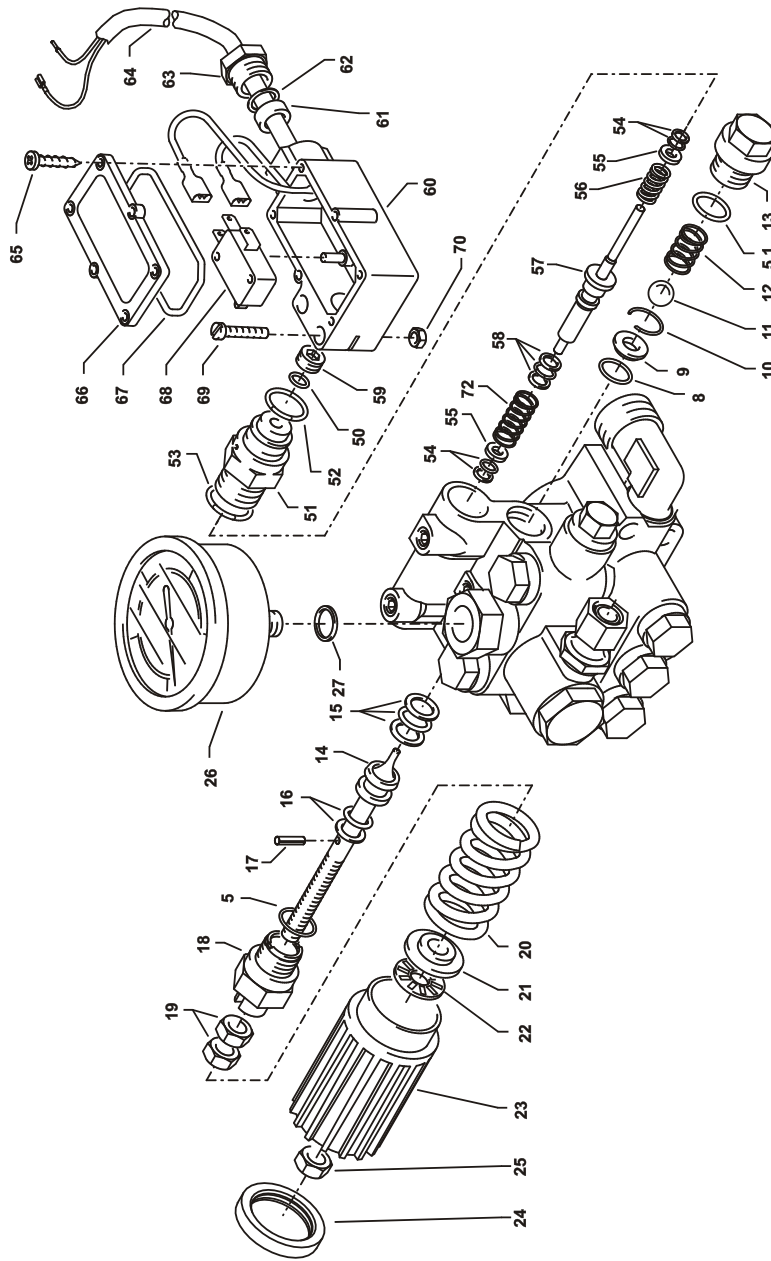

## quadro 9/170 - 12/150 TST

### Spare parts list KRÄNZLE quadro 9/170 - 12/150 TST Unloader valve and pressure switch

No	Description	Qty.	Ord.-No	No	Description	Qty.	Ord.-No
5	O-Ring 16 x 2	1	13.150	50	O-Ring 3,3 x 2,4	1	12.136
5.1	O-Ring 13,94 x 2,62	1	42.167	51	Führungsteil Steuerstößel	1	15.009 1
8	O-Ring	1	12.256	52	O-Ring 13 x 2,6	1	15.017
9	Edelstahlsitz	1	14.118	53	O-Ring 14 x 2	1	43.445
10	Sicherungsring	1	13.147	54	Parbaks 4 mm	2	12.136 2
11	Edelstahlkugel 8,5 mm	1	13.148	55	Stützscheibe	2	15.015 1
12	Edelstahlfeder	1	14.119	56	Edelstahlfeder	1	15.016
13	Verschlusschraube	1	14.113	57	Steuerstößel lang	1	15.010 2
14	Steuerkolben	1	14.134	58	Parbaks 7 mm	1	15.013
15	Parbaks 16 mm	1	13.159	59	Stopfen M10x1 (durchgebohrt)	1	13.385 1
16	Parbaks 8 mm	1	14.123	60	Gehäuse Elektroschalter	1	15.007
17	Spannstift	1	14.148	61	Gummimanschette PG 9	1	15.020
18	Kolbenführung spezial	1	42.105	62	Scheibe PG 9	1	15.021
19	Mutter M 8 x 1	2	14.144	63	Verschraubung PG 9	1	15.022
20	Ventilfeder schwarz	1	14.125	64	Kabel 2 x 1,5 mm <sup>2</sup> für quadro 9/170 - 11/140 TS	1	46.515
21	Federdruckscheibe	1	14.126	64.1	Kabel 2 x 1,0 mm <sup>2</sup> für quadro 12/150 TS	1	46.516
22	Nadellager	1	14.146	65	Blechschaube 2,8 x 16	6	15.024
23	Handrad	1	40.457	66	Deckel Elektroschalter	1	15.008
24	Kappe Handrad	1	40.458	67	O-Ring 44 x 2,5	1	15.023
25	Elastic-Stop-Mutter	1	14.152	68	Mikroschalter	1	15.018
26	Manometer 0-250 bar	1	15.039	69	Zylinderschraube M 4 x 20	2	15.025
27	Aluminium - Dichtring	2	13.275	70	Sechskant-Mutter M 4	2	15.026
				72	Druckfeder 1 x 8,6 x 30	1	40.520

**Rep.-kit Pressure switch mech.**  
 consisting of: 1x items 51; 1x items 52;  
 1x items 53; 3x items 54; 1x items 55; 1x items 56;  
 1x items 57; 1x items 58; 1x items 59

**Guide piston compl. w. hand wheel**      **40.490**  
 items 5, 14-25

## Valve housing

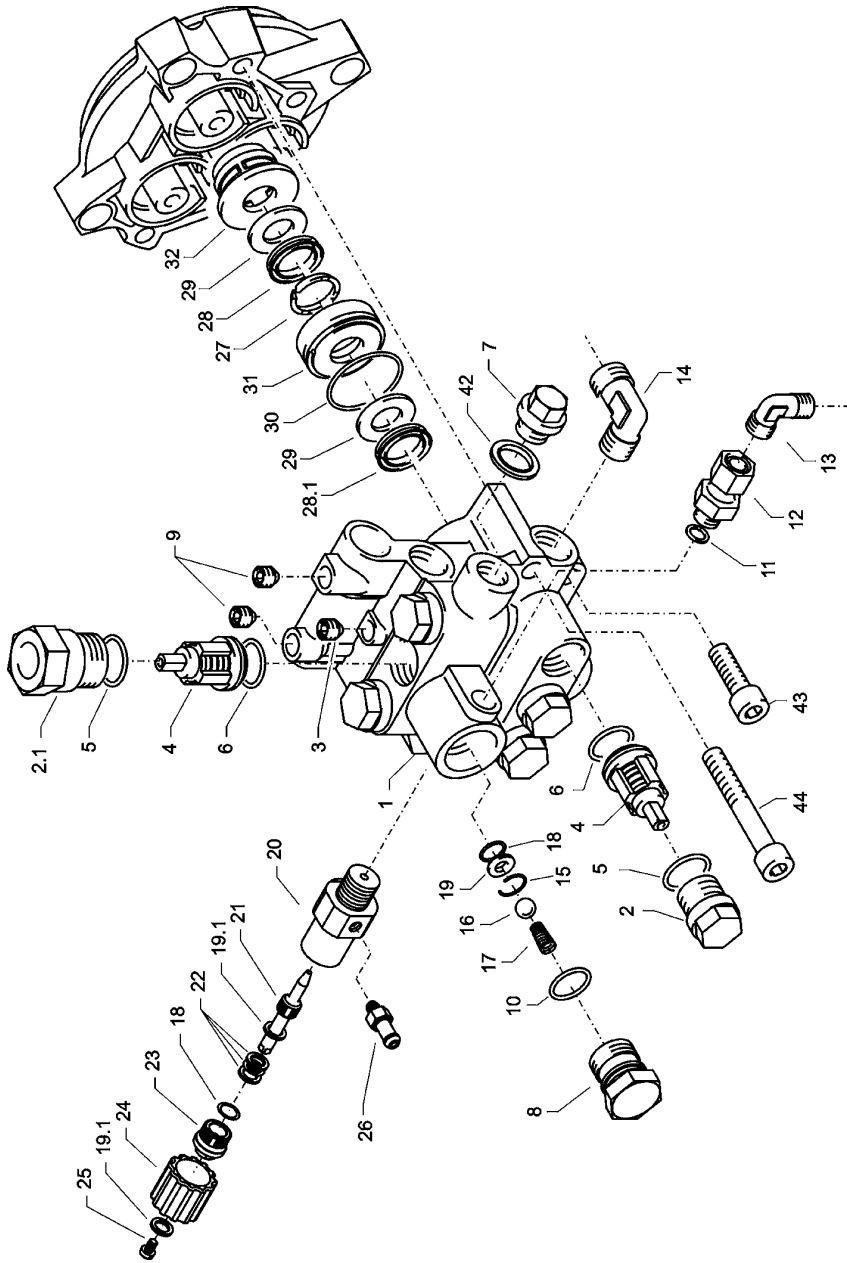



# KRÄNZLE 9/170 TS T

## Spare parts list KRÄNZLE 9/170 TS T Valve housing APG for plunger diameter 15 mm

No	Description	Qty.	Ord.-No	No	Description	Qty.	Ord.-No
1	Ventilgehäuse	1	42.163 3	27	Stützring rot 15mm	3	42.913
2	Ventilstopfen	5	41.714	28	Manschette weich 15mm	3	42.902
2.1	Ventilstopfen mit R1/4" IG	1	42.026 1	28.1	Manschette Gewebe 15mm	3	42.902 1
3	Dichtstopfen M 10 x 1	1	43.043	29	Backing 15 x 24	6	42.903
4	Ventile (grün) für APG-Pumpe	6	41.715 1	30	O-Ring 28,3 x 1,78	3	40.026
5	O-Ring 16 x 2	6	13.150	31	Leckagering 15 mm	3	42.905
6	O-Ring 15 x 2	6	41.716	32	Zwischenring 15 mm	3	42.904 1
7	Dichtstopfen R1/4" mit Bund	1	42.103	42	Kupferring	1	42.104
8	Ausgangsteil	1	40.522	43	Innensechskantschraube M 8 x 30	2	41.036 1
9	Dichtstopfen M 8 x 1	2	13.158	44	Innensechskantschraube M 8 x 55	2	41.017 1
10	O-Ring 18 x 2	1	43.446	<b>Rep.-kit valves for APG-pump</b> consisting of: 6x items 4; 6x items 5; 6x items 6			
11	Aluminium - Dichttring	3	13.275	<b>Repair kit for sleeves 15 mm</b> consisting of 3x items 27; 3x items 28; 3x items 28.1; 6x items 29; 3x items 30			
12	Ausgangsteil Pumpe R1/4" x 12	1	46.039	<b>Valve housing compl. 15 mm</b> with integr. ULH and pressure switch			
13	Ermeto-Winkel 12 L x 12 L	1	42.630	<b>Chemical valve compl.</b> consisting of: 1x items 20-26			
14	Ermetowinkel R3/8" x 12L	1	44.092				
15	Sprengtring	1	13.147				
15	Edelstahlkugel Ø10	1	12.122				
17	Rückschlagfeder „K“	1	14.120 1				
18	O-Ring 11 x 1,5	2	12.256				
19.1	Edelstahlsitz Ø 7	1	14.118				
20	Scheibe 6 mm	2	43.045				
21	Grundteil Eckventil	1	46.600				
21	Ventilnadel	1	46.601				
22	Parbaks 6 mm	1	46.606				
23	Führungsteil	1	46.602				
24	Handrad	1	46.603				
25	Schraube M4x8 Messing	1	46.604				
26	Saugzapfen M10x1	1	13.236				

# Valve housing

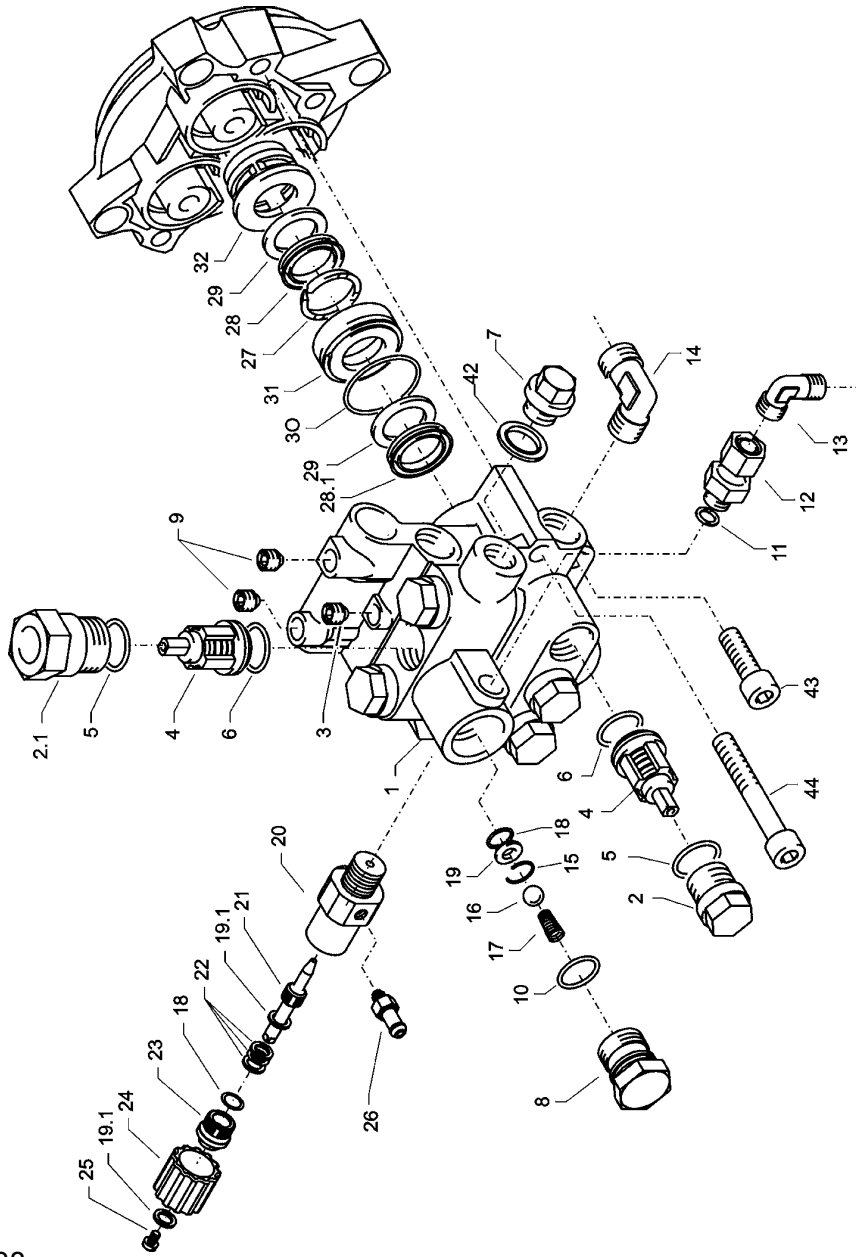

## quadro 11/140 - 12/150 TST

### Spare parts list KRÄNZLE 11/140 - 12/150 TS T Valve housing APG for plunger diameter 18 mm

No	Description	Qty.	Ord.-No	No	Description	Qty.	Ord.-No
1	Ventilgehäuse	1	42.160 3	27	Druckring 18mm	3	41.018
2	Ventilstopfen	5	41.714	28	Manschette 18 x 26 x 4/2	3	41.013
2.1	Ventilstopfen mit R1/4" IG	1	42.102	28.1	Gewebemanschette 18 x 26 x 4/2	3	41.013 1
3	Dichtstopfen M 10 x 1	1	43.043	29	Backring 18 x 26	6	41.014
4	Ventile (grün) für APG-Pumpe	6	41.715 1	30	O-Ring 28,3 x 1,78	3	40.026
5	O-Ring 16 x 2	6	13.150	31	Leckagering 18 mm	3	41.066
6	O-Ring 15 x 2	6	41.716	32	Zwischenring 18 mm	3	41.015 2
7	Dichtstopfen R1/4" mit Bund	1	42.103	42	Kupferring	1	42.104
8	Ausgangsteil	1	40.522	43	Innensechskantschraube M 8 x 30	2	41.036 1
9	Dichtstopfen M 8 x 1	2	13.158	44	Innensechskantschraube M 8 x 55	2	41.017 1
10	O-Ring 18 x 2	1	43.446		<b>Rep.-Satz Ventile für APG-Pumpe</b>		<b>41.748 1</b>
11	Aluminium - Dichtring	3	13.275		bestehend aus je 6x Pos. 4; 6x Pos. 5; 6x Pos. 6		
12	Ausgangsteil Pumpe R1/4" x 12	1	46.039		<b>Rep.-Satz Manschetten 18 mm</b>		<b>41.049 1</b>
13	Ermeto-Winkel 12 L x 12 L	1	42.630		bestehend aus je 3x Pos. 27; 3x Pos. 28;		
14	Ermetowinkel R3/8" x 12L	1	44.092		3x Pos. 28.1; 6x Pos. 29; 3x Pos. 30		
15	Sprengring	1	13.147		<b>Ventilgehäuse kpl.</b> mit integr. ULH und		<b>46.591</b>
16	Edelstahlkugel Ø10	1	12.122		Druckschalter		
17	Rückschlagfeder „K“	1	14.120 1		<b>Chemieventil kpl.</b>		<b>46.610</b>
18	O-Ring 11 x 1,5	2	12.256		bestehend aus je 1x Pos. 18-26		
19.1	Edelstahlsitz Ø 7	1	14.118				
20	Scheibe 6 mm	2	43.045				
21	Grundteil Eckventil	1	46.600				
22	Ventilnadel	1	46.601				
23	Parbaks 6 mm	1	46.606				
24	Führungsteil	1	46.602				
25	Handrad	1	46.603				
26	Schraube M4x8 Messing	1	46.604				
	Saugzapfen M10x1	1	13.236				

# Hose drum

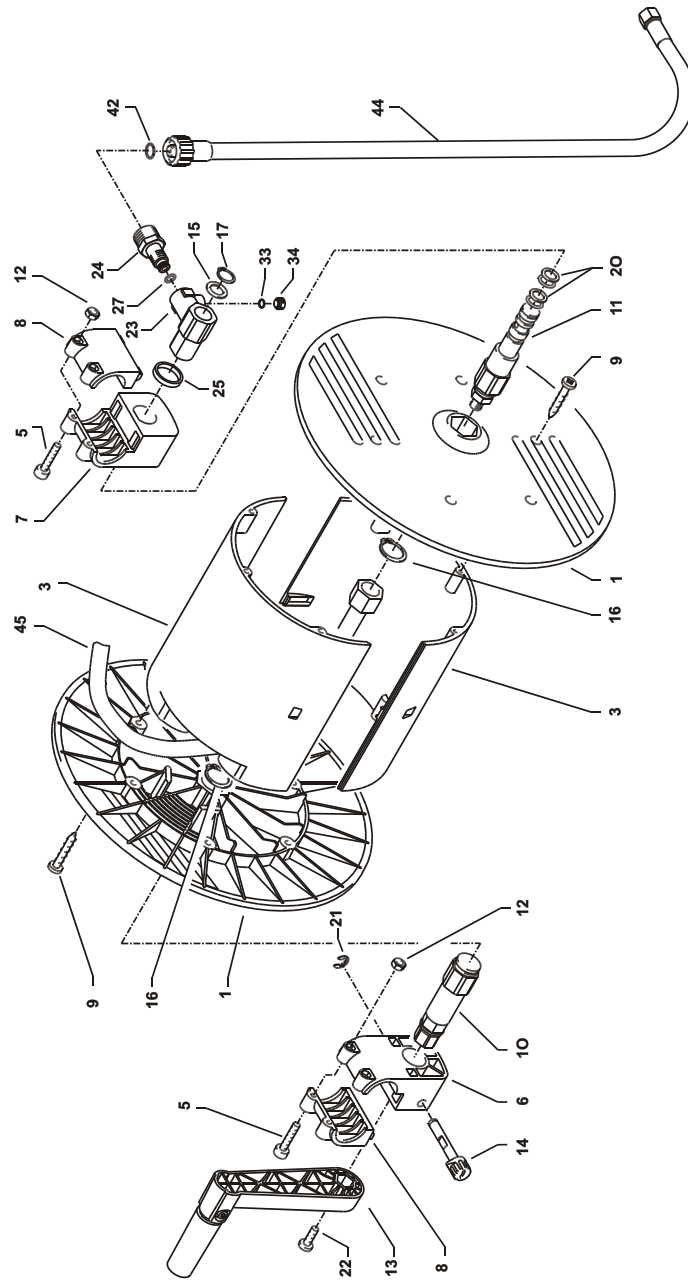

## quadro 9/170 - 12/150 TST

### Spare parts list KRÄNZLE quadro 9/170 - 11/140 - 12/150 TST Hose drum

No	Description	Qty.	Ord.-No	No	Description	Qty.	Ord.-No
1	Seitenschale	2	46.201	23	Drehgelenk	1	40.167
3	Trommelteil	2	46.202	24	Anschlussstück	1	40.308 1
5	Innensechskantschraube M 4 x 25	4	40.313	25	Distanzring	1	40.316
6	Lagerklotz mit Bremse	1	40.306 1	27	O-Ring 6,86 x 1,78	1	40.585
7	Lagerklotz links	1	40.305 1	33	O-Ring 6 x 1,5	1	13.386
8	Klemmstück	2	40.307 1	34	Stopfen M 10 x 1	1	13.385
9	Kunststoffschraube 5,0 x 20	12	43.018	42	O-Ring 13 x 2,6	2	13.272
10	Antriebswelle	1	46.204	44	Verbindungsschlauch Schlauchtrommel	1	46.537
11	Welle Wasserführung	1	46.203 1	45	Hochdruckschlauch 15 m NW6	1	40.170
12	Elastic-Stop-Mutter M 4	4	40.111		<b>Hose drum</b> compl. without hose		<b>46.581</b>
13	Handkurbel	1	40.320 0		consisting of items 1 - 34		
14	Verriegelungsbolzen	1	40.312				
15	Scheibe MS 16 x 24 x 2	1	40.181				
16	Wellensicherungsring 22 mm	2	40.117				
17	Wellensicherungsring 16 mm	1	40.182				
20	Paarbaks 16 mm	2	13.159				
21	Sicherungsscheibe 6 DIN6799	1	40.315				
22	Schraube M 5 x 10	1	43.021				

## Gun and lance

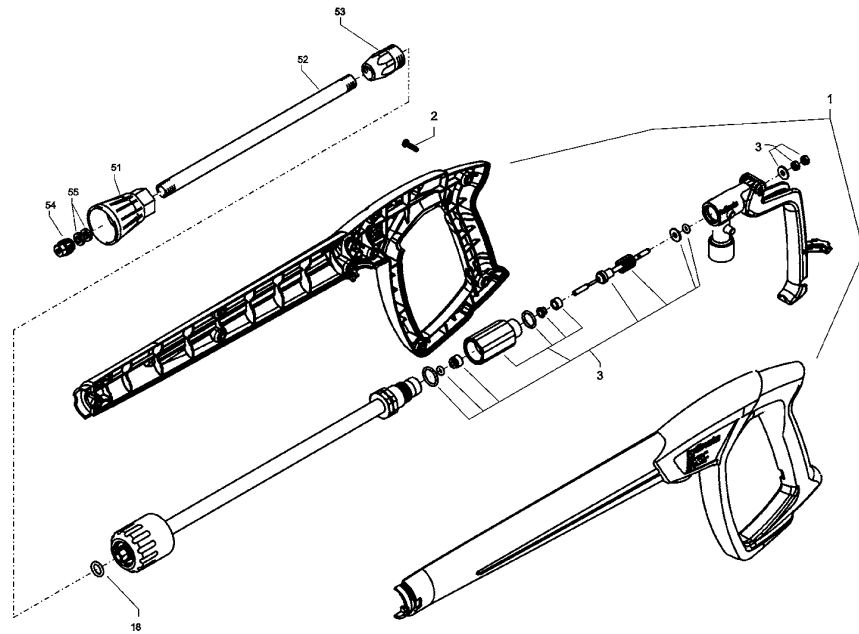

No	Description	Qty.	Ord.-No
1	Pistolenschale re+li	1	12.450
2	Schraube 3,5 x 14	10	44.525
3	Reparatursatz M2000		12.454
18	O-Ring 9,3 x 2,4	1	13.273
51	Düsenschutz	1	26.002 1
52	Rohr 500 mm; bds. M12x1	1	41.527 1
53	ST 30 Nippel M 22 x 1,5 / M12x1 m. ISK	1	13.363
54	Flachstrahldüse 2003 (quadro 9/170)	1	M2003
54.1	Flachstrahldüse 20045 (quadro 11/140; quadro 12/150)	1	M20045
55	Aluminium-Dichtring 8,3x11,3x2	2	13.275 1

**Lanze kpl. mit HD-Düse 20030**  
**Lanze kpl. mit HD-Düse 20045**

**12.392 5-M20030**  
**12.392 5-M20045**

## Dirtkiller

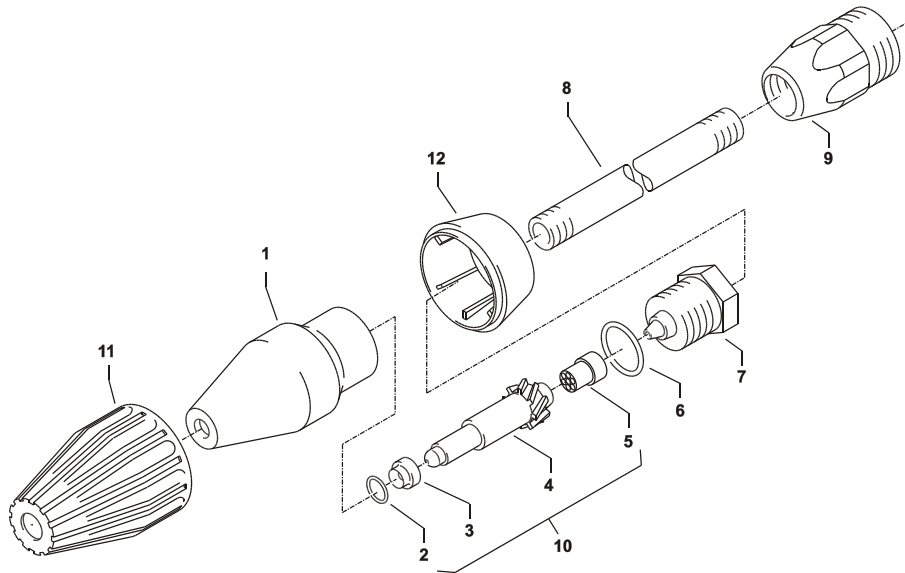

### Spare parts list KRÄNZLE quadro 9/170 - 12/150 TST Dirtkiller

No	Description	Qty.	Ord.-No
1	Sprühkörper	1	41.520
2	O-Ring 6,88 x 1,68	1	41.521
3	Düsensitz	1	41.522
4	Nozzle 03 (quadro 9/170)	1	41.523 4
4.1	Nozzle 045 (quadro 11/140, 12/150)	1	41.523
5	Stabilisator	1	41.524
6	O-Ring	1	40.016 1
7	Sprühstopfen M12x1 IG	1	41.526
8	Rohr 400 mm lang; bds. M12x1	1	15.002
9	ST 30 Nippel M 22 x 1,5 / R1/4" m. ISK	1	13.363
11	Front cap for Dirtkiller	1	41.528 1
12	Rear cap for Dirtkiller 03	1	41.542 1
12.1	Rear cap for Dirtkiller 045	1	41.540 2

**Rep.-kit Dirtkiller 03**

**41.096 1**

**Rep.-kit Dirtkiller 045**

**41.097**

consisting of: 1x 2; 3; 4; 5

**Dirtkiller 03** with lance 400mm

**41.073 8**

**Dirtkiller 045** with lance 400mm

**41.072 5**

## Wiring diagram

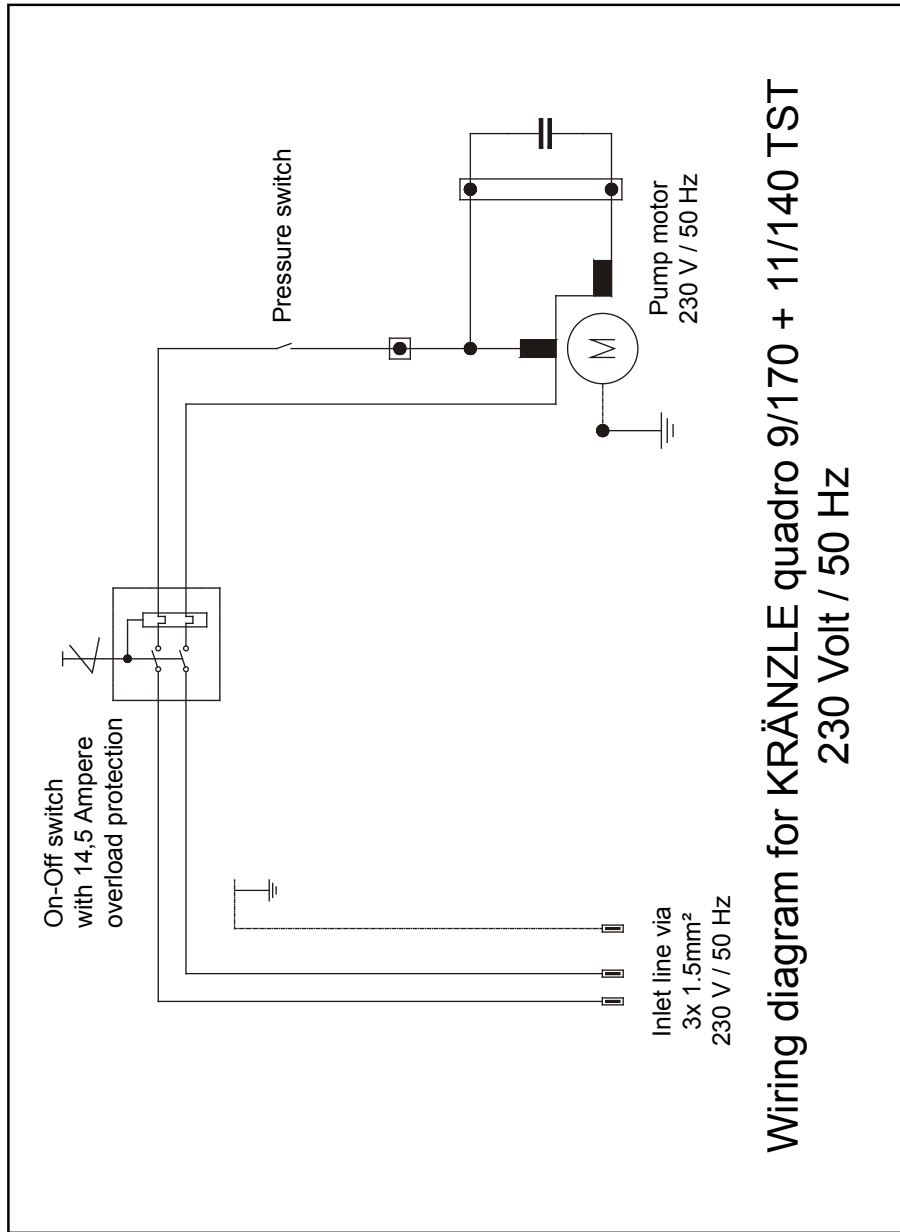



Wiring diagram

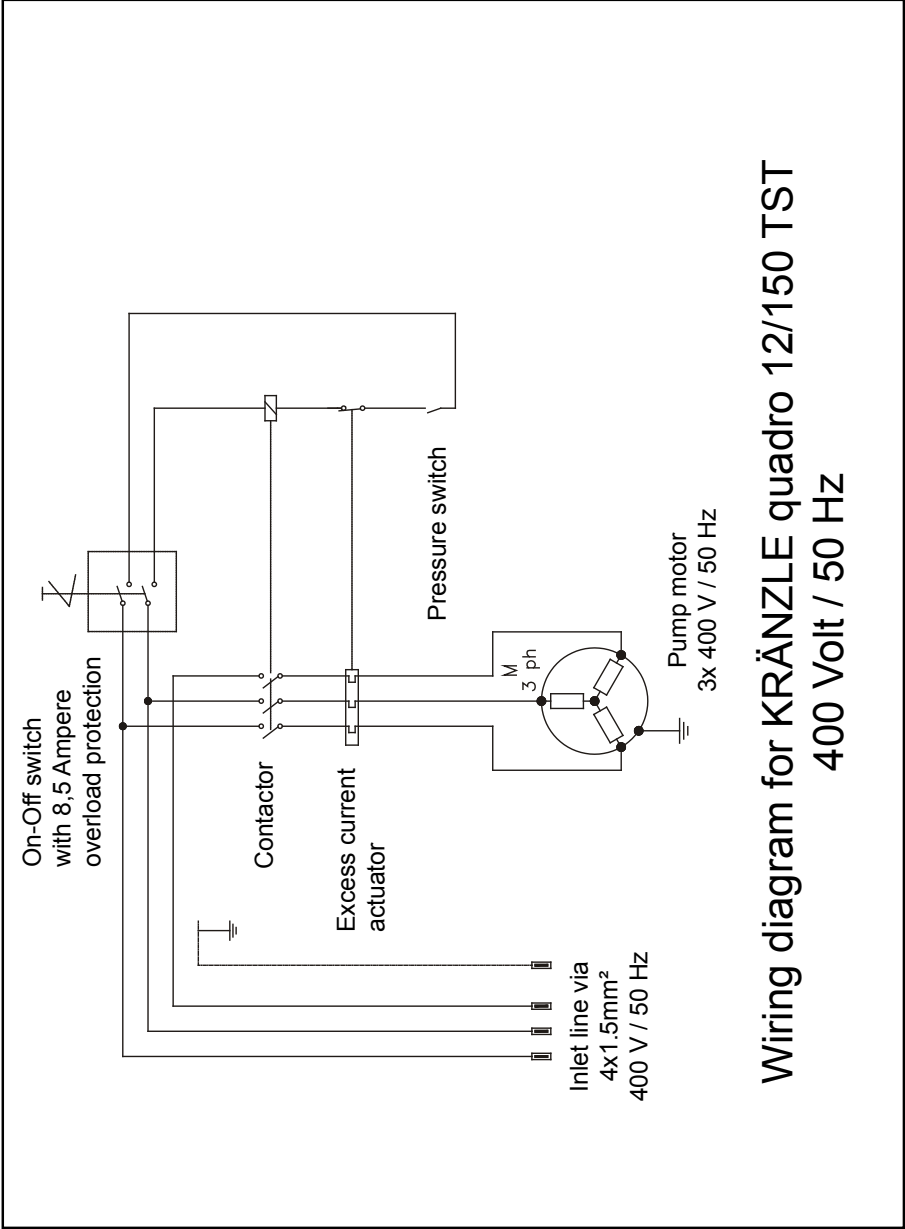

## General rules

### Inspections

The machine must be inspected according to the “Guidelines for Liquid Spray Devices” at least once every 12 months by a qualified person, to ensure that continued safe operation is guaranteed.

The results of the inspection are to be recorded in writing. (see pages 48-49)

### Accident prevention

The machine is designed for accidents to be impossible if used correctly.

The operator is to be notified of the risk of injury from hot machine parts and the high pressure water jet. The “Guidelines for Liquid Spray Devices” must be complied with. (see pages 16 - 17).

**Check the oil level at the oil dip stick prior to each use (see also page 11).  
(Ensure horizontal position!)**

#### Oil change:

The first oil change should be carried out after approximately 50 operating hours, then every year or after 1000 operating hours. If the oil turns grey or white, you must change the oil of your high pressure pump in any case.

Place the device over a collection reservoir and open the oil discharge screw at the bottom.

Ensure a horizontal position to drain the oil completely. The oil is to be caught in the reservoir and disposed of in an approved manner.

New oil: 0,4 l

Motor oil: Castrol 10 W-60 SAE halfsynthetic oil



Oil discharge screw



## *Inspection report for HP cleaners*

HP cleaners for industrial use have to be checked by an expert every 12 months!  
 Inspection report on annually carried out Labour Safety Inspection (UUV) according to the Guidelines for Liquid Spray Equipment. (This inspection sheet serves as proof for the completion of the retest and must be kept carefully!) Kränzle test seals: Order no. UUV200106

Owner: ..... Type:.....  
 Address: ..... Serial no.: .....  
 ..... Rep. order no.: .....

Scope of inspection	o.k.	yes	no	repaired
Type plate (on hand)				
Operating manual (on hand)				
Protective covering, -device				
Pressure line (tightness)				
Pressure gauge (function)				
Float valve (tightness)				
Spraying device (marking)				
HP-hose / connector (damage, marking)				
Safety valve opens at 10 % / 20 % exceeding of operating pr.				
Power cable (damage)				
Protective conductor (connected)				
On / Off switch				
Used chemicals				
Allowed chemicals				

Inspection data	determined value	set value
High-prsure nozzle		
Operating pressure.....bar		
Switch off pressure.....bar		
Conductor reist. not exceeded / value		
Insulation		
Leakage current		
Gun locked		

**Inspection result (tick)**

- The appliance was checked by an expert according to the Guidelines for Liquid Spray Equipment, the defects found have been rectified so that the Labour Safety can be confirmed.
- The appliance was checked by an expert according to the Guidelines for Liquid Spray Equipment. The Labour Safety cannot be confirmed unless the defects found are rectified by repair or replacement of the faulty parts

The next retest according to the Guidelines for Liquid Spray Equipment has to be carried out by:

Month.....Year .....

Place, date.....Signature .....

## Inspection report for HP cleaners

HP cleaners for industrial use have to be checked by an expert every 12 months!  
 Inspection report on annually carried out Labour Safety Inspection (UVV) according to the Guidelines for Liquid Spray Equipment. (This inspection sheet serves as proof for the completion of the retest and must be kept carefully!) Kränzle test seals: Order no. UVV200106

Owner: ..... Type:.....  
 Address: ..... Serial no.: .....  
 ..... Rep. order no.: .....

Scope of inspection	o.k.	yes	no	repaired
Type plate (on hand)				
Operating manual (on hand)				
Protective covering, -device				
Pressure line (tightness)				
Pressure gauge (function)				
Float valve (tightness)				
Spraying device (marking)				
HP-hose / connector (damage, marking)				
Safety valve opens at 10 % / 20 % exceeding of operating pr.				
Power cable (damage)				
Protective conductor (connected)				
On / Off switch				
Used chemicals				
Allowed chemicals				

Inspection data	determined value	set value
High-prsure nozzle		
Operating pressure.....bar		
Switch off pressure.....bar		
Conductor reist. not exceeded / value		
Insulation		
Leakage current		
Gun locked		

**Inspection result (tick)**

- The appliance was checked by an expert according to the Guidelines for Liquid Spray Equipment, the defects found have been rectified so that the Labour Safety can be confirmed.
- The appliance was checked by an expert according to the Guidelines for Liquid Spray Equipment. The Labour Safety cannot be confirmed unless the defects found are rectified by repair or replacement of the faulty parts

The next retest according to the Guidelines for Liquid Spray Equipment has to be carried out by:

Month.....Year .....

Place, date.....Signature .....

## Warranty

### **Guarantee**

The guarantee is only valid for material and manufacturing errors. Wearing does not fall within this guarantee.

The instructions in our operating manual must be complied with. The operating instructions form part of the guarantee. The Guarantee is void if other parts are used than genuine Kränzle accessory parts or genuine Kränzle spare parts.

For high-pressure cleaners sold to the user the guarantee period is 24 month.

For high-pressure cleaners sold for industrial use the guarantee period is 12 month. In the case of a guarantee please contact your dealer or authorized seller delivering accessories and your purchase receipt. You can find them in the internet under [www.kraenzle.com](http://www.kraenzle.com).

The guarantee is also void if the machine is used with exceeding the temperature and speed limits, a voltage below the required rating, with less than the required amount of water or with dirty water. Pressure gauge, nozzle, valves, sleeves, high pressure hose and spray equipment are wear parts and are not covered by the warranty.

## *Notes*



**I. Kränzle GmbH  
Elpke 97  
D - 33605 Bielefeld**

Subject to technical modifications. Order no.30.602 1

Reprint only allowed with the authorization of Kränzle

As date of 09/02/2013

■ Made  
■ in  
■ Germany

[www.kraenzle.com](http://www.kraenzle.com)