

# Operating manual

High pressure cleaners

**quadro 599 TS T**  
150 bar / 2175 psi

**quadro 799 TS T**  
180 bar / 2600 psi

**quadro 899 TS T**  
150 bar / 2175 psi



Read and conform safety instructions before use!

Keep instructions in a safe place for later use and pass them on to any future user.



# Technical data

Technical data	quadro 599 TST	quadro 799 TST	quadro 899 TST
Operating pressure, steplessly adjust.	10 - 150 bar	10 - 180 bar	10 - 150 bar
max. permissible overpressure	165 bar	200 bar	170 bar
Water output <sup>(*)1</sup>			
at 0 bar	10,0 l/min	14,0 l/min	15,0 l/min
at nominal pressure	9,5 l/min	13,0 l/min	14,5 l/min
Nozzle size			
(Flat jet)	25035	25045	25060
(Dirt killer)	035	045	060
Volume			
Water tank	10 l	10 l	10 l
max. inlet water temp. to water tank <sup>(*)2</sup>	max. 60 °C	max. 60 °C	max. 60 °C
Direct suction height	2,5 m	2,5 m	2,5 m
Hose drum	ja	ja	ja
High pressure hose	20 m	20 m	15 m
Electrical ratings	230 V/50 Hz 14 A	400 V/50 Hz 8,5 A	400 V/50 Hz 8,5 A
Motor speed adjust.	1400 U/min	1400 U/min	1400 U/min
Connect.wattage Inp.	P1: 3,2 kW	P1: 5,5 kW	P1: 5,5 kW
Output	P2: 2,3 kW	P2: 4,0 kW	P2: 4,0 kW
Weight (incl. access. with empty water tank)	60 kg	60 kg	60 kg
Dimensions incl. handle			
L x W x H in mm	780 x 395 x 870	780 x 395 x 870	780 x 395 x 870
Sound level acc. to DIN 45 635 (reg. working place) with dirtkiller	88 dB (A) 90 dB (A)	88 dB (A) 90 dB (A)	88 dB (A) 90 dB (A)
Guaranteed sound level $L_{WA}$	88 dB (A)	88 dB (A)	88 dB (A)
Vibrations at lance	ca. 20 N	ca. 20 N	ca. 22 N
Recoil at lance	2,0 m/s <sup>2</sup>	2,1 m/s <sup>2</sup>	2,1 m/s <sup>2</sup>
Order n°	40.431	40.432	40.434

Permissible tolerance for figures ± 5 % in acc. with VDMA uniform sheet 24411

<sup>(\*)1</sup> Min. water quantity to be supplied to the high pressure cleaner!  
(2 - 8 bar admission pressure)

<sup>(\*)2</sup> Direct suction is possible through by-passing of water tank!  
(see page 5)

# Description

## Dear customer

We would like to congratulate you on your new high pressure cleaner with integrated water tank and to thank you for the purchase.

To ease your introduction to the use of the cleaner, we have provided the following pages of explanations, tips and hints, which we ask you to read before using it for the first time.

The equipment will assist you professionally in all cleaning tasks, e.g.:

- facades
- flagstones
- terraces
- vehicles of all types
- stables
- machines etc.
- barrels and containers
- channels

## Contents

	Page
Technical data .....	2
Construction and components .....	4
Water system .....	5
Detergent / caring system .....	5
Lance and spay gun .....	5
High pressure hose and spray device .....	6
Unloader valve - safety valve .....	6
Delayed motor cut-out .....	7
Safety cut-out .....	7
Setting up / Location .....	7
Electrical connection .....	8
Brake .....	9
Brief operating instructions .....	9
This is what you've purchased .....	10
Preparation for use .....	11
External suction .....	13
When using detergents .....	14
To shut down the pump / Frost protection .....	14
Safety notes „This is prohibited !“ .....	15
Additional accessories .....	18
Small repairs .....	20
Spare parts lists .....	22
Wiring diagram .....	42
General rules / oil change / guarantee .....	44
Declaration of conformity .....	45
Inspection report .....	46

# Description

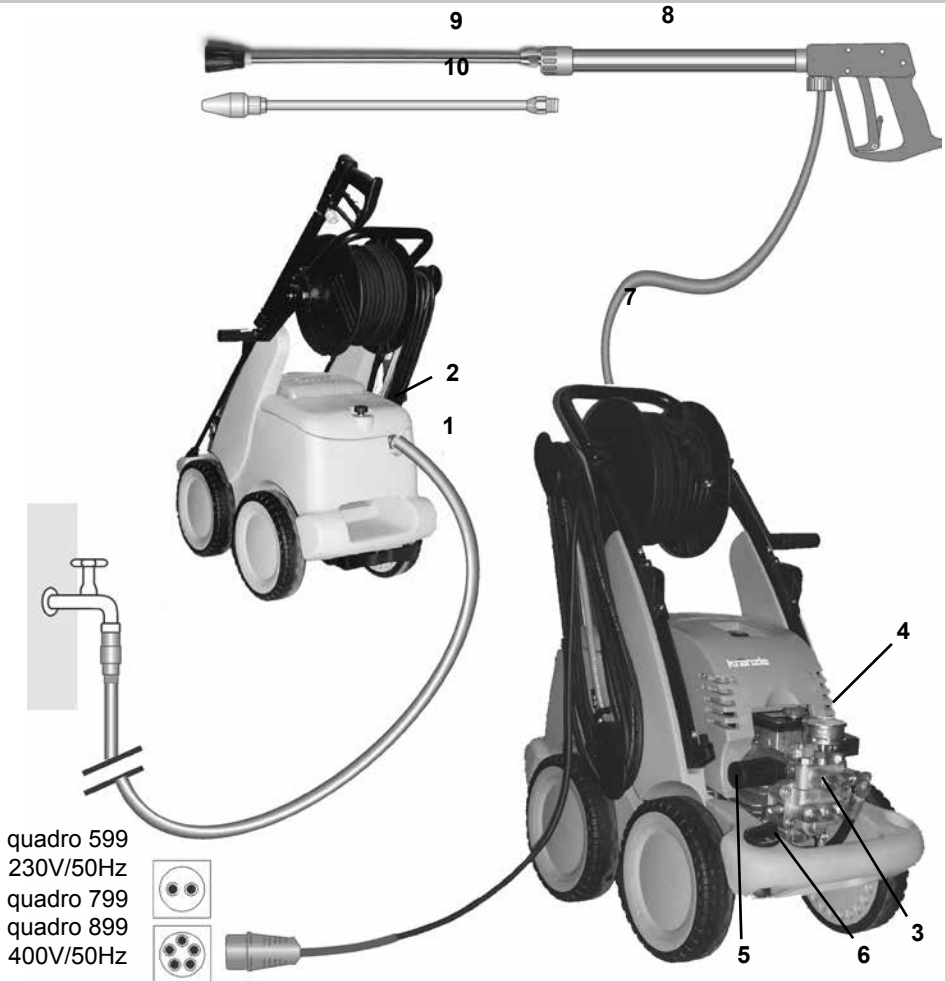

quadro 599  
230V/50Hz  
quadro 799  
quadro 899  
400V/50Hz



## Connection principle

The KRÄNZLE quadro 599 TST , 799 TST and 899 TST- high pressure cleaners are mobile machines with hose drum and 20m industrial hose.

The connection principle can be seen from the illustration.

## Components

- 1 Water inlet connection with filter
- 2 Cover for water tank
- 3 High pressure pump
- 4 Press. gauge with glycerin filling
- 5 Unloader valve - safety valve

- 6 Detergent valve
- 7 High pressure hose
- 8 Spray gun
- 9 Interchangeable lance with flat jet nozzle and nozzle protection
- 10 Interchangeable lance with dirtkiller

# Description

## Water system

The water must be lead to the high pressure cleaner under pressure (2 – 8 bar ad-mission pressure). A float valve regulates the water inlet. Then, the water is sucked by the high pressure pump from the water tank and supplied to the lance under the set pressure. The high pressure jet is formed by the nozzle at the end of the lance.

## Detergent and caring system

The high pressure pump can also suck a detergent/caring agent and mix it with the high pressure jet. The additive is sucked through the pump and brought in with the set pressure.

Insert the detergent hose into the detergent container and open the detergent valve (6). The detergent must have the ph-value 7-9 neutral.

The detergent discharges with the water at the high pressure nozzle.



**Only open the dosing valve, if the chemistry sieve is placed in a liquid. Sucked air leads to destruction of the pump seals !!!**

**The rules concerning the environment, refuse and ground water protection must be complied with!**

## Lance with spray gun

The machine can only be operated when the safety trigger is squeezed.

When the lever is squeezed, the spray gun opens. The liquid is then pumped to the nozzle. The spray pressure increases and quickly reaches the selected operating pressure. For the deairing of the system open and close the gun quickly a few times. When the trigger is released, the trigger gun closes and any further spraying of liquid from the lance is stopped and the pressure gauge must show 0 bar.

The increase in pressure when the trigger gun is closed causes the unloader valve-safety valve to open. The pump remains switched on and continues to pump liquid through the pump at reduced pressure. When the spray gun is opened, the unloader valve - safety valve closes and the pump resumes spraying from the lance with the selected operating pressure.



**The spray gun is a safety device. Repairs should only be performed by qualified persons. Should replacement parts be required, use only components authorized by the manufacturer.**

# Description

## High pressure hose and spraying device

The high pressure hose and spraying device supplied with the machine are made of high grade material. They are also optimized for the machine and marked as required by the appropriate regulations.



*If replacement parts are required, only such parts that are authorized by the manufacturer and which bear the markings required by the appropriate regulations may be used. The high pressure hose and spraying device must be connected in a pressure-tight manner. The high pressure hose may not be driven over, pulled excessively or twisted. Hose lines are wear parts. Guarantee is accepted only for manufacturing errors, not for external damages. High pressure hose lines and spraying equipment must not be repaired, but replaced by a new hose or spraying equipment.*

## Unloader valve - safety valve

The unloader valve - safety valve protects the machine from a build up of excess pressure, and is designed not to permit an excess pressure to be selected for operation. The limit nut on the handle is sealed with a spray coating.



**The operating pressure and spray rate can be steplessly adjusted by turning the handle. Replacements, repairs, new adjustments and sealing should only be performed by qualified persons.**



**Take care that all screw connections are pressure-tight. A leakage of gun, high-pressure hose or hose drum has to be repaired at once. Leakages lead to an increased wear and to the destruction of the delayed motor cut-out.**



### **Operator's task:**

**Prior to each usage of this liquid spraying device, the operator is obliged to check if all safety relevant parts are in perfect working condition. (e.g. safety valves, high-pressure hose, cables and connections, spraying devices, etc.)**

# Description



## Delayed motor cut-out

Frequent, work-necessitated switching on and off of motors on machines of this size puts a heavy load on the power network and causes increased wear on internal electrical parts. Therefore the motor of the new KRANZLE device only switches off 30 seconds after closing the gun and then goes to stand still. By opening the gun, the device is started again.

## Safety cut-out

If the device is accidentally not turned off after use or the pistol is not used for 20 minutes, the device automatically goes into the safety state via deactivating. By operating the main switch again, the device is activated again.



Replacements and inspection work should only be performed by qualified persons **when the machine is disconnected from the power supply, i.e. the plug pulled out from the electrical socket.**

## Setting up

### Location



Neither set up and operate the machine in rooms where there is a risk of fire or explosion nor put it into puddles. Do not use the machine under water. The device must not stand in the spray area of the high pressure jet.

## CAUTION !



Never suck in liquid containing solvents such as paint thinners, petrol, oil or similar liquid matter. **Pay attention to the instructions of the manufacturers of the cleaning agents.** The seals in the machine are not resistant to solvents! The spray of solvents is inflammable, explosive and poisonous.

## CAUTION !



When running your high pressure cleaner with hot water of 60° C raised temperatures occur. **Do not touch the machine without safety gloves!**

# Description



## Electrical connection

The machine is supplied with an electrical power cord with plug.

The mains plug must be fitted to a standard grounded socket with a 30mA residual current operated device. The socket must be protected with a 16A delay action fuse on the mains side.

KRÄNZLE quadro 599 TST = 230 Volt / 50 Hz

KRÄNZLE quadro 799 TST = 400 Volt / 50 Hz

KRÄNZLE quadro 899 TST = 400 Volt / 50 Hz (phase-sequence not significant)

When using an extension cable, this must have a grounded lead which is properly connected to the socket. The conductors in the extension cable must have a minimum cross section of 1.5 mm<sup>2</sup>. Plug connections must be of a spray-proof design and may not be located on a wet floor.

## **CAUTION !**

The use of extension cables which are too long may lead to malfunctions and start up difficulty. If the extension cable is longer than 10m it must have a min. cross section of 2.5mm<sup>2</sup>.

When using a cable drum, always keep the cable wound as far as possible.



# Description



## Brake



Brake not applied



Brake applied

## Brief operating instructions:

1. Connect high pressure hose with spray gun.
2. Connect to suitable water supply.
3. Connect current  
(quadro 599: 230V/50Hz AC;  
quadro 799 , 899: 400V/50Hz three-phase current).
4. Switch on machine and start cleaning.
5. After having completed the cleaning process, put main switch in zero position and by opening the gun, reduce the pressure in the high pressure hose.

Then, the high pressure hose can be rolled up.

- Only use clean water ! Protect from frost !

## **CAUTION !**

Please pay attention to the regulations of your waterworks company.

Because of the water tank, the device can be connected to any drinking water line without worries.

# ***This is what you've purchased:***



## **1. Dirtkiller**

Lance with nozzle protection and high pressure nozzle  
Flat jet 25°

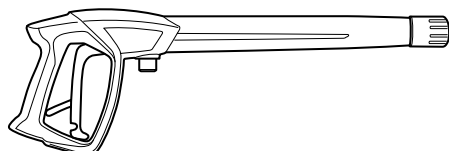

## **2. Spray gun M2000 with insulated handle and screw connection**

### **3. KRÄNZLE - High pressure cleaners quadro 599 TST and quadro 799 TST with hose drum and 20 m HP hose NW 6 with steel reinforcement**



## **4. Operating manual**



## **5. HP hose 20 m NW 6 with hose drum**

## **6. Collapsible crank for hose drum (already installed)**

## **7. Plug-in connection of water inlet parts and filter (already installed)**

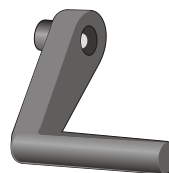

# Preparation for use



To control the high pressure cleaner put

1. the foot against the tilt bases and
2. then pull the device towards you.

## 1. Check oil level.

There are two possibilities for checking the oil level of the pump:

- a) Oil must be visible in the viewing window
- b) The oil level must be between the two markings on the oil dip stick.



To check the oil level, loosen the oil cover screw and take out the oil dip stick. The oil level must be between the two markings.

# Preparation for use

2. Connect the high pressure lance or dirtkiller to the spray gun.

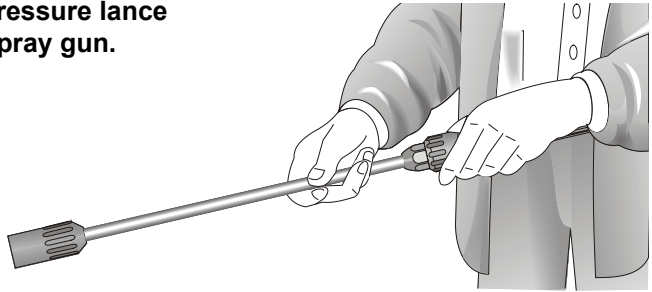

3. Unroll hose without kinks and connect with handgun and pump. Use max. 20 m HP hose.

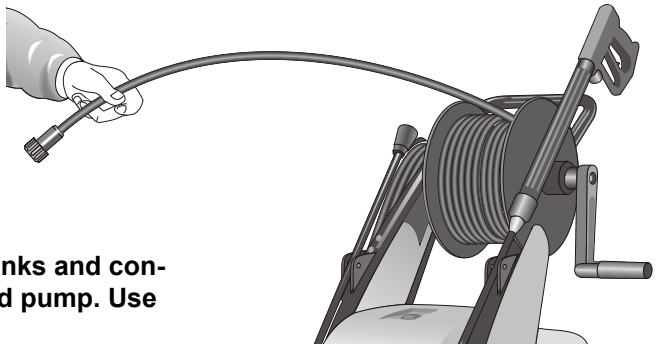

4. Connection of high pressure hose from device to lance.

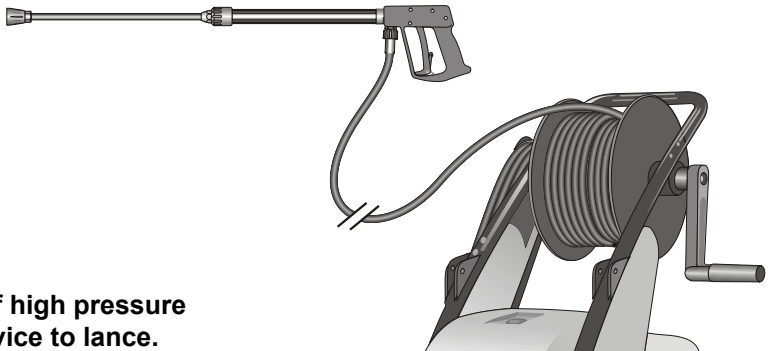

# Preparation for use

5. The machine must be connected to the water line with cold water or up to 60° C warm water (see page 2).

The hose cross section must be at least 3/4" = 16 mm (free passage). Filter 1 must always be clean.

Please make sure that the filter is clean before using your high pressure cleaner.



## CAUTION !



*When running your high pressure cleaner with hot water of 60° C raised temperatures occur. Do not touch the pump without safety gloves!*

## External suction

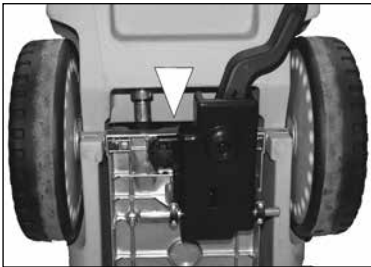

Undercarriage

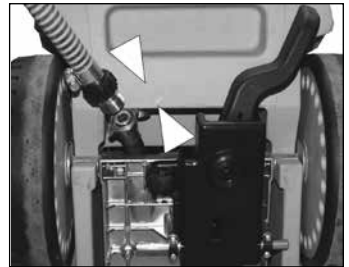

Undercarriage

If water is to be sucked from an external container for the high pressure cleaner, the connection hose between the high pressure pump and the water tank must be screwed off and the suction hose must be connected via a double nipple 3/4" (Order no.: 46.004) to the connection hose.

Make sure that the water is clean. Use the Kränzle suction hose with suction filter. (Order no. 15.038 3)

**Maximum suction height 2.5 m, maximum water temperature for direct suction: 60°C (see technical data on page 2)**

# To shut down the pump

## When using detergents

Put chemistry sieve number 5 into the detergent container. Open the detergent valve (6), then the detergent is sucked in. When closing the detergent valve, the chemistry supply is automatically closed. Allow detergent to act and then wash off. (see page 5).



**Note that you must always comply with the instructions provided by the manufacturer of the detergent (e.g. safety clothing) and the water protection regulations!**



**Only open the valve, if the chemistry sieve is in a liquid. Sucked in air leads to the destruction of the pump seals !!!**

Damages to the pump caused by sucked in air are not covered by the guarantee.



## To shut down the pump:

1. Switch off the machine. Device switch to „0“ position.
2. Cut off the water supply.
3. Open the spray gun briefly until the pressure is released.
4. Apply the safety catch on the spray gun.
5. Remove the water hose and spray gun.
6. Pull the plug from the socket.
7. Winter: store the pump in rooms above 0°C.
8. Clean the water filter.

# Safety notes

## Frost protection

Normally after operation, there is still some water in the device. Thus, you must take special measures to protect the device from frost.

### - **Completely drain the device**

For this purpose, separate the device from the water supply. Then, turn on the main switch and open the gun. Now, the pump presses the remaining water from the water tank and the pump. However, do not allow the device to operate without water for longer than one minute.

### - **Fill the device with antifreeze agent**

If the device is not operated for longer periods, especially over the winter, you should pump an antifreeze agent through the device. For this purpose, fill the anti-freeze agent into the water box and turn on the device. Wait with opened gun, until the agent comes from the nozzle.

**However, the best way to protect the device from frost is to store it at a frost-free location.**

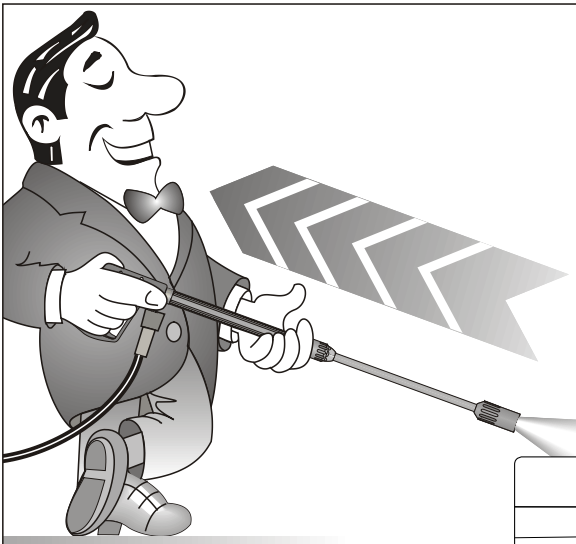

**As to the recoil -  
see notice on page 2!**

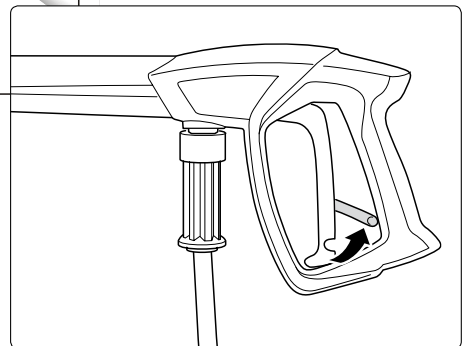

**Apply the safety catch on the spray gun after each use, in order to prevent unintentional spraying!**

# ***This is prohibited !***

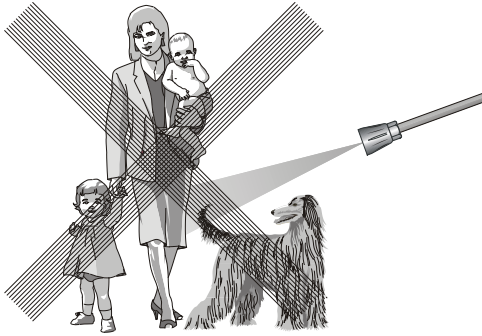

**Never direct the water jet at people or animals !**

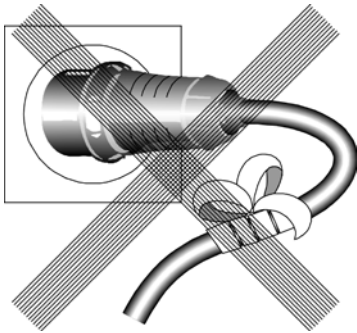

**Do not damage the power cable or repair it incorrectly!**

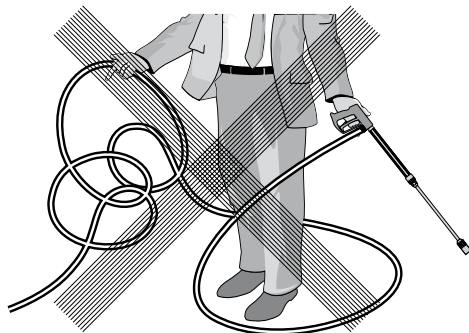

**Never pull the high pressure hose if it has formed kinks or "nooses"!  
Never pull the hose over sharp edges !**



# ***This is prohibited !***

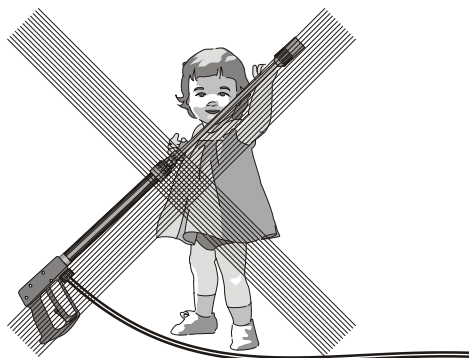

**Never allow children to use the high pressure cleaner !**

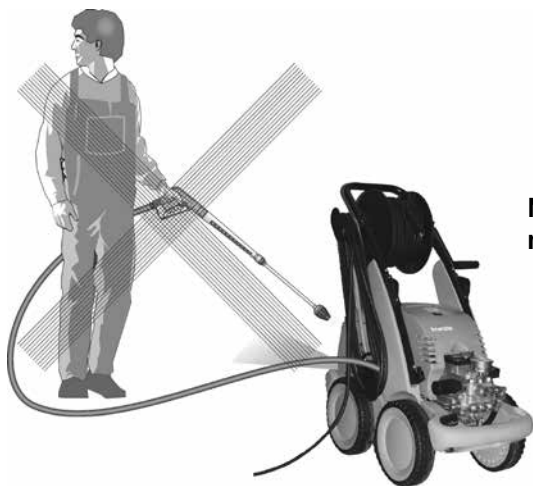

**Never direct the water jet at the machine itself !**

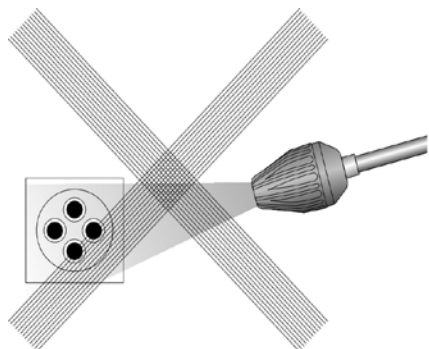

**Never direct the water jet at a power socket !**

## ***Additional accessories for ... (on demand)***

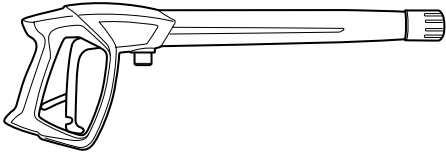

### **Rotary scrubbing brush**

Order No. 41.050 1

### **Drain and pipe cleaning hose**

10 m - Order No. 41.058.1

15 m - Order No. 41.058

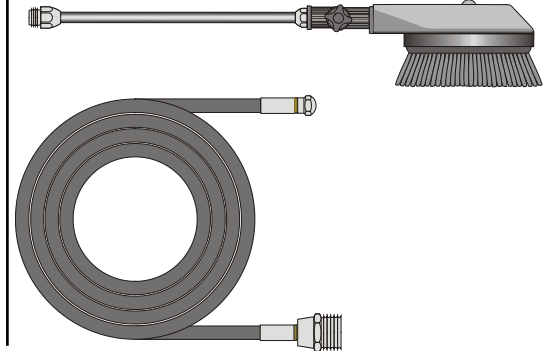

**Environmental, refuse disposal and water protection regulations must be observed when using the accessories!**

### **Guarantee**

The guarantee is only valid for material and manufacturing errors. Wearing does not fall within this guarantee.

The instructions in our operating manual must be complied with. The operating instructions form part of the guarantee. The Guarantee is void if other parts are used than genuine Kränzle accessory parts or genuine Kränzle spare parts.

For high-pressure cleaners sold to the user the guarantee period is 24 month.

For high-pressure cleaners sold for industrial use the guarantee period is 12 month. In the case of a guarantee please contact your dealer or authorized seller delivering accessories and your purchase receipt. You can find them in the internet under [www.kraenzle.com](http://www.kraenzle.com).

The guarantee is also void if the machine is used with exceeding the temperature and speed limits, a voltage below the required rating, with less than the required amount of water or with dirty water. Pressure gauge, nozzle, valves, sleeves, high pressure hose and spray equipment are wear parts and are not covered by the warranty.

## ... further combination possibilities

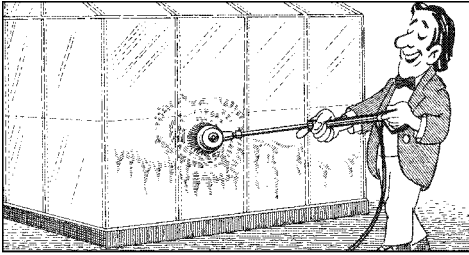

Car cleaning, glass, caravan, boat etc.:  
rotary washing brush with 40 cm extension  
and ST 30 nipple M22 x 1.5

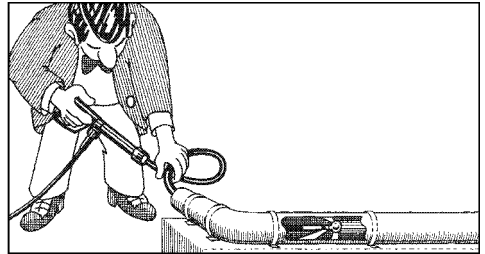

Cleaning pipes, channels and drains: pipe  
cleaning hose with KN nozzle and ST 30  
nipple M22 x 1.5

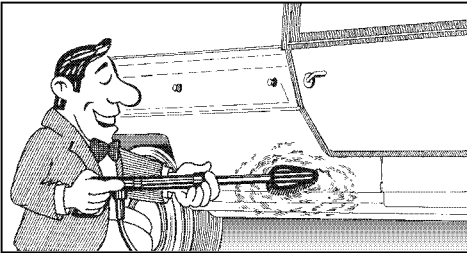

Cleaning cars and all smooth surfaces:  
brush with ST 30 nipple M22 x 1.5

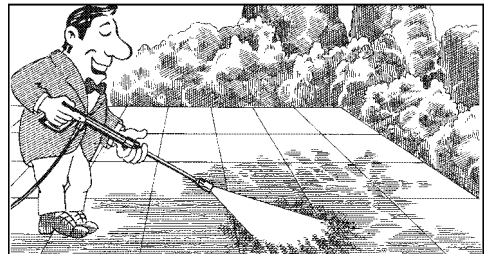

Rotary point sprayer for extreme soiling:  
Turbokiller with 40 cm extension and ST 30  
nipple M22 x 1.5

# Small repairs ...



## The nozzle is blocked!

- No water but the gauge shows full pressure !

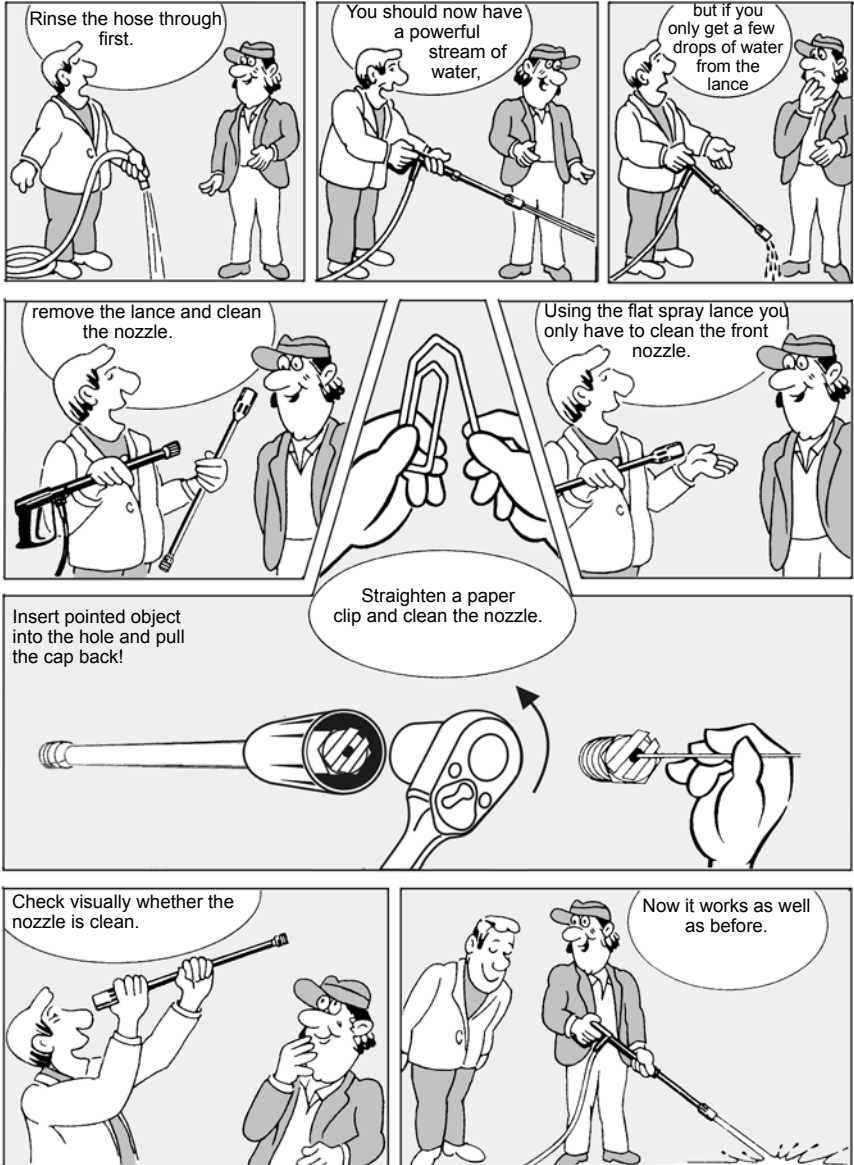

# do it yourself !

## Nozzle dirty or sticky!

- Pressure gauge does not show full pressure
- The high-pressure hose vibrates
- Water comes out in spurts.
- If you do not use the high-pressure cleaner for some time the valves can stick

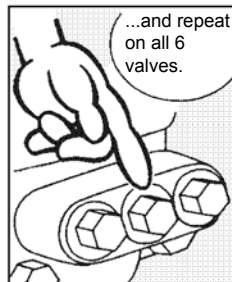
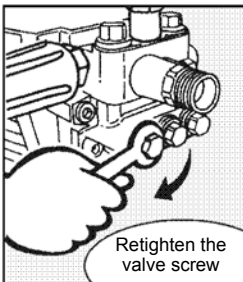
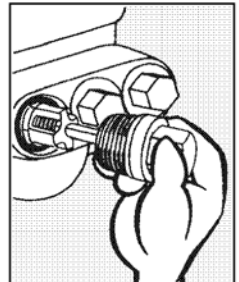
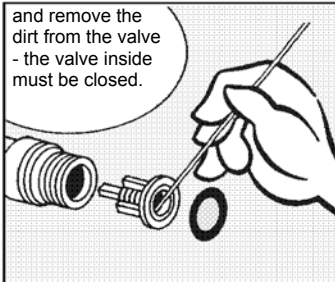
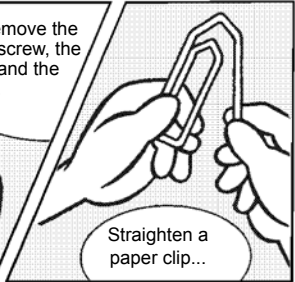
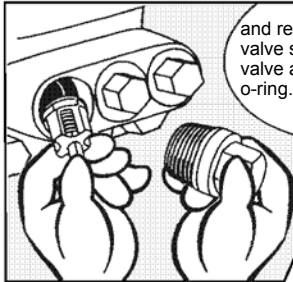
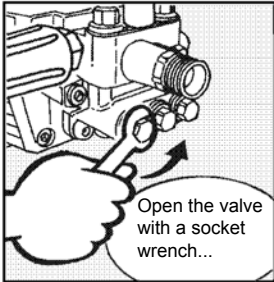
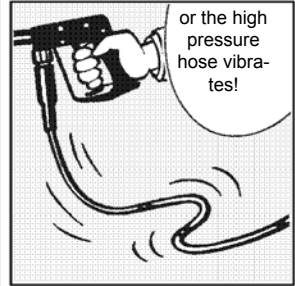
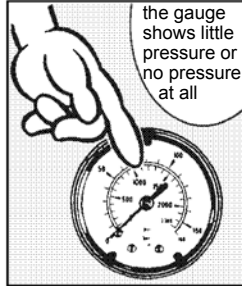
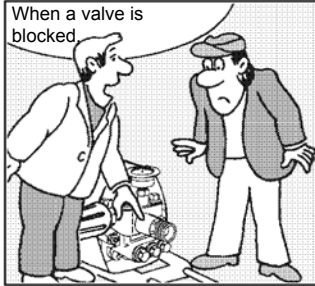

# Complete Assembly

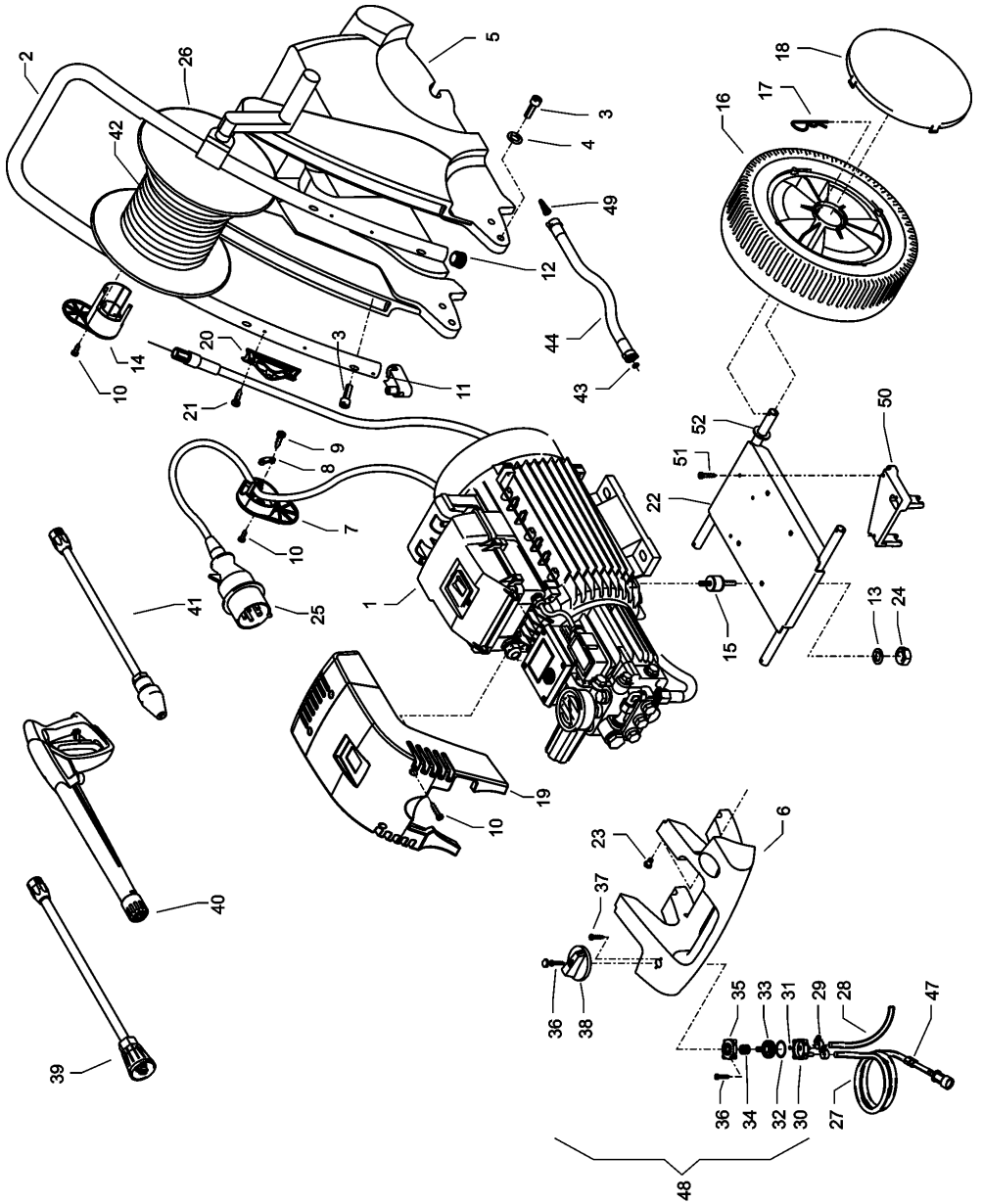

# quadro 599 TST - 899 TST

## Spare parts list KRÄNZLE quadro 599 TST - 899 TST Complete assembly

No	Description	Qty.	Ord.-No	No	Description	Qty.	Ord.-No
1.1	Motor-Pumpe ohne Elektrik für quadro 599 TST	1	46.085 1	25.1	Netzanschlusskabel 8m	1	44.036
1.2	für quadro 799 TST	1	46.085 2	26	Drehstrom (quadro 799/899 TST) Schlauchtrommel kpl.	1	46.081
1.3	für quadro 899 TST	1	46.085 3	27	Chemiesaugschlauch (Gewebe) mit Filter	1	42.621
1.4	Motor-Pumpe mit Elektrik für quadro 599 TST	1	46.086 1	28	Gewebeschnlauch 0,4m	1	42.622
1.5	für quadro 799 TST	1	46.086 2	29	Schlauchklemme 8 - 12	2	44.054 5
1.6	für quadro 899 TST	1	46.086 3	30	Gehäuse Waschmittelventil	1	44.145
2	Schubbügel	1	46.033	31	O-Ring 5 x 1,5 (Viton)	1	44.150
3	Schraube M6x35 DIN6912	8	46.024	32	O-Ring 28,24 x 2,62	1	44.149
4	Scheibe 6,4 DIN125	4	50.189	33	Regulierkolben Chemieventil	1	44.147
5	Wasserkasten	1	46.026	34	Edelstahlfeder 1,8 x 15 x 15	1	44.148
6	Lanzenablage	1	46.028	35	Deckel für Chemieventil	1	44.146
7	Kabelaufwicklung unten	1	42.611	36	Blechschaube 3,5 x 16	3	44.161
8	Zugentlastung	1	43.431	37	Blechschaube 3,5 x 19	2	44.162
9	Blechschaube 3,5 x 12	2	40.290	38	Drehgriff Chemieventil mit Blendkappe	1	44.151
10	Kunststoffschraube 5,0 x 30	2	41.412	39.1	Lanze mit Flachstrahldüse für 599 TST	1	12.392 2-M20035
11	Lanzenständer	1	46.021	39.2	Lanze mit Flachstrahldüse für 799 TST	1	12.392 2-M20045
12	Rohrstopfen dm25	1	46.022	39.3	Lanze mit Flachstrahldüse für 899 TST	1	12.392 2-D2506
13	Scheibe 8,4 DIN125	4	50.186	40	Pistole M2000	1	12.480
14	Kabelaufwicklung oben	1	42.612	41.1	Schmutz-Killer 035 bei quadro 599 TST	1	46.150
15	Gummipuffer 30 x 20	4	46.023	41.2	Schmutz-Killer 045 bei quadro 799 TST	1	46.150 1
16	Rad d250	4	46.010	41.3	Schmutz-Killer 06 bei quadro 899 TST	1	46.150 2
17	Federstecker	4	40.115 1	42	Hochdruckschlauch 20 m NW6	1	43.416 1
18	Radkappe	4	46.011	42.1	quadro 599, 799 TST	1	44.879
19.1	Frontplatte quadro 599 TST	1	46.014 1		Hochdruckschlauch 15 m NW8	1	
19.2	Frontplatte quadro 799 TST	1	46.014 2		quadro 899 TST	1	
19.3	Frontplatte quadro 899 TST	1	46.014 3	43	O-Ring 13 x 2,6	2	13.272
20	Lanzenhalter	2	42.610	44	Verbindungsschlauch	1	46.032
21	Blechschaube 3,9x13 DIN7981	5	41.078	47	Rückschlagventil für Chemiesaugschl.	1	44.240
22	Fahrgestell incl. Pos. 50, 51, 52	1	46.001	48	Chemieventil Kpl. Pos. 30-37	1	44.052
24	Elastic-Stop-Mutter M8	4	41.410	49	Wasserfilter	1	42.633
25	Netzanschlusskabel 5,75m	1	41.092	50	Aufnahme Bremse	1	46.042
	Wechselstrom (quadro 599 TST)			51	Schraube 5,0 x 20	3	43.018
				52	Scheibe 19 mm	6	43.830



# Water inlet and brake

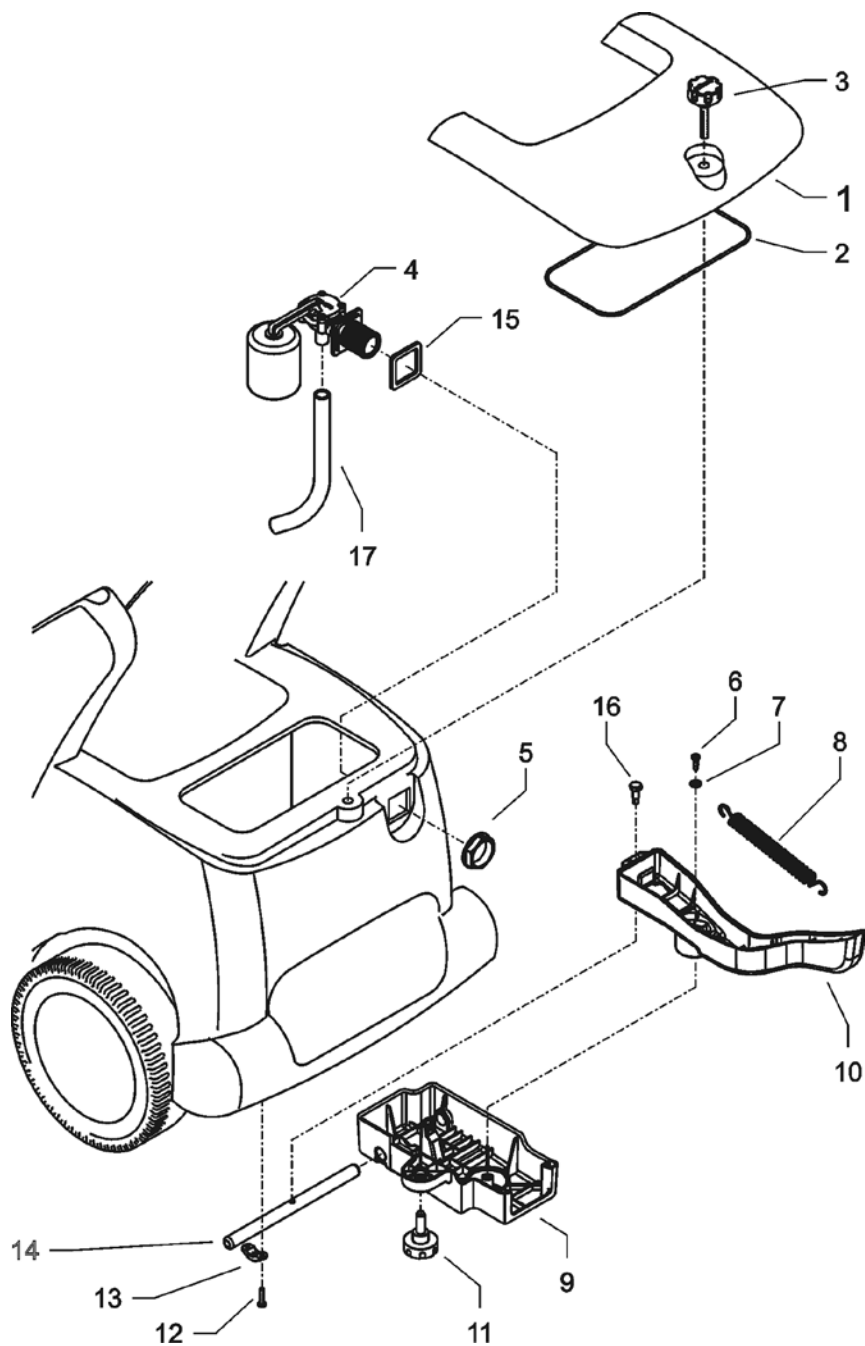



# **quadro 599 TST - 899 TST**

## **Spare parts list KRÄNZLE quadro 599 TST - 899 TST Water inlet and brake**

<b>No</b>	<b>Description</b>	<b>Qty.</b>	<b>Ord.-No</b>
1	Revisionsdeckel	1	46.027
2	Dichtung für Revisionsdeckel	1	46.030
3	Sterngriffschraube M6	1	46.031
4	Schwimmerventil	1	46.250
5	Mutter R3/4"	1	46.258
6	Kunststoffschraube 5x14	1	43.426
7	Scheibe 5,3 DIN9021	1	50.152
8	Zugfeder	1	46.020
9	Deckel Bremse	1	46.016
10	Hebel Bremse	1	46.017
11	Sternschraube M8	1	50.168
12	Schraube 3,5x14	4	44.525
13	Schelle	2	43.431
14	Bolzen für Bremse	1	46.018
15	Dichtung für Schwimmerventil	1	46.261
16	Bundschraube	1	46.019
17	Einströmschlauch	1	46.043
	Bremse kpl.		46.080
	bestehend aus: Pos. 6-14		

# Pump motor

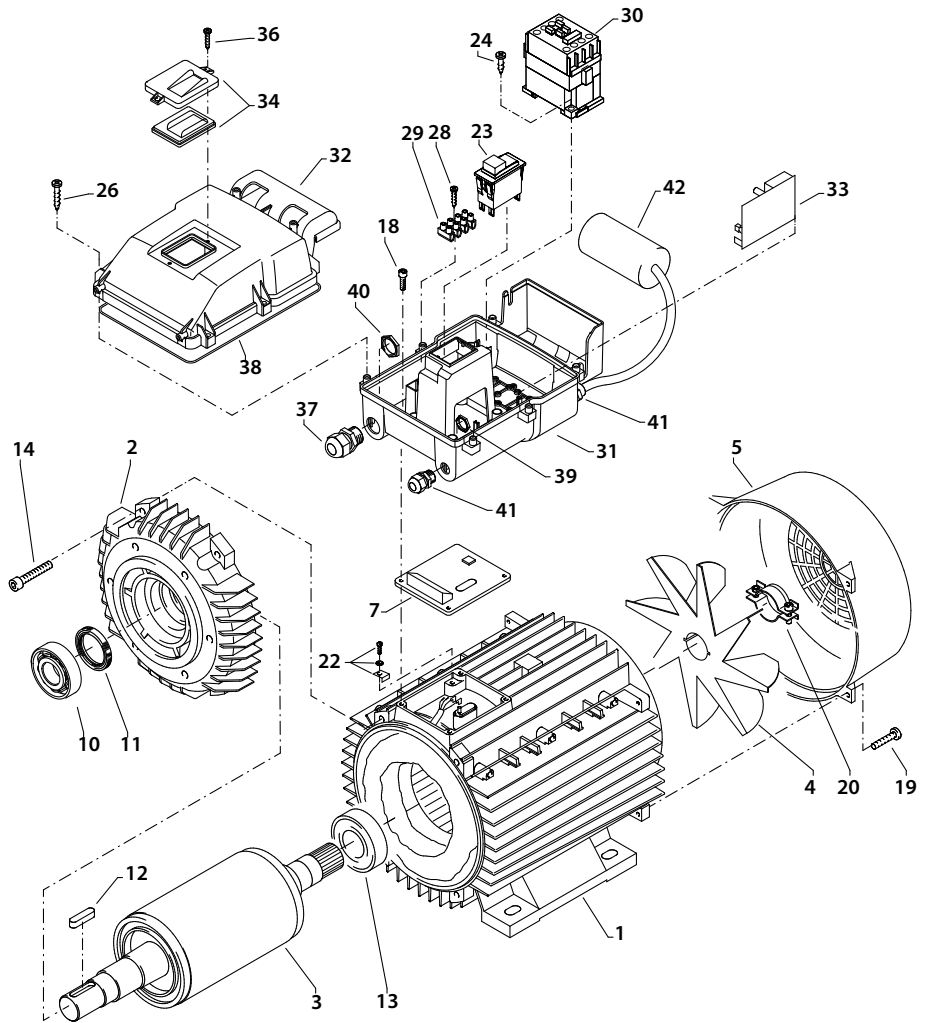

# quadro 599 TST

## Spare parts list KRÄNZLE quadro 599 TST Pump motor

No	Description	Qty.	Ord.-No
1	Stator BG100 2,3kW 230V / 50Hz	1	40.720
2	A-Lager Flansch	1	40.700
3	Rotor BG100 230V / 50Hz	1	40.703 1
4	Lüfterrad BG100	1	40.702
5	Lüfterhaube BG100	1	40.701
7	Flachdichtung	1	43.030
10	Schräggugellager 7306	1	40.704
11	Öldichtung 35 x 47 x 7	1	40.080
12	Passfeder 8 x 7 x 28	1	40.459
13	Kugellager 6206 - 2Z	1	40.538
14	Innensechskantschraube M 6 x 30	4	43.037
18	Innensechskantschraube M 5 x 12	4	41.019 4
19	Schraube M 4 x 12	4	41.489
20	Schelle für Lüfterrad BG100-112	1	40.535
22	Erdungsschraube kpl.	1	43.038
23	Schalter 14,5 A Drucktasten	1	46.046
24	Kunststoffschraube 4,0 x 16	4	43.417
26	Kunststoffschraube 5,0 x 25	6	41.414
28	Kunststoffschraube 3,5 x 20	2	43.415
29	Lüsterklemme 5-pol.	1	43.326 1
30	Schütz 230V 50/60 Hz	1	46.005
31	Schaltkasten Unterteil	1	46.012
32	Schaltkasten Deckel	1	46.013
33	Steuerplatine Abschaltverz. 230V / 50Hz	1	42.564
34	Klemmrahmen mit Schalterabdichtung	1	43.453
36	Blechschraube 3,5 x 14	2	44.525
37	PG 16-Verschraubung	1	41.419 1
38	Dichtung für Schaltkastendeckel	1	46.013 1
39	Gegenmutter für PG9-Verschraubung	2	41.087 1
40	Gegenmutter für PG16-Verschraubung	1	44.119
41	PG 9 - Verschraubung	1	42.541
42	Kondensator 60µF	1	41.148
43	PG 9 - Verschraubung reduziert	1	41.087
	<b>Switch box compl. items 23 - 43</b>		<b>46.082</b>
	<b>Motor compl. without switch items 1 - 22</b>		<b>24.085</b>

# Pump motor

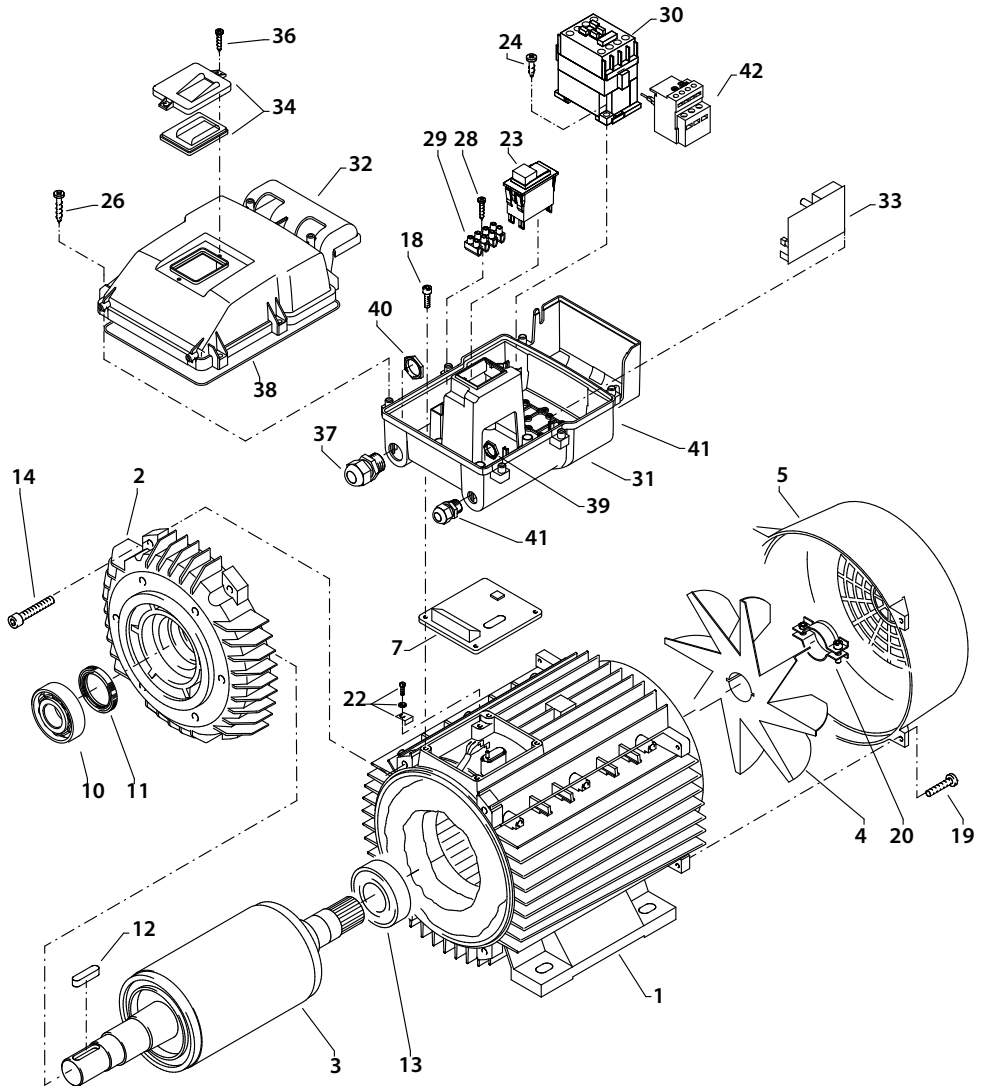

# quadro 899 TST

## Spare parts list KRÄNZLE quadro899 TST Pump motor

No	Description	Qty.	Ord.-No
1	Stator 100 4,0kW 400V / 50Hz	1	40.710
2	A-Lager Flansch	1	40.700
3	Rotor 100 400V / 50Hz	1	40.703
4	Lüfterrad BG100	1	40.702
5	Lüfterhaube BG 100	1	40.701
7	Flachdichtung	1	43.030
10	Schrägkugellager 7306	1	40.704
11	Öldichtung 35 x 47 x 7	1	40.080
12	Passfeder 8 x 7 x 28	1	40.459
13	Kugellager 6206 - 2Z	1	40.538
14	Innensechskantschraube M 6 x 30	4	43.037
18	Innensechskantschraube M 5 x 12	4	41.019 4
19	Schraube M 4 x 12	4	41.489
20	Schelle für Lüfterrad BG100-112	1	40.535
22	Erdungsschraube kpl.	1	43.038
23	Schalter mit Drucktasten	1	42.644
24	Kunststoffschraube 4,0 x 16	4	43.417
26	Kunststoffschraube 5,0 x 25	6	41.414
28	Kunststoffschraube 3,5 x 20	2	43.415
29	Lüsterklemme 5-pol.	1	43.326 1
30	Schütz 100-C12KN10 3x400V 50/60 Hz	1	46.005 1
31	Schaltkasten Unterteil	1	46.012
32	Schaltkasten Deckel	1	46.013
33	Steuerplatine Abschaltverz.	1	42.563
34	Klemmrahmen mit Schalterabdichtung	1	43.453
36	Blechschrabe 3,5 x 14	2	44.525
37	PG 16-Verschraubung	1	41.419 1
38	Dichtung für Schaltkastendeckel	1	42.525
39	Gegenmutter für PG9-Verschraubung	1	41.087 1
40	Gegenmutter für PG16-Verschraubung	1	44.119
41	PG 9 - Verschraubung	1	42.541
42	Überstromauslöser 3-polig 9 – 12,5 A	1	42.641 2
<b>Switch box compl. items 23 - 42</b>			<b>46.083</b>
<b>Motor compl. without switch items 1 - 22</b>			<b>24.080</b>

# Transmission unit

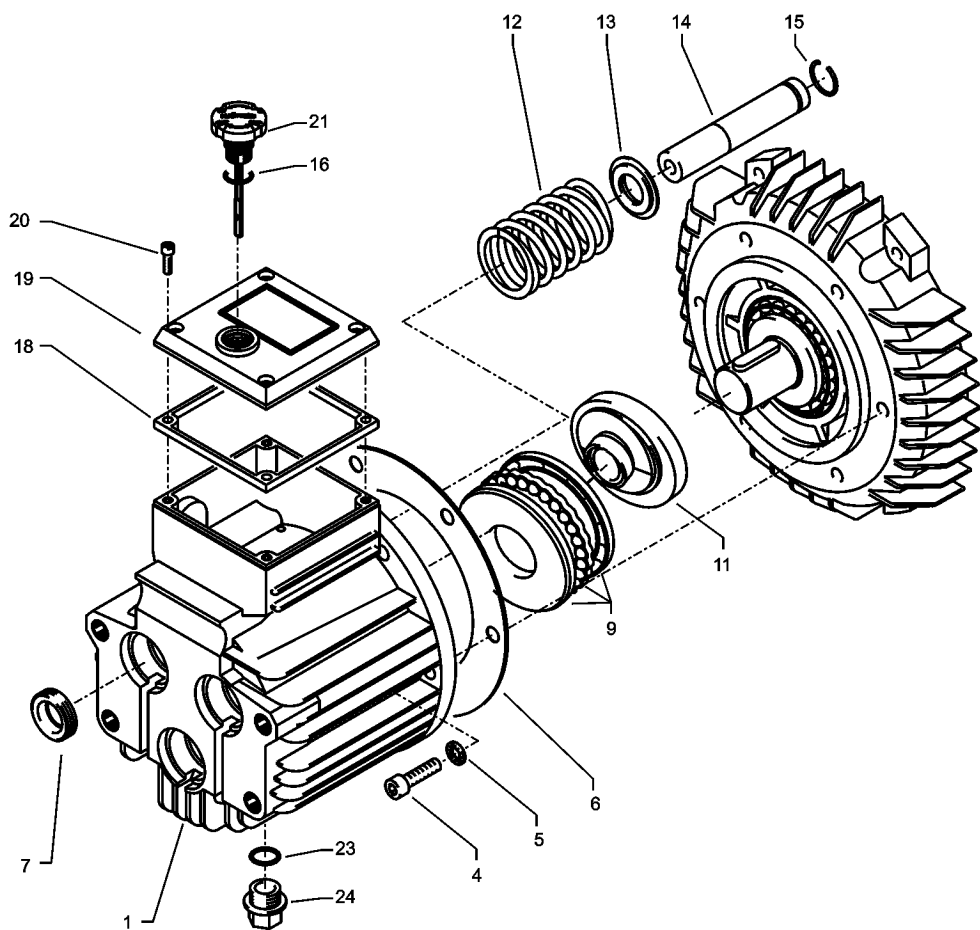

# quadro 599 TST

## Spare parts list KRÄNZLE quadro 599 TST Pump transmission unit for AM-pump

No	Description	Qty.	Ord.-No
1	Ölgehäuse mit Öldichtungen	1	40.452
4	Innensechskantschraube M 8 x 25	6	40.053
5	Sicherungsscheibe	6	40.054
6	Flachdichtung	1	40.511
7	Öldichtung 18 x 28 x 7	3	41.031
9	Axial-Rillenkugellager AM	1	40.462
11	Taumelscheibe 7,66" quadro 599	1	40.460-7,66
12	Plungerfeder	3	40.506
13	Federdruckscheibe	3	40.454
14	Plunger 18mm (AM-Pumpe)	3	40.455
15	Sprengring	3	41.035
16	O-Ring 14 x 2	1	43.445
18	Flachdichtung	1	41.019 3
19	Deckel	1	41.023 1
20	Innensechskantschraube M 5 x 12	4	41.019 4
21	Ölmessstab (AM-Pumpe)	1	40.463
23	O-Ring 13,94 x 2,62	1	42.167
24	Ölablasstopfen R 3/8"	1	42.019
	Transmission unit AM compl. with ball bearing for quadro 599 consisting of: Items 1-24		46.087 1-7,66

# Transmission unit

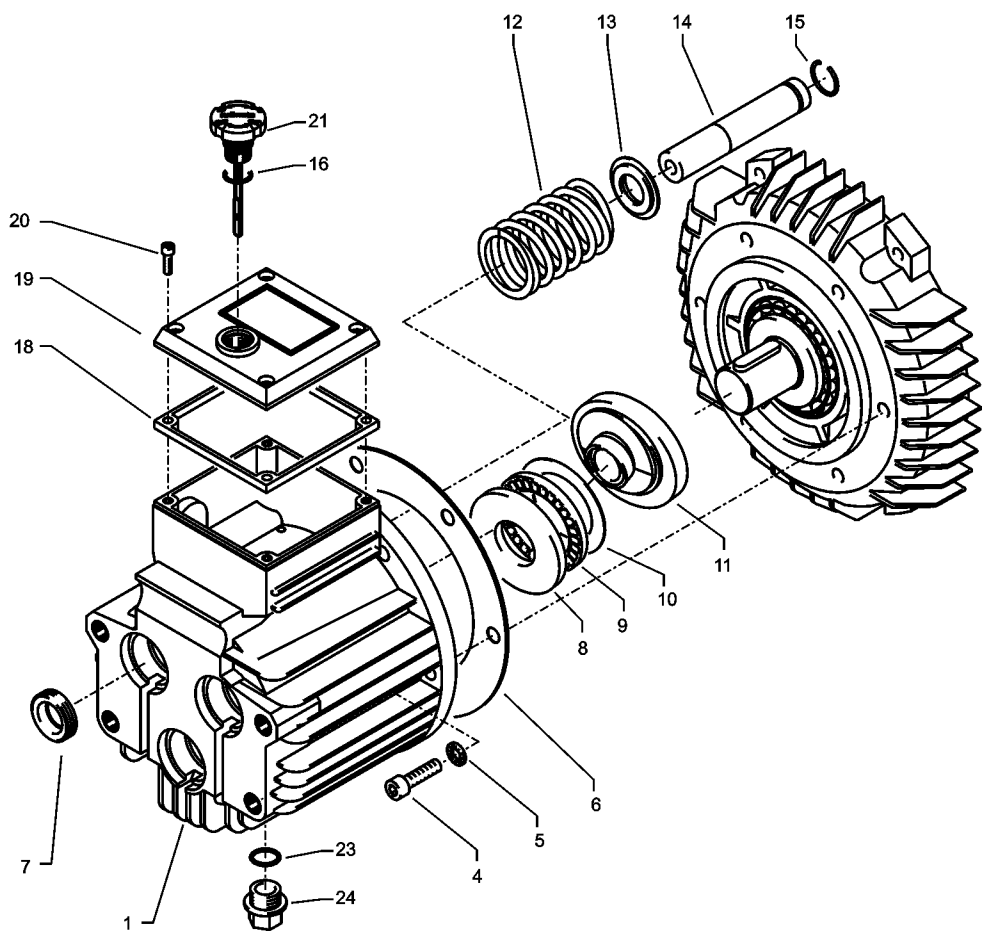



# quadro 799 TST

## Spare parts list KRÄNZLE quadro 799 TST Pump transmission unit for AM-pump

No	Description	Qty.	Ord.-No
1	Ölgehäuse mit Öldichtungen	1	40.452
4	Innensechskantschraube M 8 x 25	6	40.053
5	Sicherungsscheibe	6	40.054
6	Flachdichtung	1	40.511
7	Öldichtung 18 x 28 x 7	3	41.031
8	Wellenscheibe	1	40.043
9	Axial-Rollenkäfig	1	40.040
10	AS-Scheibe	1	40.041
11	Taumelscheibe 10,8° quadro 799	1	40.460-10,8
11.1	Taumelscheibe 12,5° quadro 899	1	40.460-12,5
12	Plungerfeder	3	40.506
13	Federdruckscheibe	3	40.454
14	Plunger 18mm (AM-Pumpe)	3	40.455
15	Sprengring	3	41.035
16	O-Ring 14 x 2	2	43.445
18	Flachdichtung	1	41.019 3
19	Deckel	1	41.023 1
20	Innensechskantschraube M 5 x 12	4	41.019 4
21	Ölmesstab (AM-Pumpe)	1	40.463
23	O-Ring 13,94 x 2,62	1	42.167
24	Ölablassstopfen R 3/8"	1	42.019
	Antrieb AM kpl. mit Rollenlager für quadro 799 bestehend aus: Pos. 1-24		46.087 2-10,8
	Antrieb AM kpl. mit Rollenlager für quadro 899 bestehend aus: Pos. 1-24		46.087 2-12,5

# Unloader valve and pressure switch

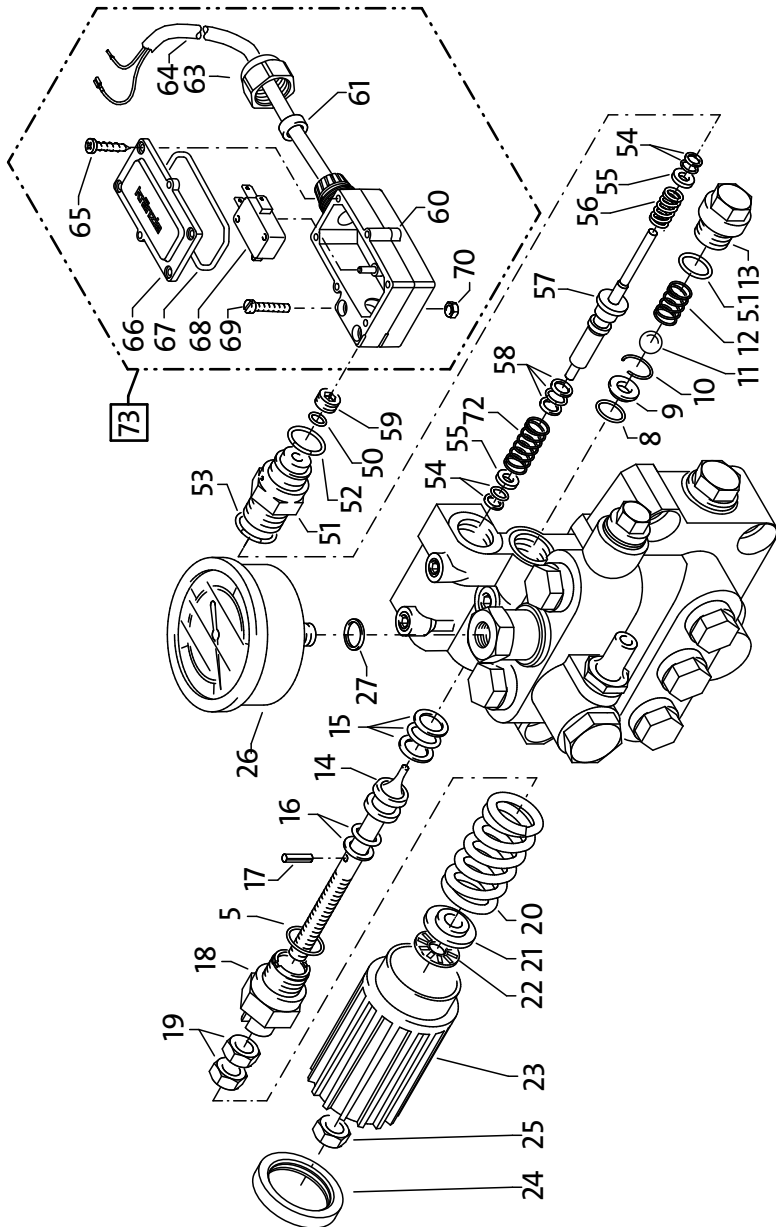

# quadro 599 TST - 899 TST

## Spare parts list KRÄNZLE quadro 599 TST - 899 TST Unloader valve and pressure switch

No	Description	Qty.	Ord.-No	No	Description	Qty.	Ord.-No
5	O-Ring 16 x 2	1	13.150	55	Stützscheibe	2	15.015 1
5.1	O-Ring 13,94 x 2,62	1	42.167	56	Edelstahlfeder	1	15.016
8	O-Ring 11 x 1,44	1	12.256	57	Steuerstößel	1	15.010 2
9	Edelstahlsitz	1	14.118	58	Parbaks 7 mm	1	15.013
10	Sicherungsring	1	13.147	59	Stopfen M 10 x 1 (durchgebohrt)	1	13.385 1
11	Edelstahlkugel	1	13.148	60	Gehäuse Elektroschalter	1	15.007
12	Edelstahlfeder	1	14.119	61	Gummimanschette PG 9	1	15.020
13	Verschlusssschraube	1	14.113	62	Scheibe PG 9	1	15.021
14	Steuerkolben	1	14.134	63	Verschraubung PG 9	1	15.022
15	Parbaks 16 mm	1	13.159	64	PVC-Kabel 2x 1,0 mm <sup>2</sup>	1	42.505
16	Parbaks 8 mm	1	14.123	65	Blechschrube 2,8 x 16	6	15.024
17	Spannstift	1	14.148	66	Deckel Elektroschalter	1	15.008
18	Kolbenführung spezial	1	42.105	67	O-Ring 44 x 2,5	1	15.023
19	Kontermutter M 8 x 1	2	14.144	68	Mikroschalter	1	15.018
20	Ventilfeder schwarz	1	14.125	69	Zylinderschraube M 4 x 20	2	15.025
21	Federdruckscheibe	1	14.126	70	Sechskant - Mutter M 4	2	15.026
22	Nadellager	1	14.146	72	Druckfeder 1 x 8,6 x 30	1	40.520
23	Handrad AM-Pumpe	1	40.457	<b>73</b>	<b>Druckschalter kpl.</b>		<b>41.300 5</b>
24	Kappe Handrad AM-Pumpe	1	40.458		Steuerkolben kpl. mit Handrad		40.490
25	Elastic-Stop-Mutter M 8 x 1	1	14.152		Pos. 5, 14-25		
26	Manometer 0-250 Bar	1	15.039		Rep.-Satz Druckschaltermechanik	15.009 3	
27	Aluminium-Dichtring	2	13.275		1x Pos. 51, 1x Pos. 52, 1x Pos. 53,		
50	O-Ring 3,3 x 2,4	1	12.136		3x Pos. 54, 1x Pos. 55, 1x Pos. 56,		
51	Führungsteil Steuerstößel	1	15.009 1		1x Pos. 57, 1x Pos. 58, 1x Pos. 59		
52	O-Ring 13 x 2,6	1	15.017		Druckschalter kpl. Pos. 54 - 70		41.300 5
53	O-Ring 14 x 2	1	43.445				
54	Parbaks 4 mm	2	12.136 2				

# Valve housing

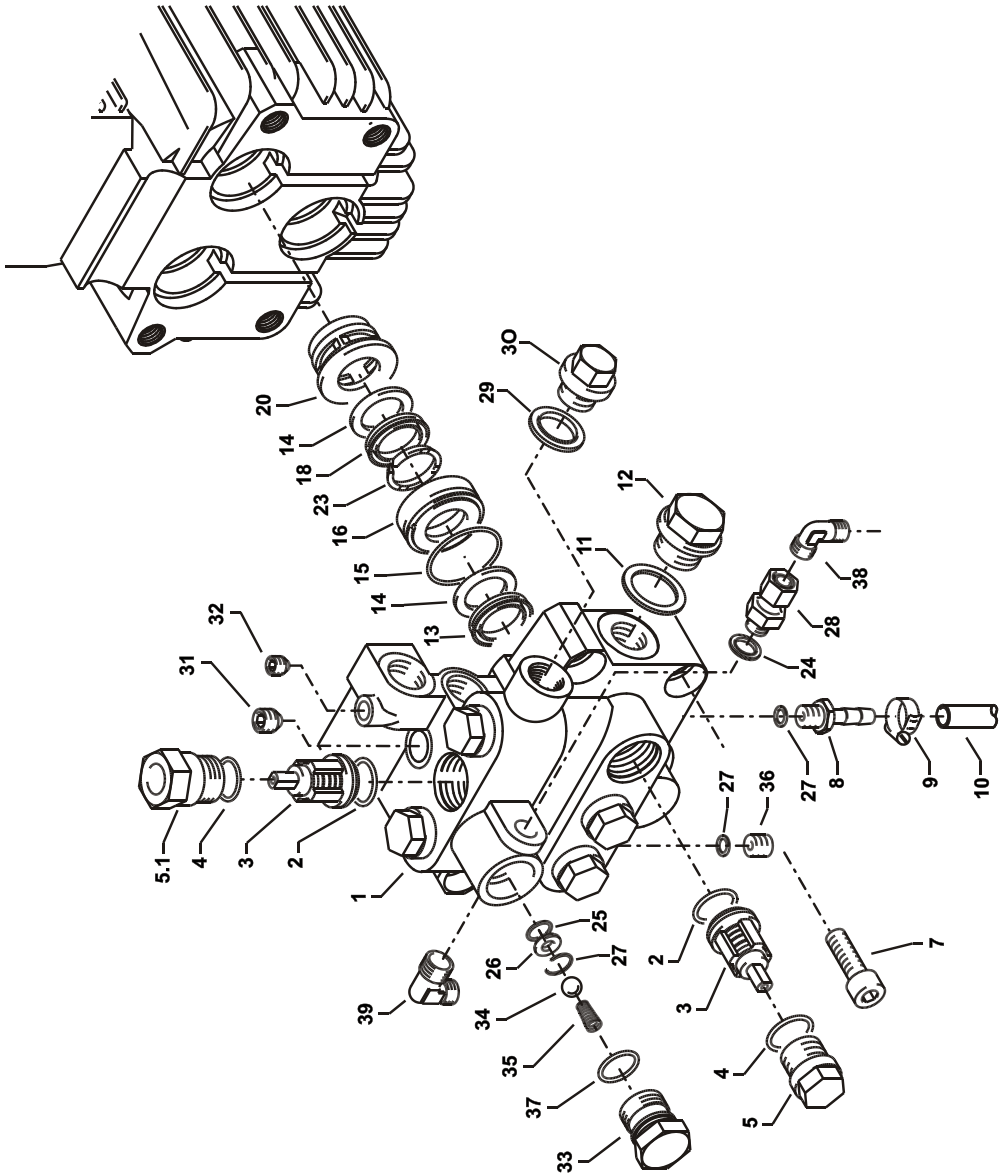

# quadro 599 TST - 899 TST

## Spare parts list KRÄNZLE quadro 599 TST - 899 TST Valve housing for integrated AM-pump

No	Description	Qty.	Ord.-No	No	Description	Qty.	Ord.-No
1	Ventilgehäuse AM-Pumpe	1	40.451 1	27	Aluminium-Dichtring	4	13.275
2	O-Ring 15 x 2	6	41.716	28	Ausgangsteil Pumpe R1/4" x 12	1	46.039
3	Ventile (grün)	6	41.715 1	29	Kupferring	1	42.104
4	O-Ring 16 x 2	6	13.150	30	Dichtstopfen R1/4" mit Bund	1	42.103
5	Ventilstopfen	5	41.714	31	Dichtstopfen M10 x 1	1	43.043
5.1	Ventilstopfen mit R1/4" IG	1	42.102	32	Dichtstopfen M 8 x 1	2	13.158
7	Innensechskantschraube M10 x 35	4	42.509 1	33	Ausgangsteil	1	40.522
8	Schlauchnippel R1/4" x 8	1	46.038	34	Edelstahlkugel Ø10	1	12.122
9	Schlauchschele 7 - 10	1	44.054	35	Rückschlagfeder „K“	1	14.120 1
10	Chemiesaugschlauch mit Filter	1	46.038 1	36	Stopfen R1/4"	1	13.387
11	Dichtring	1	40.019	37	O-Ring 18 x 2	1	40.016
12	Stopfen 3/8"	1	40.018	38	Ermetowinkel 12L x 12L	1	42.630
13	Gewebemanschette 18 x 26 x 5,5/3	3	41.013 1	39	Ermetowinkel R3/8" x 12L	1	44.092
14	Backing 18 mm	6	41.014		Ventilgehäuse kpl. ohne Manometer	46.084	
15	O-Ring	3	40.026		bestehend aus: Pos. 1 - 8; Pos. 11 - 39		
16	Leckagering 18 mm	3	41.066		Reperatur - Sätze:		
18	Manschette 18 x 26 x 4/2	3	41.013		Rep.-Satz Manschetten 18 mm	41.049 1	
20	Zwischenring 18 mm	3	41.015 2		bestehend aus je 3x Pos. 13; 6x Pos. 14;		
23	Druckring	3	41.018		3x Pos. 15; 3x Pos. 23; 3x Pos. 18		
24	Usit-Ring	1	12.387		Rep.-Satz Ventile für APG-Pmppe		
25	O-Ring 11 x 1,5	1	12.256		bestehend aus je 6x Pos. 2; 6x Pos. 3;		
26	Edelstahlsitz Ø 7	1	14.118		6x Pos. 4		
27	Sprengring	1	13.147				41.748 1

# Hose drum

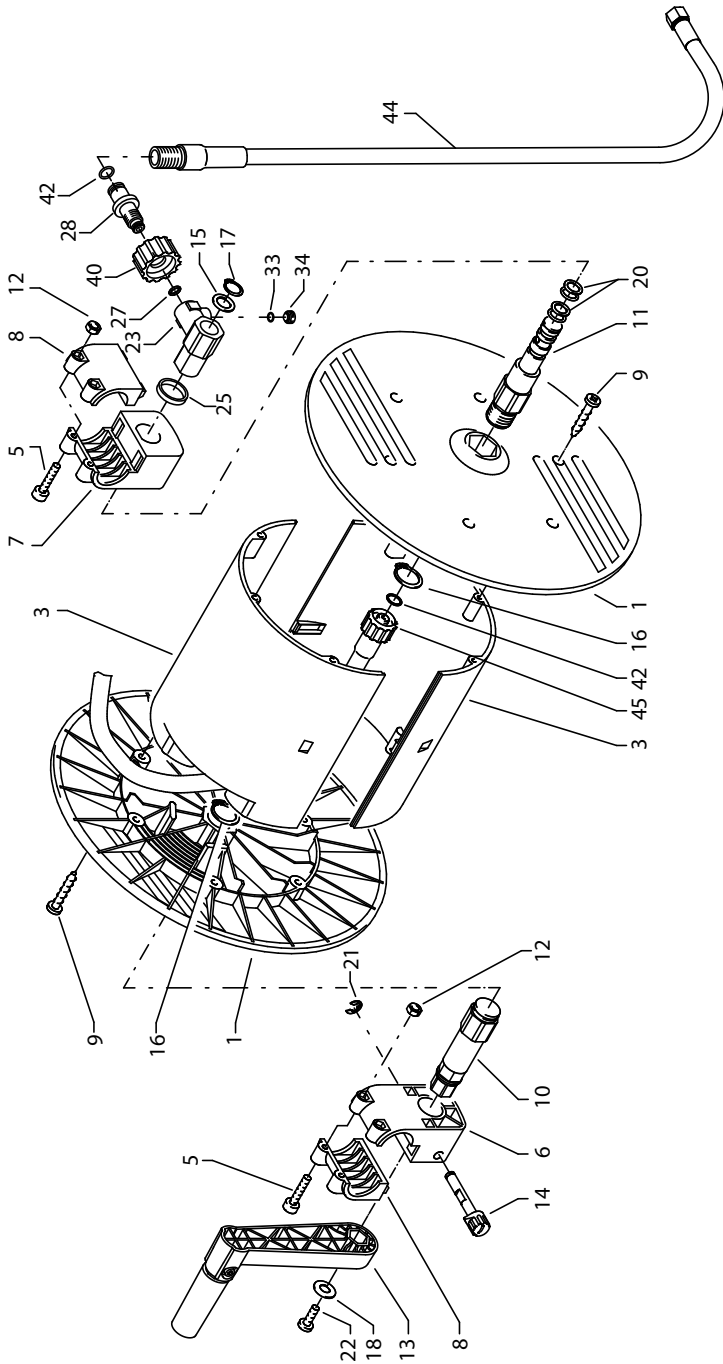

# quadro 599 TST - 899 TST

## Spare parts list KRÄNZLE quadro 599 TST - 899 TST Hose drum

No	Description	Qty.	Ord.-No	No	Description	Qty.	Ord.-No
1	Seitenschale	2	46.201	23	Drehgelenk	1	40.167
3	Trommelteil	2	46.202	24	Anschlusssteil	1	40.308
5	Innensechskantschraube M 4 x 25	4	40.313	25	Distanzring	1	40.316
6	Lagerklotz mit Bremse	1	40.306 1	27	O-Ring 6,5 x 2	1	40.585
7	Lagerklotz links	1	40.305 1	28	Anschlussstück	1	40.308
8	Klemmstück	2	40.307 1	33	O-Ring 6 x 1,5	1	13.386
9	Kunststoffschraube 5,0 x 20	12	43.018	34	Stopfen M 10 x 1	1	13.385
10	Antriebswelle	1	46.204	40	Überwurfmutter	1	13.276 2
11	Welle Wasserführung	1	46.203	42	O-Ring 9,3 x 2,4	4	13.273
12	Elastic-Stop-Mutter M 4	4	40.111	44	Verbindungsschlauch	1	46.037
13	Handkurbel	1	40.320 0	45	Hochdruckschlauch NW6 20 m	1	43.416 1
14	Verriegelungsbolzen	1	40.312		quadro 599, 799 TST		
15	Scheibe MS 16 x 24 x 2	1	40.181	45.1	Hochdruckschlauch NW8 15 m	1	44.879
16	Wellensicherungsring 22 mm	2	40.117		quadro 899 TST		
17	Wellensicherungsring 16 mm	1	40.182				
18	Unterlegscheibe Ø 6,4	1	50.189				
20	Parbaks 16 mm	2	13.159				
21	Sicherungsscheibe 6 DIN6799	1	40.315				
22	Schraube M 5 x 10	1	43.021				
					<b>Schlauchtrommel</b> kpl. ohne Schlauch		<b>46.081</b>
					bestehend aus Pos. 1 - 42		

# Lance

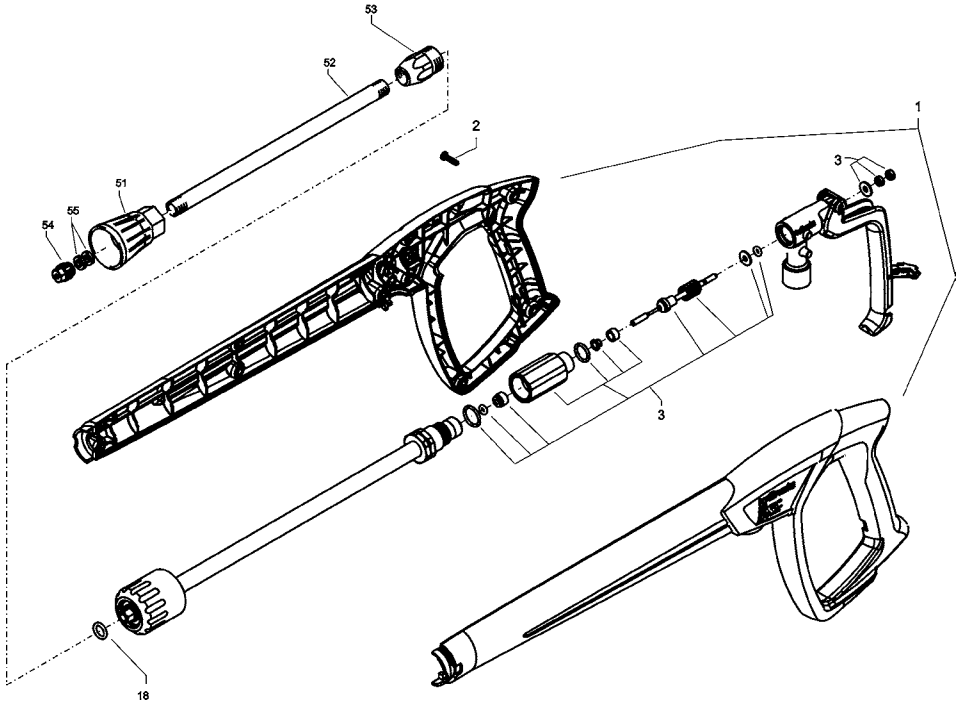

No	Description	Qty.	Ord.-No
1	Pistolenschale re+li	1	12.450
2	Schraube 3,5 x 14	10	44.525
3	Reparatursatz M2000	1	12.454
18	O-Ring 9,3 x 2,4	1	13.273

51	Düsenschutz	1	26.002 1
52	Rohr 500 mm; bds. M12x1	1	41.527 1
53	ST 30 Nippel M 22 x 1,5 / M12x1 m. ISK	1	13.363
54	Flachstrahldüse 20035 (quadro 599)	1	M20035
54.1	Flachstrahldüse 20045 (quadro 799)	1	M20045
54.2	Flachstrahldüse 2506 (quadro 899)	1	D2506
55	Aluminium-Dichtring 8,3x11,3x2	2	13.275 1

**Lanze kpl. mit HD-Düse M20035**

**12.394-M20035**

**Lanze kpl. mit HD-Düse M20045**

**12.394-M20045**

**Lanze kpl. mit HD-Düse D2506**

**12.394-D2506**



# Dirtkiller

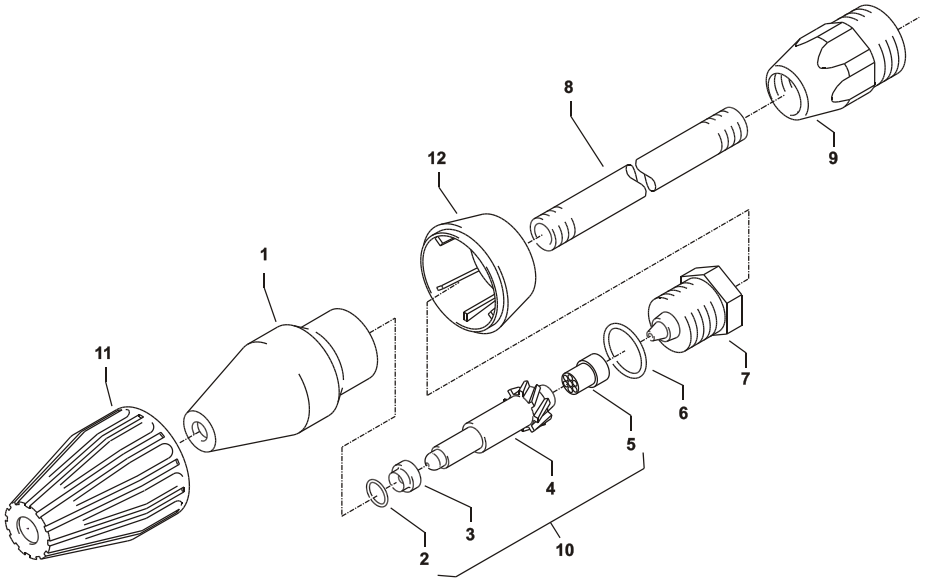

No	Description	Qty.	Ord-No
1	Sprühkörper	1	41.520
2	O-Ring 6,88 x 1,68	1	41.521
3	Düsensitz	1	41.522
4	Düse 035 (quadro 599)	1	41.523 1
4.1	Düse 045 (quadro 799)	1	41.523
4.1	Düse 06 (quadro 899)	1	41.523 5
5	Stabilisator	1	41.524
6	O-Ring	1	40.016 1
7	Sprühstopfen R1/4" IG	1	41.526 1
8	Rohr 600 mm lang; bds. R1/4"	1	12.385 2
9	Nippel M22x1,5 x R1/4" IG	1	13.370
11	Kappe vorn für Schmutzkiller	1	41.528 1
12	Kappe hinten für Schmutzkiller 035	1	41.540 4
12.1	Kappe hinten für Schmutzkiller 045	1	41.540 2
12.2	Kappe hinten für Schmutzkiller 06	1	41.542 2

**Rep.-Satz Schmutzkiller 035** **41.097 0**

**Rep.-Satz Schmutzkiller 045** **41.096 5**

**Rep.-Satz Schmutzkiller 06** **41.096 2**

bestehend aus je 1x 2; 3; 4; 5

**Schmutzkiller 035 mit Lanze 600mm** **46.150**

**Schmutzkiller 045 mit Lanze 600mm** **46.150 1**

**Schmutzkiller 06 mit Lanze 600mm** **46.150 2**

# Wiring diagram

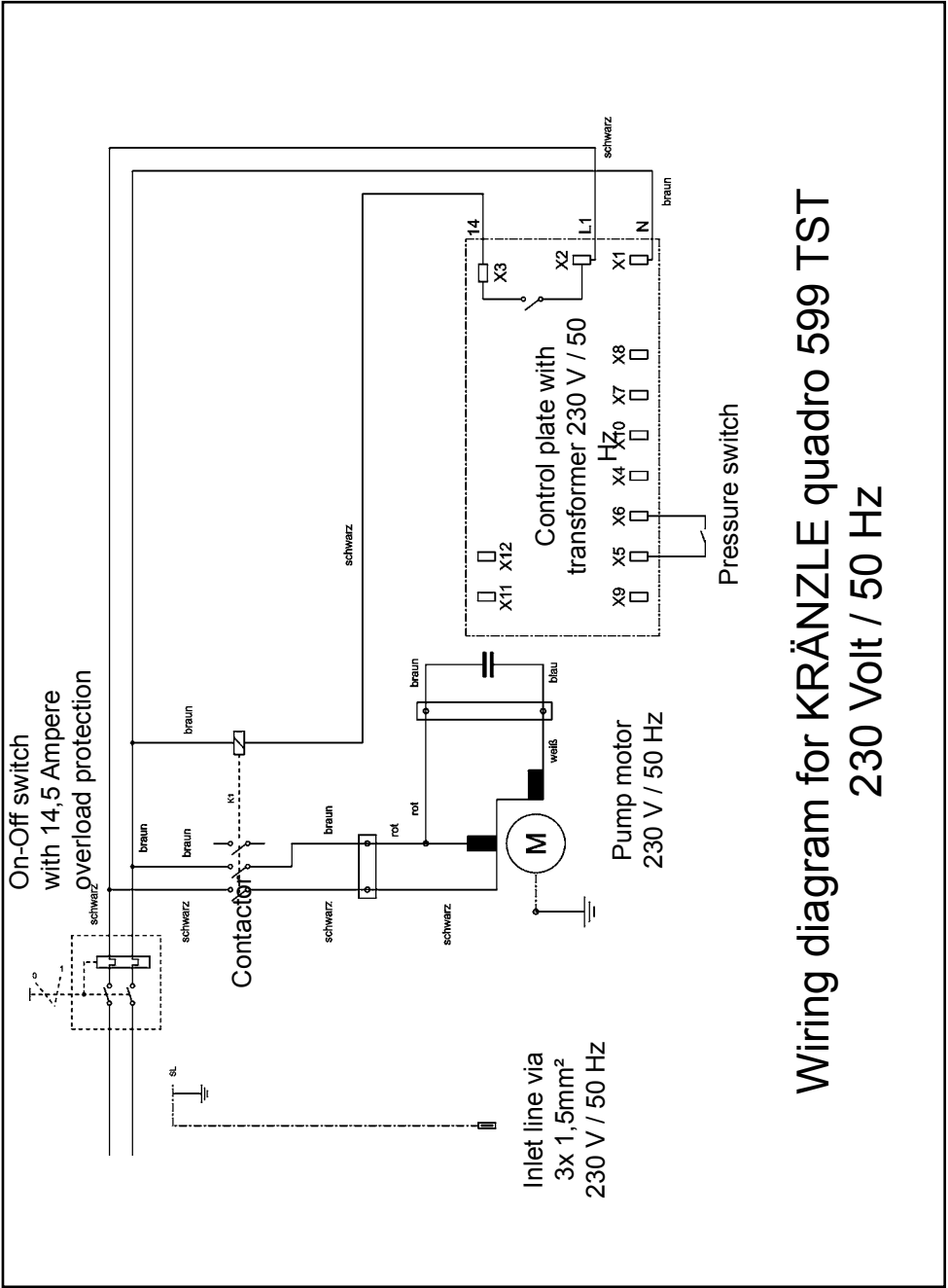

**Wiring diagram for KRÄNZLE quadro 599 TST  
230 Volt / 50 Hz**

# Wiring diagram

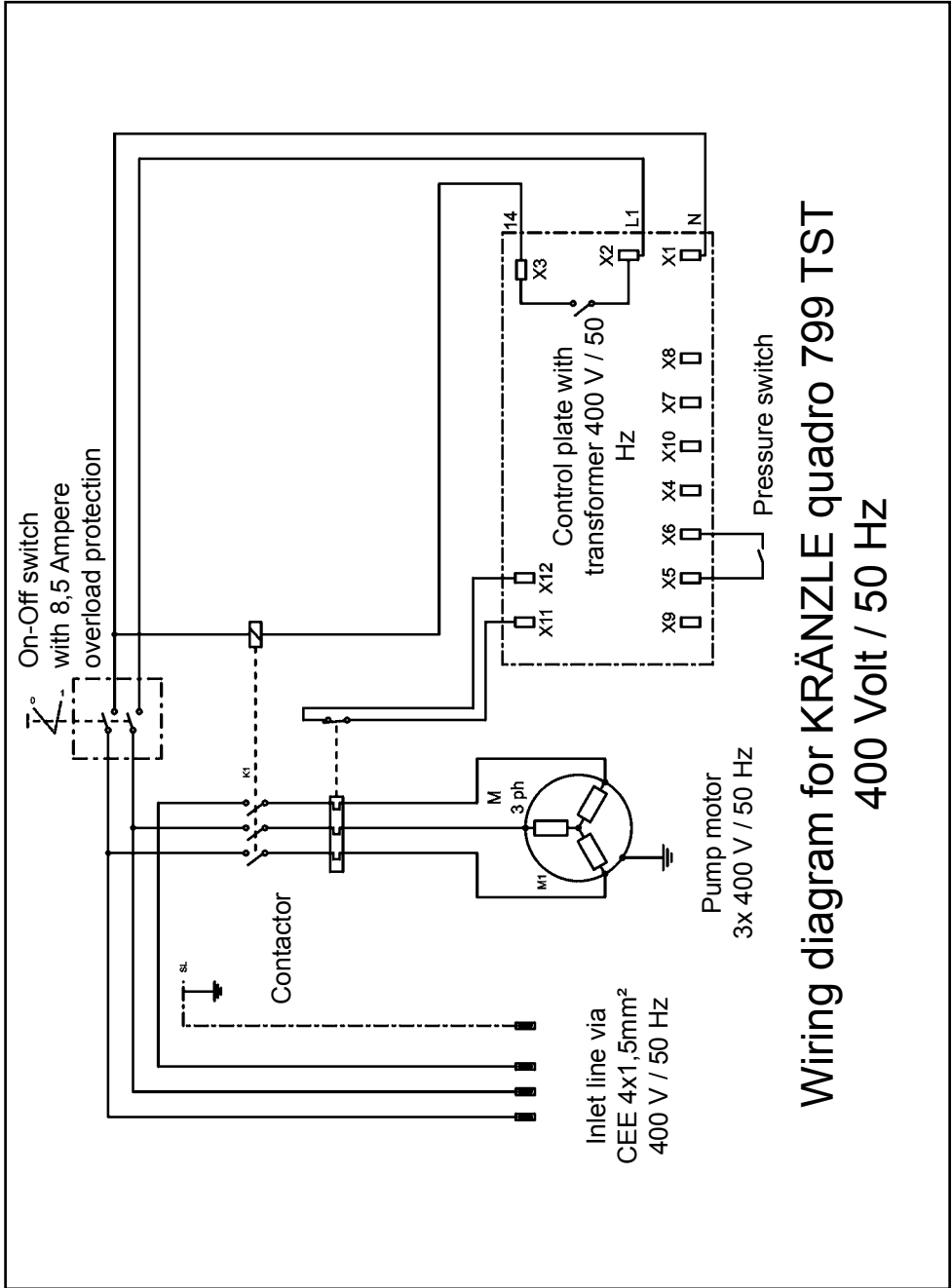

Wiring diagram for KRÄNZLE quadro 799 TST  
400 Volt / 50 Hz

# General rules

## Inspections

The machine must be inspected according to the “Guidelines for Liquid Spray Devices” at least once every 12 months by a qualified person, to ensure that continued safe operation is guaranteed.

The results of the inspection are to be recorded in writing.

This may be done in any form. (see pages 46-47)

## Accident prevention

The machine is designed for accidents to be impossible if used correctly.

The operator is to be notified of the risk of injury from hot machine parts and the high pressure water jet. The “Guidelines for Liquid Spray Devices” must be complied with. (see pages 15 - 17).

**Check the oil level at the oil dip stick prior to each use (see also page 11).  
(Ensure horizontal position!)**

### Oil change:

The first oil change should be carried out after approximately 50 operating hours, then every year or after 1000 operating hours. If the oil turns grey or white, you must change the oil of your high pressure pump in any case. Open the oil discharge screw at the bottom of the device over a collection reservoir. Ensure a horizontal position to drain the oil completely. The oil is to be caught in the reservoir and disposed of in an approved manner.

New oil: 0,8 l

Motor oil: Castrol 10 W-60 SAE halvesynthetic oil



Oil discharge screw

# kränzle®

**Hochdruckreiniger**  
High-pressure-cleaners  
Nettoyeurs À Haute Pression

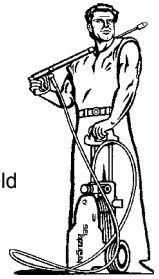

I. Kränzle GmbH  
Elpke 97 . 33605 Bielefeld

## **EC declaration of conformity**

We hereby declare,  
that the high-pressure models:

**Kränzle quadro 599 - 899 TST**

(techn. documentation available from):

**Manfred Bauer, Fa. Josef Kränzle  
Rudolf-Diesel-Str. 20, 89257 Illertissen**

Nominal flow:

**K quadro 599 TST: 600 l/h  
K quadro 799 TST: 780 l/h  
K quadro 899 TST: 900 l/h**

comply with the following guidelines  
and specifications and their amend-  
ments for high-pressure cleaners:

**Machine guideline 2006/42/EEC  
Specification for electromagnetic  
compatibility 2004/108/EEC  
Outdoor noise directive 2005/88/EC,  
Art. 13, High-pressure water jet machines  
Appendix 3, part B, chapter 27**

Sound power level measured:  
guaranteed:

**86 dB (A)  
88 dB (A)**

Applied conformity evaluation  
procedures:

**annex V, noise directive 2005/88/EC**

Applied specifications and  
standards:

**EN 60 335-2-79 :2009  
EN 55 014-1 :2006  
EN 55 014-2 / A2:2008  
EN 61 000-3-2 :2006  
EN 61 000-3-3 :2008**

Bielefeld, den 12.19.2012

A handwritten signature in black ink, appearing to read 'Josef Kränzle', written over a horizontal line.

Kränzle Josef  
(Managing Director)

# Inspection report for HP cleaners

HP cleaners for industrial use have to be checked by an expert every 12 months! Inspection report on annually carried out Labour Safety Inspection (UVV) according to the Guidelines for Liquid Spray Equipment. (This inspection sheet serves as proof for the completion of the retest and must be kept carefully!) Kränzle test seals: Order no. UVV200106

Owner: ..... Type:.....  
 Address: ..... Serial no.: .....  
 ..... Rep. order no.: .....

Scope of inspection	o.k.	yes	no	repaired
Type plate (on hand)				
Operating manual (on hand)				
Protective covering, -device				
Pressure line (tightness)				
Pressure gauge (function)				
Float valve (tightness)				
Spraying device (marking)				
HP-hose / connector (damage, marking)				
Safety valve opens at 10 % / 20 % exceeding of operating pr.				
Power cable (damage)				
Protective conductor (connected)				
On / Off switch				
Used chemicals				
Allowed chemicals				

Inspection data	determined value	set value
High-prsure nozzle		
Operating pressure.....bar		
Switch off pressure.....bar		
Conductor reist. not exceeded / value		
Insulation		
Leakage current		
Gun locked		

## Inspection result (tick)

The appliance was checked by an expert according to the Guidelines for Liquid Spray Equipment, the defects found have been rectified so that the Labour Safety can be confirmed.

The appliance was checked by an expert according to the Guidelines for Liquid Spray Equipment. The Labour Safety cannot be confirmed unless the defects found are rectified by repair or replacement of the faulty parts

The next retest according to the Guidelines for Liquid Spray Equipment has to be carried out by: Month ..... Year .....

Place, date ..... Signature .....

# *Inspection report for HP cleaners*

HP cleaners for industrial use have to be checked by an expert every 12 months! Inspection report on annually carried out Labour Safety Inspection (UVV) according to the Guidelines for Liquid Spray Equipment. (This inspection sheet serves as proof for the completion of the retest and must be kept carefully!) Kränzle test seals: Order no. UVV200106

Owner: ..... Type: .....  
 Address: ..... Serial no.: .....  
 ..... Rep. order no.: .....

Scope of inspection	o.k.	yes	no	repaired
Type plate (on hand)				
Operating manual (on hand)				
Protective covering, -device				
Pressure line (tightness)				
Pressure gauge (function)				
Float valve (tightness)				
Spraying device (marking)				
HP-hose / connector (damage, marking)				
Safety valve opens at 10 % / 20 % exceeding of operating pr.				
Power cable (damage)				
Protective conductor (connected)				
On / Off switch				
Used chemicals				
Allowed chemicals				

Inspection data	determined value	set value
High-prsure nozzle		
Operating pressure.....bar		
Switch off pressure.....bar		
Conductor resist. not exceeded / value		
Insulation		
Leakage current		
Gun locked		

### Inspection result (tick)

The appliance was checked by an expert according to the Guidelines for Liquid Spray Equipment, the defects found have been rectified so that the Labour Safety can be confirmed.

The appliance was checked by an expert according to the Guidelines for Liquid Spray Equipment. The Labour Safety cannot be confirmed unless the defects found are rectified by repair or replacement of the faulty parts

The next retest according to the Guidelines for Liquid Spray Equipment has to be carried out by: Month .....Year .....

Place, date ..... Signature .....

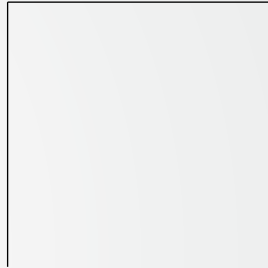

**Ingrid Kränzle GmbH**

Elpke 97

33605 Bielefeld (Germany)

Telefon: +49 (0) 521 / 9 26 26-0

Telefax: +49 (0) 521 / 9 26 26-40

[info@kraenzle.com](mailto:info@kraenzle.com)

As date of 10.09.2014, Order no. 30.600 1  
Subject to technical modifications.

■ **Made**  
■ **in**  
■ **Germany**