

FURRION

1.7 cu. ft. OTR CONVECTION
MICROWAVE OVEN

FMCM17

FMCM17-BL



FMCM17-SS



FMCM17-SB



1000W

POWER



CAPACITY



DEFROST
BY WEIGHT



QUICK DEFROST

9

PRE-SET MENUS



10 POWER
SETTINGS



TURNTABLE

- Three convenient defrost settings
- Available in black, stainless steel and black stainless steel
- Ten pre-set cooking menus: Reheat, cakes, potato, meat, popcorn, beverage, veggies, chicken, melt/soften, keep warm



FMCM17 | 1.7 cu. ft. OTR CONVECTION MICROWAVE OVEN

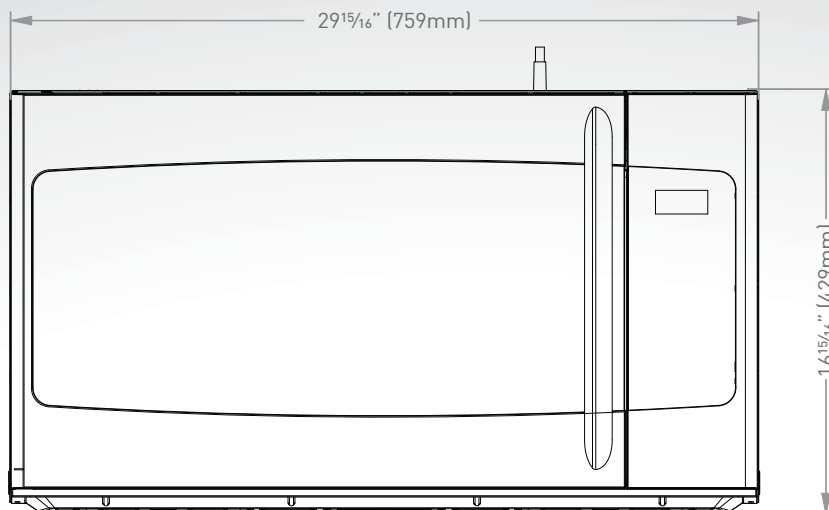

Specifications

Power	1000W
Power Levels	10
Convection Input Power	1350W
Grill Input Power	1050W
Express Cook	1 to 6 minutes
Ventilation System	300 CMF
ECO Mode	✓
Quick Start	✓
Kitchen Timer	✓
Turntable	✓
Handle Door	✓

Dimensions

Product Size (W x H x D)	29 ¹⁵ / ₁₆ " x 16 ¹⁵ / ₁₆ " x 17 ¹⁵ / ₁₆ " (759 x 429 x 455mm)
--------------------------	---

Packaging Information

Packaging Type	Brown Box
Quantity Per Box (pcs)	1
Individual Packaging Dimensions (W x H x D)	33 ¹ / ₂ " x 20 ¹ / ₂ " x 19 ¹ / ₂ " (850 x 520 x 495mm)
Individual Packaging Gross Weight (kg/lbs)	34.6/76.1
Individual Packaging Net Weight (kg/lbs)	31/69.5

Container Load Information

40' HQ Container Load (pcs)	329
-----------------------------	-----

* Note: "✓"=Equipped