

# FURRION

## ALL-IN-ONE POWER CENTER

FCVSWC42A



OVER VOLTAGE  
PROTECTION



OVER CURRENT  
PROTECTION



SHORT CIRCUIT  
PROTECTION



THERMAL  
PROTECTION

UP TO  
**420W**

CONVERTER/CHARGER  
RATING



LEAD ACID  
BATTERY CHARGING



WORK WITH FURRION  
LIFEPO4 BATTERY



BATTERY  
MAINTENANCE-FREE



INTELLIGENT  
FAN SPEED CONTROL

- Easy access reverse battery protection fuses

- Reverse Polarity Protection (fused)



# FCVSWC42A | ALL-IN-ONE POWER CENTER

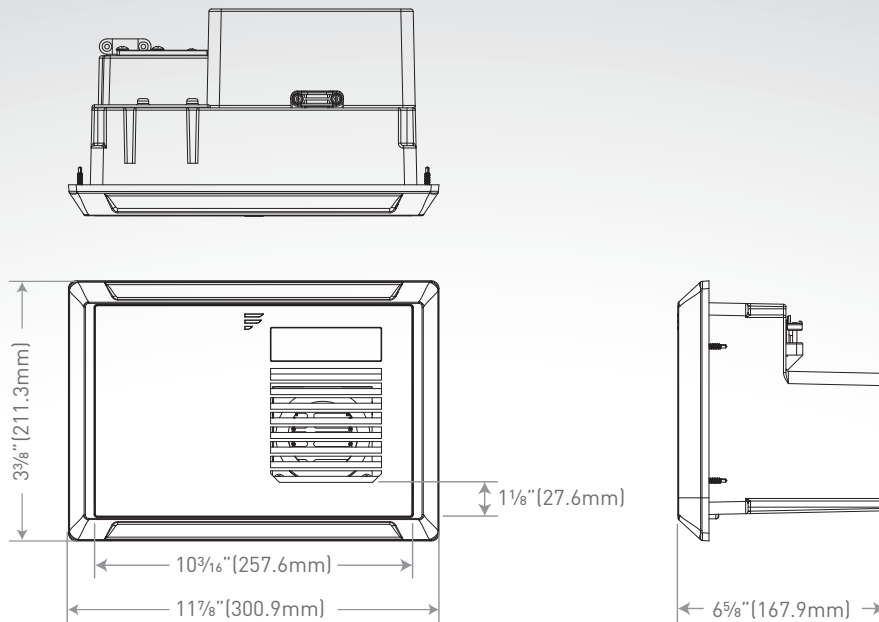

## Specifications

<b>LiFePo4</b>	
Bulk	14.6 V
Float	13.6V
<b>Sealed</b>	
Bulk	14.4V
Float	13.4V
Stand By Voltage	13.2V
Charge Current	35A
Operation Voltage Range	105Vac to 132Vac / 60Hz
Full Load Input Power	615W
No Load Input Current	250mA
Full Load Input Current (120V/60Hz)	7A
Efficiency (at LiFePo4)(120Vac)	>80%
Line Regulation At Full Load (@input voltage 105V to 132V)	3%
Output Over Voltage Protection	√
Load Regulation (10%-100% Load)	3%
Auto Battery Type Selection	√
Certification	UL458/UL67/FCC PART 15b
Working Environment	-10°C to 50°C/14°F to 122°F
Storage Environment	-20°C to 70°C/-4°F to 158°F

## Protection

Reverse Polarity Protection	By Fuse
Electronic Current Limiting	√
Intelligent Fan Speed Control	√
Intelligent Thermal De-rating & Cut-off Protection	√
DC Lower & Higher Voltage Protection	√
AC Lower Voltage Protection	√

## Packaging Information

Packaging Type	Master Carton Box
Quantity Per Box (pcs)	2
Master Carton Dimensions (W x H x D)	15 3/4" x 15 3/4" x 15 3/16" (400 x 400 x 385mm)
Master Carton Gross Weight (kg/lbs)	
Master Carton Net Weight (kg/lbs)	

## Container Load Information

40" HQ Container Load (pcs)	1800
-----------------------------	------

\* Note: "√"=Equipped