

# FURRION NET-ZERO

60A CONVERTER

FCVSDC60A

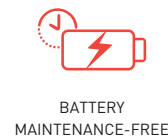
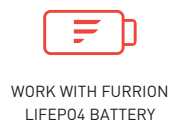

- Easy access to DC protection fuses
- Float and Standby mode for auto-recycle charge to keep battery fresh, even during long periods of inactivity

- Reverse Polarity Protection (Fused)
- The Micro-Processor Control allows auto charging operations to ensure a quick and full battery charge



# FCVSDC60A | 60A CONVERTER

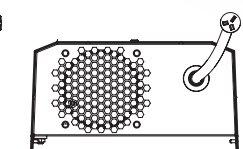
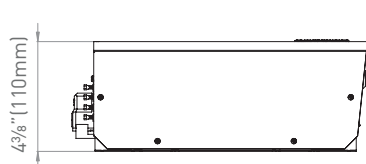
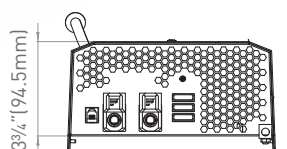
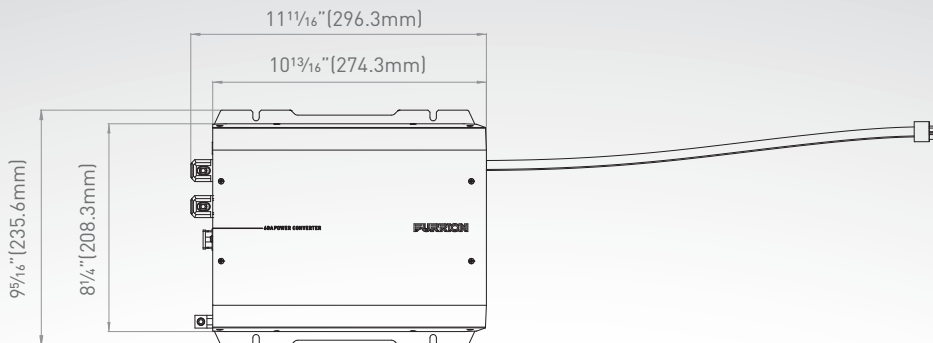

## Specifications

<b>LiFePo4</b>	
Bulk	14.6 V
Float	13.6V
<b>Sealed</b>	
Bulk	14.4V
Float	13.4V
Stand By Voltage	13.2V
Charge Current	60A
Operation Voltage Range	100Vac to 132Vac / 60Hz
Output Over Current Protection	65A
Full Load Input Power	1015W
No Load Input Current	300mA
Full Load Input Current (120V/60Hz)	9A
Efficiency (at LiFePo4)(120Vac)	>80%
Line Regulation At Full Load (input voltage 105V to 132V)	3%
Output Over Voltage Protection	✓
Load Regulation (10%-100% Load)	3%
Ripple & Noise (r.m.s)	30mV
Rj11 For Battery Type Selection Standard	✓
Working Environment	UL458
Storage Environment	-10°C to 50°C/14°F to 122°F (Higher than 50C will be de-rating) -20°C to 80°C/-4°F to 176°F

## Protection

Reverse Polarity Protection	By Fuse
Electronic Current Limiting	✓
Intelligent Fan Speed Control	✓
Intelligent Thermal De-rating & Cut-off Protection	✓
DC Lower & Higher Voltage Protection	✓

## Packaging Information

Packaging Type	Brown Box
Quantity Per Box 1 (pcs)	1pcs
Individual Packaging Dimensions (W x H x D)	13 9/16" x 5 1/16" x 10 7/16" (345 x 145 x 265 mm)
Individual Packaging Gross Weight (kg/lbs)	4kg/8.8lbs
Individual Packaging Net Weight (kg/lbs)	3kg/6.6lbs

## Master Carton

Packaging Type	Master Carton Box
Quantity Per Box (pcs)	4 pcs
Master Carton Dimensions (W x H x D)	21 5/16" x 12" x 14 1/16" (542 x 305 x 357 mm)
Master Carton Gross Weight (kg/lbs)	15kg/33.1lbs
Master Carton Net Weight (kg/lbs)	14kg/30.9lbs

\* Note: "✓"=Equipped