

THE POWER OF  
**REDARC**<sup>®</sup>

# BMS Load Disconnect Isolator

**SBI12-BLD**

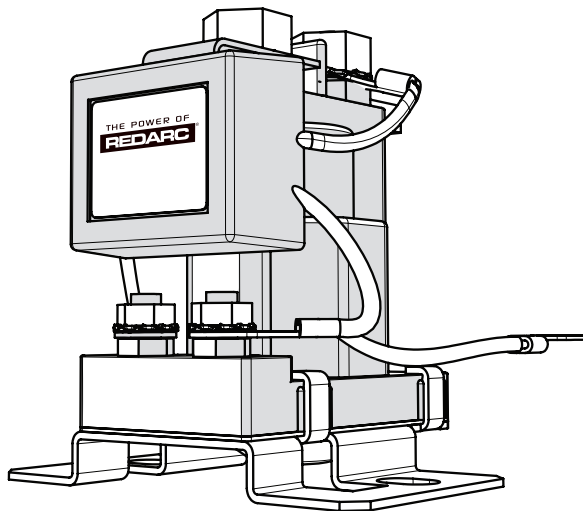

# WARNING & SAFETY INSTRUCTIONS

---

**SAVE THESE INSTRUCTIONS - This manual contains IMPORTANT SAFETY INSTRUCTIONS for the SBI12-BLD battery isolator.**

**DO NOT OPERATE THE ISOLATOR UNLESS YOU HAVE READ AND UNDERSTOOD THIS MANUAL AND THE ISOLATOR IS INSTALLED AS PER THESE INSTALLATION INSTRUCTIONS.**

## **⚠ WARNING**

**RISK OF EXPLOSIVE GASES:**

**WORKING IN VICINITY OF A LEAD-ACID BATTERY IS DANGEROUS. BATTERIES GENERATE EXPLOSIVE GASES DURING NORMAL OPERATION. FOR THIS REASON, IT IS OF UTMOST IMPORTANCE THAT YOU FOLLOW THE INSTRUCTIONS EACH TIME YOU USE THE CHARGER.**

## **⚠ CAUTION**

1. NEVER smoke or allow a spark or flame in vicinity of battery or engine. This may cause the battery to explode.
2. Be extra cautious so as to reduce the risk of dropping a metal tool onto a vehicle battery. Doing so might cause the battery to spark or might short-circuit the battery or other electrical parts that may cause an explosion.
3. Remove personal metal items such as rings, bracelets, necklaces, and watches when working with a lead-acid battery. A lead-acid battery can produce a short-circuit current high enough to weld a ring or the like to metal, causing a severe burn.
4. A spark near a battery may cause the battery to explode. To reduce the risk of a spark near a battery when connecting the battery installed in a vehicle to the isolator, always do the following:
  - a) Position DC cords to reduce the risk of damage by the vehicle hood, door, or moving engine part.
  - b) Stay clear of fan blades, belts, pulleys and other parts that can cause injury to persons.
  - c) Determine which post of the battery is grounded (connected) to the chassis. If the negative post is grounded to the chassis (as in most vehicles), see (e). If the positive the post is grounded to the chassis see (f).
  - d) For use in negative-grounded vehicles only. Connect the POSITIVE (RED) terminals from the Battery Isolator to the POSITIVE (POS, P, +) of the auxiliary battery. Connect the NEGATIVE (BLACK) lead to a metal part of the frame or the vehicle chassis, away from the battery. Do not connect the connect to the carburettor or fuel lines.
5. Personal safety precautions to assist with safely working with Batteries:
  - a) Consider having someone close by to come to your aid when you are working with the Battery.
  - b) Have plenty of fresh water and soap nearby in case battery acid contacts skin, clothing, or eyes.
  - c) Wear complete eye protection and clothing protection. Avoid touching eyes while working near a battery.
  - d) If battery acid contacts your skin or clothing, remove the affected clothing and wash the affected area of your skin immediately with soap and water. If battery acid enters your eye, immediately flood the eye with running cold water for at least 10 minutes and seek medical assistance immediately.

## **NOTICE**

1. Over discharge risk. Ensure that the Turn OFF voltage is suitable for the specifications provided by the battery manufacturer.
2. The SBI12-BLD is designed for controlling loads from an Auxiliary battery. Using the SBI12-BLD to isolate from a start battery will result in a state of charge too low to start the vehicle.

## WARNING & SAFETY INSTRUCTIONS

---

3. The SBI12-BLD will achieve best results when proper battery maintenance is regularly performed. This includes but is not limited to checking water and specific gravity levels of the battery. Refer to the battery manufacturers manual for more details.
4. Fuses or Circuit breakers of appropriate rating must be installed to protect the vehicle system.
5. Fuses must be installed as close as possible to the battery.
6. **IMPORTANT!** Do NOT make any connections to the control terminals found on the front of the unit. Ensure that connections are not accidentally bridged between terminals whilst tightening. Connecting to the control terminals on the front of the SBI may cause damage to the unit and/or equipment connected to it. Connecting to the control terminals will void the warranty of the unit.

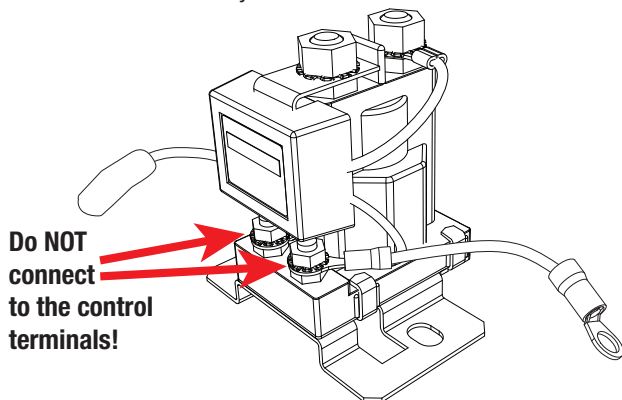

## SPECIFICATIONS

---

System Voltage	12V Nominal
Turn ON Voltage	10.2V
Turn OFF Voltage	10.0V
Turn ON Delay	5 sec
Turn OFF Delay	10 sec
Instant OFF Voltage	9.0V
Max. Cont. Current	100 Amps
Max. Inrush Current	400 Amps
Standby Current	< 5mA
Operating Current	<0.1A
Dimensions	75 x 70 x 80mm
Weight	200g
Warranty	2 years
Standards	CE, C-Tick, AS/NZS CISPR11:2004
Main Stud Torque	5-6.2 Nm

## RECOMMENDED FUSES & CABLING

---

The SBI12-BLD is used in conjunction with a Redarc *Manager15* or *Manager30* battery management system in a 12V negative ground automotive system to protect the auxiliary battery from excessive discharge. Specifically designed for use as the load disconnect solenoid controlled by the BMS, the black (earth wire) should be connected to the load pin of the BMS. The BMS sets the turn on and turn off points through its settings and switches this black wire (earth when loads should be on, no earth when loads should be off), and there is additional voltage thresholds monitored by the SBI12-BLD to ensure reliable solenoid engagement. The Isolator monitors the auxiliary battery and when this drops below the Turn OFF voltage, the solenoid will open, disconnecting the load. The solenoid will close again when the auxiliary battery voltage reaches the Turn ON Voltage. A Delay Time is built into the unit for each transition to reduce the chance of chattering.

The voltage must remain at or above the Turn ON Voltage for a Delay Time ON period before the solenoid closes. Similarly the voltage must remain at or below the Turn OFF Voltage for a Delay Time OFF period before the solenoid opens.

## RECOMMENDED FUSES & CABLING

---

Suitably sized Wire and fuses for the connected loads should be used. REDARC recommend using MIDI fuses along with a quality fuse holder to match. The diagram below shows the construction of a MIDI fuse installation (cables not included).

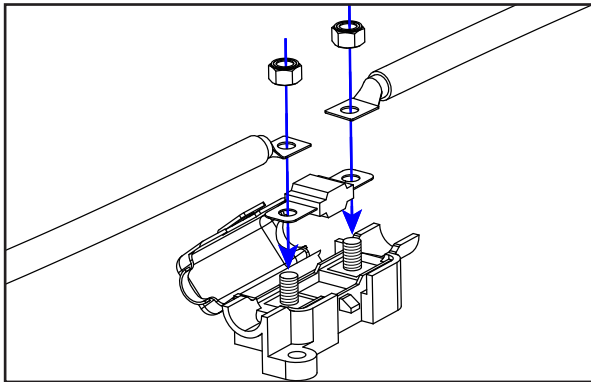

REDARC offer MIDI fuse kits containing the required fuses, fuse holders, crimps and nuts:

Part numbers	
FK40	40A Fuse Kit
FK60	60A Fuse Kit
FK100	100A Fuse kit

## INSTALLATION INSTRUCTIONS

---

1. Mount the SBI12-BLD securely in a convenient location near the auxiliary battery bank. Do not mount in direct engine heat.
2. Install in the order described below:
  - Ground Connection. Connect the SBI12-BLD ground terminal to the BMS Load Disconnect terminal. Note: A good connection will ensure correct switching voltage.
  - Select correct Circuit Breaker/Fuse sizes and install at battery end of the positive cable
  - **LED Connections (optional)**. Connect a wire from the Blue wire of the SBI12-BLD to the positive end of an indicator LED (15mA limited current draw) or LED/resistor combination.
  - **Install and operate in conjunction with the BMS User manual.**

### **⚠ CAUTION**

**Over discharge risk. Ensure that the Turn OFF levels set on the BMS are suitable for the specifications provided by the battery manufacturer.**

### **NOTICE**

**As per above, it is normal for the LED to stay ON whenever the auxiliary battery is in a condition suitable for running loads.**

# STANDARD WIRING DIAGRAMS

- Ensure adequately sized cable is used.
- Ensure the loads are properly grounded to a common chassis earth point.
- Ensure the SBI12-BLD ground wire is wired to the load Disconnect terminal of the BMS.
- When using fuses make sure that the fuse makes a good low resistance connection.
- Fuse/Circuit Breaker ratings are dependent on the type of installation and the size of the loads.

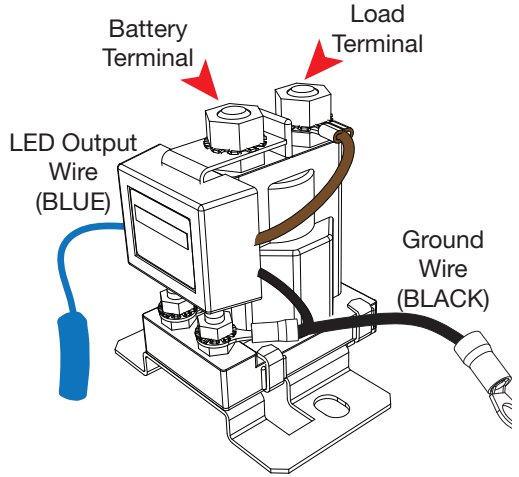

\* The size of this fuse relates to the total current draw of all the loads connected to the House Battery, and should be rated slightly higher than this.

\*\* Essential loads are loads which must be left on at all times, until the battery is flat. Non-essential loads are those switched off when the battery reaches a particular low-charge level, which can be set in the 'Advanced Settings' menu.

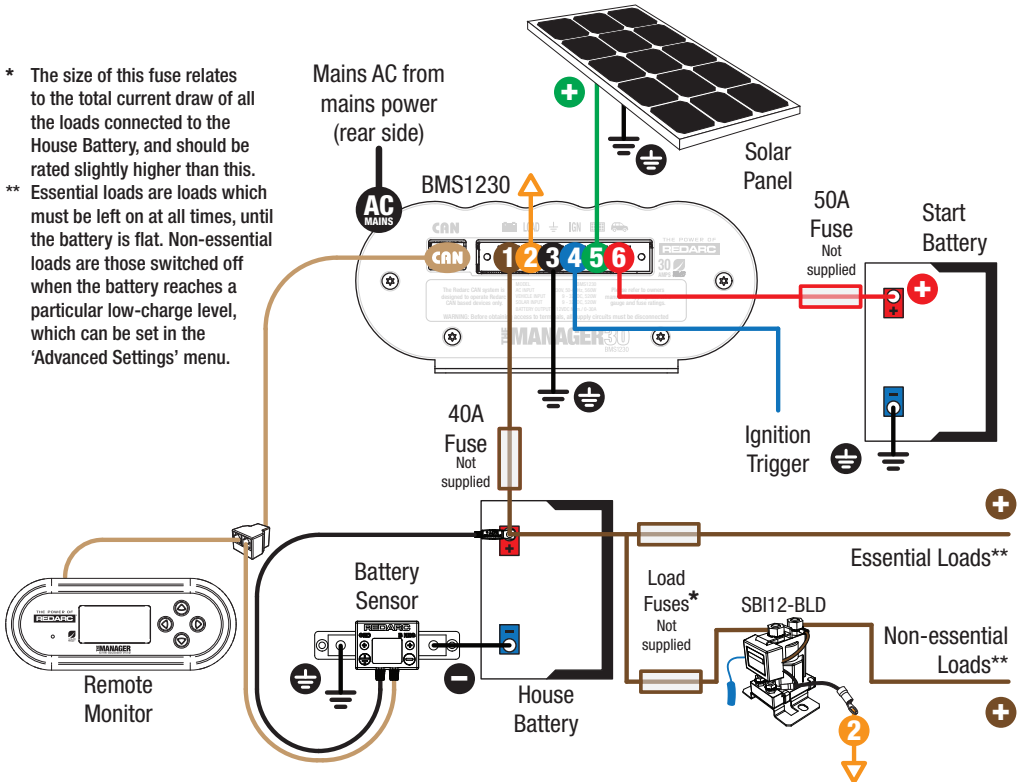

## FAULT INDICATION

---

**NOTE: The LED will be on when the SBI12-BLD is active (on).**

Should a fault occur, the SBI12-BLD is set to notify the operator of the fault. The LED will flash repeatedly with the following sequences:

CODE 1	2 Flashes	Over-Voltage
CODE 2	3 Flashes	Voltage Drop or Excessive Current Draw Fault

### **FAULT CODE 1: 2 Flashes (Over-Voltage Detection)**

If the battery connected to the SBI12-BLD should rise above 15.5 Volts the Smart Start® will:

- Disconnect, to prevent the source of over-voltage reaching the load
- Flash the LED 2 times for 20 seconds, then reassess the fault condition, continuing until the fault is cleared.

### **FAULT CODE 2: 3 Flashes (Voltage Drop / Excessive Current Draw)**

If the SBI12-BLD detects a voltage drop across its contacts of greater than 1 Volt for more than ½ second then the unit will:

- Immediately protect itself and the load by disconnecting the load; and
- Flash the LED 3 times for 20 seconds, then reassess the presence of a fault, continuing until the fault is cleared.

## FREQUENTLY ASKED QUESTIONS

---

**Question:** Is the unit protected against voltage spikes?

**Answer:** Yes, the SBI12-BLD incorporates a number of spike protection components specifically designed to reduce the risk of damaging the unit. The SBI12-BLD is also designed to prevent any spikes generated by the solenoid coil from affecting any vehicle equipment.

**Question:** What does the red LED indicate?

**Answer:** The red LED indicates the solenoid is activated and therefore the battery is supplying power to the load. A flashing red LED during operation indicates a fault. See **Fault Indication** on page 6.

**Question:** Can the voltage limits and time delay settings be changed?

**Answer:** Yes! Both upper and lower voltage limits & on and off times can be changed. However, this needs to be done at the time of manufacture and will incur a cost.

**Question:** We are experiencing repetitive switching of our SBI12-BLD. What could be causing this?

**Answer:** This can occur for one of two reasons. Firstly, switching an excessively large load which would drop the battery to below its lower voltage limit and causing the SBI12-BLD to turn off. After turning off the load, the battery would recover in voltage; If the battery voltage climbs higher than the turn on threshold, the SBI12-BLD would turn the loads back on.

Secondly, voltage drop due to cable length (ie the SBI12-BLD being mounted too far from Auxiliary battery) can cause the voltage at the battery terminal on the SBI12-BLD to be lower than at the auxiliary battery, which can also cause the unit to switch off. Voltage seen by the SBI12-BLD will now rise again until the SBI12-BLD switches back on. This switching will continue until the cause of voltage drop is removed. On and Off Time delays are built into the product to avoid the solenoid contacts chattering in this scenario.

**Question:** Can I use the SBI12-BLD on a positive chassis vehicle?

**Answer:** Yes. Please contact REDARC for further information.



# TWO YEAR PRODUCT WARRANTY

Over the last three decades our company has established a reputation as the power conversion specialist.

A 100% Australian-owned company, we have met the needs of customers in transport and other industries through exciting, innovative thinking.

We believe in total customer satisfaction and practice this by offering our customers:

- Technical advice free of jargon and free of charge
- Prompt turnaround of orders throughout Australia and globally
- Friendly, personalised, professional service and product support

In the unlikely event that a technical issue arises with a Redarc product, customers are encouraged to initially contact the Redarc Technical Support Team on (08) 8322 4848 or [power@redarc.com.au](mailto:power@redarc.com.au) for prompt and efficient diagnosis and product support.

Our goods come with guarantees that cannot be excluded under the Australian Consumer Law. You are entitled to a replacement or refund for a major failure and compensation for any other reasonably foreseeable loss or damage. You are also entitled to have the goods repaired or replaced if the goods fail to be of acceptable quality and the failure does not amount to a major failure.

The benefits of this Warranty are in addition to other rights and remedies available at law in respect of the Products and shall not derogate from any applicable mandatory statutory provisions or rights under the Australian Consumer Law.

Redarc Electronics Pty Ltd aff the Redarc Trust trading as Redarc Electronics ("Redarc") offers a warranty in respect of its Products where the Products are purchased from an authorised distributor or reseller of Redarc by a person ("Purchaser"), on the terms and conditions, and for the duration, outlined below in this document ("Warranty").

1. In this Warranty, the term **Products** means:

- 1.1 all products manufactured or supplied by Redarc (excluding its solar products which are covered by Redarc's Solar Product Warranty); and
- 1.2 any component of or accessory for any product in clause 1.1 manufactured or supplied by Redarc.

**Offer and duration of product warranties**

2. Redarc warrants that its Products will be free, under normal application, installation, use and service conditions, from defects in materials and workmanship affecting normal use, for **2 years** from the date of purchase (**Warranty Period**).
3. Where a Product malfunctions or becomes inoperative during the Warranty Period, due to a defect in materials or workmanship, as determined by Redarc, then subject to further rights conferred by the Australian Consumer Law on the Purchaser, Redarc will, in exercise of its sole discretion, either:
  - 3.1 repair the defective Product;
  - 3.2 replace the defective Product; or
  - 3.3 provide a refund to the Purchaser for the purchase price paid for the defective Product, without charge to the Purchaser.
4. The warranty given by Redarc in clause 3 covers the reasonable costs of delivery and installation of any repaired or replaced Products or components of Products to the Purchaser's usual residential address notified to Redarc, together with the reasonable costs of removal and return of any Products determined by Redarc to be defective.
5. If the Purchaser incurs expenses of the nature referred to in clause 4 in the context of making a claim pursuant to this Warranty that is accepted by Redarc, the Purchaser will be entitled to claim for reimbursement of those expenses which Redarc determines, in exercise of its sole discretion, to be reasonably incurred, provided that the claim is notified to Redarc in writing at the postal address or email address specified in clause 21 and includes:
  - 5.1 details of the relevant expenses incurred by the Purchaser; and
  - 5.2 proof of the relevant expenses having been incurred by the Purchaser.

**Exclusions and limitations**

6. This Warranty will not apply to, or include any defect, damage, fault, failure or malfunction of a Product, which Redarc determines, in exercise of its sole discretion, to be due to:
  - 6.1 normal wear and tear or exposure to weather conditions over time;
  - 6.2 accident, misuse, abuse, negligence, vandalism, alteration or modification;
  - 6.3 non-observance of any of the instructions supplied by Redarc, including instructions concerning installation, configuring, connecting, commissioning, use or application of the Product, including without limitation choice of location;
  - 6.4 failure to ensure proper maintenance of the Product strictly in accordance with Redarc's instructions or failure to ensure proper maintenance of any associated equipment or machinery;
  - 6.5 repairs to the Product that are not strictly in accordance with Redarc's instructions;
  - 6.6 installation, repairs or maintenance of the Product by, or under the supervision of, a person who is not a qualified auto electrician or technician, or if non-genuine or non-approved parts have been fitted;
  - 6.7 faulty power supply, power failure, electrical spikes or surges, lightning, flood, storm, hail, extreme heat, fire or other occurrence outside the control of Redarc;
  - 6.8 use other than for any reasonable purpose for which the Product was manufactured;
  - 6.9 any indirect or incidental damage of whatever nature outside the control of Redarc.
7. Warranty claims in respect of a Product must be made in writing to Redarc at the postal address or email address specified in clause 21 within the Warranty Period. Such claims must include the following:
  - 7.1 details of the alleged defect or fault and the circumstances surrounding the defect or fault;
  - 7.2 evidence of the claim, including photographs of the Product (where the subject of the claim is capable of being photographed);
  - 7.3 the serial number of the Product, specified on the label affixed to the Product; and
  - 7.4 proof of purchase documentation for the Product from an authorised distributor or reseller of Redarc, which clearly shows the date and place of purchase.The return of any Products without the prior written instructions of Redarc will not be accepted by Redarc.

8. Without limiting any other clause in this Warranty, Redarc has the right to reject any Warranty claim made by a Purchaser pursuant to this Warranty where:

- 8.1 the Purchaser does not notify Redarc in writing of a Warranty claim within the Warranty Period;
- 8.2 the Purchaser does not notify Redarc in writing of a Warranty claim within 1 month of becoming aware of the relevant circumstances giving rise to the claim, so that any further problems with the Product are minimised;
- 8.3 the serial number of the Product has been altered, removed or made illegible without the written authority of Redarc;
- 8.4 the Purchaser is unable to provide proof of purchase documentation in accordance with clause 7.4 or evidence that the Product was properly installed and removed (if relevant), and that proper maintenance has been performed on the Product, by, or under the supervision of, a qualified auto electrician or technician, in accordance with the instructions of Redarc.
9. If the Product is found to be working satisfactorily on return to Redarc or upon investigation by Redarc, the Purchaser must pay Redarc's reasonable costs of testing and investigating the Product in addition to shipping and transportation charges. Where Redarc is in possession of the Product, the Product will be returned to the Purchaser on receipt of the amount charged.
10. Any replaced Products or components of Products shall become the property of Redarc.
11. Redarc may, in exercise of its sole discretion, deliver another type of Product or component of a Product (different in size, colour, shape, weight, brand and/or other specifications) in fulfilling its obligations under this Warranty, in the event that Redarc has discontinued manufacturing or supplying the relevant Product or component at the time of the Warranty claim, or where such Product or component is superior to that originally purchased by the Purchaser.

**Other conditions of Warranty**

12. If the Purchaser acquired a Product for the purpose of resupply, then this Warranty shall not apply to that Product.
13. In particular, the sale of a Product via an online auction, online store or other internet website by a party that is not an authorised distributor or reseller of the Product will be deemed to be a resupply within the meaning of the Australian Consumer Law and will render this Warranty void, as Redarc has no control over the storage, handling, quality or safety of Products sold by such persons.
14. A Purchaser shall only be entitled to the benefit of this Warranty after all amounts owing in respect of the Product have been paid.
15. While Redarc warrants that the Products will be free from defects in materials and workmanship in the circumstances set out in this Warranty, to the maximum extent permitted by law Redarc does not warrant that the operation of the Products will be uninterrupted or error-free.
16. To the maximum extent permitted by law, Redarc's determination of the existence of any defect and the cause of any defect will be conclusive.
17. Spare parts or materials for the Products are guaranteed to be available for a period of at least 2 years after purchase of the Products.
18. The agents, officers and employees of any distributor or reseller of the Products and of Redarc are not authorised to vary or extend the terms of this Warranty.
19. Redarc shall not be responsible or liable to the Customer or any third party in connection with any non-performance or delay in performance of any terms and conditions of this Warranty, due to acts of God, war, riots, strikes, warlike conditions, plague or other epidemic, fire, flood, blizzard, hurricane, changes of public policies, terrorism and other events which are beyond the control of Redarc. In such circumstances, Redarc may suspend performance of this Warranty without liability for the period of the delay reasonably attributable to such causes.
20. If a clause or part of a clause in this Warranty can be read in a way that makes it illegal, unenforceable or invalid, but can also be read in a way that makes it legal, enforceable and valid, it must be read in the latter way. If any clause or part of a clause in this Warranty is illegal, unenforceable or invalid, that clause or part is to be treated as removed from this Warranty, but the rest of this Warranty is not affected.

**Redarc's contact details**

21. Redarc's contact details for the sending of Warranty claims under this Warranty are:  
Redarc Electronics Pty Ltd  
23 Brodie Road (North), Lonsdale SA 5160  
Email: [power@redarc.com.au](mailto:power@redarc.com.au)  
Telephone: +61 8 8322 4848

THE POWER OF  
**REDARC**®

**Free technical assistance!**

please contact

REDARC Electronics

23 Brodie Road North, Lonsdale SA

(08) 8322 4848

[power@redarc.com.au](mailto:power@redarc.com.au)

[www.redarc.com.au](http://www.redarc.com.au)

**Mailing Address**

PO Box 469

Morphett Vale

South Australia 5162

Copyright © 2018 REDARC Electronics Pty Ltd. All rights reserved.