

Dell PowerEdge R630

Owner's Manual

Notes, cautions, and warnings

 **NOTE:** A NOTE indicates important information that helps you make better use of your product.

 **CAUTION:** A CAUTION indicates either potential damage to hardware or loss of data and tells you how to avoid the problem.

 **WARNING:** A WARNING indicates a potential for property damage, personal injury, or death.

Chapter 1: Dell PowerEdge R630 system overview.....	8
Supported configurations for PowerEdge R630 system.....	8
Front panel	10
10 x 2.5-inch hard drive chassis.....	10
Eight x 2.5-inch hard drive chassis.....	11
24 x 1.8-inch hard drive chassis.....	13
LCD panel.....	14
Back panel features.....	16
Two-riser chassis.....	16
Three-riser chassis.....	18
Diagnostic indicators on the front panel.....	19
Hard drive indicator codes.....	21
uSATA SSD indicator codes.....	22
NIC indicator codes.....	23
Power supply unit indicator codes.....	23
iDRAC Direct LED indicator codes.....	25
Quick Sync indicator codes.....	27
Locating service tag of your system.....	27
Chapter 2: Documentation resources.....	28
Chapter 3: Technical specifications.....	30
Chassis dimensions.....	30
Chassis weight.....	31
Processor specifications.....	31
PSU specifications.....	31
System battery specifications.....	32
Expansion bus specifications.....	32
Memory specifications.....	32
Drive specifications.....	32
Hard drives.....	32
Optical drive.....	33
Ports and connectors specifications.....	33
USB ports.....	33
NIC ports.....	33
Serial connector.....	33
VGA ports.....	33
Internal Dual SD Module.....	33
Video specifications.....	34
Environmental specifications.....	34
Particulate and gaseous contamination specifications.....	35
Standard operating temperature.....	36
Expanded operating temperature.....	36
Expanded operating temperature restrictions.....	37

Chapter 4: Initial system setup and configuration.....	38
Setting up your system.....	38
iDRAC configuration.....	38
Options to set up iDRAC IP address.....	38
Options to install the operating system.....	39
Methods to download firmware and drivers.....	39
Chapter 5: Pre-operating system management applications.....	41
Options to manage the pre-operating system applications.....	41
System Setup.....	41
Viewing System Setup.....	42
System Setup details.....	42
System BIOS.....	42
iDRAC Settings utility.....	65
Device Settings.....	66
Dell Lifecycle Controller.....	66
Embedded systems management.....	67
Boot Manager.....	67
Viewing Boot Manager.....	67
Boot Manager main menu.....	67
PXE boot.....	68
Chapter 6: Installing and removing system components.....	69
Safety instructions.....	69
Before working inside your system.....	70
After working inside your system.....	70
Recommended tools.....	70
Front bezel (optional).....	71
Removing the optional front bezel.....	71
Installing the optional front bezel.....	72
System cover.....	74
Removing the system cover.....	74
Installing the system cover.....	74
Inside the system.....	75
Cooling shroud.....	78
Removing the cooling shroud.....	78
Installing the cooling shroud.....	78
System memory.....	79
Removing memory modules.....	79
Installing memory modules.....	80
Hard drives.....	82
Removing a 2.5-inch hard drive blank.....	82
Installing a 2.5-inch hard drive blank.....	83
Removing a 1.8-inch hard drive blank.....	83
Installing a 1.8-inch hard drive blank.....	84
Removing a hot swappable hard drive or solid state drive.....	85
Installing a hot swappable hard drive.....	86
Removing a hard drive or a solid state drive from a hard drive carrier.....	88

Installing a hot swappable hard drive into a hot swappable hard drive carrier.....	88
Removing a 1.8-inch hard drive from a hard drive carrier.....	89
Installing a 1.8-inch hard drive into a hard drive carrier.....	89
Optical drive (optional).....	90
Removing the optional optical drive.....	90
Installing the optional optical drive.....	91
Removing the slim optical drive blank.....	92
Installing the slim optical drive blank.....	93
Cooling fans.....	94
Removing a cooling fan.....	94
Installing a cooling fan.....	95
Internal USB memory key (optional).....	95
Replacing the optional internal USB memory key.....	96
Expansion cards and expansion card riser.....	97
Expansion card installation guidelines.....	97
Removing expansion card risers.....	98
Removing an expansion card.....	99
Installing an expansion card.....	100
Installing expansion card risers.....	101
SD vFlash card (optional).....	103
Replacing an SD vFlash card.....	103
IDSDM	103
Removing an internal SD Card.....	104
Installing an internal SD card.....	104
Removing the optional internal dual SD module.....	105
Installing the optional internal dual SD module	106
Integrated storage controller card.....	106
Removing the integrated storage controller card.....	106
Installing the integrated storage controller card.....	108
Network daughter card.....	109
Removing the network daughter card.....	109
Installing the network daughter card.....	110
Processors and heat sinks.....	111
Removing a heat sink.....	112
Removing a processor.....	113
Installing a processor.....	115
Installing a heat sink.....	118
Power supply units (PSU).....	119
Hot spare feature.....	120
Removing the power supply unit blank.....	120
Installing the power supply unit blank.....	121
Removing an AC power supply unit.....	121
Installing an AC power supply unit.....	122
Wiring instructions for a DC power supply unit.....	123
Removing a DC power supply unit.....	126
Installing a DC power supply unit.....	127
System battery	128
Replacing the system battery.....	128
Hard drive backplane.....	129
Removing the hard drive backplane.....	130

Installing the hard drive backplane.....	136
Control panel assembly.....	137
Removing the control panel board–eight hard drive system.....	137
Installing the control panel board–eight hard drive system.....	138
Removing the control panel–eight hard drive system.....	139
Installing the control panel–eight hard drive system.....	140
Removing the control panel–10 hard drive and 24 hard drive system.....	141
Installing the control panel–10 hard drive system and 24 hard drive system.....	142
VGA module.....	143
Removing the VGA module.....	144
Installing the VGA module.....	145
System board.....	146
Removing the system board.....	146
Installing the system board.....	148
Trusted Platform Module.....	151
Installing the Trusted Platform Module.....	151
Initializing the TPM for BitLocker users.....	152
Initializing the TPM for TXT users.....	152
Chapter 7: Technology and Components.....	153
iDRAC8.....	153
Processor.....	156
Supported Processors.....	157
Chipset.....	158
Memory.....	159
General memory module installation guidelines.....	160
Mode-specific guidelines.....	160
Sample memory configurations.....	161
Storage.....	164
Backplane.....	164
PERC9.....	166
Power Supplies.....	166
Internal Dual SD Module.....	168
PCIe Risers and Slots	169
Network Daughter Card.....	170
Video.....	173
Trusted Platform Module	173
System Board Block Diagram.....	174
Chapter 8: Using system diagnostics.....	175
Dell Embedded System Diagnostics.....	175
Running the Embedded System Diagnostics from Boot Manager.....	175
Running the Embedded System Diagnostics from the Dell Lifecycle Controller.....	175
System diagnostics controls.....	175
Chapter 9: Jumpers and connectors	177
System board jumper settings.....	177
System board jumpers and connectors.....	178
Disabling a forgotten password.....	180

Chapter 10: Troubleshooting your system.....	181
Minimum configuration to POST	181
Troubleshooting system startup failure.....	182
Troubleshooting external connections.....	182
Troubleshooting the video subsystem.....	182
Troubleshooting a USB device.....	182
Troubleshooting iDRAC Direct - USB XML configuration.....	183
Troubleshooting iDRAC Direct - Laptop connection.....	183
Troubleshooting a serial input and output device.....	184
Troubleshooting a NIC.....	184
Troubleshooting a wet system.....	184
Troubleshooting a damaged system.....	185
Troubleshooting the system battery.....	186
Troubleshooting power supply units.....	187
Troubleshooting power source problems.....	187
Power supply unit problems.....	187
Troubleshooting cooling problems.....	188
Troubleshooting cooling fans.....	188
Troubleshooting system memory.....	189
Troubleshooting an internal USB key.....	190
Troubleshooting a micro SD card.....	190
Troubleshooting an optical drive.....	191
Troubleshooting a tape backup unit.....	191
Troubleshooting a drive or SSD.....	192
Troubleshooting a storage controller.....	193
Troubleshooting expansion cards.....	193
Troubleshooting processors.....	194
 Chapter 11: Getting help.....	 196
Contacting Dell.....	196
Documentation feedback.....	196
Accessing system information by using QRL.....	196
Quick Resource Locator for R630.....	197

Dell PowerEdge R630 system overview

The Dell PowerEdge R630 rack servers support up to:

- Two Intel Xeon E5-2600 v3 or v4 processors
- 24 x 1.8-inch hard drives or 10 x 2.5-inch hard drives or eight x 2.5-inch hard drives
- Four optional NVMe Express Flash PCIe SSDs
- 24 DIMM slots supporting up to 1536 GB of memory
- Two AC or DC redundant power supply units

 **NOTE:** The Dell PowerEdge R630 system supports hot swappable hard drives.

Topics:

- [Supported configurations for PowerEdge R630 system](#)
- [Front panel](#)
- [Back panel features](#)
- [Diagnostic indicators on the front panel](#)
- [Locating service tag of your system](#)

Supported configurations for PowerEdge R630 system

The Dell PowerEdge R630 system supports the following configurations:

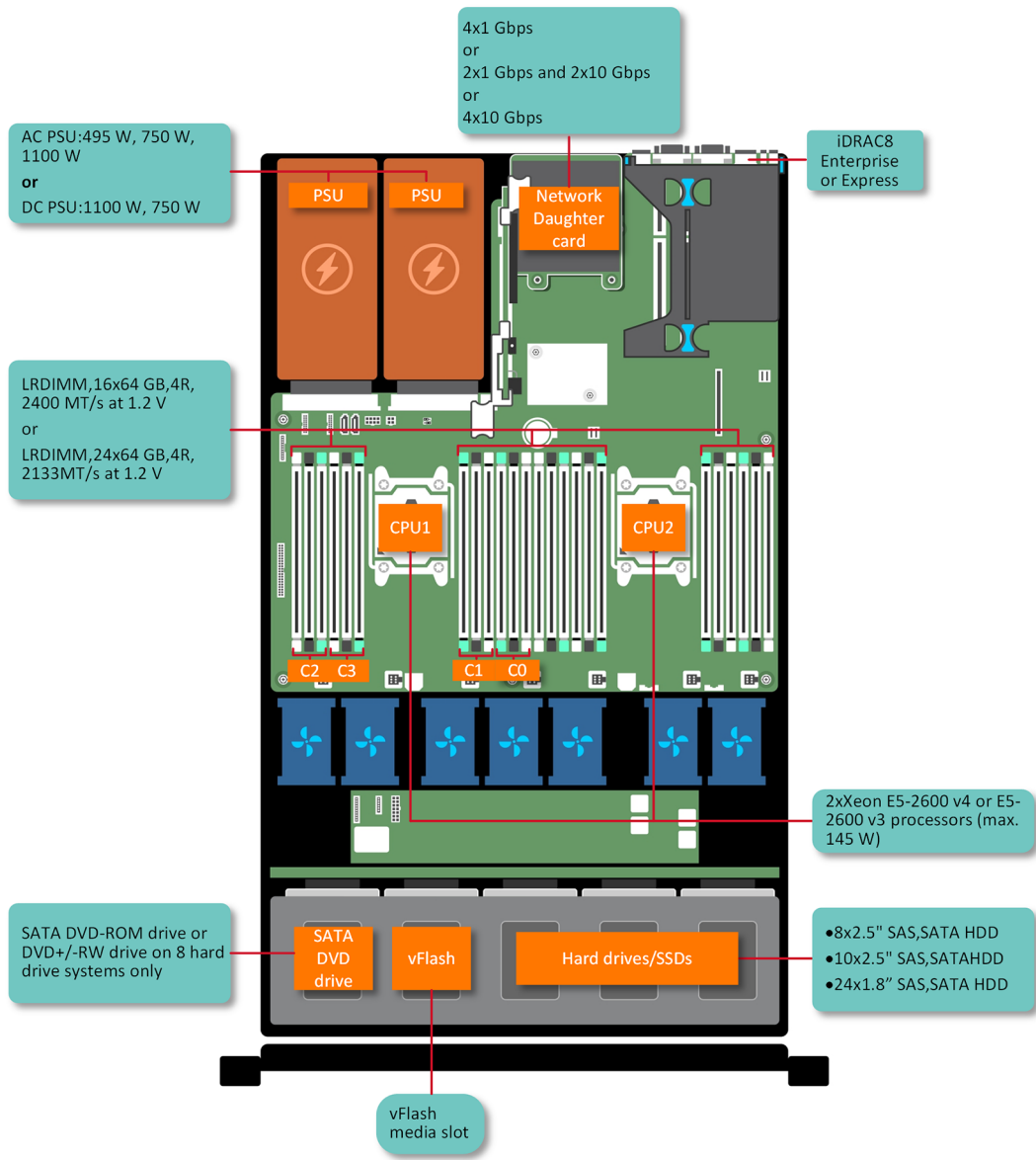

Figure 1. Supported configurations for PowerEdge R630 system

Front panel

The front panel provides access to the features available on the front of the server, such as the power button, NMI button, system identification tag, system identification button, and USB and VGA ports. The diagnostic LEDs or the LCD panel is prominently located on the front panel. The hot swappable hard drives are accessible from the front panel.

10 x 2.5-inch hard drive chassis

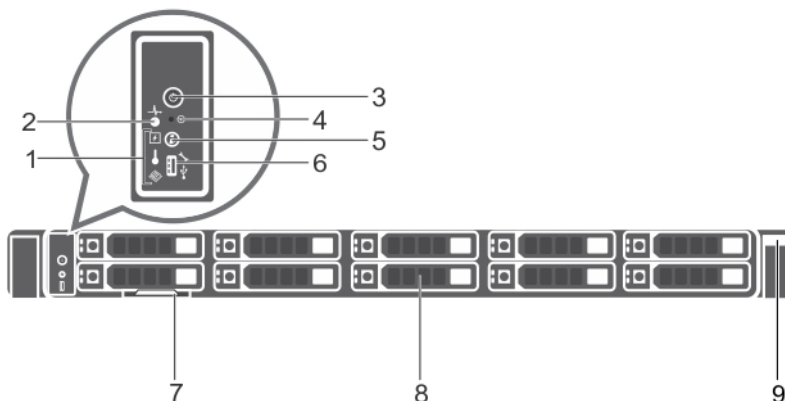



Figure 2. Front panel features of the 10 x 2.5-inch hard drive PowerEdge R630 chassis

- | | |
|-------------------------------------|--------------------------------|
| 1. Diagnostic indicators | 2. System health indicator |
| 3. Power-on indicator, power button | 4. NMI button |
| 5. System identification button | 6. Micro USB port/iDRAC Direct |
| 7. Information tag | 8. Hard drives (10) |
| 9. Quick Sync | |

Table 1. Front panel features of the 10 x 2.5-inch hard drive PowerEdge R630 chassis

Item	Indicator, Button, or Connector	Icon	Description
1	Diagnostic indicators		The diagnostic indicators light up to display error status.
2	System health indicator		The system health indicator flashes amber when a system fault is detected.
3	Power-on indicator, power button		The power indicator turns on when the system power is on. The power button controls the power supply output to the system. NOTE: On ACPI-compliant operating systems, turning off the system by using the power button causes the system to perform a graceful shutdown before power to the system is turned off.
4	NMI button		Used to troubleshoot software and device driver errors when running certain operating systems. This button can be pressed by using the end of a paper clip. NOTE: Use this button only if directed to do so by qualified support personnel or by the operating system documentation.
5	System identification button		The identification buttons on the front and back panels can be used to locate a particular system within a rack. When one of these buttons is pressed, the system status indicator on the back flashes until one of the buttons is pressed again.

Table 1. Front panel features of the 10 x 2.5-inch hard drive PowerEdge R630 chassis (continued)

Item	Indicator, Button, or Connector	Icon	Description
			Press to toggle the system ID on or off.
			If the system stops responding during POST, press and hold the system ID button for more than five seconds to enter BIOS progress mode.
			To reset the iDRAC (if not disabled in F2 iDRAC setup), press and hold the button for more than 15 seconds.
6	Micro USB port/iDRAC Direct		Enables you to connect USB devices to the system or provides access to the iDRAC Direct features. For more information, see the Integrated Dell Remote Access Controller User's Guide at Dell.com/idracmanuals . The port is USB 3.0-compliant.
7	Information tag		Contains system information such as service tag, NIC, MAC address for your reference. The information tag is a slide-out label panel.
8	Hard drives (10)		Up to ten 2.5-inch hot swappable hard drives. Up to six 2.5-inch hot swappable hard drives and up to four 2.5-inch Dell PowerEdge Express Flash devices (PCIe SSDs).
9	Quick Sync		Indicates a Quick Sync enabled system. The Quick Sync feature is optional and needs a Quick Sync bezel. This feature allows management of the system by using mobile devices. This feature aggregates hardware or firmware inventory and various system level diagnostic and error information that can be used in troubleshooting the system. For more information, see the Integrated Dell Remote Access Controller User's Guide at Dell.com/idracmanuals .

Eight x 2.5-inch hard drive chassis

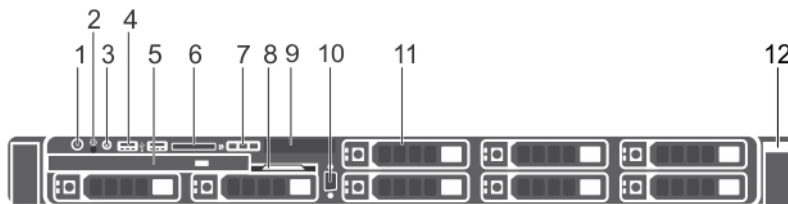

Figure 3. Front panel features of the eight x 2.5-inch PowerEdge R630 hard drive chassis

- | | |
|-------------------------------------|--|
| 1. Power-on indicator, power button | 2. NMI button |
| 3. System identification button | 4. USB management port or iDRAC Direct (2) |
| 5. Optical drive (optional) | 6. SD vFlash media card slot |
| 7. LCD menu buttons | 8. Information tag |
| 9. LCD panel | 10. Video connector |
| 11. Hard drives (8) | 12. Quick Sync |

Table 2. Front panel features of the eight x 2.5-inch PowerEdge R630 hard drive chassis







Item	Indicator, Button, or Connector	Icon	Description
1	Power-on indicator, power button		<p>Enables you to know the power status of the system. The power indicator turns on when the system power is on. The power button controls the power supply output to the system.</p> <p>NOTE: On Advanced Configuration and Power Interface (ACPI)-compliant operating systems, turning off the system by using the power button causes the system to perform a graceful shutdown before power to the system is turned off.</p>
2	NMI button		<p>Enables you to troubleshoot software and device driver errors when running certain operating systems. This button can be pressed by using the end of a paper clip.</p> <p>NOTE: Use this button only if directed to do so by qualified support personnel or by the operating system documentation.</p>
3	System identification button		<p>Enables you to locate a particular system within a rack. The identification buttons are on the front and back panels. When one of these buttons is pressed, the LCD panel on the front and the system status indicator on the back flash until one of the buttons is pressed again.</p> <p>To turn the system ID on or off, press the system identification button.</p> <p>If the system stops responding during POST, press and hold the system ID button for more than five seconds to enter BIOS progress mode.</p> <p>To reset the iDRAC (if not disabled in F2 iDRAC setup), press and hold the button for more than 15 seconds.</p>
4	USB management port/iDRAC Direct (2)		<p>Functions as a regular USB port or provides access to the iDRAC Direct features. For more information, see the iDRAC Guide at Dell.com/idracmanuals.</p> <p>The ports are USB 3.0-compliant.</p>
5	Optical drive (optional)		<p>One optional SATA DVD-ROM drive or DVD+/-RW drive.</p> <p>NOTE: DVD devices are data only.</p>
6	SD vFlash media card slot		<p>Enables you to insert a vFlash media card.</p>
7	LCD menu buttons		<p>Enables you to navigate the control panel LCD menu.</p>
8	Information tag		<p>Contains system information such as service tag, NIC, MAC address for your reference. The information tag is a slide-out label panel.</p>
9	LCD panel		<p>Displays system ID, status information, and system error messages. The LCD turns blue during normal system operation. When the system needs attention, the LCD turns amber and the LCD panel displays an error code followed by descriptive text.</p> <p>NOTE: If the system is connected to AC power and an error is detected, the LCD turns amber regardless of whether the system is turned on or off.</p>
10	Video connector		<p>Enables you to connect a VGA display to the system.</p>
11	Hard drives (8)		<p>Up to eight 2.5-inch hot swappable hard drives.</p>

Table 2. Front panel features of the eight x 2.5-inch PowerEdge R630 hard drive chassis (continued)

Item	Indicator, Button, or Connector	Icon	Description
12.	Quick Sync		Indicates a Quick Sync enabled system. The Quick Sync feature is optional and needs a Quick Sync bezel. This feature allows management of the system by using mobile devices. This feature aggregates hardware or firmware inventory and various system level diagnostic and error information that can be used in troubleshooting the system. For more information, see the Integrated Dell Remote Access Controller User's Guide at Dell.com/idracmanuals .

24 x 1.8-inch hard drive chassis

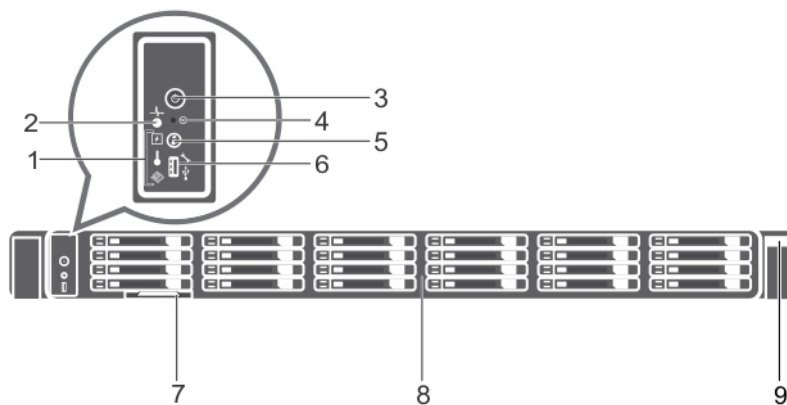



Figure 4. Front panel features of the 24 x 1.8-inch hard drive PowerEdge R630 chassis

- | | |
|-------------------------------------|----------------------------|
| 1. Diagnostic indicators | 2. System health indicator |
| 3. Power-on indicator, power button | 4. NMI button |
| 5. System identification button | 6. Micro USB port |
| 7. Information tag | 8. Hard drives (24) |
| 9. Quick Sync | |

Table 3. Front panel features of the 24 x 1.8-inch hard drive PowerEdge R630 chassis

Item	Indicator, Button, or Connector	Icon	Description
1	Diagnostic indicators		The diagnostic indicators light up to display error status.
2	System health indicator		The system health indicator flashes amber when a system fault is detected.
3	Power-on indicator, power button		The power indicator turns on when the system power is on. The power button controls the power supply output to the system. NOTE: On ACPI-compliant operating systems, turning off the system by using the power button causes the system to perform a graceful shutdown before power to the system is turned off.
4	NMI button		Used to troubleshoot software and device driver errors when running certain operating systems. This button can be pressed by using the end of a paper clip.

Table 3. Front panel features of the 24 x 1.8-inch hard drive PowerEdge R630 chassis (continued)

Item	Indicator, Button, or Connector	Icon	Description
			<p>i NOTE: Use this button only if directed to do so by qualified support personnel or by the operating system documentation.</p>
5	System identification button		<p>The identification buttons on the front and back panels can be used to locate a particular system within a rack. When one of these buttons is pressed, the system status indicator on the back flashes until one of the buttons is pressed again. Press to toggle the system ID on or off.</p> <p>If the system stops responding during POST, press and hold the system ID button for more than five seconds to enter BIOS progress mode.</p> <p>To reset the iDRAC (if not disabled in F2 iDRAC setup), press and hold the button for more than 15 seconds.</p>
6	Micro USB port		<p>Enables you to connect USB devices to the system or provides access to the iDRAC Direct features. For more information, see the Integrated Dell Remote Access Controller User's Guide at Dell.com/idracmanuals. The port is USB 3.0-compliant.</p>
7	Information tag		<p>Contains system information such as service tag, NIC, MAC address for your reference. The information tag is a slide-out label panel.</p>
8	Hard drives (24)		<p>Up to twenty four 1.8-inch hot swappable hard drives.</p>
9	Quick Sync		<p>Indicates a Quick Sync enabled system. The Quick Sync feature is optional and needs a Quick Sync bezel. This feature allows management of the system by using mobile devices. This feature aggregates hardware or firmware inventory and various system level diagnostic and error information that can be used in troubleshooting the system. For more information, see the Integrated Dell Remote Access Controller User's Guide at Dell.com/idracmanuals.</p>

LCD panel

The LCD panel of your system provides system information, status, and error messages to indicate if the system is functioning correctly or if the system needs attention. For more information about error messages, see the *Dell Event and Error Messages Reference Guide* at **Dell.com/openmanagemanuals >OpenManage software**.

- The LCD backlight turns blue during normal operating conditions.
- When the system needs attention, the LCD turns amber, and displays an error code followed by descriptive text.
 - i** **NOTE:** If the system is connected to a power source and an error is detected, the LCD turns amber regardless of whether the system is turned on or off.
- The LCD backlight is turned off when the system is in standby mode and can be turned on by pressing either the Select, Left, or Right button on the LCD panel.
- The LCD backlight remains off if LCD messaging is turned off using the iDRAC utility, the LCD panel, or other tools.

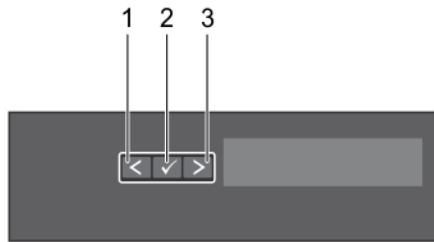





Figure 5. LCD panel features

Table 4. LCD panel features

Item	Button	Description
1	Left	Moves the cursor back in one-step increments.
2	Select	Selects the menu item highlighted by the cursor.
3	Right	<p>Moves the cursor forward in one-step increments.</p> <p>During message scrolling:</p> <ul style="list-style-type: none"> • Press and hold the button to increase scrolling speed. • Release the button to stop. <p>NOTE: The display stops scrolling when the button is released. After 45 seconds of inactivity, the display starts scrolling.</p>

Viewing Home screen

The **Home** screen displays user-configurable information about the system. This screen is displayed during normal system operation when there are no status messages or errors. When the system turns off and there are no errors, LCD enters the standby mode after five minutes of inactivity. Press any button on the LCD to turn it on.

1. To view the **Home** screen, press one of the three navigation buttons (Select, Left, or Right).
2. To navigate to the **Home** screen from another menu, complete the following steps:
 - a. Press and hold the navigation button till the up arrow  is displayed.
 - b. Navigate to the  using the up arrow .
 - c. Select the **Home** icon.
 - d. On the **Home** screen, press the **Select** button to enter the main menu.

Setup menu

NOTE: When you select an option in the Setup menu, you must confirm the option before proceeding to the next action.

Option	Description
iDRAC	Select DHCP or Static IP to configure the network mode. If Static IP is selected, the available fields are IP , Subnet (Sub) , and Gateway (Gtw) . Select Setup DNS to enable DNS and to view domain addresses. Two separate DNS entries are available.
Set error	<p>Select SEL to view LCD error messages in a format that matches the IPMI description in the SEL. This enables you to match an LCD message with an SEL entry.</p> <p>Select Simple to view LCD error messages in a simplified user-friendly description. For more information about error messages, see the <i>Dell Event and Error Messages Reference Guide</i> at Dell.com/openmanagemanuals > OpenManage software.</p>
Set home	Select the default information to be displayed on the Home screen. See View menu section for the options and option items that can be set as the default on the Home screen.

Related references

[View menu](#)

View menu

NOTE: When you select an option in the View menu, you must confirm the option before proceeding to the next action.

Option	Description
iDRAC IP	Displays the IPv4 or IPv6 addresses for iDRAC8. Addresses include DNS (Primary and Secondary) , Gateway, IP , and Subnet (IPv6 does not have Subnet).
MAC	Displays the MAC addresses for iDRAC , iSCSI , or Network devices.
Name	Displays the name of the Host , Model , or User String for the system.
Number	Displays the Asset tag or the Service tag for the system.
Power	Displays the power output of the system in BTU/hr or Watts. The display format can be configured in the Set home submenu of the Setup menu.
Temperature	Displays the temperature of the system in Celsius or Fahrenheit. The display format can be configured in the Set home submenu of the Setup menu.

Back panel features

The back panel provides access to the features available on the back of the server, such as the system identification button, power supply sockets, cable management arm connectors, iDRAC storage media, NIC ports, and USB and VGA ports. A majority of the expansion card ports can be accessed from the back panel. The hot swappable power supply units, and if installed, the rear accessible hard drives are accessible from the back panel.

Two-riser chassis

NOTE: This is only applicable for eight x 2.5-inch hard drive chassis.

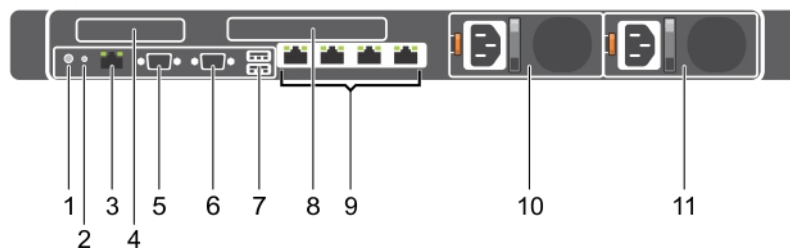









Figure 6. Back panel features (two PCIe expansion cards)

1. System identification button
2. System identification connector
3. iDRAC8 Enterprise port
4. PCIe expansion card slot (riser 1)
5. Serial connector
6. Video connector
7. USB ports (2)
8. PCIe expansion card slot (riser 2)
9. Ethernet connectors (4)
10. Power supply unit (PSU1)
11. Power supply unit (PSU2)

Table 5. Back panel features (two PCIe expansion cards)

Item	Indicator, Button, or Connector	Icon	Description
1	System identification button		<p>The identification buttons on the front and back panels can be used to locate a particular system within a rack. When one of these buttons is pressed, the LCD panel on the front and the system status indicator on the back flash until one of the buttons is pressed again.</p> <p>Press to toggle the system ID on and off. If the system stops responding during POST, press and hold the system ID button for more than five seconds to enter BIOS progress mode.</p> <p>To reset iDRAC (if not disabled in F2 iDRAC setup), press and hold for more than 15 seconds.</p>
2	System identification connector		Enables you to connect the optional system status indicator assembly through the optional cable management arm.
3	iDRAC8 Enterprise port		<p>Dedicated management port.</p> <p> NOTE: The port is available for use only if the iDRAC8 Enterprise license is installed on your system.</p>
4	PCIe expansion card slot (riser 1)		Enables you to connect a low profile PCIe expansion card. See the Expansion card installation guidelines section.
5	Serial connector		Enables you to connect a serial device to the system.
6	Video connector		Enables you to connect a VGA display to the system.
7	USB ports (2)		Enables you to connect USB devices to the system. The ports are USB 3.0-compliant.
8	PCIe expansion card slot (riser 2)		Enables you to connect a full height three-fourth length PCIe expansion card. See the Expansion card installation guidelines section.
9	Ethernet connectors (4)		<p>Four integrated 10/100/1000 Mbps NIC connectors</p> <p>or</p> <p>Four integrated connectors:</p> <ul style="list-style-type: none"> • Two integrated 10/100/1000 Mbps NIC connectors • Two integrated 100 Mbps/1 Gbps/10 Gbps SFP+ connectors <p>or</p> <ul style="list-style-type: none"> • Four 10 Gbps
10	PSU1		<ul style="list-style-type: none"> • Two 495 W, 750 W, or 1100 W AC power supply units (PSUs) <p>Or</p> <ul style="list-style-type: none"> • Two 1100 W DC PSUs <p>Or</p> <ul style="list-style-type: none"> • Two 750 W mixed mode PSUs
11	PSU2		<ul style="list-style-type: none"> • Two 495 W, 750 W, or 1100 W AC PSUs <p>Or</p> <ul style="list-style-type: none"> • Two 1100 W DC PSUs <p>Or</p> <ul style="list-style-type: none"> • Two 750 W mixed mode PSUs

Related references

[Expansion card installation guidelines](#)

Three-riser chassis

NOTE: This is applicable for eight x 2.5-inch, 10 x 2.5-inch, or 24 x 1.8-inch hard drive chassis.

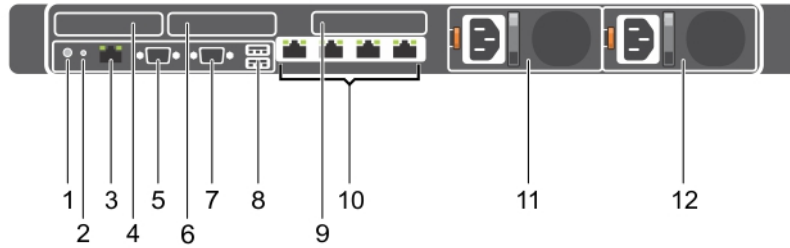





Figure 7. Back panel features (three PCIe expansion cards)

- | | |
|--|--|
| 1. System identification button | 2. System identification connector |
| 3. iDRAC8 Enterprise port | 4. LP PCIe expansion card slot (riser 1) |
| 5. Serial connector | 6. LP PCIe expansion card slot (riser 2) |
| 7. Video connector | 8. USB port (2) |
| 9. LP PCIe expansion card slot (riser 3) | 10. Ethernet connectors (4) |
| 11. Power supply (PSU1) | 12. Power supply (PSU2) |

Table 6. Back panel features (three PCIe expansion cards)

Item	Indicator, Button, or Connector	Icon	Description
1	System identification button		<p>The identification buttons on the front and back panels can be used to locate a particular system within a rack.</p> <p>10/24 hard drive system When one of these buttons is pressed, the system status indicator on the back flashes until one of the buttons is pressed again.</p> <p>Eight hard drive system When one of these buttons is pressed, the LCD panel on the front and the system status indicator on the back flashes until one of the buttons is pressed again.</p> <p>Press to toggle the system ID on and off. If the system stops responding during POST, press and hold the system ID button for more than five seconds to enter BIOS progress mode.</p> <p>To reset iDRAC (if not disabled in F2 iDRAC setup) press and hold for more than 15 seconds.</p>
2	System identification connector		Enables you to connect the optional system status indicator assembly through the optional cable management arm.
3	iDRAC8 Enterprise port		<p>Dedicated management port.</p> <p>NOTE: The port is available for use only if the iDRAC8 Enterprise license is installed on your system.</p>
4	LP PCIe expansion card slot (riser 1)		Enables you to connect a low profile LP PCIe expansion card. See the Expansion card installation guidelines section.

Table 6. Back panel features (three PCIe expansion cards) (continued)

Item	Indicator, Button, or Connector	Icon	Description
5	Serial connector		Enables you to connect a serial device to the system.
6	LP PCIe expansion card slot (riser 2)		Enables you to connect a low profile LP PCIe expansion card. See the Expansion card installation guidelines section.
7	Video connector		Enables you to connect a VGA display to the system.
8	USB port (2)		Enables you to connect USB devices to the system. The ports are USB 3.0-compliant.
9	LP PCIe expansion card slot (riser 3)		Enables you to connect a LP PCIe expansion card. See the Expansion card installation guidelines section.
10	Ethernet connectors (4)		Four integrated 10/100/1000 Mbps NIC connectors or Four integrated connectors: <ul style="list-style-type: none"> • Two integrated 10/100/1000 Mbps NIC connectors • Two integrated 100 Mbps/1 Gbps/10 Gbps SFP+ connectors
11	PSU1		or <ul style="list-style-type: none"> • Four 10 Gbps • Two 495 W, 750 W, or 1100 W AC power supply units (PSUs) Or <ul style="list-style-type: none"> • Two 1100 W DC PSUs Or <ul style="list-style-type: none"> • Two 750 W mixed mode PSUs
12	PSU2		• Two 495 W, 750 W, or 1100 W AC PSUs Or • Two 1100 W DC PSUs Or • Two 750 W mixed mode PSUs

Related references

[Expansion card installation guidelines](#)

Diagnostic indicators on the front panel

 **NOTE:** The diagnostic indicators are present only on the 10 hard drive and the 24 hard drive systems.

 **NOTE:** No diagnostic indicators are lit when the system is turned off. To start the system, plug it into a working power source and press the power button.

Table 7. Diagnostic indicators





Icon	Description	Condition	Corrective action
	Health indicator	The indicator turns solid blue if the system is in good health.	None required.

Table 7. Diagnostic indicators (continued)

Icon	Description	Condition	Corrective action
	Hard drive indicator	<p>The indicator flashes amber:</p> <ul style="list-style-type: none"> • When the system is turned on. • When the system is in standby. • If any error condition exists. For example, a failed fan, PSU, or a hard drive. 	<p>Check the System Event Log or system messages for the specific issue. For more information about error messages, see the <i>Dell Event and Error Messages Reference Guide</i> at Dell.com/openmanagemanuals > OpenManage software.</p> <p>The POST process is interrupted without any video output due to invalid memory configurations. See the Getting help section.</p>
	Electrical indicator	<p>The indicator flashes amber if the system experiences an electrical error (for example, voltage out of range, or a failed power supply unit (PSU) or voltage regulator).</p>	<p>Check the System Event Log or system messages for the specific issue. If it is due to a problem with the PSU, check the LED on the PSU. Reseat the PSU. If the problem persists, see the Getting help section.</p>
	Temperature indicator	<p>The indicator flashes amber if the system experiences a thermal error (for example, the ambient temperature is out of range or fan failure).</p>	<p>Ensure that none of the following conditions exist:</p> <ul style="list-style-type: none"> • A cooling fan has been removed or has failed. • System cover, cooling shroud, EMI filler panel, memory module blank, or back filler bracket is removed. • Ambient temperature is too high. • External airflow is obstructed. <p>See the Getting help section.</p>
	Memory indicator	<p>The indicator flashes amber if a memory error occurs.</p>	<p>Check the system event log or system messages for the location of the failed memory. Reseat the memory module. If the problem persists, see the Getting help section.</p>

Related references

[Getting help](#)

[Expansion card installation guidelines](#)

Hard drive indicator codes

Each hard drive carrier has an activity indicator and a status indicator. The indicators provide information about the current status of the hard drive. The activity LED indicates whether hard drive is currently in use or not. The status LED indicates the power condition of the hard drive.

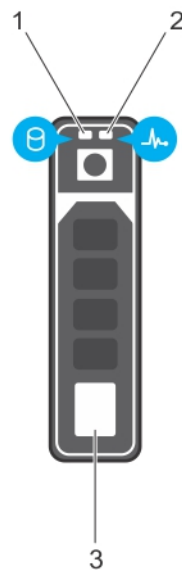

Figure 8. Hard drive indicators

1. Hard drive activity indicator
2. Hard drive status indicator
3. Hard drive

NOTE: If the hard drive is in the Advanced Host Controller Interface (AHCI) mode, the status indicator (on the right side) does not turn on.

Table 8. Hard drive indicator codes

Drive-status indicator pattern	Condition
Flashes green twice per second	Identifying drive or preparing for removal.
Off	Drive ready for insertion or removal. NOTE: The drive status indicator remains off until all hard drives are initialized after the system is turned on. Drives are not ready for insertion or removal during this time.
Flashes green, amber, and then turns off	Predicted drive failure
Flashes amber four times per second	Drive failed
Flashes green slowly	Drive rebuilding
Steady green	Drive online
Flashes green for three seconds, amber for three seconds, and then turns off after six seconds	Rebuild stopped

uSATA SSD indicator codes



Figure 9. uSATA SSD indicators

1. uSATA SSD activity indicator
2. uSATA SSD status indicator
3. uSATA SSD

NOTE: If the SSD is in the Advanced Host Controller Interface (AHCI) mode, the status indicator (on the right side) does not function and remains off.

Table 9. Drive status indicator codes

Drive-status indicator pattern	Condition
Flashes green twice per second	Identifying drive or preparing for removal.
Off	Drive ready for insertion or removal. NOTE: The drive status indicator remains off until all hard drives are initialized after the system is turned on. Drives are not ready for insertion or removal during this time.
Flashes green, amber, and turns off	Predicted drive failure
Flashes amber four times per second	Drive failed
Steady green	Drive online
Flashes green for three seconds, amber for three seconds, and turns off after six seconds	Rebuild aborted

NIC indicator codes

The NIC on the back panel has an indicator that provides information about the network activity and link status. The activity LED indicates whether the NIC is currently connected or not. The link LED indicates the speed of the connected network.

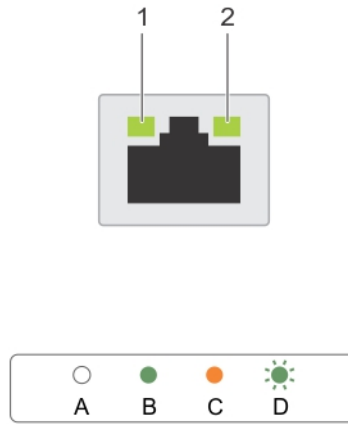

Figure 10. NIC Indicator Codes

1. link indicator
2. activity indicator

Table 10. NIC indicators

Convention	Status	Condition
A	Link and activity indicators are off.	The NIC is not connected to the network.
B	Link indicator is green.	The NIC is connected to a valid network at its maximum port speed (1 Gbps or 10 Gbps).
C	Link indicator is amber	The NIC is connected to a valid network at less than its maximum port speed.
D	Activity indicator is flashing. green	Network data is being sent or received.

Power supply unit indicator codes

AC power supply units (PSUs) have an illuminated translucent handle that serves as an indicator and DC PSUs have an LED that serves as an indicator. The indicator shows whether power is present or a power fault has occurred.



Figure 11. AC PSU status indicator

1. AC PSU status indicator/handle

Table 11. AC PSU status indicators

Convention	Power indicator pattern	Condition
A	Green	A valid power source is connected to the PSU and the PSU is operational.
B	Flashing green	When the firmware of the PSU is being updated, the PSU handle flashes green.
C	Flashing green and turns off	<p>When hot-adding a PSU, the PSU handle flashes green five times at 4 Hz rate and turns off. This indicates a PSU mismatch with respect to efficiency, feature set, health status, and supported voltage.</p> <p>NOTE: Ensure that both the PSUs are of the same capacity.</p> <p>CAUTION: For AC PSUs, use only PSUs with the Extended Power Performance (EPP) label on the back.</p> <p>NOTE: Mixing PSUs from previous generations of Dell PowerEdge servers can result in a PSU mismatch condition or failure to turn the system on.</p>
D	Flashing amber	<p>Indicates a problem with the PSU.</p> <p>CAUTION: When correcting a PSU mismatch, replace only the PSU with the flashing indicator. Swapping the PSU to make a matched pair can result in an error condition and unexpected system shutdown. To change from a high output configuration to a low output configuration or vice versa, you must turn off the system.</p> <p>CAUTION: AC PSUs support both 220 V and 110 V input voltages with the exception of Titanium PSUs, which support only 220 V. When two identical PSUs receive different input voltages, they can output different wattages, and trigger a mismatch.</p> <p>CAUTION: If two PSUs are used, they must be of the same type and have the same maximum output power.</p> <p>CAUTION: Combining AC and DC PSUs is not supported and triggers a mismatch.</p>
E	Not lit	Power is not connected.

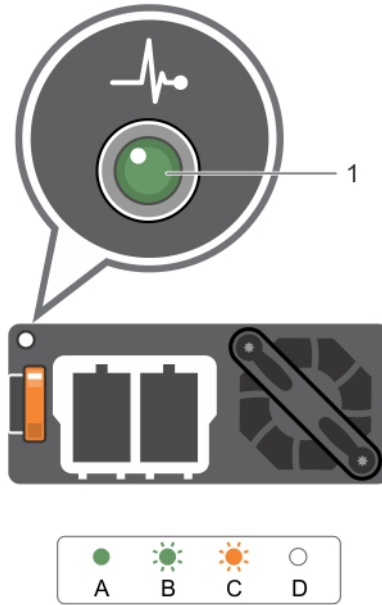

Figure 12. DC PSU status indicator

1. DC PSU status indicator

Table 12. DC PSU status indicators

Convention	Power indicator pattern	Condition
A	Green	A valid power source is connected to the PSU and that the PSU is operational.
B	Flashing green	When hot-adding a PSU, the PSU indicator flashes green. This indicates that there is a PSU mismatch with respect to efficiency, feature set, health status, and supported voltage. Ensure that both the PSUs are of the same capacity.
C	Flashing amber	Indicates a problem with the PSU. ⚠ CAUTION: When correcting a PSU mismatch, replace only the PSU with the flashing indicator. Swapping the PSU to make a matched pair can result in an error condition and unexpected system shutdown. To change from a High Output configuration to a Low Output configuration or vice versa, you must turn off the system. ⚠ CAUTION: AC PSU support both 220 V and 110 V input voltages with the exception of Titanium PSU, which support only 220 V. When two identical PSU receive different input voltages, they can output different wattages, and trigger a mismatch. ⚠ CAUTION: If two PSU are used, they must be of the same type and have the same maximum output power. ⚠ CAUTION: Combining AC and DC PSU is not supported and triggers a mismatch.
D	Not lit	Power is not connected.

iDRAC Direct LED indicator codes

The iDRAC Direct LED indicator lights up to indicate that the port is connected and is being used as a part of the iDRAC subsystem.

ⓘ NOTE: The iDRAC Direct LED indicator does not turn on when the USB port is used in the USB mode.

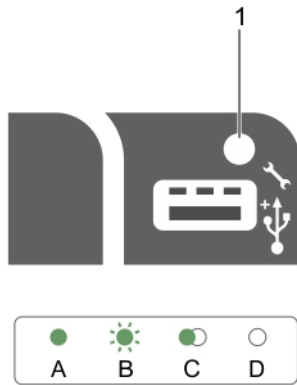

Figure 13. iDRAC Direct LED indicator codes

1. iDRAC Direct status indicator

The iDRAC Direct LED indicator table describes iDRAC Direct activity when configuring iDRAC Direct by using the management port (USB XML Import).

Table 13. iDRAC Direct LED indicators

Convention	iDRAC Direct LED indicator pattern	Condition
A	Green	Turns green for a minimum of two seconds to indicate the start and end of a file transfer.
B	Flashing green	Indicates file transfer or any operation tasks.
C	Green and turns off	Indicates that the file transfer is complete.
D	Not lit	Indicates that the USB is ready to be removed or that a task is complete.

The following table describes iDRAC Direct activity when configuring iDRAC Direct by using your laptop and cable (Laptop Connect):

Table 14. iDRAC Direct LED indicator patterns

iDRAC Direct LED indicator pattern	Condition
Solid green for two seconds	Indicates that the laptop is connected.
Flashing green (on for two seconds and off for two seconds)	Indicates that the laptop connected is recognized.
Turns off	Indicates that the laptop is unplugged.

Quick Sync indicator codes

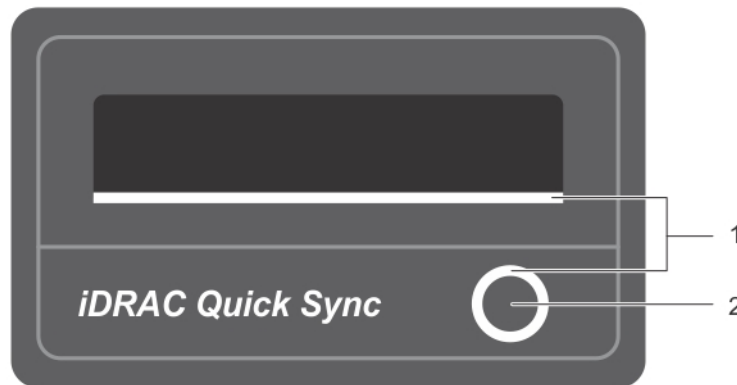

Figure 14. Quick Sync indicator codes

1. Quick Sync status indicator
2. Quick Sync activation button

Table 15. Quick Sync indicator codes

Power indicator pattern	Condition
Slow flash	Indicates that Quick Sync is waiting to be configured from iDRAC.
Solid	Indicates that Quick Sync is ready to transfer.
Flashes three times rapidly and then turns off	Indicates that the Quick Sync feature is disabled from iDRAC.
Flashes continuously when the mobile device touches the antenna	Indicates data transfer activity.
Flashes rapidly five times and turns off for one second when the activation button is pressed. This pattern is repeated until the activation button is pressed again.	Indicates that the Quick Sync hardware is not responding properly. Reseat the bezel. If the problem persists, see Getting help section.
Off	Indicates that the Quick Sync feature is turned off. Use the activation button to enable it. If pressing the activation button does not turn on the LEDs, it indicates that power is not delivered to the Quick Sync bezel. NOTE: For security purposes, Quick Sync turns off after 30 seconds of inactivity after the activation button is pressed. After timed-out, the user is expected to press the activation button again to activate Quick Sync.

Related references

[Getting help](#)

Locating service tag of your system

Your system is identified by a unique Express Service Code and Service Tag number. The Express Service Code and Service Tag are found on the front of the system by pulling out the information tag. Alternatively, the information may be on a sticker on the chassis of the system. This information is used by Dell to route support calls to the appropriate personnel.

Documentation resources

This section provides information about the documentation resources for your system.

To view the document that is listed in the documentation resources table:

- From the Dell EMC support site:
 1. Click the documentation link that is provided in the Location column in the table.
 2. Click the required product or product version.
-  **NOTE:** To locate the product name and model, see the front of your system.
- 3. On the Product Support page, click **Manuals & documents**.
- Using search engines:
 - Type the name and version of the document in the search box.

Table 16. Documentation resources

Task	Document	Location
Setting up your system	<p>For more information about installing and securing the system into a rack, see the Rail Installation Guide included with your rack solution.</p> <p>For information about setting up your system, see the <i>Getting Started Guide</i> document that is shipped with your system.</p>	https://www.dell.com/poweredgemanuals
Configuring your system	<p>For information about the iDRAC features, configuring and logging in to iDRAC, and managing your system remotely, see the Integrated Dell Remote Access Controller User's Guide.</p> <p>For information about understanding Remote Access Controller Admin (RACADM) subcommands and supported RACADM interfaces, see the RACADM CLI Guide for iDRAC.</p> <p>For information about Redfish and its protocol, supported schema, and Redfish Eventing implemented in iDRAC, see the Redfish API Guide.</p> <p>For information about iDRAC property database group and object descriptions, see the Attribute Registry Guide.</p> <p>For information about Intel QuickAssist Technology, see the Integrated Dell Remote Access Controller User's Guide.</p>	https://www.dell.com/poweredgemanuals
	<p>For information about earlier versions of the iDRAC documents.</p> <p>To identify the version of iDRAC available on your system, on the iDRAC web interface, click ? > About.</p>	https://www.dell.com/idracmanuals
	For information about installing the operating system, see the operating system documentation.	https://www.dell.com/operatingsystemmanuals

Table 16. Documentation resources (continued)

Task	Document	Location
	For information about updating drivers and firmware, see the Methods to download firmware and drivers section in this document.	www.dell.com/support/drivers
Managing your system	For information about system management software offered by Dell, see the Dell OpenManage Systems Management Overview Guide.	https://www.dell.com/poweredgemanuals
	For information about setting up, using, and troubleshooting OpenManage, see the Dell OpenManage Server Administrator User's Guide.	www.dell.com/openmanagemanuals > OpenManage Server Administrator
	For information about installing, using, and troubleshooting Dell OpenManage Enterprise, see the Dell OpenManage Enterprise User's Guide.	https://www.dell.com/openmanagemanuals
	For information about installing and using Dell SupportAssist, see the Dell EMC SupportAssist Enterprise User's Guide.	https://www.dell.com/serviceabilitytools
	For information about partner programs enterprise systems management, see the OpenManage Connections Enterprise Systems Management documents.	https://www.dell.com/openmanagemanuals
Working with the Dell PowerEdge RAID controllers	For information about understanding the features of the Dell PowerEdge RAID controllers (PERC), Software RAID controllers, or BOSS card and deploying the cards, see the Storage controller documentation.	www.dell.com/storagecontrollermanuals
Understanding event and error messages	For information about the event and error messages generated by the system firmware and agents that monitor system components, go to qrl.dell.com > Look Up > Error Code , type the error code, and then click Look it up .	www.dell.com/qrl
Troubleshooting your system	For information about identifying and troubleshooting the PowerEdge server issues, see the Server Troubleshooting Guide.	https://www.dell.com/poweredgemanuals

Technical specifications

The technical and environmental specifications of your system are outlined in this section.

Topics:

- Chassis dimensions
- Chassis weight
- Processor specifications
- PSU specifications
- System battery specifications
- Expansion bus specifications
- Memory specifications
- Drive specifications
- Ports and connectors specifications
- Video specifications
- Environmental specifications

Chassis dimensions

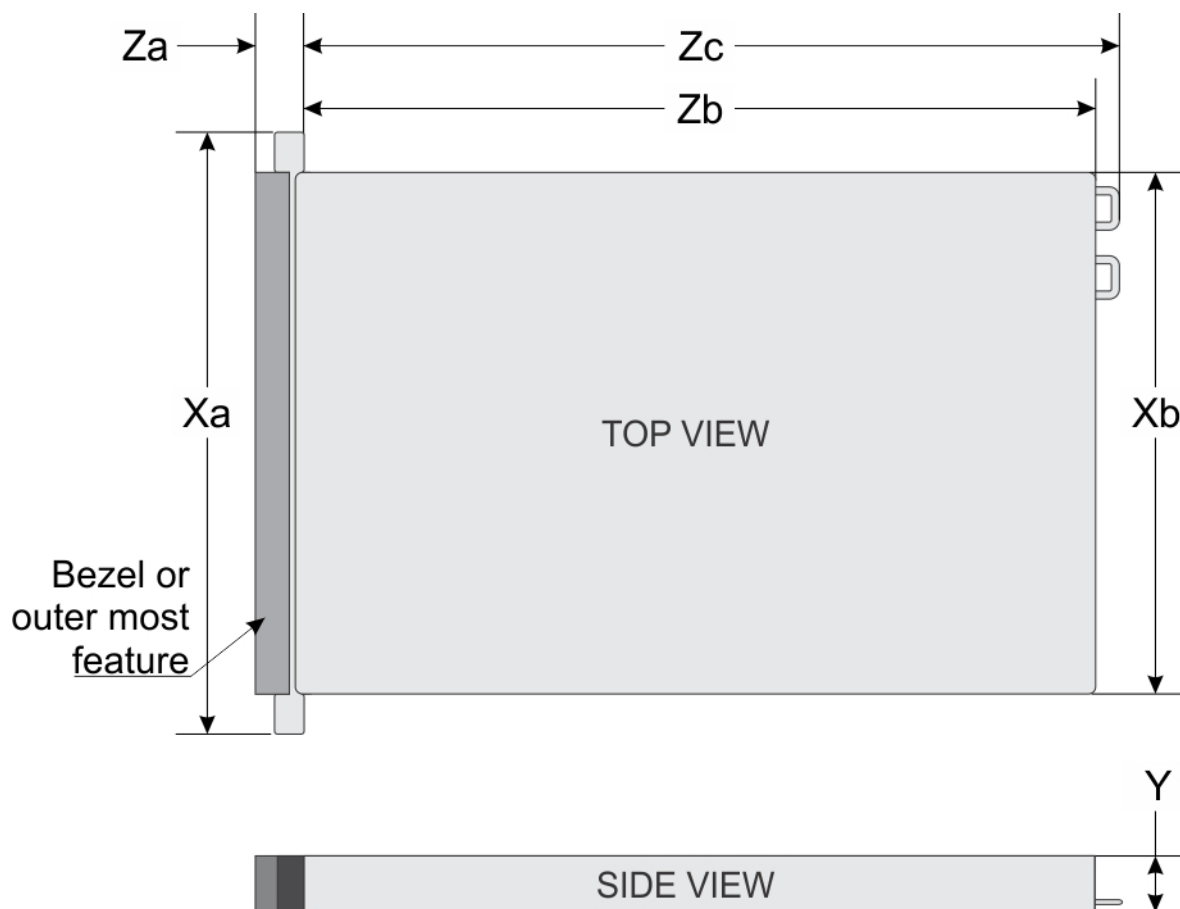

Figure 15. Chassis dimensions of PowerEdge R630 system

Table 17. Dimensions of the Dell PowerEdge R630 system

System	Xa	Xb	Y	Za (with bezel)	Za (without bezel)	Zb	Zc
Eight x 2.5-inch hard drive systems	482.4 mm (19 inches)	434.0 mm (17.0 inches)	42.8 mm (1.6 inches)	35.0 mm (1.3 inches)	20.4 mm (0.8 inches)	682.7 mm (26.8 inches)	701.3 mm (27.6 inches)
10 x 2.5-inch and 24 x 2.5-inch hard drive systems	482.4 mm (19 inches)	434.0 mm (17.0 inches)	42.8 mm (1.6 inches)	35.0 mm (1.3 inches)	20.4 mm (0.8 inches)	731.0 mm (28.7 inches)	752.1 mm (29.6 inches)

Chassis weight

Table 18. Chassis weight

System	Maximum weight
Eight x 2.5-inch hard drive systems	16.9 kg (37.26 lb)
10 x 2.5-inch hard drive systems	18.5 kg (40.79 lb)
24 x 1.8-inch hard drive systems	17.4 kg (38.36 lb)

Processor specifications

The PowerEdge R630 system supports up to two Intel Xeon E5-2600 v3 or v4 product family processors.

PSU specifications

The PowerEdge R630 system supports up to two AC or DC redundant power supply units (PSUs).

Table 19. PSU specifications

PSU	Class	Heat dissipation (maximum)	Frequency	Voltage
495 W AC	Platinum	1908 BTU/hr	50/60 Hz	100–240 V AC, autoranging
750 W AC	Platinum	2891 BTU/hr	50/60 Hz	100–240 V AC, autoranging
750 W AC	Titanium	2843 BTU/hr	50/60 Hz	200–240 V AC, autoranging
1100 W AC	Platinum	4100 BTU/hr	50/60 Hz	100–240 V AC, autoranging
1100 W DC	—	4416 BTU/hr	—	–(48–60) V DC
750 W DC (for China only)	Platinum	2902 BTU/hr	50/60 Hz	100–240 V AC and 240 V DC

NOTE: Heat dissipation is calculated by using the PSU wattage rating.

NOTE: This system is also designed to connect to the IT power systems with a phase to phase voltage not exceeding 230 V.

System battery specifications

The PowerEdge R630 system supports CR 2032 3.0-V lithium coin cell system battery.

Expansion bus specifications

The PowerEdge R630 system supports PCI express (PCIe) generation 3 expansion cards, which must be installed on the system board by using expansion card risers. This system supports three types of expansion card risers. The following table provides detailed information about the expansion card riser specifications:

Table 20. Expansion card riser specifications

Expansion card riser	PCIe slots on the riser	Height	Length	Link
Riser 1	Slot 1	Low Profile	Half Length	x16
	Slot 2	Low Profile	Half Length	x8
Riser 2	Slot 1	Low Profile	Half Length	x8
	Slot 1	Low Profile	Half Length	x16
Riser 3	Slot 2	Full height	Three-fourth Length	x16
	Slot 3	Low Profile	Half Length	x16

NOTE: When using slot 1 on the riser, ensure that both the processors are installed on the system.

NOTE: Only a three-fourth length card is supported for the PCIe expansion card slot (slot 2) on riser 3 when no mini-PERC card is installed. Supported length with mini-PERC card installed is half length.

Memory specifications

The PowerEdge R630 system supports DDR4 registered DIMMs (RDIMMs) and load-reduced DIMMs (LRDIMMs) at 1866 MT/s, 2133 MT/s, or 2400 MT/s.

Table 21. Memory specifications

Memory module sockets	Memory capacity	Minimum RAM	Maximum RAM
Twenty-four 288-pins	<ul style="list-style-type: none"> 64 GB quad rank (LRDIMMs) 4 GB or 8 GB single rank (RDIMMs) 8 GB, 16 GB or 32 GB dual rank (RDIMMs) 	<ul style="list-style-type: none"> 4 GB with single processor 8 GB with dual processors (minimum one memory module per processor) 	<ul style="list-style-type: none"> LRDIMM: Up to 768 GB with single processor LRDIMM: Up to 1536 GB with dual processors RDIMM: Up to 384 GB with single processor RDIMM: Up to 786 GB with dual processors

Drive specifications

Hard drives

The PowerEdge R630 system supports:

- Up to eight 2.5-inch, internal, hot swappable SAS, SATA, or Nearline SAS hard drives
- Up to ten 2.5-inch, internal, hot swappable SAS, SATA, or Nearline SAS hard drives

- Up to twenty four 1.8-inch, internal, hot swappable SAS, SATA, or Nearline SAS hard drives

Optical drive

The PowerEdge R630 system supports one optional SATA DVD-ROM drive or DVD+/-RW drive on 8 hard drive systems only.

Ports and connectors specifications

USB ports

The PowerEdge R630 system supports:

- USB 2.0-compliant ports on the front panel
- USB 3.0-complaint ports on the back panel
- Internal USB 3.0-compliant port

Table 22. USB specifications

System	Front panel	Back panel	Internal
PowerEdge R630	For eight hard drive systems: <ul style="list-style-type: none"> • Two 4-pin, USB 2.0-compliant ports • vFlash memory card slot For 24 or 10 hard drive systems: <ul style="list-style-type: none"> • One micro USB 2.0-compliant port 	Two 9-pin, USB 3.0-compliant ports	One 9-pin, USB 3.0-compliant ports

NIC ports

The PowerEdge R630 system supports four Network Interface Controller (NIC) ports on the back panel, which is available in one of the following three NIC configurations:

- Four 10/100/1000 Mbps
- Two 10/100/1000 Mbps and two 100 Mbps/1 Gbps/10 Gbps
- Four 10 Gbps

Serial connector

The serial connector connects a serial device to the system. The PowerEdge R630 system supports one serial connector on the back panel, which is a 9-pin connector, Data Terminal Equipment (DTE), 16550-compliant.

VGA ports

The Video Graphic Array (VGA) port enables you to connect the system to a VGA display. The PowerEdge R630 system supports two 15-pin VGA ports on the front and back panels.

Internal Dual SD Module

The PowerEdge R630 system supports two optional flash memory card slots with an internal dual SD module.

 **NOTE:** One card slot is dedicated for redundancy.

Video specifications

The PowerEdge R630 system supports Integrated VGA controller with 16 MB capacity.

Table 23. Resolution information for video modes

Resolution	Refresh rate (Hz)	Color depth (bit)
640 X 480	60, 70	8, 16, 32
800 X 600	60, 75, 85	8, 16, 32
1024 X 768	60, 75, 85	8, 16, 32
1152 X 864	60, 75, 85	8, 16, 32
1280 X 1024	60, 75	8, 16, 32
1440 X 900	60	8, 16, 32

Environmental specifications

NOTE: For additional information about environmental measurements for specific system configurations, see Dell.com/environmental_datasheets.

Table 24. Temperature specifications

Temperature	Specifications
Storage	-40°C to 65°C (-40°F to 149°F)
Continuous operation (for altitude less than 950 m or 3117 ft)	10°C to 35°C (50°F to 95°F) with no direct sunlight on the equipment. NOTE: Maximum of 145 W 22 core processor is supported in systems with eight 2.5-inches drives, two PCI slot chassis, and 75 W single wide active GPU.
Fresh air	For information about fresh air, see Expanded Operating Temperature section.
Maximum temperature gradient (operating and storage)	20°C/h (36°F/h)

Table 25. Relative humidity specifications

Relative humidity	Specifications
Storage	5% to 95% RH with 33°C (91°F) maximum dew point. Atmosphere must be non-condensing at all times.
Operating	10% to 80% relative humidity with 29°C (84.2°F) maximum dew point.

Table 26. Maximum vibration specifications

Maximum vibration	Specifications
Operating	0.26 G _{rms} at 5 Hz to 350 Hz (all operation orientations).
Storage	1.88 G _{rms} at 10 Hz to 500 Hz for 15 min (all six sides tested).

Table 27. Maximum shock specifications

Maximum shock	Specifications
Operating	Six consecutively executed shock pulses in the positive and negative x, y, and z axes of 40 G for up to 2.3 ms.

Table 27. Maximum shock specifications (continued)

Maximum shock	Specifications
Storage	Six consecutively executed shock pulses in the positive and negative x, y, and z axes (one pulse on each side of the system) of 71 G for up to 2 ms.

Table 28. Maximum altitude specifications

Maximum altitude	Specifications
Operating	30482000 m (10,0006560 ft)
Storage	12,000 m (39,370 ft)

Table 29. Operating temperature de-rating specifications

Operating temperature de-rating	Specifications
Up to 35°C (95°F)	Maximum temperature is reduced by 1°C/300 m (1°F/547 ft) above 950 m (3,117 ft).
35°C to 40°C (95°F to 104°F)	Maximum temperature is reduced by 1°C/175 m (1°F/319 ft) above 950 m (3,117 ft).
40°C to 45°C (104°F to 113°F)	Maximum temperature is reduced by 1°C/125 m (1°F/228 ft) above 950 m (3,117 ft).

Related references

[Expanded operating temperature](#)

Particulate and gaseous contamination specifications

The following table defines the limitations that help avoid any equipment damage or failure from particulates and gaseous contamination. If the level of particulates or gaseous pollution exceed the specified limitations and result in equipment damage or failure, you may need to rectify the environmental conditions. Re-mediation of environmental conditions is the responsibility of the customer.

Table 30. Particulate contamination specifications

Particulate contamination	Specifications
Air filtration	<p>Data center air filtration as defined by ISO Class 8 per ISO 14644-1 with a 95% upper confidence limit.</p> <p>i NOTE: This condition applies only to data center environments. Air filtration requirements do not apply to IT equipment designed to be used outside a data center, in environments such as an office or factory floor.</p> <p>i NOTE: Air entering the data center must have MERV11 or MERV13 filtration.</p>
Conductive dust	<p>Air must be free of conductive dust, zinc whiskers, or other conductive particles.</p> <p>i NOTE: This condition applies to data center and non-data center environments.</p>
Corrosive dust	<ul style="list-style-type: none"> Air must be free of corrosive dust. Residual dust present in the air must have a deliquescent point less than 60% relative humidity. <p>i NOTE: This condition applies to data center and non-data center environments.</p>

Table 31. Gaseous contamination specifications

Gaseous contamination	Specifications
Copper coupon corrosion rate	<300 Å/month per Class G1 as defined by ANSI/ISA71.04-1985.
Silver coupon corrosion rate	<200 Å/month as defined by AHSRAE TC9.9.

NOTE: Maximum corrosive contaminant levels measured at ≤50% relative humidity.

Standard operating temperature

Table 32. Standard operating temperature specifications

Standard operating temperature	Specifications
Temperature ranges (for altitude less than 950 metres or 3117 feet)	10°C to 35°C (50°F to 95°F) with no direct sunlight on the equipment. NOTE: Maximum of 145 W 22-core processor is supported in systems with eight 2.5-inch drives 2-PCI slot chassis, and 75 W single wide active GPU.
Standard operating temperature restrictions	<ul style="list-style-type: none"> Ambient temperature is restricted to 30°C for systems with eight 2.5-inches drives or ten 2.5-inch drives chassis, with no PCIe SSD and a maximum of 160 W workstation processor. Ambient temperature is restricted to 30°C for systems with ten 2.5-inch drives chassis, PCIe SSD and a maximum of 135 W processor. Ambient temperature is restricted to 35°C for systems with ten 2.5-inch drives chassis, PCIe SSD and a maximum of 120 W processor. Ambient temperature is restricted to 35°C for systems with twenty-four 1.8-inch drives chassis, PCIe SSD, and a maximum of 135 W processor.

Expanded operating temperature

Table 33. Expanded operating temperature specifications

Expanded operating temperature	Specifications
Continuous operation	5°C to 40°C at 5% to 85% RH with 29°C dew point. NOTE: Outside the standard operating temperature (10°C to 35°C), the system can operate continuously in temperatures as low as 5°C and as high as 40°C. For temperatures between 35°C and 40°C, de-rate maximum allowable temperature by 1°C per 175 m above 950 m (1°F per 319 ft).
≤ 1% of annual operating hours	-5°C to 45°C at 5% to 90% RH with 29°C dew point. NOTE: Outside the standard operating temperature (10°C to 35°C), the system can operate down to -5°C or up to 45°C for a maximum of 1% of its annual operating hours. For temperatures between 40°C and 45°C, de-rate maximum allowable temperature by 1°C per 125 m above 950 m (1°F per 228 ft).

NOTE: When operating in the expanded temperature range, system performance may be impacted.

 **NOTE:** When operating in the expanded temperature range, ambient temperature warnings may be reported on the LCD panel and in the System Event Log.

Expanded operating temperature restrictions

- Do not perform a cold startup below 5°C.
- The operating temperature specified is for a maximum altitude of 3050 m (10,000 ft).
- 145 W and Workstation CPU (160 W) processors are not supported.
- Two power supply units (PSUs) are needed and one PSU failure is not supported.
- Non-Dell qualified peripheral cards and/or peripheral cards greater than 25 W are not supported.
- PCIe SSD and 1.8-inch SSDs are not supported.
- GPU is not supported.

Initial system setup and configuration

Topics:

- [Setting up your system](#)
- [iDRAC configuration](#)
- [Options to install the operating system](#)

Setting up your system

Complete the following steps to set up your system:

1. Unpack the system.
2. Install the system into the rack. For more information about installing the system into the rack, see your system *Rack Installation Placemat* at [Dell.com/poweredgemanuals](https://www.dell.com/poweredgemanuals).
3. Connect the peripherals to the system.
4. Connect the system to its electrical outlet.
5. Turn the system on by pressing the power button or by using iDRAC.
6. Turn on the attached peripherals.

iDRAC configuration

The Integrated Dell Remote Access Controller (iDRAC) is designed to make system administrators more productive and improve the overall availability of Dell EMC systems. iDRAC alerts administrators to system issues, helps them perform remote system management, and reduces the need for physical access to the system.

Options to set up iDRAC IP address

You must configure the initial network settings based on your network infrastructure to enable the communication to and from iDRAC. You can set up the IP address by using one of the following interfaces:

Interfaces	Document/Section
iDRAC Settings utility	See <i>Integrated Dell Remote Access Controller User's Guide</i> available at https://www.dell.com/idracmanuals
Dell Deployment Toolkit	See <i>Dell EMC OpenManage Deployment Toolkit User's Guide</i> available at https://www.dell.com/openmanagemanuals
Dell Lifecycle Controller	See <i>Dell Lifecycle Controller User's Guide</i> available at https://www.dell.com/idracmanuals
Chassis or Server LCD panel	See the LCD panel section

You must use the default iDRAC IP address 192.168.0.120 to configure the initial network settings, including setting up DHCP or a static IP for iDRAC.

NOTE: To access iDRAC, ensure that you install the iDRAC port card or connect the network cable to the Ethernet connector 1 on the system board.

NOTE: Ensure that you change the default user name and password after setting up the iDRAC IP address.

Related references

[LCD panel](#)

Log in to iDRAC

You can log in to iDRAC as:

- iDRAC user
- Microsoft Active Directory user
- Lightweight Directory Access Protocol (LDAP) user

The default user name and password are `root` and `calvin`. You can also log in by using Single Sign-On or Smart Card.

 **NOTE:** You must have iDRAC credentials to log in to iDRAC.

For more information about logging in to iDRAC and iDRAC licenses, see the latest Integrated Dell Remote Access Controller User's Guide at [Dell.com/idracmanuals](https://www.dell.com/idracmanuals).

Options to install the operating system

If the system is shipped without an operating system, install the supported operating system by using one of the following resources:

Table 34. Resources to install the operating system

Resources	Location
Dell Systems Management Tools and Documentation media	https://www.dell.com/operatingsystemmanuals
Dell Lifecycle Controller	https://www.dell.com/idracmanuals
Dell OpenManage Deployment Toolkit	https://www.dell.com/openmanagemanuals
Dell certified VMware ESXi	https://www.dell.com/virtualizationsolutions
Supported operating systems on Dell PowerEdge systems	www.dell.com/ossupport
Installation and How-to videos for supported operating systems on Dell PowerEdge systems	https://www.youtube.com/playlist?list=PLe5xhhyFjDPfTCaDRFfIB_VsoLpL8x84G

Methods to download firmware and drivers

You can download the firmware and drivers by using any of the following methods:

Table 35. Firmware and drivers

Methods	Location
From the Dell Support site	Global Technical Support
Using Dell Remote Access Controller Lifecycle Controller (iDRAC with LC)	Dell.com/idracmanuals
Using Dell Repository Manager (DRM)	Dell.com/openmanagemanuals > OpenManage Deployment Toolkit
Using Dell OpenManage Essentials (OME)	Dell.com/openmanagemanuals > OpenManage Deployment Toolkit
Using Dell Server Update Utility (SUU)	Dell.com/openmanagemanuals > OpenManage Deployment Toolkit
Using Dell OpenManage Deployment Toolkit (DTK)	Dell.com/openmanagemanuals > OpenManage Deployment Toolkit

Downloading the drivers and firmware

Dell EMC recommends that you download and install the latest BIOS, drivers, and systems management firmware on your system.

Ensure that you clear the web browser cache before downloading the drivers and firmware.

1. Go to Dell.com/support/drivers.
2. In the **Drivers & Downloads** section, type the Service Tag of your system in the **Service Tag or Express Service Code** box, and then click **Submit**.

 **NOTE:** If you do not have the Service Tag, select **Detect My Product** to allow the system to automatically detect your Service Tag, or in **General support**, navigate to your product.

3. Click **Drivers & Downloads**.
The drivers that are applicable to your selection are displayed.
4. Download the drivers to a USB drive, CD, or DVD.

Pre-operating system management applications

You can manage basic settings and features of a system without booting to the operating system by using the system firmware.

Topics:

- [Options to manage the pre-operating system applications](#)
- [System Setup](#)
- [Dell Lifecycle Controller](#)
- [Boot Manager](#)
- [PXE boot](#)

Options to manage the pre-operating system applications

Your system has the following options to manage the pre-operating system applications:

- [System Setup](#)
- [Boot Manager](#)
- [Dell Lifecycle Controller](#)
- [Preboot Execution Environment \(PXE\)](#)

Related concepts

[System Setup](#)

[Boot Manager](#)

[Dell Lifecycle Controller](#)

[PXE boot](#)

System Setup

By using the **System Setup** screen, you can configure the BIOS settings, iDRAC settings, and device settings of your system.

 **NOTE:** Help text for the selected field is displayed in the graphical browser by default. To view the help text in the text browser, press F1.

You can access system setup by using two methods:

- Standard graphical browser — The browser is enabled by default.
- Text browser — The browser is enabled by using Console Redirection.

Related references

[System Setup details](#)

Related tasks

[Viewing System Setup](#)

Viewing System Setup

To view the **System Setup** screen, perform the following steps:

1. Turn on, or restart your system.
2. Press F2 immediately after you see the following message:

```
F2 = System Setup
```

NOTE: If your operating system begins to load before you press F2, wait for the system to finish booting, and then restart your system and try again.

Related concepts

[System Setup](#)

Related references

[System Setup details](#)

System Setup details

The **System Setup Main Menu** screen details are explained as follows:

Option	Description
System BIOS	Enables you to configure BIOS settings.
iDRAC Settings	Enables you to configure iDRAC settings. The iDRAC settings utility is an interface to set up and configure the iDRAC parameters by using UEFI (Unified Extensible Firmware Interface). You can enable or disable various iDRAC parameters by using the iDRAC settings utility. For more information about this utility, see <i>Integrated Dell Remote Access Controller User's Guide</i> at Dell.com/idracmanuals .
Device Settings	Enables you to configure device settings.

Related concepts

[System Setup](#)

Related references

[iDRAC Settings utility](#)

[Device Settings](#)

Related tasks

[Viewing System Setup](#)

System BIOS

You can use the **System BIOS** screen to edit specific functions such as boot order, system password, setup password, set the RAID mode, and enable or disable USB ports.

Related references

[System BIOS Settings details](#)

[Boot Settings](#)

[Network Settings](#)

[System Information](#)

[Memory Settings](#)

- [Processor Settings](#)
- [SATA Settings](#)
- [Integrated Devices](#)
- [Serial Communication](#)
- [System Profile Settings](#)
- [Miscellaneous Settings](#)
- [iDRAC Settings utility](#)
- [Device Settings](#)
- [System Security](#)

Related tasks

[Viewing System BIOS](#)

Viewing System BIOS

To view the **System BIOS** screen, perform the following steps:

1. Turn on, or restart your system.
2. Press F2 immediately after you see the following message:

```
F2 = System Setup
```

NOTE: If your operating system begins to load before you press F2, wait for the system to finish booting, and then restart your system and try again.

3. On the **System Setup Main Menu** screen, click **System BIOS**.

Related references

- [System BIOS](#)
- [System BIOS Settings details](#)

System BIOS Settings details

The **System BIOS Settings** screen details are explained as follows:

Option	Description
System Information	Specifies information about the system such as the system model name, BIOS version, and Service Tag.
Memory Settings	Specifies information and options related to the installed memory.
Processor Settings	Specifies information and options related to the processor such as speed and cache size.
SATA Settings	Specifies options to enable or disable the integrated SATA controller and ports.
Boot Settings	Specifies options to specify the boot mode (BIOS or UEFI). Enables you to modify UEFI and BIOS boot settings.
Network Settings	Specifies options to change the network settings.
Integrated Devices	Specifies options to manage integrated device controllers and ports and specify related features and options.
Serial Communication	Specifies options to manage the serial ports and specify related features and options.
System Profile Settings	Specifies options to change the processor power management settings, memory frequency, and so on.
System Security	Specifies options to configure the system security settings, such as system password, setup password, Trusted Platform Module (TPM) security. It also manages the power and NMI buttons on the system.

Option	Description
Miscellaneous Settings	Specifies options to change the system date, time, and so on.

Related references

[System BIOS](#)

Related tasks

[Viewing System BIOS](#)

Boot Settings

You can use the **Boot Settings** screen to set the boot mode to either **BIOS** or **UEFI**. It also enables you to specify the boot order.

Related references

[System BIOS](#)

[Choosing the system boot mode](#)

Related tasks

[Boot Settings details](#)

[Viewing Boot Settings](#)

[Changing the boot order](#)

Viewing Boot Settings

To view the **Boot Settings** screen, perform the following steps:

1. Turn on, or restart your system.
2. Press F2 immediately after you see the following message:

```
F2 = System Setup
```

 **NOTE:** If your operating system begins to load before you press F2, wait for the system to finish booting, and then restart your system and try again.

3. On the **System Setup Main Menu** screen, click **System BIOS**.
4. On the **System BIOS** screen, click **Boot Settings**.

Related references

[Boot Settings](#)

[Choosing the system boot mode](#)

Related tasks



[Boot Settings details](#)

[Changing the boot order](#)

Boot Settings details

The **Boot Settings** screen details are explained as follows:

Option	Description
Boot Mode	Enables you to set the boot mode of the system.

Option	Description
	<p> CAUTION: Switching the boot mode may prevent the system from booting if the operating system is not installed in the same boot mode.</p> <p>If the operating system supports UEFI, you can set this option to UEFI. Setting this field to BIOS allows compatibility with non-UEFI operating systems. This option is set to BIOS by default.</p> <p> NOTE: Setting this field to UEFI disables the BIOS Boot Settings menu. Setting this field to BIOS disables the UEFI Boot Settings menu.</p>
Boot Sequence Retry	Enables or disables the Boot Sequence Retry feature. If this option is set to Enabled and the system fails to boot, the system reattempts the boot sequence after 30 seconds. This option is set to Enabled by default.
Hard-Disk Failover	Specifies the hard drive that is booted in the event of a hard drive failure. The devices are selected in the Hard-Disk Drive Sequence on the Boot Option Setting menu. When this option is set to Disabled , only the first hard drive in the list is attempted to boot. When this option is set to Enabled , all hard drives are attempted to boot in the order selected in the Hard-Disk Drive Sequence . This option is not enabled for UEFI Boot Mode.
Boot Option Settings	Configures the boot sequence and the boot devices.

Related references

[Boot Settings](#)

[Choosing the system boot mode](#)

Related tasks

[Viewing Boot Settings](#)

[Changing the boot order](#)

Choosing the system boot mode

System Setup enables you to specify one of the following boot modes for installing your operating system:

- BIOS boot mode (the default) is the standard BIOS-level boot interface.
 - Unified Extensible Firmware Interface (UEFI) (the default) boot mode is an enhanced 64-bit boot interface. If you have configured your system to boot to UEFI mode, it replaces the system BIOS.
1. From the **System Setup Main Menu**, click **Boot Settings**, and select **Boot Mode**.
 2. Select the boot mode you want the system to boot into.

 **CAUTION:** Switching the boot mode may prevent the system from booting if the operating system is not installed in the same boot mode.

3. After the system boots in the specified boot mode, proceed to install your operating system from that mode.

NOTE:

- Operating systems must be UEFI-compatible to be installed from the UEFI boot mode. DOS and 32-bit operating systems do not support UEFI and can only be installed from the BIOS boot mode.
- For the latest information about supported operating systems, go to Dell.com/ossupport.

Related references

[Boot Settings](#)

Related tasks

[Boot Settings details](#)

[Viewing Boot Settings](#)

Changing the boot order

You may have to change the boot order if you want to boot from a USB key or an optical drive. The following instructions may vary if you have selected **BIOS** for **Boot Mode**.

1. On the **System Setup Main Menu** screen, click **System BIOS > Boot Settings**.
2. Click **Boot Option Settings > Boot Sequence**.
3. Use the arrow keys to select a boot device, and use the plus (+) and minus (-) sign keys to move the device down or up in the order.
4. Click **Exit**, and then click **Yes** to save the settings on exit.

Related references

[Boot Settings](#)

Related tasks

[Boot Settings details](#)

[Viewing Boot Settings](#)

Network Settings

You can use the **Network Settings** screen to modify PXE device settings. The network settings option is available only in the UEFI mode.

 **NOTE:** The BIOS does not control network settings in the BIOS mode. For the BIOS boot mode, the optional Boot ROM of the network controllers handles the network settings.

Related concepts

[UEFI iSCSI Settings](#)

Related references

[Network Settings screen details](#)

[UEFI iSCSI Settings details](#)

[System BIOS](#)

Related tasks

[Viewing Network Settings](#)

[Viewing UEFI iSCSI Settings](#)

Viewing Network Settings

To view the **Network Settings** screen, perform the following steps:

1. Turn on, or restart your system.
2. Press F2 immediately after you see the following message:

```
F2 = System Setup
```

 **NOTE:** If your operating system begins to load before you press F2, wait for the system to finish booting, and then restart your system and try again.

3. On the **System Setup Main Menu** screen, click **System BIOS**.
4. On the **System BIOS** screen, click **Network Settings**.

Related references

[Network Settings](#)

[Network Settings screen details](#)

Network Settings screen details

The **Network Settings** screen details are explained as follows:

Option	Description
PXE Device n (n = 1 to 4)	Enables or disables the device. When enabled, a UEFI boot option is created for the device.
PXE Device n Settings(n = 1 to 4)	Enables you to control the configuration of the PXE device.

Related references

[Network Settings](#)

Related tasks

[Viewing Network Settings](#)

UEFI iSCSI Settings

You can use the iSCSI Settings screen to modify iSCSI device settings. The iSCSI Settings option is available only in the UEFI boot mode. BIOS does not control network settings in the BIOS boot mode. For the BIOS boot mode, the option ROM of the network controller handles the network settings.

Related references

[UEFI iSCSI Settings details](#)

Related tasks

[Viewing UEFI iSCSI Settings](#)

Viewing UEFI iSCSI Settings

To view the **UEFI iSCSI Settings** screen, perform the following steps:

1. Turn on, or restart your system.
2. Press F2 immediately after you see the following message:

```
F2 = System Setup
```

NOTE: If your operating system begins to load before you press F2, wait for the system to finish booting, and then restart your system and try again.

3. On the **System Setup Main Menu** screen, click **System BIOS**.
4. On the **System BIOS** screen, click **Network Settings**.
5. On the **Network Settings** screen, click **UEFI iSCSI Settings**.

Related references

[UEFI iSCSI Settings](#)

UEFI iSCSI Settings details

The **UEFI iSCSI Settings** screen details are explained as follows:

Option	Description
iSCSI Initiator Name	Specifies the name of the iSCSI initiator (iqn format).

Option	Description
ISCSI Device n (n = 1 to 4)	Enables or disables the iSCSI device. When disabled, a UEFI boot option is created for the iSCSI device automatically.

System Security

You can use the **System Security** screen to perform specific functions such as setting the system password, setup password and disabling the power button.

Related references

[Operating with a setup password enabled](#)
[System BIOS](#)

Related tasks

[System Security Settings details](#)
[Viewing System Security](#)
[Creating a system and setup password](#)
[Using your system password to secure your system](#)
[Deleting or changing system and setup password](#)

Viewing System Security

To view the **System Security** screen, perform the following steps:

1. Turn on, or restart your system.
2. Press F2 immediately after you see the following message:

```
F2 = System Setup
```

 **NOTE:** If your operating system begins to load before you press F2, wait for the system to finish booting, and then restart your system and try again.

3. On the **System Setup Main Menu** screen, click **System BIOS**.
4. On the **System BIOS** screen, click **System Security**.

Related references

[System Security](#)



Related tasks

[System Security Settings details](#)

System Security Settings details

The **System Security Settings** screen details are explained as follows:

Option	Description
Intel AES-NI	Improves the speed of applications by performing encryption and decryption by using the Advanced Encryption Standard Instruction Set (AES-NI). This option is set to Enabled by default.
System Password	Sets the system password. This option is set to Enabled by default and is read-only if the password jumper is not installed in the system.
Setup Password	Sets the setup password. This option is read-only if the password jumper is not installed in the system.
Password Status	Locks the system password. This option is set to Unlocked by default.

Option	Description
TPM Security	<p> NOTE: The TPM menu is available only when the TPM module is installed.</p> <p>Enables you to control the reporting mode of the TPM. The TPM Security option is set to Off by default. You can only modify the TPM Status, TPM Activation, and Intel TXT fields if the TPM Status field is set to either On with Pre-boot Measurements or On without Pre-boot Measurements.</p>
TPM Information	Changes the operational state of the TPM. This option is set to No Change by default.
TPM Status	Specifies the TPM status.
TPM Command	<p> CAUTION: Clearing the TPM results in the loss of all keys in the TPM. The loss of TPM keys may affect booting to the operating system.</p> <p>Clears all the contents of the TPM. The TPM Clear option is set to No by default.</p>
Intel TXT	Enables or disables the Intel Trusted Execution Technology (TXT) option. To enable the Intel TXT option, virtualization technology and TPM Security must be enabled with Pre-boot measurements. This option is set to Off by default.
Power Button	Enables or disables the power button on the front of the system. This option is set to Enabled by default.
NMI Button	Enables or disables the NMI button on the front of the system. This option is set to Disabled by default.
AC Power Recovery	Sets how the system behaves after AC power is restored to the system. This option is set to Last by default.
AC Power Recovery Delay	Sets the time delay for the system to power up after AC power is restored to the system. This option is set to Immediate by default.
User Defined Delay (60s to 240s)	Sets the User Defined Delay option when the User Defined option for AC Power Recovery Delay is selected.
UEFI Variable Access	Provides varying degrees of securing UEFI variables. When set to Standard (the default), UEFI variables are accessible in the operating system per the UEFI specification. When set to Controlled , selected UEFI variables are protected in the environment and new UEFI boot entries are forced to be at the end of the current boot order.
Secure Boot Policy	When Secure Boot policy is set to Standard , the BIOS uses the system manufacturer's key and certificates to authenticate pre-boot images. When Secure Boot policy is set to Custom , the BIOS uses the user-defined key and certificates. Secure Boot policy is set to Standard by default.
Secure Boot Policy Summary	Specifies the list of certificates and hashes that secure boot uses to authenticate images.

Related references

[System Security](#)

Related tasks

[Viewing System Security](#)

Secure Boot Custom Policy Settings

Secure Boot Custom Policy Settings is displayed only when **Secure Boot Policy** is set to **Custom**.

Viewing Secure Boot Custom Policy Settings

To view the **Secure Boot Custom Policy Settings** screen, perform the following steps:

1. Turn on, or restart your system.
2. Press F2 immediately after you see the following message:

```
F2 = System Setup
```

NOTE: If your operating system begins to load before you press F2, wait for the system to finish booting, and then restart your system and try again.

3. On the **System Setup Main Menu** screen, click **System BIOS**.
4. On the **System BIOS** screen, click **System Security**.
5. On the **System Security** screen, click **Secure Boot Custom Policy Settings**.

Secure Boot Custom Policy Settings details

The **Secure Boot Custom Policy Settings** screen details are explained as follows:

Option	Description
Platform Key	Imports, exports, deletes, or restores the platform key (PK).
Key Exchange Key Database	Enables you to import, export, delete, or restore entries in the Key Exchange Key (KEK) Database.
Authorized Signature Database	Imports, exports, deletes, or restores entries in the Authorized Signature Database (db).
Forbidden Signature Database	Imports, exports, deletes, or restores entries in the Forbidden Signature Database (dbx).

Creating a system and setup password

Ensure that the password jumper is enabled. The password jumper enables or disables the system password and setup password features. For more information, see the System board jumper settings section.

NOTE: If the password jumper setting is disabled, the existing system password and setup password are deleted and you need not provide the system password to boot the system.

1. To enter System Setup, press F2 immediately after turning on or rebooting your system.
2. On the **System Setup Main Menu** screen, click **System BIOS > System Security**.
3. On the **System Security** screen, verify that **Password Status** is set to **Unlocked**.
4. In the **System Password** field, type your system password, and press Enter or Tab.

Use the following guidelines to assign the system password:

- A password can have up to 32 characters.
- The password can contain the numbers 0 through 9.
- Only the following special characters are allowed: space, ("), (+), (,), (-), (.), (/), (;), ([], (\), (]), (`).

A message prompts you to reenter the system password.

5. Reenter the system password, and click **OK**.
6. In the **Setup Password** field, type your setup password and press Enter or Tab. A message prompts you to reenter the setup password.
7. Reenter the setup password, and click **OK**.
8. Press Esc to return to the System BIOS screen. Press Esc again. A message prompts you to save the changes.

NOTE: Password protection does not take effect until the system reboots.

Related references

[System board jumper settings](#)

[System board jumpers and connectors](#)

[System Security](#)

Using your system password to secure your system

If you have assigned a setup password, the system accepts your setup password as an alternate system password.

1. Turn on or reboot your system.
2. Type the system password and press Enter.

When **Password Status** is set to **Locked**, type the system password and press Enter when prompted at reboot.

i **NOTE:** If an incorrect system password is typed, the system displays a message and prompts you to reenter your password. You have three attempts to type the correct password. After the third unsuccessful attempt, the system displays an error message that the system has stopped functioning and must be turned off. Even after you turn off and restart the system, the error message is displayed until the correct password is entered.

Related references

[System Security](#)

Deleting or changing system and setup password

i **NOTE:** You cannot delete or change an existing system or setup password if the **Password Status** is set to **Locked**.

1. To enter System Setup, press F2 immediately after turning on or restarting your system.
2. On the **System Setup Main Menu** screen, click **System BIOS > System Security**.
3. On the **System Security** screen, ensure that **Password Status** is set to **Unlocked**.
4. In the **System Password** field, alter or delete the existing system password, and then press Enter or Tab.
5. In the **Setup Password** field, alter or delete the existing setup password, and then press Enter or Tab.
If you change the system and setup password, a message prompts you to reenter the new password. If you delete the system and setup password, a message prompts you to confirm the deletion.
6. Press Esc to return to the **System BIOS** screen. Press Esc again, and a message prompts you to save the changes.

Related references

[System Security](#)

Operating with a setup password enabled

If **Setup Password** is set to **Enabled**, type the correct setup password before modifying the system setup options.

If you do not type the correct password in three attempts, the system displays the following message:

```
Invalid Password! Number of unsuccessful password attempts: <x> System Halted! Must power down.
```

Even after you turn off and restart the system, the error message is displayed until the correct password is typed. The following options are exceptions:

- If **System Password** is not set to **Enabled** and is not locked through the **Password Status** option, you can assign a system password. For more information, see the System Security Settings screen section.
- You cannot disable or change an existing system password.

i **NOTE:** You can use the password status option with the setup password option to protect the system password from unauthorized changes.

Related references

[System Security](#)

Related tasks

[Viewing System Security](#)

System Information

You can use the **System Information** screen to view system properties such as Service Tag, system model name, and the BIOS version.

Related references

[System Information details](#)

[System BIOS](#)

Related tasks

[Viewing System Information](#)

Viewing System Information

To view the **System Information** screen, perform the following steps:

1. Turn on, or restart your system.
2. Press F2 immediately after you see the following message:

```
F2 = System Setup
```

 **NOTE:** If your operating system begins to load before you press F2, wait for the system to finish booting, and then restart your system and try again.

3. On the **System Setup Main Menu** screen, click **System BIOS**.
4. On the **System BIOS** screen, click **System Information**.

Related references

[System Information](#)

System Information details

The **System Information** screen details are explained as follows:

Option	Description
System Model Name	Specifies the system model name.
System BIOS Version	Specifies the BIOS version installed on the system.
System Management Engine Version	Specifies the current version of the Management Engine firmware.
System Service Tag	Specifies the system Service Tag.
System Manufacturer	Specifies the name of the system manufacturer.
System Manufacturer Contact Information	Specifies the contact information of the system manufacturer.
System CPLD Version	Specifies the current version of the system complex programmable logic device (CPLD) firmware.
UEFI Compliance Version	Specifies the UEFI compliance level of the system firmware.

Related references

[System Information](#)
[System Information details](#)

Related tasks

[Viewing System Information](#)

Memory Settings

You can use the **Memory Settings** screen to view all the memory settings and enable or disable specific memory functions, such as memory testing and node interleaving.

Related references

[Memory Settings details](#)
[System BIOS](#)

Related tasks

[Viewing Memory Settings](#)

Viewing Memory Settings

To view the **Memory Settings** screen, perform the following steps:

1. Turn on, or restart your system.
2. Press F2 immediately after you see the following message:

```
F2 = System Setup
```

 **NOTE:** If your operating system begins to load before you press F2, wait for the system to finish booting, and then restart your system and try again.

3. On the **System Setup Main Menu** screen, click **System BIOS**.
4. On the **System BIOS** screen, click **Memory Settings**.

Related references

[Memory Settings](#)
[Memory Settings details](#)

Memory Settings details

The **Memory Settings** screen details are explained as follows:

Option	Description
System Memory Size	Specifies the memory size in the system.
System Memory Type	Specifies the type of memory installed in the system.
System Memory Speed	Specifies the memory speed.
System Memory Voltage	Specifies the memory voltage.
Video Memory	Specifies the amount of video memory.

Option	Description
System Memory Testing	Specifies whether the memory tests are run during system boot. Options are Enabled and Disabled . This option is set to Disabled by default.
Memory Operating Mode	<p>Specifies the memory operating mode. The options available are Optimizer Mode, Advanced ECC Mode, Mirror Mode, Spare Mode, Spare with Advanced ECC Mode, Dell Fault Resilient Mode and Dell NUMA Fault Resilient Mode. This option is set to Optimizer Mode by default.</p> <p>NOTE: The Memory Operating Mode option can have different default and available options based on the memory configuration of your system.</p> <p>NOTE: The Dell Fault Resilient Mode option establishes an area of memory that is fault resilient. This mode can be used by an operating system that supports the feature to load critical applications or enables the operating system kernel to maximize system availability.</p>
Node Interleaving	Specifies if the Non-Uniform Memory Architecture (NUMA) is supported. If this field is set to Enabled , memory interleaving is supported if a symmetric memory configuration is installed. If the field is set to Disabled , the system supports NUMA (asymmetric) memory configurations. This option is set to Disabled by default.
Snoop Mode	Specifies the Snoop Mode options. The Snoop Mode options available are Home Snoop , Early Snoop , and Cluster on Die . This option is set to Early Snoop by default. This field is available only when the Node Interleaving is set to Disabled .

Related references

[Memory Settings](#)

Related tasks

[Viewing Memory Settings](#)

Processor Settings

You can use the **Processor Settings** screen to view the processor settings, and perform specific functions such as enabling virtualization technology, hardware prefetcher, and logical processor idling.

Related references

[Processor Settings details](#)

[System BIOS](#)

Related tasks

[Viewing Processor Settings](#)

Viewing Processor Settings

To view the **Processor Settings** screen, perform the following steps:

1. Turn on, or restart your system.
2. Press F2 immediately after you see the following message:

```
F2 = System Setup
```

NOTE: If your operating system begins to load before you press F2, wait for the system to finish booting, and then restart your system and try again.

3. On the **System Setup Main Menu** screen, click **System BIOS**.
4. On the **System BIOS** screen, click **Processor Settings**.





Related references

[Processor Settings](#)

[Processor Settings details](#)

Processor Settings details

The **Processor Settings** screen details are explained as follows:

Option	Description
Logical Processor	Enables or disables the logical processors and displays the number of logical processors. If this option is set to Enabled , the BIOS displays all the logical processors. If this option is set to Disabled , the BIOS displays only one logical processor per core. This option is set to Enabled by default.
QPI Speed	Enables you to control QuickPath Interconnect data rate settings.
Alternate RTID (Requestor Transaction ID) Setting	Modifies Requestor Transaction IDs, which are QPI resources. This option is set to Disabled by default.  NOTE: Enabling this option may negatively impact the overall system performance.
Virtualization Technology	Enables or disables the additional hardware capabilities provided for virtualization. This option is set to Enabled by default.
Address Translation Service (ATS)	Defines the Address Translation Cache (ATC) for devices to cache the DMA transactions. This option provides an interface between CPU and DMA Memory Management to a chipset's Address Translation and Protection Table to translate DMA addresses to host addresses. This option is set to Enabled by default.
Adjacent Cache Line Prefetch	Optimizes the system for applications that need high utilization of sequential memory access. This option is set to Enabled by default. You can disable this option for applications that need high utilization of random memory access.
Hardware Prefetcher	Enables or disables the hardware prefetcher. This option is set to Enabled by default.
DCU Streamer Prefetcher	Enables or disables the Data Cache Unit (DCU) streamer prefetcher. This option is set to Enabled by default.
DCU IP Prefetcher	Enables or disables the Data Cache Unit (DCU) IP prefetcher. This option is set to Enabled by default.
Logical Processor Idling	Enables you to improve the energy efficiency of a system. It uses the operating system core parking algorithm and parks some of the logical processors in the system which in turn allows the corresponding processor cores to transition into a lower power idle state. This option can only be enabled if the operating system supports it. It is set to Disabled by default.
Configurable TDP	Enables you to reconfigure the processor Thermal Design Power (TDP) levels during POST based on the power and thermal delivery capabilities of the system. TDP verifies the maximum heat the cooling system is needed to dissipate. This option is set to Nominal by default.  NOTE: This option is only available on certain stock keeping units (SKUs) of the processors.
X2Apic Mode	Enables or disables the X2Apic mode.
Dell Controlled Turbo	Controls the turbo engagement. Enable this option only when System Profile is set to Performance .  NOTE: Depending on the number of installed CPUs, there may be up to four processor listings.
Number of Cores per Processor	Controls the number of enabled cores in each processor. This option is set to All by default.
Processor 64-bit Support	Specifies if the processor(s) support 64-bit extensions.
Processor Core Speed	Specifies the maximum core frequency of the processor.
Processor 1	 NOTE: Depending on the number of CPUs, there may be up to four processors listed.

Option Description

The following settings are displayed for each processor installed in the system:

Option	Description
Family-Model-Stepping	Specifies the family, model, and stepping of the processor as defined by Intel.
Brand	Specifies the brand name.
Level 2 Cache	Specifies the total L2 cache.
Level 3 Cache	Specifies the total L3 cache.
Number of Cores	Specifies the number of cores per processor.

Related references

[Processor Settings](#)

Related tasks

[Viewing Processor Settings](#)

SATA Settings

You can use the **SATA Settings** screen to view the SATA settings of SATA devices and enable RAID on your system.

Related references

[System BIOS](#)

Related tasks

[SATA Settings details](#)

[Viewing SATA Settings](#)

Viewing SATA Settings

To view the **SATA Settings** screen, perform the following steps:

1. Turn on, or restart your system.
2. Press F2 immediately after you see the following message:

```
F2 = System Setup
```

 **NOTE:** If your operating system begins to load before you press F2, wait for the system to finish booting, and then restart your system and try again.

3. On the **System Setup Main Menu** screen, click **System BIOS**.
4. On the **System BIOS** screen, click **SATA Settings**.

Related references

[SATA Settings](#)

Related tasks

[SATA Settings details](#)

SATA Settings details

The **SATA Settings** screen details are explained as follows:

Option	Description								
Embedded SATA	Enables the embedded SATA option to be set to Off , ATA , AHCI , or RAID modes. This option is set to AHCI by default.								
Security Freeze Lock	Sends Security Freeze Lock command to the Embedded SATA drives during POST. This option is applicable only for ATA and AHCI modes.								
Write Cache	Enables or disables the command for Embedded SATA drives during POST.								
Port A	<p>Sets the drive type of the selected device. For Embedded SATA settings in ATA mode, set this field to Auto to enable BIOS support. Set it to OFF to turn off BIOS support.</p> <p>For AHCI or RAID mode, BIOS support is always enabled.</p> <table border="0" style="margin-left: 20px;"> <thead> <tr> <th style="text-align: left;">Option</th> <th style="text-align: left;">Description</th> </tr> </thead> <tbody> <tr> <td>Model</td> <td>Specifies the drive model of the selected device.</td> </tr> <tr> <td>Drive Type</td> <td>Specifies the type of drive attached to the SATA port.</td> </tr> <tr> <td>Capacity</td> <td>Specifies the total capacity of the hard drive. This field is undefined for removable media devices such as optical drives.</td> </tr> </tbody> </table>	Option	Description	Model	Specifies the drive model of the selected device.	Drive Type	Specifies the type of drive attached to the SATA port.	Capacity	Specifies the total capacity of the hard drive. This field is undefined for removable media devices such as optical drives.
Option	Description								
Model	Specifies the drive model of the selected device.								
Drive Type	Specifies the type of drive attached to the SATA port.								
Capacity	Specifies the total capacity of the hard drive. This field is undefined for removable media devices such as optical drives.								
Port B	<p>Sets the drive type of the selected device. For Embedded SATA settings in ATA mode, set this field to Auto to enable BIOS support. Set it to OFF to turn off BIOS support.</p> <p>For AHCI or RAID mode, BIOS support is always enabled.</p> <table border="0" style="margin-left: 20px;"> <thead> <tr> <th style="text-align: left;">Option</th> <th style="text-align: left;">Description</th> </tr> </thead> <tbody> <tr> <td>Model</td> <td>Specifies the drive model of the selected device.</td> </tr> <tr> <td>Drive Type</td> <td>Specifies the type of drive attached to the SATA port.</td> </tr> <tr> <td>Capacity</td> <td>Specifies the total capacity of the hard drive. This field is undefined for removable media devices such as optical drives.</td> </tr> </tbody> </table>	Option	Description	Model	Specifies the drive model of the selected device.	Drive Type	Specifies the type of drive attached to the SATA port.	Capacity	Specifies the total capacity of the hard drive. This field is undefined for removable media devices such as optical drives.
Option	Description								
Model	Specifies the drive model of the selected device.								
Drive Type	Specifies the type of drive attached to the SATA port.								
Capacity	Specifies the total capacity of the hard drive. This field is undefined for removable media devices such as optical drives.								
Port C	<p>Sets the drive type of the selected device. For Embedded SATA settings in ATA mode, set this field to Auto to enable BIOS support. Set it to OFF to turn off BIOS support.</p> <p>For AHCI or RAID mode, BIOS support is always enabled.</p> <table border="0" style="margin-left: 20px;"> <thead> <tr> <th style="text-align: left;">Option</th> <th style="text-align: left;">Description</th> </tr> </thead> <tbody> <tr> <td>Model</td> <td>Specifies the drive model of the selected device.</td> </tr> <tr> <td>Drive Type</td> <td>Specifies the type of drive attached to the SATA port.</td> </tr> <tr> <td>Capacity</td> <td>Specifies the total capacity of the hard drive. This field is undefined for removable media devices such as optical drives.</td> </tr> </tbody> </table>	Option	Description	Model	Specifies the drive model of the selected device.	Drive Type	Specifies the type of drive attached to the SATA port.	Capacity	Specifies the total capacity of the hard drive. This field is undefined for removable media devices such as optical drives.
Option	Description								
Model	Specifies the drive model of the selected device.								
Drive Type	Specifies the type of drive attached to the SATA port.								
Capacity	Specifies the total capacity of the hard drive. This field is undefined for removable media devices such as optical drives.								
Port D	<p>Sets the drive type of the selected device. For Embedded SATA settings in ATA mode, set this field to Auto to enable BIOS support. Set it to OFF to turn off BIOS support.</p> <p>For AHCI or RAID mode, BIOS support is always enabled.</p> <table border="0" style="margin-left: 20px;"> <thead> <tr> <th style="text-align: left;">Option</th> <th style="text-align: left;">Description</th> </tr> </thead> <tbody> <tr> <td>Model</td> <td>Specifies the drive model of the selected device.</td> </tr> <tr> <td>Drive Type</td> <td>Specifies the type of drive attached to the SATA port.</td> </tr> <tr> <td>Capacity</td> <td>Specifies the total capacity of the hard drive. This field is undefined for removable media devices such as optical drives.</td> </tr> </tbody> </table>	Option	Description	Model	Specifies the drive model of the selected device.	Drive Type	Specifies the type of drive attached to the SATA port.	Capacity	Specifies the total capacity of the hard drive. This field is undefined for removable media devices such as optical drives.
Option	Description								
Model	Specifies the drive model of the selected device.								
Drive Type	Specifies the type of drive attached to the SATA port.								
Capacity	Specifies the total capacity of the hard drive. This field is undefined for removable media devices such as optical drives.								
Port E	<p>Sets the drive type of the selected device. For Embedded SATA settings in ATA mode, set this field to Auto to enable BIOS support. Set it to OFF to turn off BIOS support.</p> <p>For AHCI or RAID mode, BIOS support is always enabled.</p>								

Option	Description								
	<table border="0"> <thead> <tr> <th style="text-align: left;">Option</th> <th style="text-align: left;">Description</th> </tr> </thead> <tbody> <tr> <td>Model</td> <td>Specifies the drive model of the selected device.</td> </tr> <tr> <td>Drive Type</td> <td>Specifies the type of drive attached to the SATA port.</td> </tr> <tr> <td>Capacity</td> <td>Specifies the total capacity of the hard drive. This field is undefined for removable media devices such as optical drives.</td> </tr> </tbody> </table>	Option	Description	Model	Specifies the drive model of the selected device.	Drive Type	Specifies the type of drive attached to the SATA port.	Capacity	Specifies the total capacity of the hard drive. This field is undefined for removable media devices such as optical drives.
Option	Description								
Model	Specifies the drive model of the selected device.								
Drive Type	Specifies the type of drive attached to the SATA port.								
Capacity	Specifies the total capacity of the hard drive. This field is undefined for removable media devices such as optical drives.								
Port F	<p>Sets the drive type of the selected device. For Embedded SATA settings in ATA mode, set this field to Auto to enable BIOS support. Set it to OFF to turn off BIOS support.</p> <p>For AHCI or RAID mode, BIOS support is always enabled.</p> <table border="0"> <thead> <tr> <th style="text-align: left;">Option</th> <th style="text-align: left;">Description</th> </tr> </thead> <tbody> <tr> <td>Model</td> <td>Specifies the drive model of the selected device.</td> </tr> <tr> <td>Drive Type</td> <td>Specifies the type of drive attached to the SATA port.</td> </tr> <tr> <td>Capacity</td> <td>Specifies the total capacity of the hard drive. This field is undefined for removable media devices such as optical drives.</td> </tr> </tbody> </table>	Option	Description	Model	Specifies the drive model of the selected device.	Drive Type	Specifies the type of drive attached to the SATA port.	Capacity	Specifies the total capacity of the hard drive. This field is undefined for removable media devices such as optical drives.
Option	Description								
Model	Specifies the drive model of the selected device.								
Drive Type	Specifies the type of drive attached to the SATA port.								
Capacity	Specifies the total capacity of the hard drive. This field is undefined for removable media devices such as optical drives.								
Port G	<p>Sets the drive type of the selected device. For Embedded SATA settings in ATA mode, set this field to Auto to enable BIOS support. Set it to OFF to turn off BIOS support.</p> <p>For AHCI or RAID mode, BIOS support is always enabled.</p> <table border="0"> <thead> <tr> <th style="text-align: left;">Option</th> <th style="text-align: left;">Description</th> </tr> </thead> <tbody> <tr> <td>Model</td> <td>Specifies the drive model of the selected device.</td> </tr> <tr> <td>Drive Type</td> <td>Specifies the type of drive attached to the SATA port.</td> </tr> <tr> <td>Capacity</td> <td>Specifies the total capacity of the hard drive. This field is undefined for removable media devices such as optical drives.</td> </tr> </tbody> </table>	Option	Description	Model	Specifies the drive model of the selected device.	Drive Type	Specifies the type of drive attached to the SATA port.	Capacity	Specifies the total capacity of the hard drive. This field is undefined for removable media devices such as optical drives.
Option	Description								
Model	Specifies the drive model of the selected device.								
Drive Type	Specifies the type of drive attached to the SATA port.								
Capacity	Specifies the total capacity of the hard drive. This field is undefined for removable media devices such as optical drives.								
Port H	<p>Sets the drive type of the selected device. For Embedded SATA settings in ATA mode, set this field to Auto to enable BIOS support. Set it to OFF to turn off BIOS support.</p> <p>For AHCI or RAID mode, BIOS support is always enabled.</p> <table border="0"> <thead> <tr> <th style="text-align: left;">Option</th> <th style="text-align: left;">Description</th> </tr> </thead> <tbody> <tr> <td>Model</td> <td>Specifies the drive model of the selected device.</td> </tr> <tr> <td>Drive Type</td> <td>Specifies the type of drive attached to the SATA port.</td> </tr> <tr> <td>Capacity</td> <td>Specifies the total capacity of the hard drive. This field is undefined for removable media devices such as optical drives.</td> </tr> </tbody> </table>	Option	Description	Model	Specifies the drive model of the selected device.	Drive Type	Specifies the type of drive attached to the SATA port.	Capacity	Specifies the total capacity of the hard drive. This field is undefined for removable media devices such as optical drives.
Option	Description								
Model	Specifies the drive model of the selected device.								
Drive Type	Specifies the type of drive attached to the SATA port.								
Capacity	Specifies the total capacity of the hard drive. This field is undefined for removable media devices such as optical drives.								
Port I	<p>Sets the drive type of the selected device. For Embedded SATA settings in ATA mode, set this field to Auto to enable BIOS support. Set it to OFF to turn off BIOS support.</p> <p>For AHCI or RAID mode, BIOS support is always enabled.</p> <table border="0"> <thead> <tr> <th style="text-align: left;">Option</th> <th style="text-align: left;">Description</th> </tr> </thead> <tbody> <tr> <td>Model</td> <td>Specifies the drive model of the selected device.</td> </tr> <tr> <td>Drive Type</td> <td>Specifies the type of drive attached to the SATA port.</td> </tr> <tr> <td>Capacity</td> <td>Specifies the total capacity of the hard drive. This field is undefined for removable media devices such as optical drives.</td> </tr> </tbody> </table>	Option	Description	Model	Specifies the drive model of the selected device.	Drive Type	Specifies the type of drive attached to the SATA port.	Capacity	Specifies the total capacity of the hard drive. This field is undefined for removable media devices such as optical drives.
Option	Description								
Model	Specifies the drive model of the selected device.								
Drive Type	Specifies the type of drive attached to the SATA port.								
Capacity	Specifies the total capacity of the hard drive. This field is undefined for removable media devices such as optical drives.								
Port J	<p>Sets the drive type of the selected device. For Embedded SATA settings in ATA mode, set this field to Auto to enable BIOS support. Set it to OFF to turn off BIOS support.</p> <p>For AHCI or RAID mode, BIOS support is always enabled.</p>								

Option	Description
Option	Description
Model	Specifies the drive model of the selected device.
Drive Type	Specifies the type of drive attached to the SATA port.
Capacity	Specifies the total capacity of the hard drive. This field is undefined for removable media devices such as optical drives.

Related references

[SATA Settings](#)

Related tasks

[Viewing SATA Settings](#)

Integrated Devices

You can use the **Integrated Devices** screen to view and configure the settings of all integrated devices including the video controller, integrated RAID controller, and the USB ports.

Related references

[System BIOS](#)

Related tasks

[Integrated Devices details](#)

[Viewing Integrated Devices](#)

Viewing Integrated Devices

To view the **Integrated Devices** screen, perform the following steps:

1. Turn on, or restart your system.
2. Press F2 immediately after you see the following message:

```
F2 = System Setup
```

 **NOTE:** If your operating system begins to load before you press F2, wait for the system to finish booting, and then restart your system and try again.

3. On the **System Setup Main Menu** screen, click **System BIOS**.
4. On the **System BIOS** screen, click **Integrated Devices**.

Related references



[Integrated Devices](#)





Related tasks

[Integrated Devices details](#)

Integrated Devices details

The **Integrated Devices** screen details are explained as follows:

Option	Description				
USB 3.0 Setting	Enables or disables the USB 3.0 support. Enable this option only if your operating system supports USB 3.0. If you disable this option, devices operate at USB 2.0 speed. USB 3.0 is enabled by default.				
User Accessible USB Ports	Enables or disables the USB ports. Selecting Only Back Ports On disables the front USB ports, selecting All Ports Off disables all USB ports. The USB keyboard and mouse operate during boot process in certain operating systems. After the boot process is complete, the USB keyboard and mouse do not work if the ports are disabled.  NOTE: Selecting Only Back Ports On and All Ports Off disables the USB management port and also restricts access to iDRAC features.				
Internal USB Port	Enables or disables the internal USB port. This option is set to Enabled by default.				
Integrated RAID Controller	Enables or disables the integrated RAID controller. This option is set to Enabled by default.				
Integrated Network Card 1	Enables or disables the integrated network card.				
Embedded NIC1 and NIC2	 NOTE: The Embedded NIC1 and NIC2 options are only available on systems that do not have Integrated Network Card 1 . Enables or disables the Embedded NIC1 and NIC2 options. If set to Disabled , the NIC may still be available for shared network access by the embedded management controller. The embedded NIC1 and NIC2 options are only available on systems that do not have Network Daughter Cards (NDCs). The Embedded NIC1 and NIC2 option is mutually exclusive with the Integrated Network Card 1 option. Configure the Embedded NIC1 and NIC2 option by using the NIC management utilities of the system.				
I/OAT DMA Engine	Enables or disables the I/OAT option. Enable only if the hardware and software support the feature.				
I/O Snoop Holdoff Response	Selects the number of cycles PCI I/O can withhold snoop requests from the CPU, to allow time to complete its own write to LLC. This setting can help improve performance on workloads where throughput and latency are critical.				
Embedded Video Controller	Enables or disables the Embedded Video Controller option. This option is set to Enabled by default.				
Current State of Embedded Video Controller	Displays the current state of the embedded video controller. The Current State of Embedded Video Controller option is a read-only field. If the Embedded Video Controller is the only display capability in the system (that is, no add-in graphics card is installed), then the Embedded Video Controller is automatically used as the primary display even if the Embedded Video Controller setting is set to Disabled .				
SR-IOV Global Enable	Enables or disables the BIOS configuration of Single Root I/O Virtualization (SR-IOV) devices. This option is set to Disabled by default.				
OS Watchdog Timer	If your system stops responding, this watchdog timer aids in the recovery of your operating system. When this option is set to Enabled , the operating system initializes the timer. When this option is set to Disabled (the default), the timer does not have any effect on the system.				
Memory Mapped I/O above 4 GB	Enables or disables the support for PCIe devices that need large amounts of memory. This option is set to Enabled by default.				
Slot Disablement	Enables or disables the available PCIe slots on your system. The slot disablement feature controls the configuration of PCIe cards installed in the specified slot. Slots must be disabled only when the installed peripheral card prevents booting into the operating system or causes delays in system startup. If the slot is disabled, both the Option ROM and UEFI drivers are disabled.				
Slot Bifurcation	Enables you to control the bifurcation of the specified slot. Only slots that are present in your system are available for control. The configuration for a x16 slot is default (x16), x8x8, or x4x4x4x4. The configuration for a x8 slot is default (x8) or x4x4.				
	<table border="1"> <thead> <tr> <th>Slots</th> <th>Description</th> </tr> </thead> <tbody> <tr> <td>Slot 1 Bifurcation</td> <td>Controls the bifurcation of PCIe cards installed in the specified slot.</td> </tr> </tbody> </table>	Slots	Description	Slot 1 Bifurcation	Controls the bifurcation of PCIe cards installed in the specified slot.
Slots	Description				
Slot 1 Bifurcation	Controls the bifurcation of PCIe cards installed in the specified slot.				

Option	Description
Slots	<p>Description</p> <p> NOTE: This slot bifurcation is supported in both two and three slot systems.</p> <ul style="list-style-type: none"> • When set to default, the slot operates at the default bifurcation for that slot. • When set to x8x8 or x4x4x4x4, the slot bifurcates to either two or four links depending on the slot capability.
Slot 2 Bifurcation	<p>Controls the bifurcation of PCIe cards installed in the specified slot.</p> <p> NOTE: This slot bifurcation is supported only in two slot systems.</p> <ul style="list-style-type: none"> • When set to default, the slot operates at the default bifurcation for that slot. • When set to x8x8 or x4x4x4x4 the slot bifurcates to either two or four links depending on the slot capability. <p> NOTE: This slot bifurcation is supported only in three slot systems.</p> <ul style="list-style-type: none"> • When set to x4x4 the slot bifurcates to two links.
Slot 3 Bifurcation	<p>Controls the bifurcation of PCIe cards installed in the specified slot.</p> <p> NOTE: This slot bifurcation is supported only in three slot systems.</p> <ul style="list-style-type: none"> • When set to default, the slot operates at the default bifurcation for that slot. • When set to x8x8 or x4x4x4x4, the slot bifurcates to either two or four links depending on the slot capability.

Related references

[Integrated Devices](#)

Related tasks

[Viewing Integrated Devices](#)

Serial Communication

You can use the **Serial Communication** screen to view the properties of the serial communication port.

Related references

[System BIOS](#)

Related tasks

[Serial Communication details](#)

[Viewing Serial Communication](#)

Viewing Serial Communication

To view the **Serial Communication** screen, perform the following steps:

1. Turn on, or restart your system.
2. Press F2 immediately after you see the following message:

```
F2 = System Setup
```

 **NOTE:** If your operating system begins to load before you press F2, wait for the system to finish booting, and then restart your system and try again.

3. On the **System Setup Main Menu** screen, click **System BIOS**.
4. On the **System BIOS** screen, click **Serial Communication**.

Related references

[Serial Communication](#)

Related tasks

[Serial Communication details](#)

Serial Communication details

The **Serial Communication** screen details are explained as follows:

Option	Description
Serial Communication	Selects serial communication devices (Serial Device 1 and Serial Device 2) in BIOS. BIOS console redirection can also be enabled and the port address can be specified. This option is set to Auto by default.
Serial Port Address	Enables you to set the port address for serial devices. This option is set to Serial Device 1=COM2, Serial Device 2=COM1 by default. <i>i</i> NOTE: You can use only Serial Device 2 for the Serial Over LAN (SOL) feature. To use console redirection by SOL, configure the same port address for console redirection and the serial device. <i>i</i> NOTE: Every time the system boots, the BIOS syncs the serial MUX setting saved in iDRAC. The serial MUX setting can independently be changed in iDRAC. Loading the BIOS default settings from within the BIOS setup utility may not always revert the serial MUX setting to the default setting of Serial Device 1.
External Serial Connector	Enables you to associate the External Serial Connector to Serial Device 1, Serial Device 2, or the Remote Access Device by using this option. <i>i</i> NOTE: Only Serial Device 2 can be used for Serial Over LAN (SOL). To use console redirection by SOL, configure the same port address for console redirection and the serial device. <i>i</i> NOTE: Every time the system boots, the BIOS syncs the serial MUX setting saved in iDRAC. The serial MUX setting can independently be changed in iDRAC. Loading the BIOS default settings from within the BIOS setup utility may not always revert this setting to the default setting of Serial Device 1.
Failsafe Baud Rate	Specifies the failsafe baud rate for console redirection. The BIOS attempts to determine the baud rate automatically. This failsafe baud rate is used only if the attempt fails, and the value must not be changed. This option is set to 115200 by default.
Remote Terminal Type	Sets the remote console terminal type. This option is set to vT 100/vT 220 by default.
Redirection After Boot	Enables or disables the BIOS console redirection when the operating system is loaded. This option is set to Enabled by default.

Related references

[Serial Communication](#)

Related tasks

[Viewing Serial Communication](#)

System Profile Settings

You can use the **System Profile Settings** screen to enable specific system performance settings such as power management.

Related references

[System BIOS](#)

Related tasks

[System Profile Settings details](#)

[Viewing System Profile Settings](#)

Viewing System Profile Settings

To view the **System Profile Settings** screen, perform the following steps:

1. Turn on, or restart your system.
2. Press F2 immediately after you see the following message:

```
F2 = System Setup
```

NOTE: If your operating system begins to load before you press F2, wait for the system to finish booting, and then restart your system and try again.

3. On the **System Setup Main Menu** screen, click **System BIOS**.
4. On the **System BIOS** screen, click **System Profile Settings**.

Related references

[System Profile Settings](#)



Related tasks

[System Profile Settings details](#)

System Profile Settings details

The **System Profile Settings** screen details are explained as follows:

Option	Description
System Profile	Sets the system profile. If you set the System Profile option to a mode other than Custom , the BIOS automatically sets the rest of the options. You can only change the rest of the options if the mode is set to Custom . This option is set to Performance Per Watt Optimized (DAPC) by default. DAPC is Dell Active Power Controller. NOTE: All the parameters on the system profile setting screen are available only when the System Profile option is set to Custom .
CPU Power Management	Sets the CPU power management. This option is set to System DBPM (DAPC) by default.
Memory Frequency	Sets the speed of the memory. You can select Maximum Performance , Maximum Reliability , or a specific speed.
Turbo Boost	Enables or disables the processor to operate in the turbo boost mode. This option is set to Enabled by default.
Energy Efficient Turbo	Enables or disables the Energy Efficient Turbo option. Energy Efficient Turbo (EET) is a mode of operation where a processor's core frequency is adjusted to be within the turbo range based on workload.

Option	Description
C1E	Enables or disables the processor to switch to a minimum performance state when it is idle. This option is set to Enabled by default.
C States	Enables or disables the processor to operate in all available power states. This option is set to Enabled by default.
Collaborative CPU Performance Control	Enables or disables the CPU power management option. When set to Enabled , the CPU power management is controlled by the OS DBPM and the System DBPM (DAPC). This option is set to Disabled by default.
Memory Patrol Scrub	Sets the memory patrol scrub frequency. This option is set to Standard by default.
Memory Refresh Rate	Sets the memory refresh rate to either 1x or 2x. This option is set to 1x by default.
Uncore Frequency	Enables you to select the Processor Uncore Frequency option. Dynamic mode enables the processor to optimize power resources across the cores and uncore during runtime. The optimization of the uncore frequency to either save power or optimize performance is influenced by the setting of the Energy Efficiency Policy option.
Energy Efficient Policy	Enables you to select the Energy Efficient Policy option. The CPU uses the setting to manipulate the internal behavior of the processor and determines whether to target higher performance or better power savings.
Number of Turbo Boost Enabled Cores for Processor 1	 NOTE: If there are two processors installed in the system, you see an entry for Number of Turbo Boost Enabled Cores for Processor 2 . Controls the number of turbo boost enabled cores for processor 1. The maximum number of cores is enabled by default.
Monitor/Mwait	Enables the Monitor/Mwait instructions in the processor. This option is set to Enabled for all system profiles, except Custom by default.  NOTE: This option can be disabled only if the C States option in the Custom mode is set to disabled .  NOTE: When C States is set to Enabled in the Custom mode, changing the Monitor/Mwait setting does not impact the system power or performance.

Related references

[System Profile Settings](#)

Related tasks

[Viewing System Profile Settings](#)

Miscellaneous Settings

You can use the **Miscellaneous Settings** screen to perform specific functions such as updating the asset tag and changing the system date and time.

Related references

[System BIOS](#)

Related tasks

[Miscellaneous Settings details](#)

[Viewing Miscellaneous Settings](#)

Viewing Miscellaneous Settings

To view the **Miscellaneous Settings** screen, perform the following steps:

1. Turn on, or restart your system.
2. Press F2 immediately after you see the following message:

```
F2 = System Setup
```

NOTE: If your operating system begins to load before you press F2, wait for the system to finish booting, and then restart your system and try again.

3. On the **System Setup Main Menu** screen, click **System BIOS**.
4. On the **System BIOS** screen, click **Miscellaneous Settings**.

Related references

[Miscellaneous Settings](#)

Related tasks

[Miscellaneous Settings details](#)

Miscellaneous Settings details

The **Miscellaneous Settings** screen details are explained as follows:

Option	Description
System Time	Enables you to set the time on the system.
System Date	Enables you to set the date on the system.
Asset Tag	Specifies the asset tag and enables you to modify it for security and tracking purposes.
Keyboard NumLock	Enables you to set whether the system boots with the NumLock enabled or disabled. This option is set to On by default. NOTE: This option does not apply to 84-key keyboards.
F1/F2 Prompt on Error	Enables or disables the F1/F2 prompt on error. This option is set to Enabled by default. The F1/F2 prompt also includes keyboard errors.
Load Legacy Video Option ROM	Enables you to determine whether the system BIOS loads the legacy video (INT 10H) option ROM from the video controller. Selecting Enabled in the operating system does not support UEFI video output standards. This field is available only for UEFI boot mode. You cannot set the option to Enabled if UEFI Secure Boot mode is enabled.

Related references

[Miscellaneous Settings](#)

Related tasks

[Viewing Miscellaneous Settings](#)

iDRAC Settings utility

The iDRAC settings utility is an interface to set up and configure the iDRAC parameters by using UEFI. You can enable or disable various iDRAC parameters by using the iDRAC settings utility.

NOTE: Accessing some of the features on the iDRAC settings utility needs the iDRAC Enterprise License upgrade.

For more information about using iDRAC, see *Dell Integrated Dell Remote Access Controller User's Guide* at Dell.com/idracmanuals.

Related concepts

[Device Settings](#)

Related references

[System BIOS](#)

Related tasks

[Entering the iDRAC Settings utility](#)

[Changing the thermal settings](#)

Entering the iDRAC Settings utility

1. Turn on or restart the managed system.
2. Press F2 during Power-on Self-test (POST).
3. On the **System Setup Main Menu** page, click **iDRAC Settings**.
The **iDRAC Settings** screen is displayed.

Related references

[iDRAC Settings utility](#)

Changing the thermal settings

The iDRAC settings utility enables you to select and customize the thermal control settings for your system.

1. Click **iDRAC Settings > Thermal**.
2. Under **SYSTEM THERMAL PROFILE > Thermal Profile**, select one of the following options:
 - Default Thermal Profile Settings
 - Maximum Performance (Performance Optimized)
 - Minimum Power (Performance per Watt Optimized)
3. Under **USER COOLING OPTIONS**, set the **Fan Speed Offset**, **Minimum Fan Speed**, and **Custom Minimum Fan Speed**.
4. Click **Back > Finish > Yes**.

Related references

[iDRAC Settings utility](#)

Device Settings

Device Settings enables you to configure device parameters.

Related references

[System BIOS](#)

Dell Lifecycle Controller

Dell Lifecycle Controller (LC) provides advanced embedded system management capabilities including system deployment, configuration, update, maintenance, and diagnosis. LC is delivered as part of the iDRAC out-of-band solution and Dell EMC system embedded Unified Extensible Firmware Interface (UEFI) applications.

Related references

[Embedded systems management](#)

Embedded systems management

The Dell Lifecycle Controller provides advanced embedded systems management throughout the lifecycle of the system. The Dell Lifecycle Controller can be started during the boot sequence and can function independently of the operating system.

 **NOTE:** Certain platform configurations may not support the full set of features provided by the Dell Lifecycle Controller.

For more information about setting up the Dell Lifecycle Controller, configuring hardware and firmware, and deploying the operating system, see the Dell Lifecycle Controller documentation at Dell.com/idracmanuals.

Related references

[Dell Lifecycle Controller](#)

Boot Manager

The **Boot Manager** screen enables you to select boot options and diagnostic utilities.

Related references

[Boot Manager main menu](#)
[System BIOS](#)

Related tasks

[Viewing Boot Manager](#)

Viewing Boot Manager

To enter **Boot Manager**:

1. Turn on, or restart your system.
2. Press F11 when you see the following message:

```
F11 = Boot Manager
```

If your operating system begins to load before you press F11, allow the system to complete the booting, and then restart your system and try again.

Related references

[Boot Manager](#)
[Boot Manager main menu](#)

Boot Manager main menu

Menu item	Description
Continue Normal Boot	The system attempts to boot to devices starting with the first item in the boot order. If the boot attempt fails, the system continues with the next item in the boot order until the boot is successful or no more boot options are found.
One-shot Boot Menu	Enables you to access boot menu, where you can select a one-time boot device to boot from.
Launch System Setup	Enables you to access System Setup.
Launch Lifecycle Controller	Exits the Boot Manager and invokes the Dell Lifecycle Controller program.

Menu item	Description
-----------	-------------

System Utilities	Enables you to launch System Utilities menu such as System Diagnostics and UEFI shell.
-------------------------	--

Related references

[Boot Manager](#)

Related tasks

[Viewing Boot Manager](#)

One-shot BIOS boot menu

One-shot BIOS boot menu enables you to select a boot device to boot from.

Related references

[Boot Manager](#)

System Utilities

System Utilities contains the following utilities that can be launched:

- Launch Diagnostics
- BIOS/UEFI Update File Explorer
- Reboot System

 **NOTE:** Depending on the boot mode selected, you might have BIOS or UEFI Update File Explorer.

Related references

[Boot Manager](#)

PXE boot

You can use the Preboot Execution Environment (PXE) option to boot and configure the networked systems, remotely.

 **NOTE:** To access the **PXE boot** option, boot the system and then press F12. The system scans and displays the active networked systems.

Installing and removing system components

Topics:

- Safety instructions
- Before working inside your system
- After working inside your system
- Recommended tools
- Front bezel (optional)
- System cover
- Inside the system
- Cooling shroud
- System memory
- Hard drives
- Optical drive (optional)
- Cooling fans
- Internal USB memory key (optional)
- Expansion cards and expansion card riser
- SD vFlash card (optional)
- IDSDM
- Integrated storage controller card
- Network daughter card
- Processors and heat sinks
- Power supply units (PSU)
- System battery
- Hard drive backplane
- Control panel assembly
- VGA module
- System board
- Trusted Platform Module

Safety instructions

 **NOTE:** Whenever you need to lift the system, get others to assist you. To avoid injury, do not attempt to lift the system by yourself.

 **WARNING:** Opening or removing the system cover while the system is powered on may expose you to a risk of electric shock.

 **CAUTION:** Do not operate the system without the cover for a duration exceeding five minutes.

 **CAUTION:** Many repairs may only be done by a certified service technician. You should only perform troubleshooting and simple repairs as authorized in your product documentation, or as directed by the online or telephone service and support team. Damage due to servicing that is not authorized by Dell is not covered by your warranty. Read and follow the safety instructions that are shipped with your product.

 **NOTE:** It is recommended that you always use an antistatic mat and antistatic strap while working on components inside the system.

 **NOTE:** To ensure proper operation and cooling, all bays in the system and system fans must be populated always with either a component or with a blank.

Before working inside your system

Follow the safety guidelines listed in the Safety instructions section.

1. Turn off the system, including any attached peripherals.
2. Disconnect the system from the electrical outlet and disconnect the peripherals.
3. If installed, remove the front bezel.
4. If applicable, remove the system from the rack.
For more information, see the *Rack Installation* placemat at Dell.com/poweredgemanuals.
5. Remove the system cover.

Related references

[Safety instructions](#)

Related tasks

[Removing the system cover](#)

[Removing the optional front bezel](#)

After working inside your system

Follow the safety guidelines listed in the Safety instructions section.

1. Install the system cover.
2. If applicable, install the system into the rack.
For more information, see the *Rack Installation* placemat at Dell.com/poweredgemanuals.
3. If removed, install the front bezel.
4. Reconnect the peripherals and connect the system to the electrical outlet.
5. Turn on the system, including any attached peripherals.

Related tasks

[Installing the system cover](#)

[Installing the optional front bezel](#)

Recommended tools

You need the following tools to perform the removal and installation procedures:

- Key to the bezel lock. The key is needed only if your system includes a bezel.
- Phillips #1 screwdriver
- Phillips #2 screwdriver
- Wrist grounding strap

You need the following tools to assemble the cables for a DC power supply unit.

- AMP 90871-1 hand-crimping tool or equivalent
- Tyco Electronics 58433-3 or equivalent
- Wire-stripper pliers to remove insulation from size 10 AWG solid or stranded, insulated copper wire

 **NOTE:** Use alpha wire part number 3080 or equivalent (65/30 stranding).

Front bezel (optional)

The front bezel is attached to the front side of the system and prevents accidents while removing the hard drive or when pressing the reset or power button. The front bezel can also be locked for additional security.

Removing the optional front bezel

Follow the safety guidelines listed in the Safety instructions section.

1. Locate and remove the bezel key.

i **NOTE:** The bezel key is attached to the back of the bezel.

2. Unlock the bezel by using the key.
3. Slide the release latch up, and pull the left end of the bezel.
4. Unhook the right end, and remove the bezel.

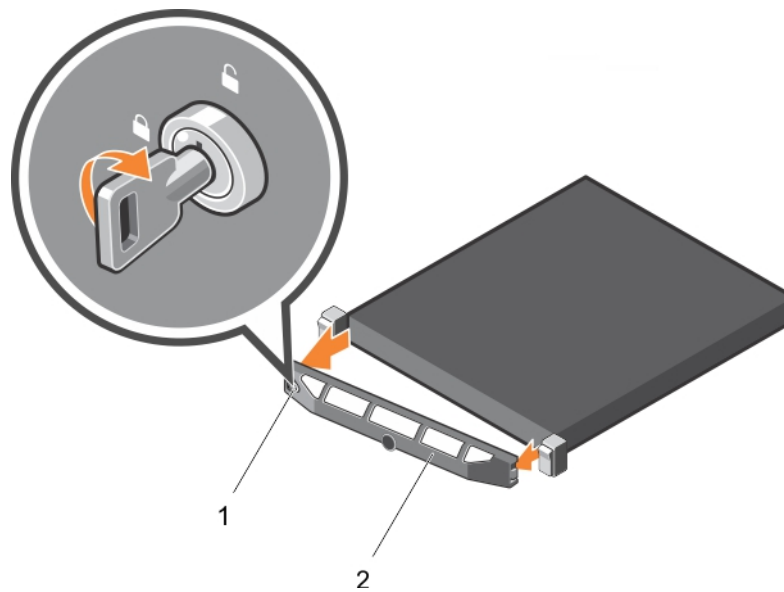

Figure 16. Removing the optional front bezel

- a. bezel lock
- b. front bezel

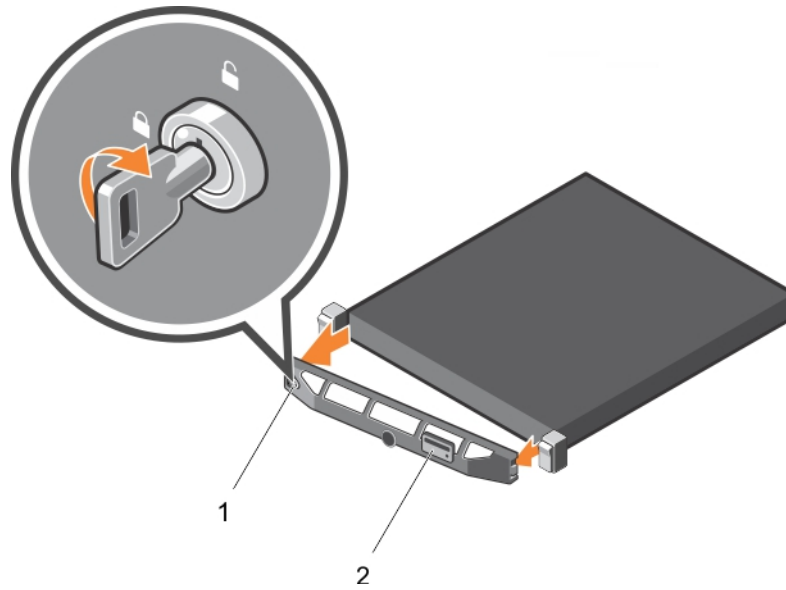

Figure 17. Removing the Quick Sync bezel

- a. bezel lock
- b. Quick Sync bezel

Related references

[Safety instructions](#)

Related tasks

[Installing the optional front bezel](#)

Installing the optional front bezel

Follow the safety guidelines listed in the Safety instructions section.

1. Locate and remove the bezel key.

i **NOTE:** The bezel key is attached to the back of the bezel.

2. Hook the right end of the bezel onto the chassis.
3. Fit the free end of the bezel onto the system.
4. Lock the bezel by using the key.

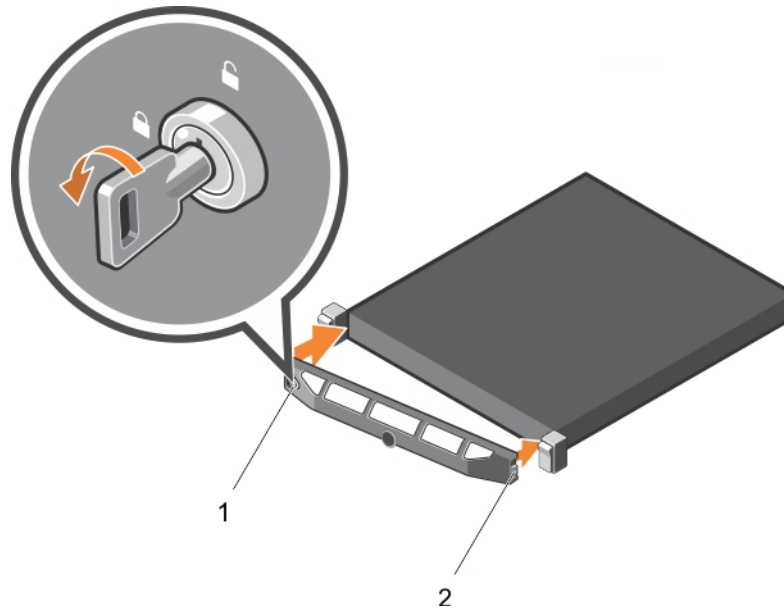

Figure 18. Installing the optional front bezel

- a. bezel lock
- b. front bezel

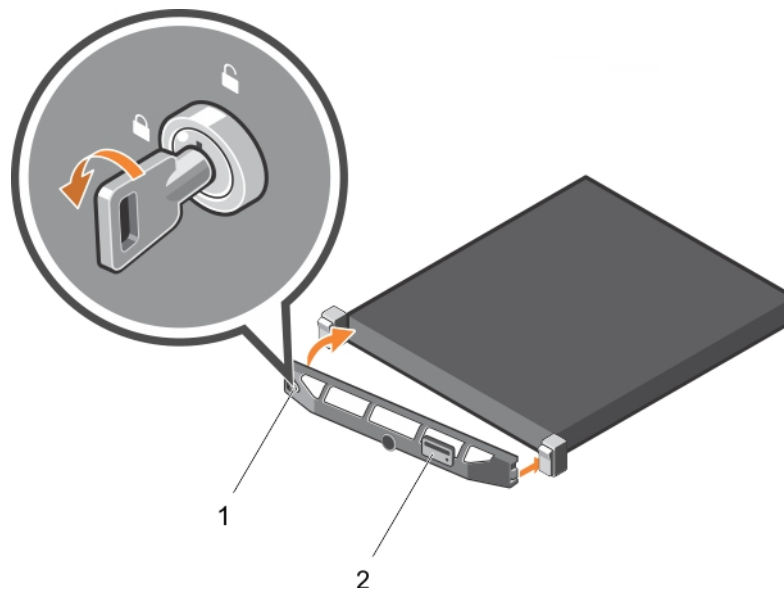

Figure 19. Installing the Quick Sync bezel

- a. bezel lock
- b. Quick Sync bezel

Related references

[Safety instructions](#)

Related tasks

[Removing the optional front bezel](#)

System cover

The system cover protects the components inside the system and helps in maintaining air flow inside the system. Removing the system cover activates the intrusion switch.

Removing the system cover

1. Follow the safety guidelines listed in the Safety instructions section.
2. Turn off the system, including any attached peripherals.
3. Disconnect the system from the electrical outlet and disconnect the peripherals.
4. If installed, remove the optional bezel.

1. Rotate the latch release lock counter clockwise to the unlocked position.
2. Lift the latch toward the back of the system.

The system cover slides back and the tabs on the system cover disengage from the slots on the chassis.

NOTE: The position of the latch may vary depending on the configuration of your system.

3. Hold the cover on both sides, and lift the cover away from the system.

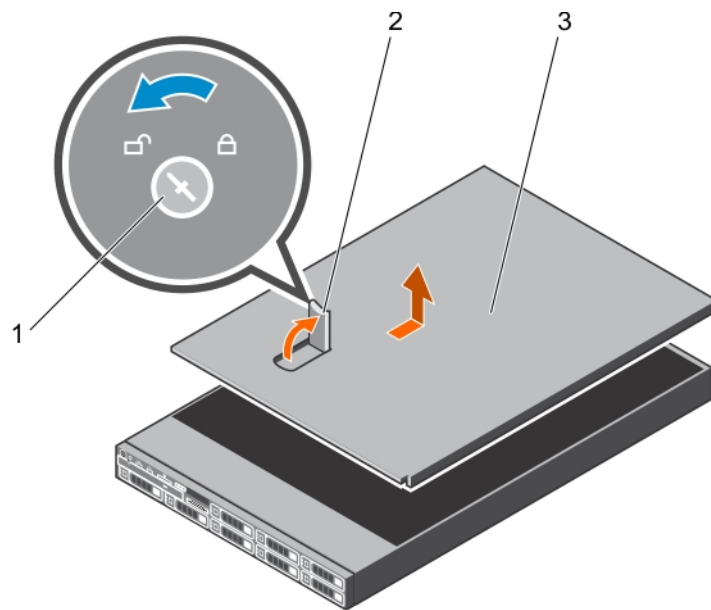

Figure 20. Removing the system cover

- a. latch release lock
- b. latch
- c. system cover

1. Install the system cover.

Related references

[Safety instructions](#)

Related tasks

[Removing the optional front bezel](#)

[Installing the system cover](#)

Installing the system cover

1. Follow the safety guidelines listed in the Safety instructions section.

2. Follow the procedure listed in the Before working inside your system section.
 3. Ensure that all internal cables are connected and placed out of the way, and no tools or extra parts are left inside the system.
1. Align the slots on the system cover with the tabs on the chassis.
 2. Push the system cover latch down.

The system cover slides forward and the slots on the system cover engage with the tabs on the chassis. The system cover latch locks into place when the system cover is completely engaged with the tabs on the chassis.
 3. Rotate the latch release lock clockwise to the locked position.

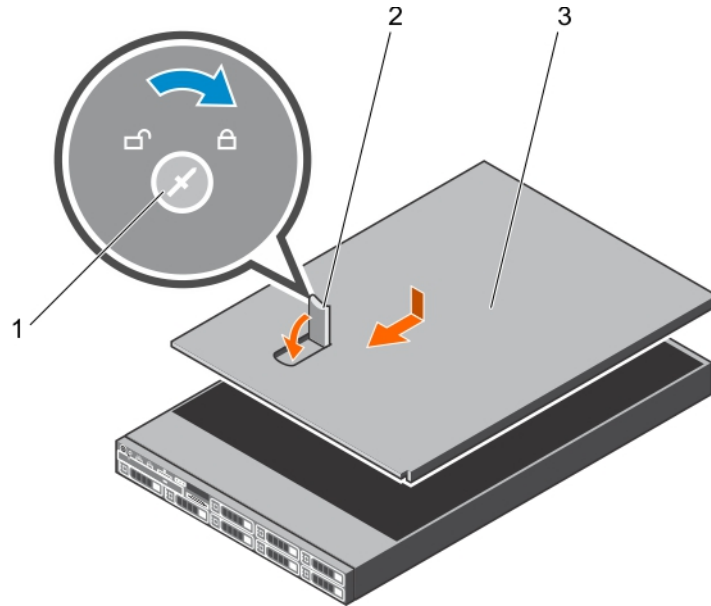

Figure 21. Installing the system cover

- a. latch release lock
 - b. latch
 - c. system cover
1. If removed, install the front bezel.
 2. Reconnect the peripherals and connect the system to the electrical outlet.
 3. Turn on the system, including any attached peripherals.
 4. Follow the procedure listed in the After working inside your system section.

Related references

[Safety instructions](#)

Related tasks

[Installing the optional front bezel](#)

[Removing the system cover](#)

Inside the system

NOTE: Components that are hot swappable are marked orange and touch points on the components are marked blue.

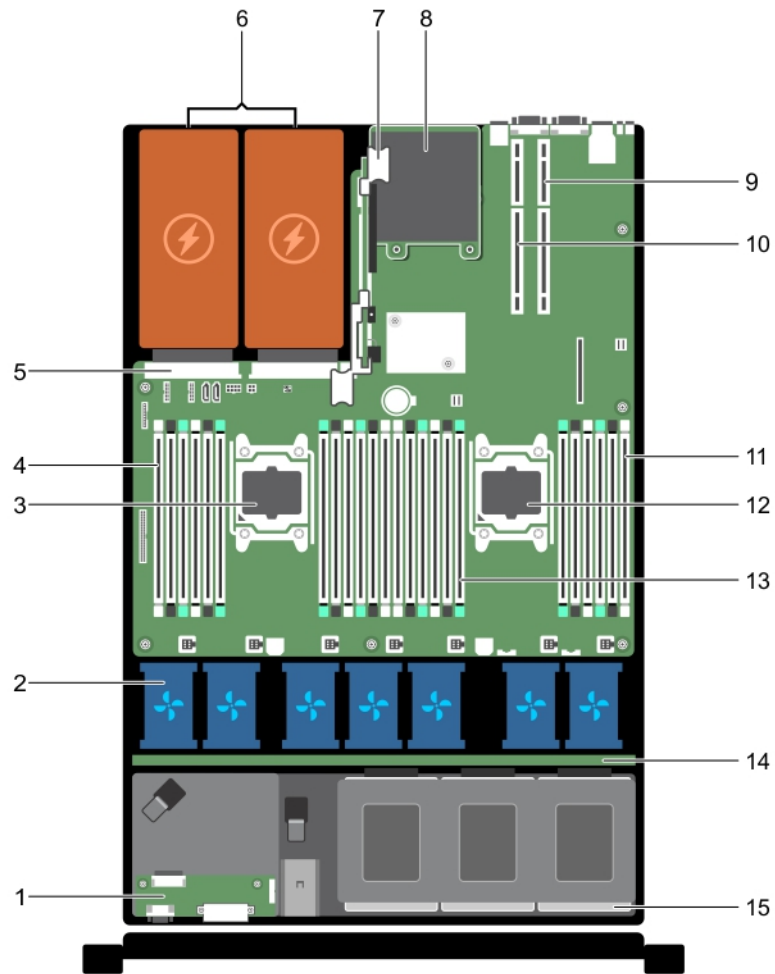

Figure 22. Inside the system—eight hard drive system

- | | |
|--------------------------------------|--------------------------|
| 1. control panel assembly | 2. cooling fans (7) |
| 3. processor 1 | 4. DIMMs (6) |
| 5. power supply unit (PSU) connector | 6. PSU (2) |
| 7. riser card 3 | 8. network daughter card |
| 9. riser card 2 | 10. riser card 1 |
| 11. DIMMs (6) | 12. processor 2 |
| 13. DIMMs (12) | 14. hard drive backplane |
| 15. hard drive | |

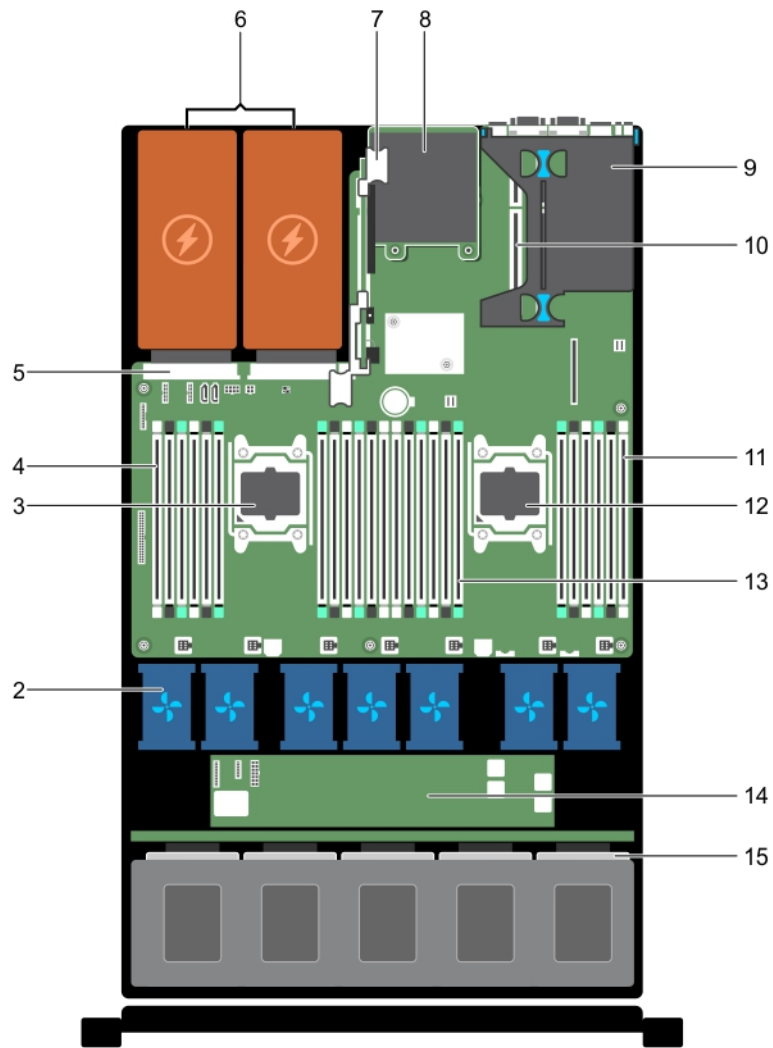

Figure 23. Inside the system—24 hard drive system and 10 hard drive system

- | | |
|---------------------------|--------------------------|
| 1. control panel assembly | 2. cooling fans (7) |
| 3. processor 1 | 4. DIMMs (6) |
| 5. PSU connector | 6. PSU 2 |
| 7. riser card 3 | 8. network daughter card |
| 9. riser card 1 | 10. riser card 2 |
| 11. DIMMs (6) | 12. processor 2 |
| 13. DIMMs (12) | 14. expander board |
| 15. hard drive | |

Cooling shroud

The cooling shroud aerodynamically directs the airflow across the entire system. The airflow passes through all the critical parts of the system, where the vacuum pulls air across the entire surface area of the heat sink, thus allowing increased cooling.

Removing the cooling shroud

CAUTION: Many repairs may only be done by a certified service technician. You should only perform troubleshooting and simple repairs as authorized in your product documentation, or as directed by the online or telephone service and support team. Damage due to servicing that is not authorized by Dell is not covered by your warranty. Read and follow the safety instructions that are shipped with your product.

CAUTION: Never operate your system with the air shroud removed. The system may get overheated quickly, resulting in shutdown of the system and loss of data.

1. Follow the safety guidelines listed in the Safety instructions section.
2. Follow the procedure listed in the Before working inside your system section.

Holding the touch points, lift the cooling shroud away from the system.

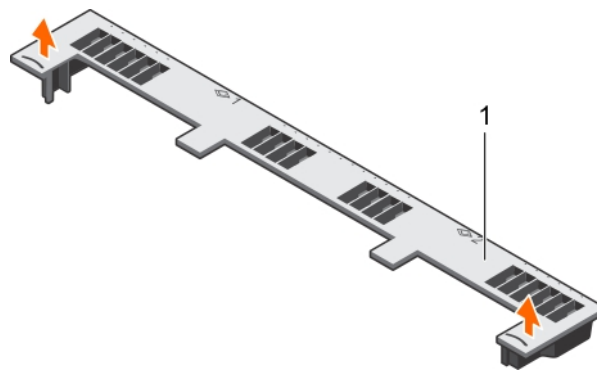

Figure 24. Removing the cooling shroud

a. cooling shroud

1. Install the cooling shroud.
2. Follow the procedure listed in the After working inside your system section.

Related references

[Safety instructions](#)

Related tasks

[Before working inside your system](#)

[Installing the cooling shroud](#)

[After working inside your system](#)

Installing the cooling shroud

CAUTION: Many repairs may only be done by a certified service technician. You should only perform troubleshooting and simple repairs as authorized in your product documentation, or as directed by the online or telephone service and support team. Damage due to servicing that is not authorized by Dell is not covered by your warranty. Read and follow the safety instructions that are shipped with your product.

1. Follow the safety guidelines listed in the Safety instructions section.
2. Follow the procedure listed in the Before working inside your system section.

3. If applicable, route the cables inside the system along the chassis wall and secure the cables by using the cable-securing bracket.
1. Align the tabs on the cooling shroud with the securing slots on the chassis.
2. Lower the cooling shroud into the chassis until it is firmly seated.

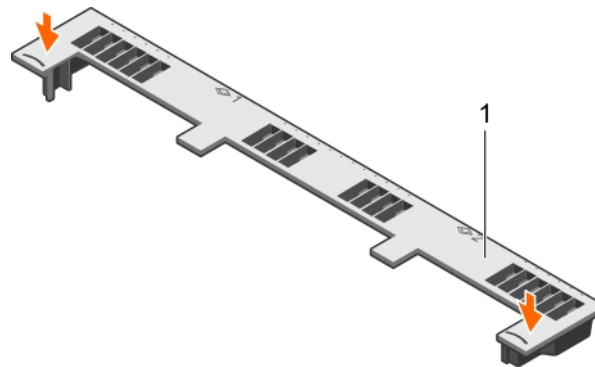

Figure 25. Installing the cooling shroud

a. cooling shroud

1. Follow the procedure listed in the After working inside your system section.

Related references

[Safety instructions](#)

Related tasks

[Before working inside your system](#)

[After working inside your system](#)

[Removing the cooling shroud](#)

System memory

Removing memory modules

CAUTION: Many repairs may only be done by a certified service technician. You should only perform troubleshooting and simple repairs as authorized in your product documentation, or as directed by the online or telephone service and support team. Damage due to servicing that is not authorized by Dell is not covered by your warranty. Read and follow the safety instructions that are shipped with your product.

1. Follow the safety guidelines listed in the Safety instructions section.
2. Follow the procedure listed in the Before working inside your system section.
3. Remove the cooling shroud.

NOTE: The memory modules are hot to touch for some time after the system has been powered down. Allow the memory modules to cool before handling them. Handle the memory modules by the card edges and avoid touching the components or metallic contacts on the memory module.

CAUTION: To ensure proper system cooling, memory module blanks must be installed in any memory socket that is not occupied. Remove memory module blanks only if you intend to install memory modules in those sockets.

1. Locate the appropriate memory module socket.

CAUTION: Handle each memory module only by the card edges, ensuring not to touch the middle of the memory module or metallic contacts.

2. To release the memory module from the socket, simultaneously press the ejectors on both ends of the memory module socket.
3. Lift and remove the memory module from the system.

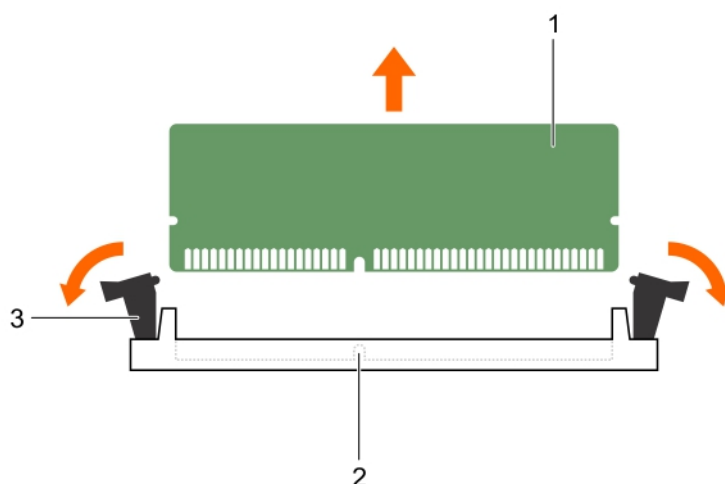

Figure 26. Removing the memory module

- a. memory module
- b. memory module socket
- c. memory module socket ejector (2)

1. Install the memory module.

NOTE: If you are removing the memory module permanently, install a memory module blank.

2. Install the cooling shroud.
3. Follow the procedure listed in the After working inside your system section.

Related references

[Safety instructions](#)

Related tasks

[Before working inside your system](#)

[Removing the cooling shroud](#)

[Installing memory modules](#)

Installing memory modules

NOTE: The memory modules are hot to touch for some time after the system has been powered down. Allow the memory modules to cool before handling them. Handle the memory modules by the card edges and avoid touching the components or metallic contacts on the memory module.

CAUTION: Many repairs may only be done by a certified service technician. You should only perform troubleshooting and simple repairs as authorized in your product documentation, or as directed by the online or telephone service and support team. Damage due to servicing that is not authorized by Dell is not covered by your warranty. Read and follow the safety instructions that are shipped with your product.

CAUTION: To ensure proper system cooling, memory module blanks must be installed in any memory socket that is not occupied. Remove memory module blanks only if you intend to install memory modules in those sockets.

1. Follow the safety guidelines listed in the Safety instructions section.
2. Follow the procedure listed in the Before working inside your system section.
3. Removing the cooling fan assembly.
4. Remove the cooling shroud.

1. Locate the appropriate memory module socket.

CAUTION: Handle each memory module only by the card edges, ensuring not to touch the middle of the memory module or metallic contacts.

2. Open the ejectors on the memory module socket outward to allow the memory module to be inserted into the socket.
3. Align the edge connector of the memory module with the alignment key of the memory module socket, and insert the memory module in the socket.

CAUTION: Do not apply pressure at the center of the memory module; apply pressure at both ends of the memory module evenly.

NOTE: The memory module socket has an alignment key that enables you to install the memory module in the socket in only one orientation.

4. Press the memory module with your thumbs until the socket levers firmly click into place.

When the memory module is properly seated in the socket, the levers on the memory module socket align with the levers on the other sockets that have memory modules installed.

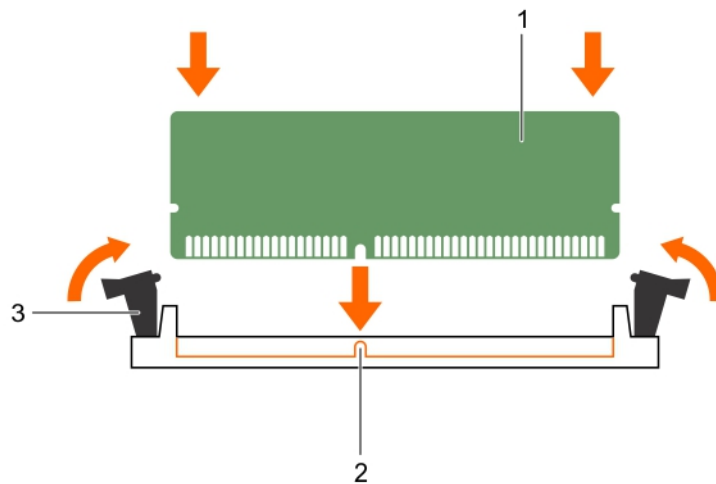

Figure 27. Installing the memory module

- a. memory module
- b. alignment key
- c. memory module socket ejector (2)

1. Install the cooling shroud.
2. Follow the procedure listed in the After working inside your system section.
3. Press F2 to enter System Setup, and check the **System Memory** setting. The system should have already changed the value to reflect the installed memory.
4. If the value is incorrect, one or more of the memory modules may not be installed properly. Ensure that the memory module is firmly seated in the memory module socket.
5. Run the system memory test in system diagnostics.

Related references

[Safety instructions](#)

Related tasks

[Before working inside your system](#)

[Removing the cooling shroud](#)

[After working inside your system](#)

[Installing the cooling shroud](#)

Hard drives

All hard drives connect to the system board through the hard drive backplane. Hard drives are supplied in hot swappable hard drive carriers that fit in the hard drive slots.

CAUTION: Before attempting to remove or install a hard drive while the system is running, see the documentation for the storage controller card to ensure that the host adapter is configured correctly to support hot swappable hard drive removal and insertion.

CAUTION: Do not turn off or reboot your system while the hard drive is being formatted. Doing so can cause a hard drive failure.

NOTE: Use only hard drives that have been tested and approved for use with the hard drive backplane.

When you format a hard drive, allow enough time for the formatting to be completed. High-capacity hard drives can take several hours to format.

Removing a 2.5-inch hard drive blank

CAUTION: Many repairs may only be done by a certified service technician. Perform troubleshooting and simple repairs as authorized in your product documentation, or as directed by the online or telephone service and support team. Damage due to servicing that is not authorized by Dell is not covered by your warranty. Read and follow the safety instructions that came with the product.

CAUTION: To maintain proper system cooling, all empty hard drive slots must have hard drive blanks installed.

1. Follow the safety guidelines listed in the Safety instructions section.
2. If installed, remove the bezel.

Press the release button and slide the hard drive blank out of the hard drive slot.

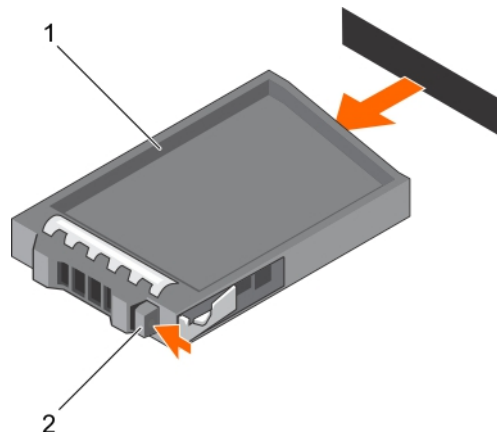

Figure 28. Removing a 2.5-inch hard drive blank

- a. hard drive blank
- b. release button

Related references

[Safety instructions](#)

Related tasks

[Removing the optional front bezel](#)

Installing a 2.5-inch hard drive blank

1. Follow the safety guidelines listed in the Safety instructions section.
2. If installed, remove the front bezel.

Insert the hard drive blank into the hard drive slot until the release button clicks into place.

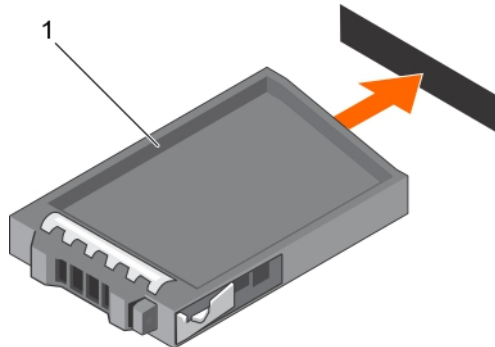

Figure 29. Installing a 2.5-inch hard drive blank

- a. hard drive blank

If removed, install the front bezel.

Related references

[Safety instructions](#)

Related tasks

[Removing the optional front bezel](#)

[Installing the optional front bezel](#)

Removing a 1.8-inch hard drive blank

1. Follow the safety guidelines listed in the Safety instructions section.
2. If installed, remove the front bezel.

CAUTION: To maintain proper system cooling, all empty hard drive slots must have hard drive blanks installed.

Press the release button and slide the hard drive blank out of the hard drive slot.

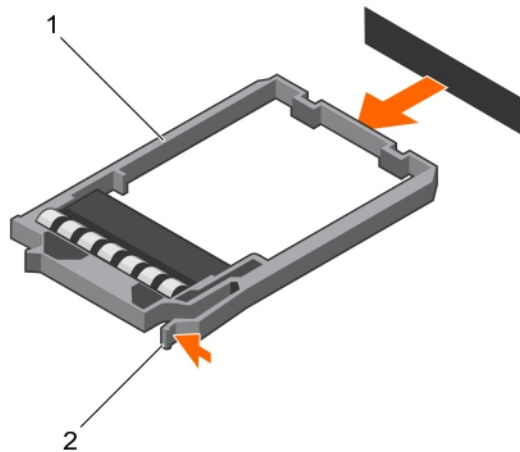

Figure 30. Removing a 1.8-inch hard drive blank

- a. hard drive blank
- b. release button

If applicable, install the front bezel.

Related references

[Safety instructions](#)

Related tasks

[Removing the optional front bezel](#)

Installing a 1.8-inch hard drive blank

1. Follow the safety guidelines listed in the Safety instructions section.
2. If installed, remove the front bezel.

Insert the hard drive blank into the hard drive slot until the release button clicks into place.

If applicable, install the front bezel.

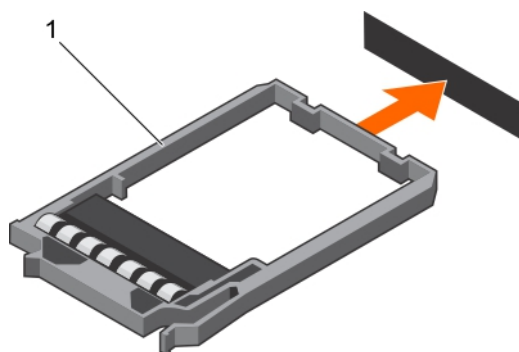

Figure 31. Installing a 1.8-inch hard drive blank

1. hard drive blank

Related references

[Safety instructions](#)

Related tasks

[Removing the optional front bezel](#)

[Installing the optional front bezel](#)

Removing a hot swappable hard drive or solid state drive

CAUTION: Many repairs may only be done by a certified service technician. You should only perform troubleshooting and simple repairs as authorized in your product documentation, or as directed by the online or telephone service and support team. Damage due to servicing that is not authorized by Dell is not covered by your warranty. Read and follow the safety instructions that came with the product.

1. Follow the safety guidelines listed in the Safety instructions section.
2. Follow the procedure listed in the Before working inside your system section.
3. If applicable, remove the bezel.
4. Using the management software, prepare the hard drive for removal. If the hard drive is online, the green activity or fault indicator flashes while the drive is turning off. When the hard drive indicators are off, the hard drive is ready for removal.

For more information, see the documentation for the storage controller.

CAUTION: To prevent data loss, ensure that your operating system supports hot-swap drive installation. See the documentation supplied with your operating system.

1. Press the release button to open the hard drive or SSD carrier release handle.
2. Slide the hard drive or SSD carrier out of the hard drive slot.

CAUTION: To maintain proper system cooling, all empty hard drive or SSD slots must have hard drive or SSD blanks installed.

3. If you are not replacing the hard drive or SSD immediately, insert a hard drive or SSD blank in the empty hard drive slot.

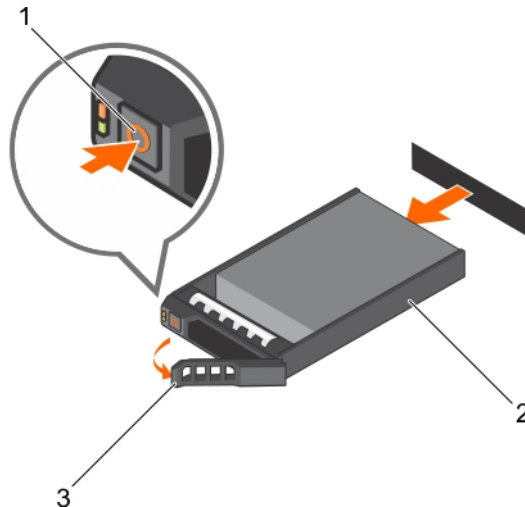

Figure 32. Removing a hot swappable hard drive or SSD

- a. release button
- b. hard drive or SSD carrier
- c. hard drive or SSD carrier handle

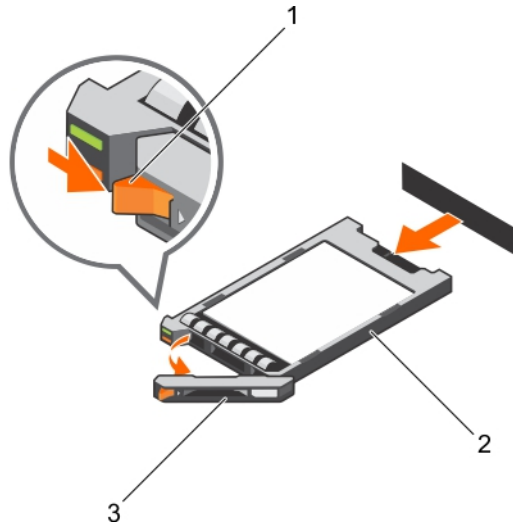

Figure 33. Removing a 1.8 inch hot-swappable uSATA SSD carrier

- a. release button
- b. SSD carrier
- c. SSD carrier handle

Related references

[Safety instructions](#)

Related tasks

[Removing the optional front bezel](#)

Installing a hot swappable hard drive

- △ **CAUTION:** Many repairs may only be done by a certified service technician. You should only perform troubleshooting and simple repairs as authorized in your product documentation, or as directed by the online or telephone service and support team. Damage due to servicing that is not authorized by Dell is not covered by your warranty. Read and follow the safety instructions that are shipped with your product.
- △ **CAUTION:** Use only hard drives that have been tested and approved for use with the hard drive backplane.
- △ **CAUTION:** Combining SAS and SATA hard drives in the same RAID volume is not supported.
- △ **CAUTION:** When installing a hard drive, ensure that the adjacent drives are fully installed. Inserting a hard drive carrier and attempting to lock its handle next to a partially installed carrier can damage the partially installed carrier's shield spring and make it unusable.
- △ **CAUTION:** To prevent data loss, ensure that your operating system supports hot-swap drive installation. See the documentation supplied with your operating system.
- △ **CAUTION:** When a replacement hot swappable drive is installed and the system is powered on, the drive automatically begins to rebuild. Ensure that the replacement drive is blank or contains data that you wish to overwrite. Any data on the replacement drive is immediately lost after the drive is installed.

1. Follow the safety guidelines listed in Safety instructions section.
1. If a hard drive blank is installed in the hard drive slot, remove it.
2. Install a hard drive in the hard drive carrier. For more information, see the Installing a hot swappable hard drive into a hot swappable hard drive carrier section.
3. Press the release button on the front of the hard drive carrier and open the hard drive carrier handle.
4. Insert the hard drive carrier into the hard drive slot until the carrier connects with the backplane.

5. Close the hard drive carrier handle to lock the hard drive in place.
Install the optional front bezel.

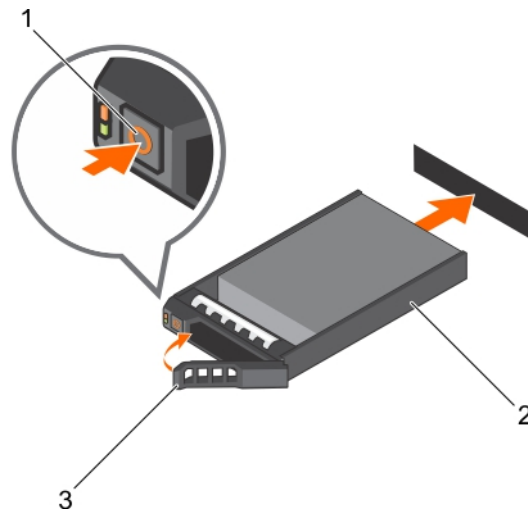

Figure 34. Installing a hot swappable hard drive

1. release button
2. hard drive or SSD carrier
3. hard drive or SSD carrier handle

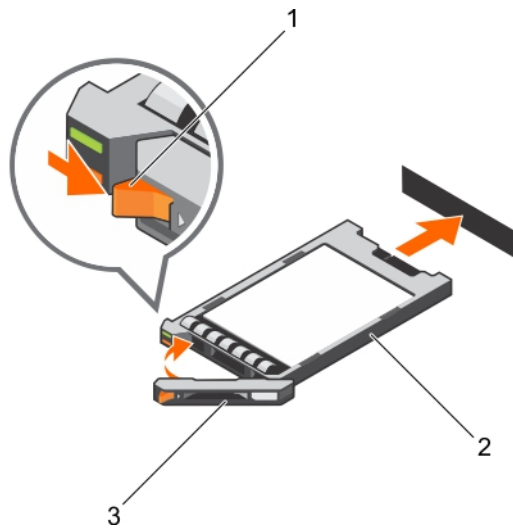

Figure 35. Installing a 1.8-inch hot swappable uSATA SSD

1. release button
2. SSD carrier
3. SSD carrier handle

Related references

[Safety instructions](#)

Related tasks

[Installing a hot swappable hard drive into a hot swappable hard drive carrier](#)

[Installing the optional front bezel](#)

Removing a hard drive or a solid state drive from a hard drive carrier

1. Keep the Phillips #1 screwdriver ready.
2. Remove the hot swappable hard drive carrier from the system.
1. Remove the screws from the slide rails on the hard drive carrier.
2. Lift the hard drive out of the hard drive carrier.

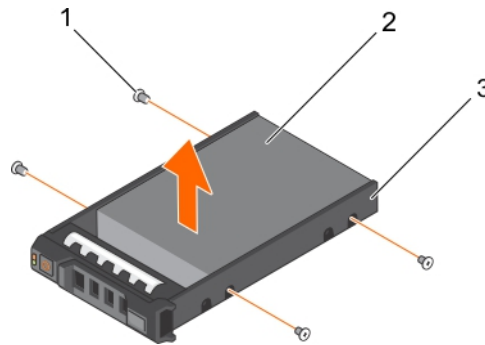

Figure 36. Removing a hard drive from a hard drive carrier

- a. screw (4)
- b. hard drive
- c. hard drive carrier

If applicable, install a hard drive into the hard drive carrier.

Installing a hot swappable hard drive into a hot swappable hard drive carrier

CAUTION: Many repairs may only be done by a certified service technician. You should only perform troubleshooting and simple repairs as authorized in your product documentation, or as directed by the online or telephone service and support team. Damage due to servicing that is not authorized by Dell is not covered by your warranty. Read and follow the safety instructions that are shipped with your product.

NOTE: Hot swappable hard drives are supplied in hot swappable hard drive carriers that fit in the hard drive slots.

1. Keep the Phillips #2 screwdriver ready.
2. Remove the hot swappable hard drive carrier.
 1. Insert the hot swappable hard drive into the hard drive carrier with the connector end of the hard drive toward the back.
 2. Align the screw holes on the hard drive with the set of screw holes on the hard drive carrier.
When aligned correctly, the back of the hard drive is flush with the back of the hard drive carrier.
 3. Attach the screws to secure the hard drive to the hard drive carrier.

Install the hard drive carrier into the system.

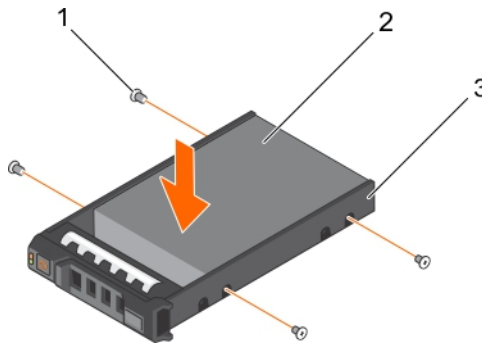

Figure 37. Installing a hot swappable hard drive into a hot swappable hard drive carrier

1. screw (4)
2. hard drive
3. hard drive carrier

Removing a 1.8-inch hard drive from a hard drive carrier

1. Follow the safety guidelines listed in the Safety instructions section.
2. Remove the hard drive carrier from the system.
 1. Turn the hard drive carrier.
 2. Pull the rails of the hard drive carrier and lift the hard drive out of the hard drive carrier.

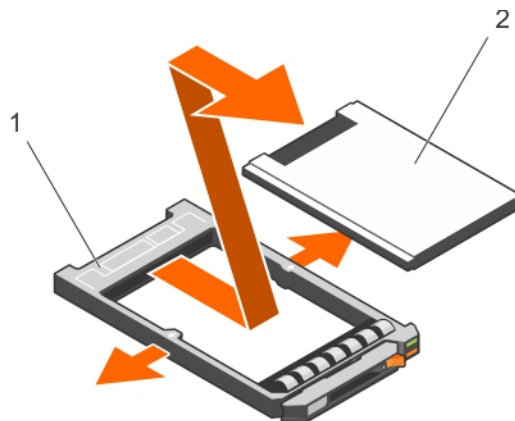

Figure 38. Removing a 1.8-inch hard drive into a hard drive carrier

- a. hard drive carrier
- b. hard drive

Related references

[Safety instructions](#)

Installing a 1.8-inch hard drive into a hard drive carrier

CAUTION: Many repairs may only be done by a certified service technician. You should only perform troubleshooting and simple repairs as authorized in your product documentation, or as directed by the online or telephone service and support team. Damage due to servicing that is not authorized by Dell is not covered by your warranty. Read and follow the safety instructions that are shipped with your product.

Insert the hard drive into the hard drive carrier with the connector end of the hard drive toward the back. When aligned correctly, the back of the hard drive is flush with the back of the hard drive carrier.

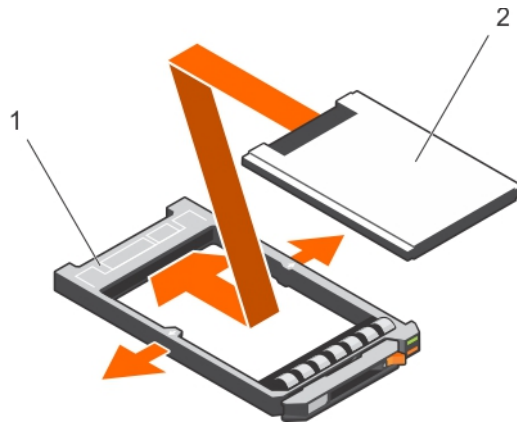

Figure 39. Installing a 1.8-inch hard drive into a hard drive carrier

- a. hard drive carrier
- b. hard drive

Optical drive (optional)

Optical drives retrieve and store data on optical discs such as CD and DVD. Optical drives can be categorized into two basic types: optical disc readers and optical disc writers.

Removing the optional optical drive

CAUTION: Many repairs may only be done by a certified service technician. You should only perform troubleshooting and simple repairs as authorized in your product documentation, or as directed by the online or telephone service and support team. Damage due to servicing that is not authorized by Dell is not covered by your warranty. Read and follow the safety instructions that are shipped with your product.

NOTE: This procedure applies only to the eight hard drive system.

1. Follow the safety guidelines listed in the Safety instructions section.
2. Follow the procedure listed in the Before working inside your system section.
1. Disconnect the power and data cables from the back of the drive.

NOTE: Ensure that you note the routing of the power and data cable on the side of the system as you remove them from the system board and drive. Route these cables properly when you replace them to prevent them from being pinched or crimped.

2. To release the optical drive, press the release tab.
3. Slide the optical drive out of the system until it is free of the optical drive slot.
4. If you are not adding a new optical drive, install the optical drive blank. The procedure to install the optical drive blank is the same as the optical drive.

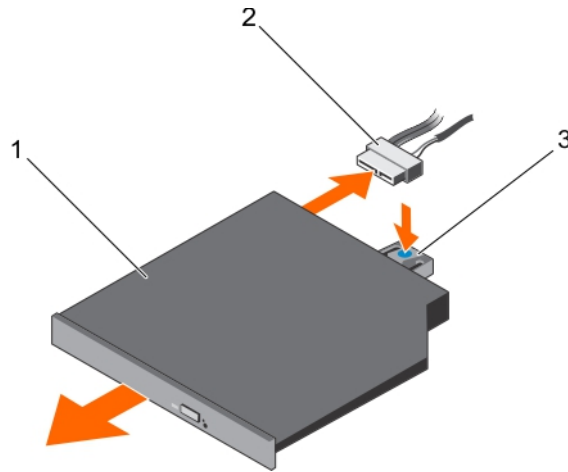

Figure 40. Removing the optional optical drive

- a. optical drive
- b. power and data cable
- c. release tab

Follow the procedure listed in the After working inside your system section.

Related references

[Safety instructions](#)

Related tasks

[Before working inside your system](#)

[After working inside your system](#)

[Installing the optional optical drive](#)

Installing the optional optical drive

CAUTION: Many repairs may only be done by a certified service technician. You should only perform troubleshooting and simple repairs as authorized in your product documentation, or as directed by the online or telephone service and support team. Damage due to servicing that is not authorized by Dell is not covered by your warranty. Read and follow the safety instructions that are shipped with your product.

NOTE: This procedure applies only to the eight hard drive system.

1. Follow the safety guidelines listed in the Safety instructions section.
2. Follow the procedure listed in the Before working inside your system section.
3. If installed, remove the optical drive blank.
1. Align the optical drive with the optical drive slot on the front of the chassis.
2. Slide in the optical drive until the release tab snaps into place.
3. Connect the power and data cable to the optical drive and system board.

NOTE: Route the cable properly on the side of the system to prevent it from being pinched or crimped.

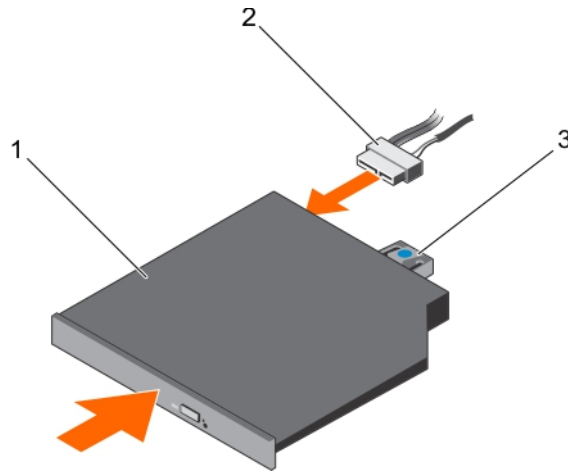

Figure 41. Installing the optional optical drive

- a. optical drive
- b. power and data cable
- c. release tab

Follow the procedure listed in the After working inside your system section.

Related references

[Safety instructions](#)

Related tasks

[Before working inside your system](#)

[After working inside your system](#)

[Removing the optional optical drive](#)

Removing the slim optical drive blank

CAUTION: Many repairs may only be done by a certified service technician. You should only perform troubleshooting and simple repairs as authorized in your product documentation, or as directed by the online or telephone service and support team. Damage due to servicing that is not authorized by Dell is not covered by your warranty. Read and follow the safety instructions that are shipped with your product.

1. Follow the safety guidelines listed in the Safety instructions section.
2. Follow the procedure listed in the Before working inside your system section.
 1. Locate the touch point for the slim optical drive blank lock inside the system.
 2. Press the lock and pull the slim optical drive blank out of the chassis.

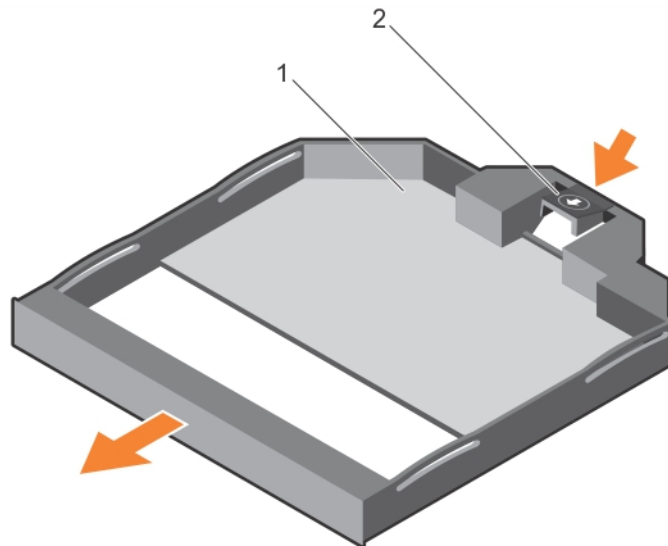

Figure 42. Removing the slim optical drive blank

- a. slim optical drive blank
- b. optical drive blank lock

Related references

[Safety instructions](#)

Related tasks

[Before working inside your system](#)

[Installing the slim optical drive blank](#)

Installing the slim optical drive blank

CAUTION: Many repairs may only be done by a certified service technician. You should only perform troubleshooting and simple repairs as authorized in your product documentation, or as directed by the online or telephone service and support team. Damage due to servicing that is not authorized by Dell is not covered by your warranty. Read and follow the safety instructions that are shipped with your product.

1. Follow the safety instructions listed in the Safety instructions section.
2. Follow the procedure listed in the Before working inside your system section.
 1. Align the slim optical drive blank with the slim optical drive bay.
 2. Slide the optical drive blank into the optical drive bay until the lock clicks into place.

Follow the procedure listed in the After working inside your system section.

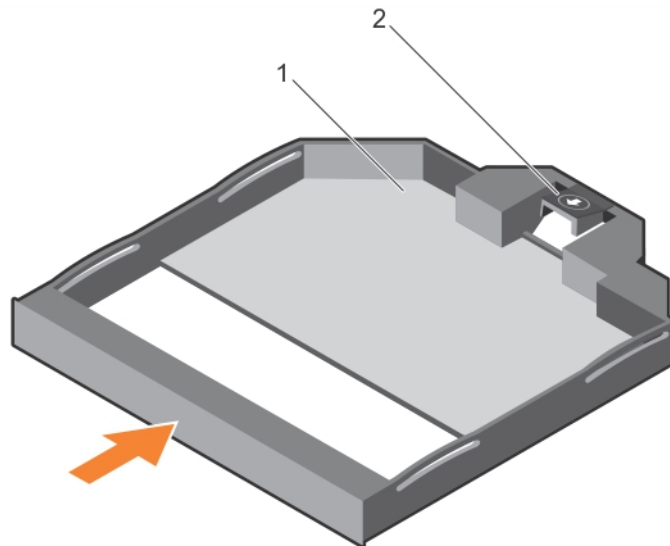

Figure 43. Installing the slim optical drive blank

1. slim optical drive blank
2. optical drive blank lock

Related references

[Safety instructions](#)

Related tasks

[After working inside your system](#)

[Removing the slim optical drive blank](#)

Cooling fans

Your system supports seven hot swappable cooling fans.

i **NOTE:** In the event of a problem with a particular fan, the fan number is referenced by the system management software, allowing you to easily identify and replace the proper fan by noting the fan numbers on the cooling fan assembly.

Removing a cooling fan

i **NOTE:** Opening or removing the system cover when the system is ON may expose you to a risk of electric shock. Exercise utmost care while removing or installing cooling fans.

△ **CAUTION:** Many repairs may only be done by a certified service technician. You should only perform troubleshooting and simple repairs as authorized in your product documentation, or as directed by the online or telephone service and support team. Damage due to servicing that is not authorized by Dell is not covered by your warranty. Read and follow the safety instructions that are shipped with your product.

△ **CAUTION:** The cooling fans are hot swappable. To maintain proper cooling while the system is on, replace only one fan at a time.

△ **CAUTION:** Do not operate the system with the cover removed for a duration exceeding five minutes.

i **NOTE:** The procedure for removing each fan is identical.

1. Follow the safety guidelines listed in the Safety instructions section.
2. Follow the procedure listed in the Before working inside your appliance section.

Hold the fan and lift it out of the system.

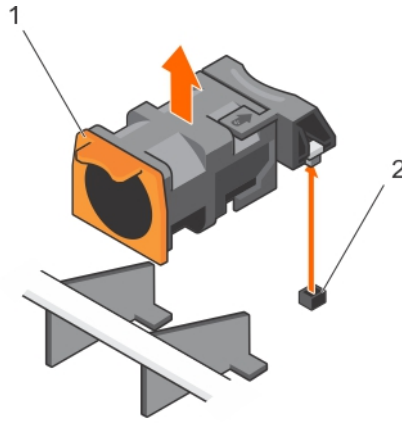

Figure 44. Removing a cooling fan

1. cooling fan (7)
2. connector on the system board (7)

Related references

[Safety instructions](#)

Related tasks

[Before working inside your system](#)

[Installing a cooling fan](#)

Installing a cooling fan

1. Follow the safety guidelines listed in the Safety instructions section.
2. Follow the procedure listed in the Before working inside your system section.

(i) NOTE: The procedure for installing each fan is identical.

1. Align the connector at the base of the cooling fan with the connector on the system board.
2. Slide the cooling fan into the securing slot until the tab locks into place.

Follow the procedure listed in the After working inside your system section.

Related references

[Safety instructions](#)

Related tasks

[Before working inside your system](#)

[After working inside your system](#)

[Removing a cooling fan](#)

Internal USB memory key (optional)

An optional USB memory key installed inside your system can be used as a boot device, security key, or mass storage device.

To boot from the USB memory key, configure the USB memory key with a boot image and then specify the USB memory key in the boot sequence in System Setup.

The internal USB port must be enabled in **Internal USB Port** option in the **Integrated Devices** screen of **System Setup**.

(i) NOTE: To locate the internal USB port J_USB_INT on the system board, see the System board jumpers and connectors section.

Related references

[System board jumpers and connectors](#)

Replacing the optional internal USB memory key

1. Follow the safety guidelines listed in the Safety instructions section.
2. Follow the procedure listed in the Before working inside your system section.
1. Locate the USB port or USB memory key on the system board.
To locate the USB port, see the System board jumpers and connectors section.
2. If installed, remove the USB memory key from the USB port.

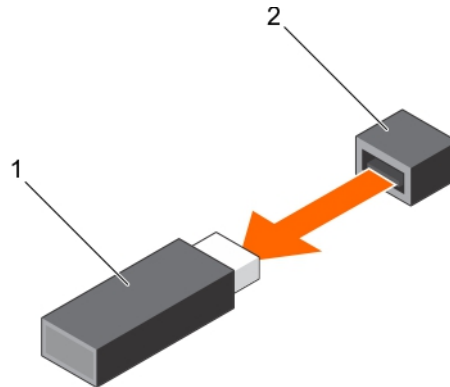

Figure 45. Removing the internal USB memory key

- a. USB memory key
- b. USB port

3. Insert the replacement USB memory key into the USB port.

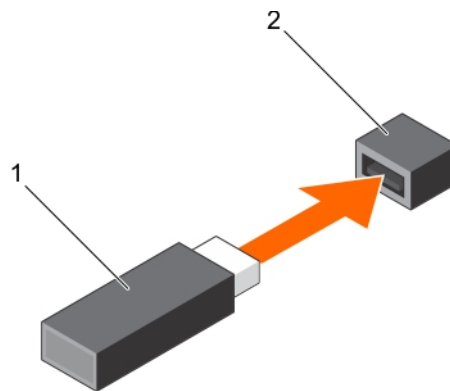

Figure 46. Installing the internal USB memory key

- a. USB memory key
- b. USB port

1. Follow the procedure listed in the After working inside your system section.
2. While booting, press F2 to enter System Setup and verify that the system detects the USB memory key.

Related concepts

[System Setup](#)

Related references

[Safety instructions](#)

[System board jumpers and connectors](#)

Related tasks

Before working inside your system

After working inside your system

Expansion cards and expansion card riser

An expansion card in the system is an add-on card that can be inserted into an expansion slot on the system board or riser card to add enhanced functionality to the system through the expansion bus.

NOTE: A System Event Log (SEL) event is logged if an expansion card riser is unsupported or missing. It does not prevent your system from turning on and no BIOS POST message or F1/F2 pause is displayed.

Expansion card installation guidelines

Your system supports PCI Express Generation 3 expansion cards.

Table 36. Guidelines for systems supporting three PCIe expansion cards

Riser	PCIe Slot	Processor Connection	Height	Length	Link Width	Slot Width
1	1	Processor 2	Low Profile	Half Length	x16	x16
1	2	Processor 2	Low Profile	Half Length	x8	x16
3	3	Processor 1	Low Profile	Half Length	x16	x16

NOTE: Both the processors must be installed to use riser 1 slots.

Table 37. Guidelines for systems supporting two PCIe expansion cards

Riser	PCIe Slot	Processor Connection	Height	Length	Link Width	Slot Width
2	1	Processor 1	Low Profile	Half Length	x8	x16
		Processor 2	Low Profile	Half Length	x16	x16
3	2	Processor 1	Full height	Three-fourth Length	x16	x16

NOTE: Only a three-fourth length card is supported for the PCIe expansion card slot (slot 2) on riser 3 when no mini-PERC card is installed. Supported length with mini-PERC card installed is half length.

NOTE: For a system with three PCIe cards, only MiniSAS HD third-party cards are supported in slot 3. For a system with two PCIe cards, only MiniSAS HD third-party cards are supported in slot 1.

NOTE: You can install expansion cards only on one slot on riser 2.

NOTE: Both the processors must be installed to use the x16 PCIe link on the riser 2 slot.

The following table provides a guide for installing expansion cards to ensure proper cooling and mechanical fit. Install the expansion card by following the card priority and slot priority order as shown in the table.

Table 38. Expansion card installation priority

Card Priority	Card Type	Systems Supporting up to 2 PCIe Expansion Cards		Systems Supporting up to 3 PCIe Expansion Cards	
		Slot Priority	Max Allowed	Slot Priority	Max Allowed
1	PCIe Bridge	N/A	N/A	1	1
2	RAID	1	1	3, 1	2
3	100 G HCA/OPA HFI	1	1	3, 2 (3, 1 for CX4/OPA)	2

Table 38. Expansion card installation priority (continued)

Card Priority	Card Type	Systems Supporting up to 2 PCIe Expansion Cards		Systems Supporting up to 3 PCIe Expansion Cards	
		Slot Priority	Max Allowed	Slot Priority	Max Allowed
4	40 G NICs	2, 1	2	3, 2	2
5	FC16 HBA	2, 1	2	3, 2, 1	3
6	10 Gb NICs	2, 1	2	3, 2, 1	3
7	FC8 HBA	2, 1	2	3, 2, 1	3
8	1 Gb NICs	2, 1	2	3, 2, 1	3
9	Non-RAID 12 Gb SAS	1	1	3, 1	2
10	Integrated RAID	Integrated Slot	1	Integrated Slot	1
11	NDC	Integrated Slot	1	Integrated Slot	1
12	NVMe PCIe SSD	1,2	2	3, 2, 1	2

NOTE: To support x16 PCIe link width, the 100 G HCA/OPA HFI in slot 1 needs processor 2 and x16 center_riser2.

Removing expansion card risers

1. Follow the safety guidelines listed in the Safety instructions section.
2. Follow the procedure listed in the Before working inside your system section.

CAUTION: Many repairs may only be done by a certified service technician. You should only perform troubleshooting and simple repairs as authorized in your product documentation, or as directed by the online or telephone service and support team. Damage due to servicing that is not authorized by Dell is not covered by your warranty. Read and follow the safety instructions that are shipped with your product.

NOTE: The expansion card riser 1 and the x16 link on the riser 2 slot can be used only when both the processors are installed.

1. Holding the touch points, lift the expansion card riser from the riser connector on the systemboard.

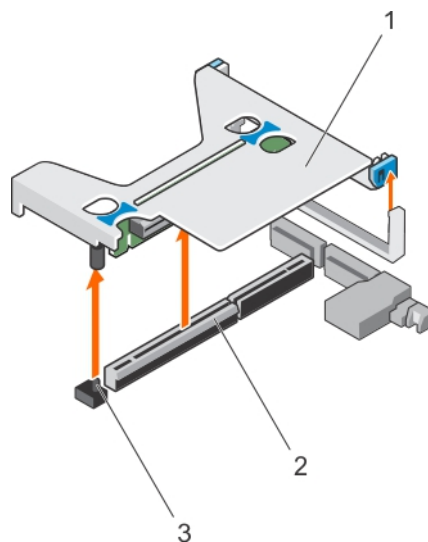

Figure 47. Removing the expansion card riser 1

- a. expansion card riser 1
- b. connector
- c. riser guide pin

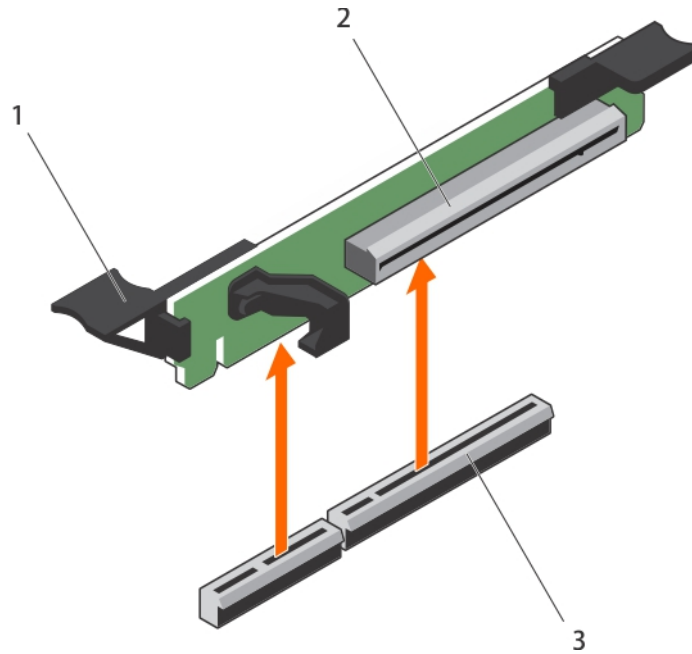

Figure 48. Removing the expansion card riser 3

- a. expansion card release latch
- b. expansion card riser 3
- c. connector

2. If applicable, remove or install an expansion card on the riser.
3. Install the expansion card riser.

Follow the procedure listed in the After working inside your system section.

Related references

[Safety instructions](#)

Related tasks

[Before working inside your system](#)

[Installing an expansion card](#)

[Installing expansion card risers](#)

[After working inside your system](#)

Removing an expansion card

1. Follow the safety guidelines listed in the Safety instructions section.
2. Follow the procedure listed in the Before working inside your system section.

CAUTION: Many repairs may only be done by a certified service technician. You should only perform troubleshooting and simple repairs as authorized in your product documentation, or as directed by the online or telephone service and support team. Damage due to servicing that is not authorized by Dell is not covered by your warranty. Read and follow the safety instructions that are shipped with your product.

1. Disconnect any cables connected to the expansion card or expansion card riser.
2. To remove the expansion card, lift the expansion card latch.
3. Hold the expansion card by its edges and remove it from the expansion card connector on the riser.
4. If you are removing the card permanently, install a metal filler bracket over the empty expansion slot opening and close the expansion card latch.

NOTE: You must install filler bracket over an empty expansion card slot to maintain Federal Communications Commission (FCC) certification of the system. The brackets also keep dust and dirt out of the system and aid in proper cooling and airflow inside the system.

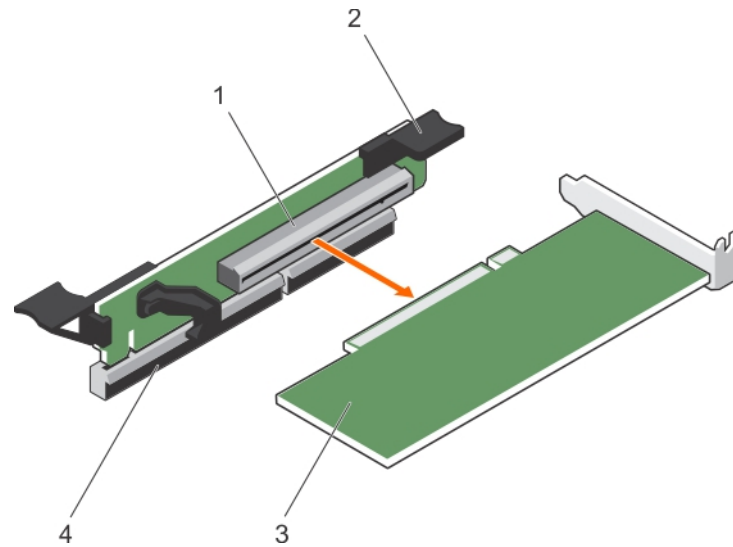

Figure 49. Removing an expansion card

- | | |
|-----------------------------|---|
| 1. expansion card connector | 2. expansion card latch |
| 3. expansion card | 4. expansion card connector on the system board |

Follow the procedure listed in the After working inside your system section.

Related references

[Safety instructions](#)

Related tasks

[Before working inside your system](#)

[After working inside your system](#)

[Installing an expansion card](#)

Installing an expansion card

CAUTION: Many repairs may only be done by a certified service technician. You should only perform troubleshooting and simple repairs as authorized in your product documentation, or as directed by the online or telephone service and support team. Damage due to servicing that is not authorized by Dell is not covered by your warranty. Read and follow the safety instructions that are shipped with your product.

NOTE: The expansion card riser 1 and the x16 link on the riser 2 slot can be used only when both the processors are installed.

1. Follow the safety guidelines listed in the Safety instructions section.
2. Follow the procedure listed in the Before working inside your system section.
3. Remove the expansion card riser.
 1. Unpack the expansion card and prepare it for installation.
For instructions, see the documentation that accompanied the card.
 2. Locate the expansion card connector on the system board or riser.
 3. Open the expansion card latch and remove the filler bracket.
 4. Holding the card by its edges, position the card so that the card edge connector aligns with the expansion card connector.
 5. Insert the card edge connector firmly into the expansion card connector until the card is fully seated.

- Slide the expansion card latch into position.

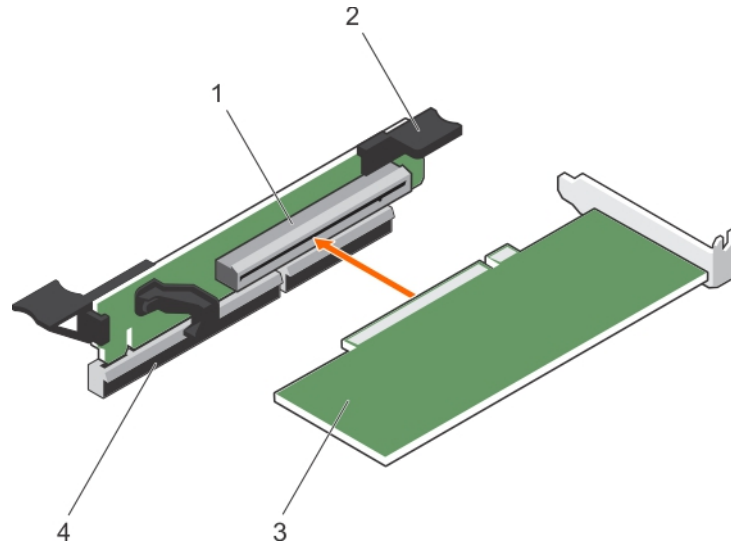

Figure 50. Installing an expansion card

- | | |
|-----------------------------|---|
| 1. expansion card connector | 2. expansion card latch |
| 3. expansion card | 4. expansion card connector on the system board |

- Follow the procedure listed in the After working inside your system section.
- Install any device drivers needed for the card as described in the documentation for the card.

Related tasks

- [Removing expansion card risers](#)
- [After working inside your system](#)
- [Removing an expansion card](#)

Installing expansion card risers

CAUTION: Many repairs may only be done by a certified service technician. You should only perform troubleshooting and simple repairs as authorized in your product documentation, or as directed by the online or telephone service and support team. Damage due to servicing that is not authorized by Dell is not covered by your warranty. Read and follow the safety instructions that are shipped with your product.

- Follow the safety guidelines listed in the Safety instructions section.
- Follow the procedure listed in the Before working inside your system section.
 - If removed, install the expansion cards into the expansion card riser.
 - Align the expansion card riser with the connector and the riser guide pin on the system board.
 - Lower the expansion card riser into place until the expansion card riser connector is fully seated in the connector.

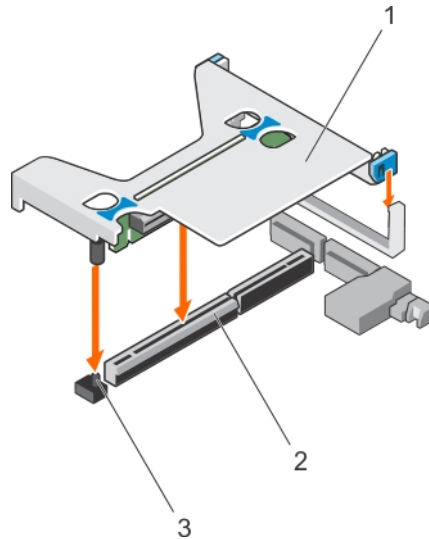

Figure 51. Installing the expansion card riser 1

- a. expansion card riser 1
- b. connector
- c. riser guide pin

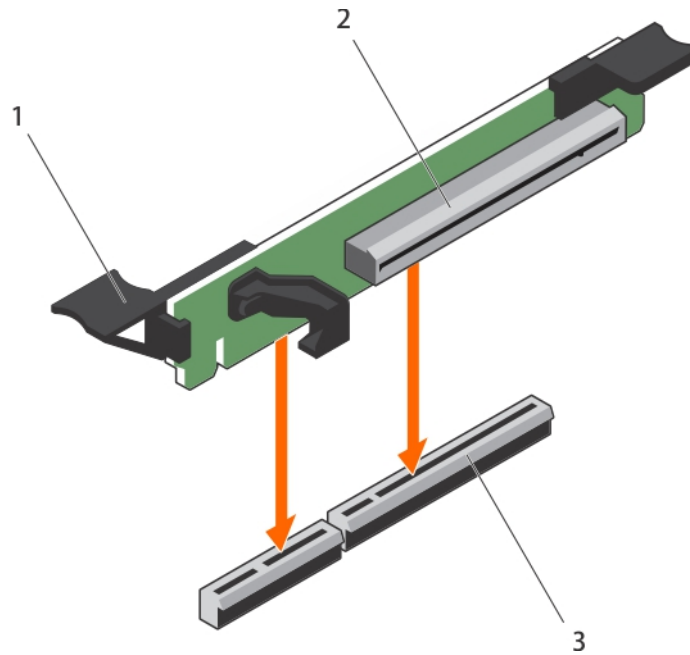

Figure 52. Installing the expansion card riser 3

- a. expansion card release latch
- b. expansion card riser 3
- c. connector

1. Follow the procedure listed in the After working inside your system section.
2. Install any device drivers needed for the card as described in the documentation for the card.

Related tasks

- [Installing an expansion card](#)
- [After working inside your system](#)
- [Removing expansion card risers](#)

SD vFlash card (optional)

An SD vFlash card is a Secure Digital (SD) card that plugs into the SD vFlash card slot in the iDRAC port card. It provides persistent on-demand local storage and a custom deployment environment that enables automation of server configuration, scripts, and imaging. It emulates USB device(s). For more information, see the Integrated Dell Remote Access Controller User's Guide at Dell.com/idracmanuals.

Replacing an SD vFlash card

NOTE: This procedure applies only to the eight hard drive system.

1. Locate the vFlash media slot on the system.
2. To remove the installed SD vFlash card, push inward on the card to release it and pull the card from the card slot.

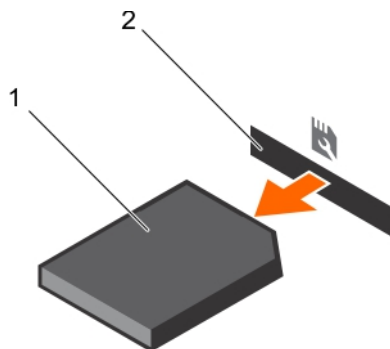

Figure 53. Removing the SD vFlash card

- a. SD vFlash card
- b. SD vFlash card slot

3. To install the SD vFlash card, with the label side facing up, insert the contact-pin end of the SD card into the card slot on the module.

NOTE: The slot is keyed to ensure correct insertion of the card.

4. Press inward on the card to lock it into the slot.

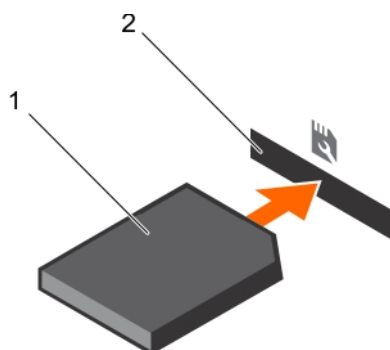

Figure 54. Installing the SD vFlash card

- a. SD vFlash card
- b. SD vFlash card slot

IDSDM

The Internal Dual SD module (IDSDM) provides you with a redundant SD card solution. You can configure the IDSDM for storage or as the OS boot partition. The IDSDM card offers the following features:

- Dual card operation — maintains a mirrored configuration by using SD cards in both the slots and provides redundancy.

NOTE: When the **Redundancy** option is set to **Mirror Mode** in the **Integrated Devices** screen of System Setup, the information is replicated from one SD card to another.

- Single card operation — single card operation is supported, but without redundancy.

Removing an internal SD Card

CAUTION: Many repairs may only be done by a certified service technician. You should only perform troubleshooting and simple repairs as authorized in your product documentation, or as directed by the online or telephone service and support team. Damage due to servicing that is not authorized by Dell is not covered by your warranty. Read and follow the safety instructions that are shipped with your product.

1. Follow the safety guidelines listed in the Safety instructions section.
2. Follow the procedure listed in the Before working inside your system section.

Locate the SD card slot on the internal dual SD module or the backplane expander board and press inward on the card to release it from the slot and remove the card.

Follow the procedure listed in the After working inside your system section.

Related references

[Safety instructions](#)

Related tasks

[Before working inside your system](#)

[After working inside your system](#)

[Installing an internal SD card](#)

Installing an internal SD card

CAUTION: Many repairs may only be done by a certified service technician. You should only perform troubleshooting and simple repairs as authorized in your product documentation, or as directed by the online or telephone service and support team. Damage due to servicing that is not authorized by Dell is not covered by your warranty. Read and follow the safety instructions that are shipped with your product.

1. Follow the safety guidelines listed in the Safety instructions section.
2. Follow the procedure listed in the Before working inside your system section.

NOTE: To use an SD card with your system, ensure that the internal SD card port is enabled in the System Setup.

1. Locate the SD card connector on the internal dual SD module or the backplane expander board. With the label side facing up, insert the contact-pin end of the card into the slot.

NOTE: The slot is keyed to ensure correct insertion of the card.

2. To lock the card into place, press it into the card slot.

Follow the procedure listed in the After working inside your system section.

Related references

[Safety instructions](#)

Related tasks

[Before working inside your system](#)

[After working inside your system](#)

[Removing an internal SD Card](#)

Removing the optional internal dual SD module

CAUTION: Many repairs may only be done by a certified service technician. You should only perform troubleshooting and simple repairs as authorized in your product documentation, or as directed by the online or telephone service and support team. Damage due to servicing that is not authorized by Dell is not covered by your warranty. Read and follow the safety instructions that are shipped with your product.

1. Follow the safety guidelines listed in the Safety instructions section.
2. Follow the procedure listed in the Before working inside your system section.
3. If installed, remove the SD cards.
 - NOTE:** Temporarily label each SD card with its corresponding slot number before removal. Reinstall the SD cards into the corresponding slots.
1. Locate the internal dual SD module (IDSDM) on the system board. To locate the internal dual SD module connector, see the System board connectors section.
2. Holding the pull tab, lift the IDSDM out of the system.

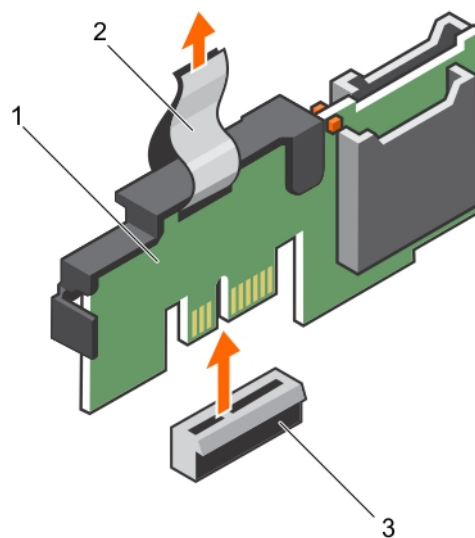

Figure 55. Removing the internal dual SD module (IDSDM)

- a. IDSDM
- b. pull tab
- c. IDSDM connector

The following table describes the IDSDM indicator codes:

Table 39. IDSDM indicator codes

Convention	IDSDM indicator code	Description
A	Green	Indicates that the card is online.
B	Flashing green	Indicates rebuild or activity.
C	Flashing amber	Indicates card mismatch or that the card has failed.
D	Amber	Indicates that the card is offline, has failed, or is write protected.
E	Not lit	Indicates that the card is missing or is booting.

1. Install the IDSDM.
2. If removed, install the SD cards.
3. Follow the procedure listed in the After working inside your system section.

Related references

[Safety instructions](#)

Related tasks

[Before working inside your system](#)

[Removing an internal SD Card](#)

[Installing the optional internal dual SD module](#)

[After working inside your system](#)

Installing the optional internal dual SD module

CAUTION: Many repairs may only be done by a certified service technician. You should only perform troubleshooting and simple repairs as authorized in your product documentation, or as directed by the online or telephone service and support team. Damage due to servicing that is not authorized by Dell is not covered by your warranty. Read and follow the safety instructions that are shipped with your product.

1. Follow the safety guidelines listed in the Safety instructions section.
2. Follow the procedure listed in the Before working inside your system section.
 - NOTE:** Temporarily label each SD card with its corresponding slot before removal.
1. Locate the internal dual SD module (IDSDM) connector on the system board. To locate the IDSDM connector, see the System board connectors section.
2. Align the IDSDM with the connector on the system board.
3. Push the IDSDM until it is firmly seated on the system board.
1. Install the SD cards.
 - NOTE:** Re-install the SD cards into the same slots based on the labels you had marked on the cards during removal.
2. Follow the procedure listed in the After working inside your system section.

Related references

[Safety instructions](#)

[System board jumpers and connectors](#)

Related tasks

[Before working inside your system](#)

[After working inside your system](#)

[Removing the optional internal dual SD module](#)

Integrated storage controller card

Your system includes a dedicated expansion card slot on the system board for an integrated storage controller card. The integrated storage controller card provides the integrated storage subsystem for the internal hard drives in your system. The controller supports SAS and SATA hard drives and also enables you to set up the hard drives in RAID configurations. The RAID configurations depend on the version of the storage controller included with your system. The controller supports SAS hard drives.

Removing the integrated storage controller card

CAUTION: Many repairs may only be done by a certified service technician. You should only perform troubleshooting and simple repairs as authorized in your product documentation, or as directed by the online or telephone service and support team. Damage due to servicing that is not authorized by Dell is not covered by your warranty. Read and follow the safety instructions that are shipped with your product.

1. Follow the safety guidelines listed in the Safety instructions section.

2. Follow the procedure listed in the Before working inside your system section.
3. Remove the cooling shroud.
4. Keep the Phillips #2 screwdriver ready.
1. Loosen the screws that secure the integrated storage controller cable to the integrated storage controller card connector on the system board.
2. Lift the integrated storage controller cable away from the integrated storage controller.
3. Lift one end of the card and angle it to disengage the card from the integrated storage controller card holder on the system board.
4. Lift the card out of the system.

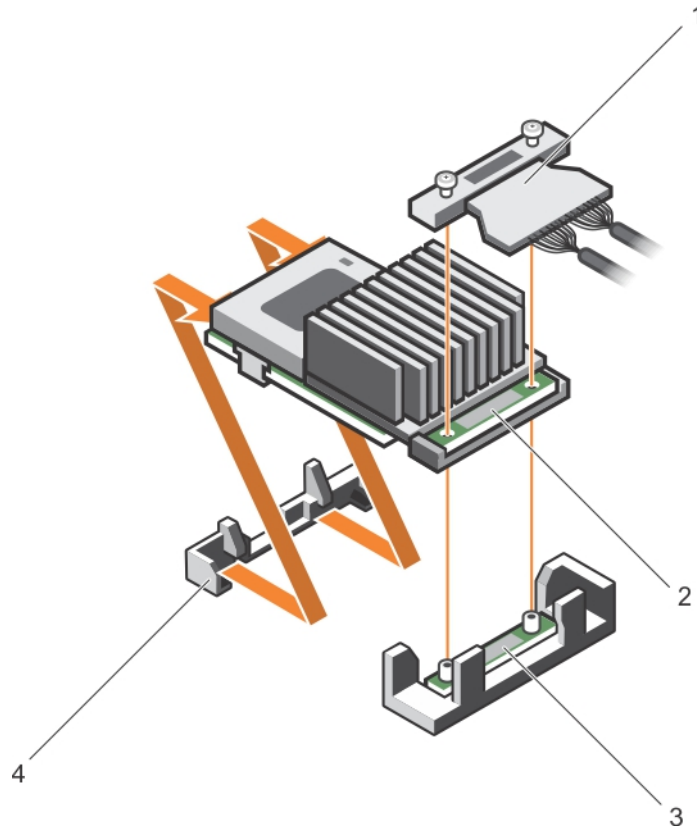

Figure 56. Removing the integrated storage controller card

- | | |
|---|--|
| 1. integrated storage controller cable | 2. integrated storage controller card |
| 3. integrated storage controller card connector on the system board | 4. integrated storage controller card holder |

1. Install the cooling shroud.
2. Installing the integrated storage controller card.
3. Follow the procedure listed in the After working inside your system section.

Related references

[Safety instructions](#)

Related tasks

- [Before working inside your system](#)
- [Removing the cooling shroud](#)
- [Removing expansion card risers](#)
- [Installing expansion card risers](#)
- [Installing the cooling shroud](#)
- [After working inside your system](#)
- [Installing the integrated storage controller card](#)

Installing the integrated storage controller card

CAUTION: Many repairs may only be done by a certified service technician. You should only perform troubleshooting and simple repairs as authorized in your product documentation, or as directed by the online or telephone service and support team. Damage due to servicing that is not authorized by Dell is not covered by your warranty. Read and follow the safety instructions that are shipped with your product.

1. Follow the safety guidelines listed in the Safety instructions section.
 2. Follow the procedure listed in the Before working inside your system section.
 3. Remove the cooling shroud.
 4. Keep the Phillips #2 screwdriver ready.
1. Align the end of the integrated storage controller card with the controller card connector on the system board.
 2. Lower the connector side of the integrated storage controller card into the integrated storage controller card connector on the system board.

NOTE: Ensure that the tabs on the system board align with the screw holes on the integrated storage controller card.

3. Align the screws on the integrated storage controller card cable with the screw holes on the connector.
4. Tighten the screws to secure the integrated storage controller card cable with the integrated storage controller card connector on the system board.

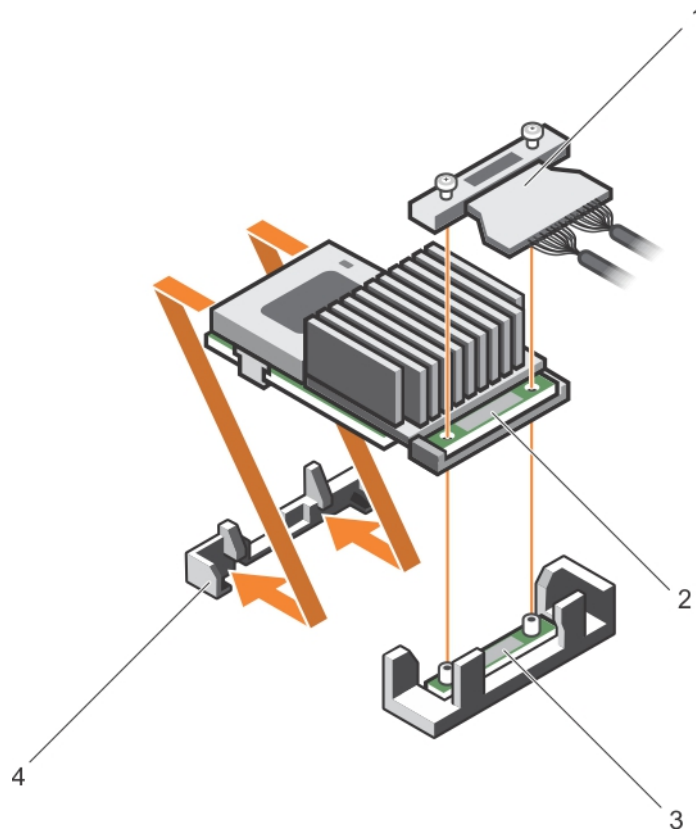

Figure 57. Installing the integrated storage controller card

- | | |
|---|--|
| 1. integrated storage controller cable | 2. integrated storage controller card |
| 3. integrated storage controller card connector on the system board | 4. integrated storage controller card holder |

1. Install the cooling shroud.
2. Follow the procedure listed in the After working inside your system section.

Related references

[Safety instructions](#)

Related tasks

[Before working inside your system](#)
[Removing the cooling shroud](#)
[Removing expansion card risers](#)
[Installing expansion card risers](#)
[Installing the cooling shroud](#)
[After working inside your system](#)
[Removing the integrated storage controller card](#)

Network daughter card

The Network daughter card (NDC) is a small, removable mezzanine card. The NDC provides you with the flexibility of choosing different network connectivity options, for example—4 x 1GbE, 2 x 10GbE and 2 x Converged Network Adapter.

Removing the network daughter card

CAUTION: Many repairs may only be done by a certified service technician. You should only perform troubleshooting and simple repairs as authorized in your product documentation, or as directed by the online or telephone service and support team. Damage due to servicing that is not authorized by Dell is not covered by your warranty. Read and follow the safety instructions that are shipped with your product.

1. Follow the safety guidelines listed in the Safety instructions section.
2. Follow the procedure listed in the Before working inside your system section.
3. Keep the Philips #2 screwdriver handy.
 1. Remove the expansion card riser 3.
 2. Using a Phillips #2 screwdriver, loosen the two captive screws that secure the Network Daughter Card (NDC) to the system board.
 3. Hold the NDC by the edges on either side of the touch points and lift to remove it from the connector on the system board.
 4. Slide the NDC away from the back of the system until the Ethernet connectors are clear of the slot in the back panel.
 5. Lift the NDC out of the system.

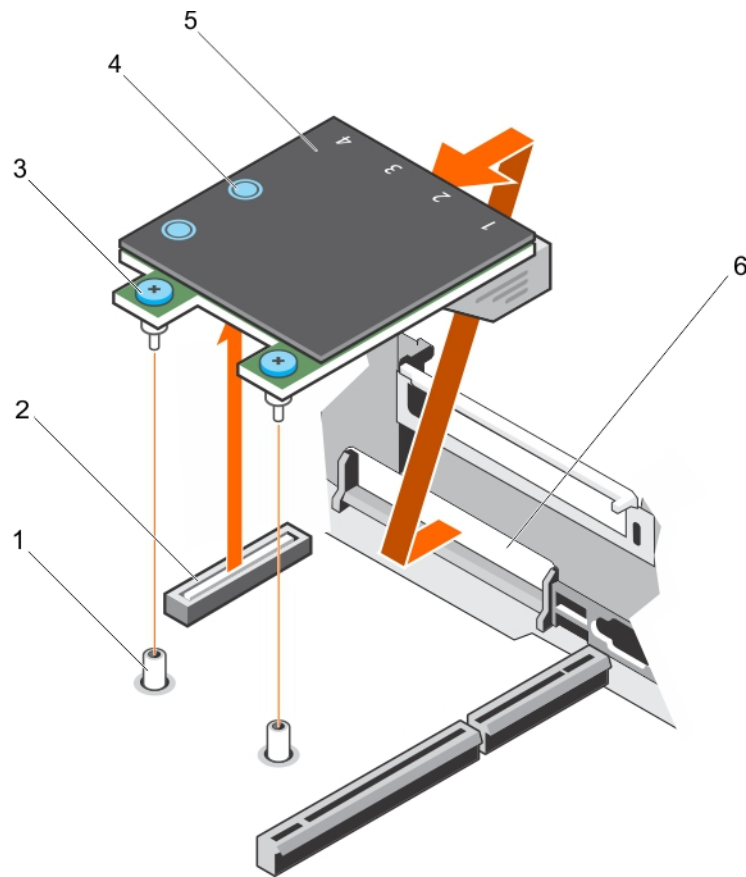

Figure 58. Removing the NDC

- | | |
|---|---|
| <ol style="list-style-type: none"> 1. captive screw socket (2) 3. captive screw (2) 5. NDC | <ol style="list-style-type: none"> 2. connector on the system board 4. touch point (2) 6. back panel slots for Ethernet connectors |
|---|---|

Related references

[Safety instructions](#)

Related tasks

[Before working inside your system](#)

[Removing expansion card risers](#)

[Installing the network daughter card](#)

Installing the network daughter card

CAUTION: Many repairs may only be done by a certified service technician. You should only perform troubleshooting and simple repairs as authorized in your product documentation, or as directed by the online or telephone service and support team. Damage due to servicing that is not authorized by Dell is not covered by your warranty. Read and follow the safety instructions that are shipped with your product.

CAUTION: If the GPU card is installed, you cannot install the 10 GbE Network Daughter Card (NDC).

1. Follow the safety guidelines listed in the Safety instructions section.
2. Follow the procedure listed in the Before working inside your system section.
3. Keep the Philips #1 screwdriver handy.

NOTE: If the system has three PCIe cards, ensure that you install the PCIe cooling shroud in your system.

1. Orient the NDC so that the Ethernet connectors fit through the slot in the back panel.
2. Align the captive screws at the back-end of the card with the screw holes on the system board.
3. To ensure that the connector on the card is in contact with the connector on the system board, press the touch point on the card.
4. Tighten the two captive screws to secure the NDC to the system board.
5. Install the expansion card riser 3.

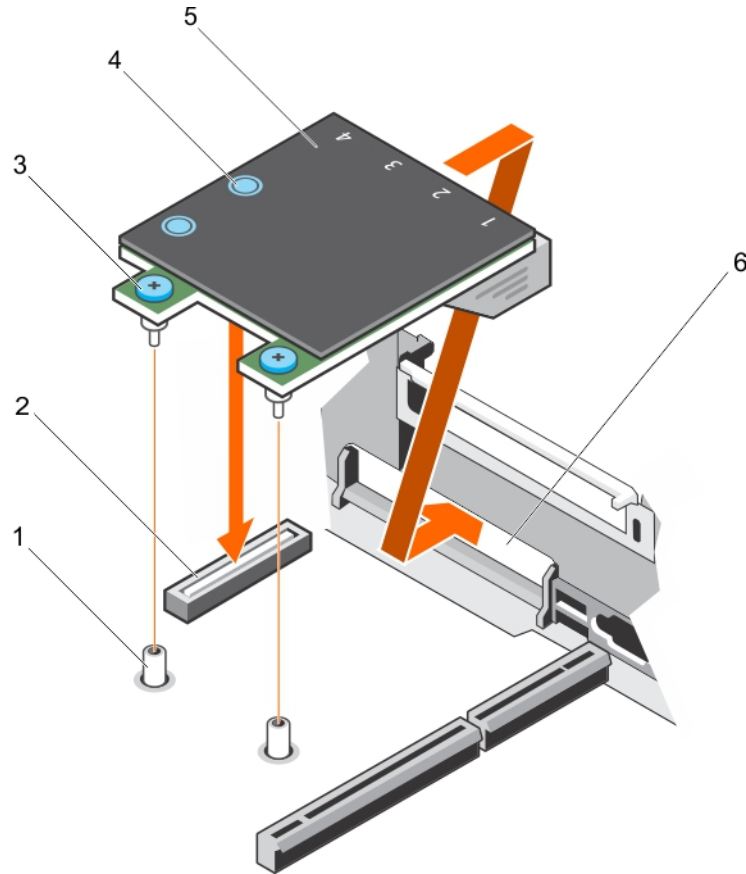

Figure 59. Installing the NDC

- | | |
|-----------------------------|---|
| 1. captive screw socket (2) | 2. connector on the system board |
| 3. captive screw (2) | 4. touch point (2) |
| 5. NDC | 6. back panel slots for Ethernet connectors |

Follow the procedure listed in the After working inside your system section.

Related references

[Safety instructions](#)

Related tasks

[Before working inside your system](#)

[Installing expansion card risers](#)

[After working inside your system](#)

[Removing the network daughter card](#)

Processors and heat sinks

Use the following procedures when:

- Removing and installing a heat sink

- Installing an additional processor
- Replacing a processor

NOTE: To ensure proper cooling, you must install a processor blank in any empty processor socket.

Removing a heat sink

CAUTION: Never remove the heat sink from a processor unless you intend to remove the processor. The heat sink is necessary to maintain proper thermal conditions.

WARNING: The heat sink is hot to touch. Allow the heat sink to cool for some time after powering down the system.

1. Follow the safety guidelines listed in the Safety instructions section.
 2. Follow the procedure listed in the Before working inside your system section.
 3. If installed, remove the full-length PCIe card(s).
 4. Remove the cooling shroud.
 5. Keep the Phillips #2 screwdriver ready.
1. Loosen one of the screws that secure the heat sink to the system board.
Allow some time (approximately 30 seconds) for the heat sink to loosen from the processor.
 2. Remove the screw diagonally opposite to the screw that you first removed.
 3. Repeat step 1 and 2 for removing the remaining two screws.
 4. Remove the heat sink.

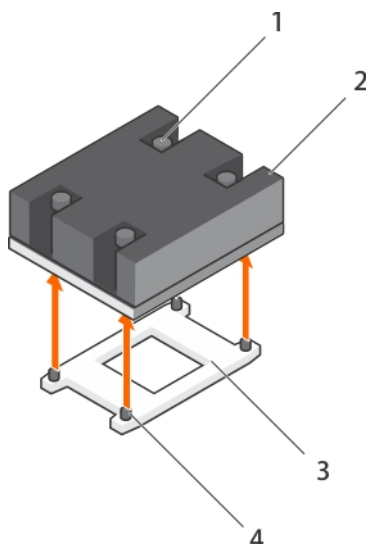

Figure 60. Removing a heat sink

- | | |
|------------------------|-----------------------------|
| 1. retention screw (4) | 2. heat sink |
| 3. processor socket | 4. retention screw slot (4) |

1. Replace the heat sink(s) and processor(s).
2. Replace the processor and heat sink.
3. Follow the procedure listed in the After working inside your system section.

Related references

[Safety instructions](#)

Related tasks

[Before working inside your system](#)

[Removing the cooling shroud](#)

Removing a processor

CAUTION: Many repairs may only be done by a certified service technician. You should only perform troubleshooting and simple repairs as authorized in your product documentation, or as directed by the online or telephone service and support team. Damage due to servicing that is not authorized by Dell is not covered by your warranty. Read and follow the safety instructions that are shipped with your product.

NOTE: This is a Field Replaceable Unit (FRU). Removal and installation procedures should be performed only by Dell certified service technicians.

NOTE: If you are upgrading your system, download the latest system BIOS version from **Dell.com/support** and follow the instructions included in the compressed download file to install the update on your system.



NOTE: You can update the system BIOS by using the Dell Lifecycle Controller.

NOTE: To ensure proper system cooling, you must install a processor blank in any empty processor socket.

1. Follow the safety guidelines listed in the Safety instructions section.
2. Follow the procedure listed in the Before working inside your system section.
3. Keep the Phillips #2 screwdriver ready.
4. If installed, remove the full-length PCIe card(s).
5. Remove the cooling shroud.
6. Remove the heat sink.

WARNING: The processor is hot to touch for some time after the system has been powered down. Allow the processor to cool before removing it.

CAUTION: The processor is held in its socket under strong pressure. Be aware that the release lever can spring up suddenly if not firmly grasped.

1. Release the *open first* socket lever near the unlock icon  by pushing the lever down and out from under the tab.
2. Release the *close first* socket release lever near the lock icon  by pushing the lever down and out from under the tab. Lift the lever 90 degrees upward.
3. Lower the *open first* socket-release lever to lift the processor shield.
4. Hold the tab on the processor shield and lift the processor shield until the *open first* socket-release lever lifts up.

CAUTION: The socket pins are fragile and can be permanently damaged. Be careful not to bend the pins in the socket when removing the processor out of the socket.

5. Lift the processor out of the socket and leave the *open first* socket-release lever up.

NOTE: If you are permanently removing the processor, you must install a socket protective cap in the vacant socket to protect the socket pins and keep the socket free of dust.

NOTE: After removing the processor, place it in an anti-static container for reuse, return, or temporary storage. Do not touch the bottom of the processor. Touch only the side edges of the processor.

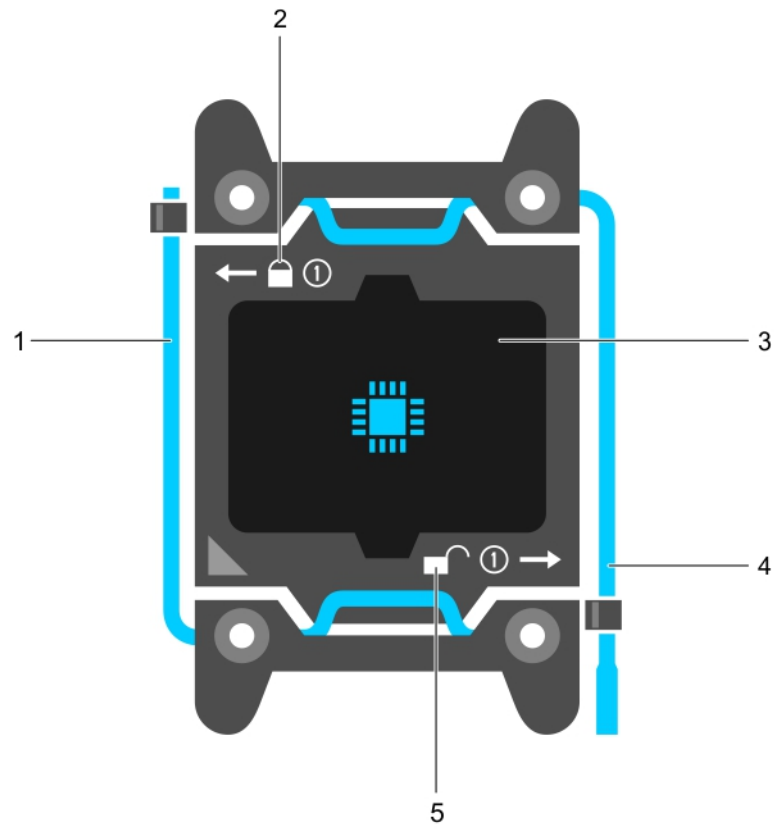

Figure 61. Processor shield

- 1. *close first* socket release lever
- 2. lock icon
- 3. processor
- 4. *open first* socket release lever
- 5. unlock icon

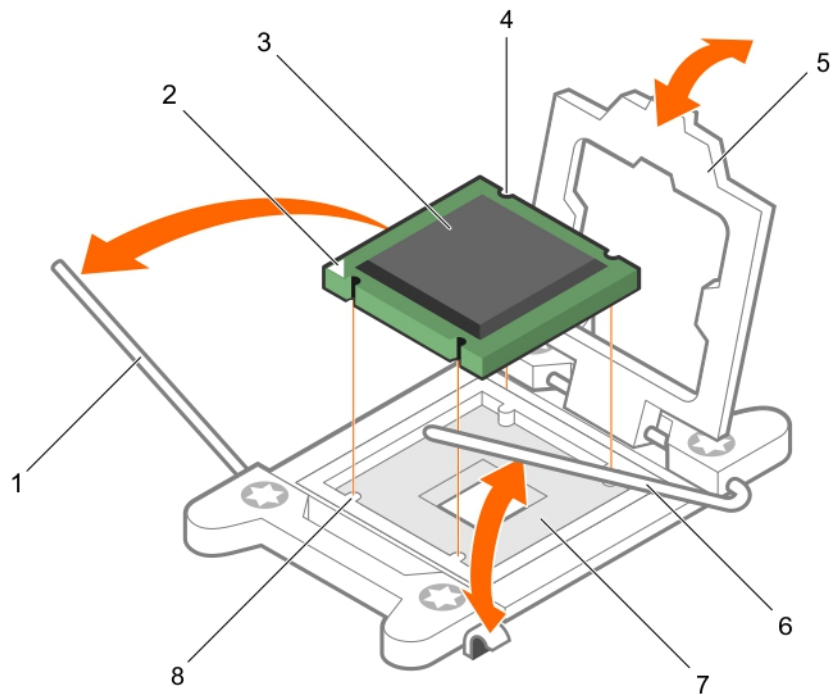

Figure 62. Removing a processor

- | | |
|--|---|
| 1. <i>close first</i> socket-release lever | 2. pin-1 indicator of processor |
| 3. processor | 4. slot (4) |
| 5. processor shield | 6. <i>open first</i> socket-release lever |
| 7. socket | 8. socket keys (4) |

1. Replace the processor(s).
2. Install the heat sink.
3. Reinstall the cooling shroud.
4. Follow the procedure listed in the After working inside your system section.

Related references

[Safety instructions](#)

Related tasks

[Before working inside your system](#)

[Removing the cooling shroud](#)

[Removing a heat sink](#)

[Installing a processor](#)

[Installing a heat sink](#)

[Installing the cooling shroud](#)

[After working inside your system](#)

Installing a processor

CAUTION: Many repairs may only be done by a certified service technician. You should only perform troubleshooting and simple repairs as authorized in your product documentation, or as directed by the online or

telephone service and support team. Damage due to servicing that is not authorized by Dell is not covered by your warranty. Read and follow the safety instructions that are shipped with your product.

i **NOTE:** This is a Field Replaceable Unit (FRU). Removal and installation procedures should be performed only by Dell certified service technicians.

1. Follow the safety guidelines listed in the Safety instructions section.
2. Follow the procedure listed in the Before working inside your system section.
3. Keep the Phillips #2 screwdriver ready.
4. If you are upgrading your system, download the latest system BIOS version from **Dell.com/support** and follow the instructions included in the compressed download file to install the update on your system.

i **NOTE:** You can also update the system BIOS by using the Dell Lifecycle Controller.

5. If installed, remove the full-length PCIe card.
6. Remove the cooling shroud.

i **NOTE:** If applicable, close the expansion card latch on the cooling shroud to release the full length card.



i **NOTE:** The heat sink and processor are too hot to touch for some time after the system has been powered down. Allow the heat sink and processor to cool down before handling them.

△ **CAUTION: Never remove the heat sink from a processor unless you intend to remove the processor. The heat sink is necessary to maintain proper thermal conditions.**

i **NOTE:** If you are installing a single processor, it must be installed in socket CPU1.

1. Unpack the new processor.

i **NOTE:** If the processor has previously been used in a system, remove any remaining thermal grease from the processor by using a lint-free cloth.



2. Locate the processor socket.
3. If applicable, remove the socket protective cap.
4. Release the *open first* socket-release lever near the unlock icon  by pushing the lever down and out from under the tab.
5. Similarly, release the *close first* socket-release lever near the lock icon  by pushing the lever down and out from under the tab. Lift the lever 90 degrees upward.
6. Hold the tab near the lock symbol on the processor shield and lift it up and out of the way.

△ **CAUTION: Positioning the processor incorrectly can permanently damage the system board or the processor. Be careful not to bend the pins in the socket.**

△ **CAUTION: While removing or reinstalling the processor, wipe your hands of any contaminants. Contaminants on the processor pins such as thermal grease or oil can damage the processor.**

7. Align the processor with the socket keys.

△ **CAUTION: Do not use force to seat the processor. When the processor is positioned correctly, it engages easily into the socket.**

8. Align the pin-1 indicator of the processor with the triangle on the system board.
9. Place the processor on the socket such that the slots on the processor align with the socket keys.
10. Close the processor shield.
11. Lower the *close first* socket-release lever near the lock icon  and push it under the tab to lock it.
12. Similarly, lower the *open first* socket-release lever near the unlock icon  and push it under the tab to lock it.

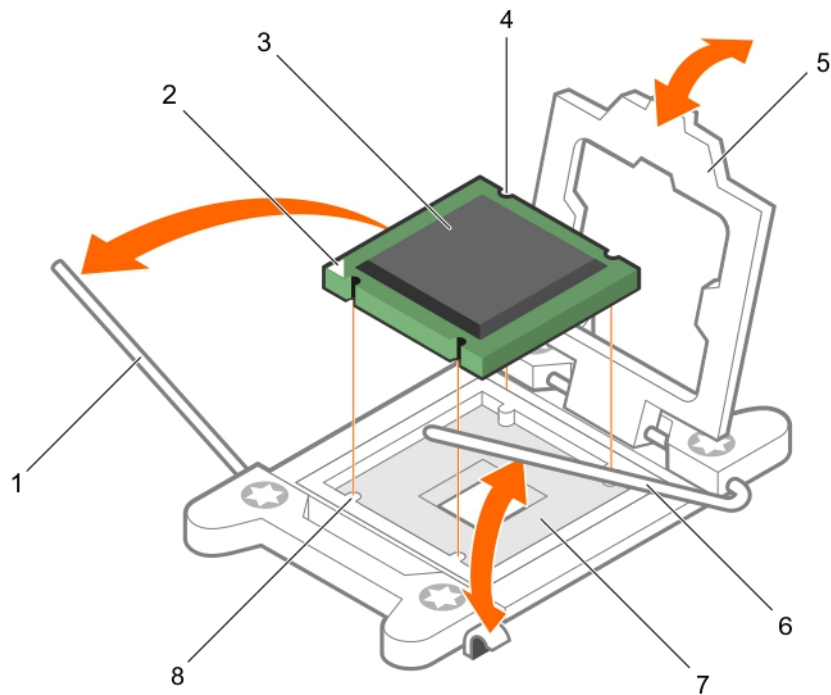

Figure 63. Installing a processor

- | | |
|---------------------------|----------------------------------|
| 1. socket-release lever 1 | 2. pin-1 corner of the processor |
| 3. processor | 4. slot (4) |
| 5. processor shield | 6. socket-release lever 2 |
| 7. processor socket | 8. tab (4) |

NOTE: Ensure that you install the heat sink after you install the processor. The heat sink is necessary to maintain proper thermal conditions.

1. Install the heat sink.
2. Follow the procedure listed in the [After working inside your system](#).
3. While booting, press F2 to enter System Setup and verify that the processor information matches the new system configuration.
4. Run the system diagnostics to verify that the new processor operates correctly.

Related concepts

[System Setup](#)

Related references

[Safety instructions](#)

[Using system diagnostics](#)

Related tasks

[Before working inside your system](#)

[Removing the cooling shroud](#)

[Installing a heat sink](#)

Installing a heat sink

CAUTION: Many repairs may only be done by a certified service technician. You should only perform troubleshooting and simple repairs as authorized in your product documentation, or as directed by the online or telephone service and support team. Damage due to servicing that is not authorized by Dell is not covered by your warranty. Read and follow the safety instructions that are shipped with your product.

1. Follow the safety guidelines listed in the Safety instructions section.
 2. Follow the procedure listed in the Before working inside your system section.
 3. Remove the cooling shroud.
 4. Install the processor.
 5. Keep the Phillips #2 screwdriver ready.
1. If you are using an existing heat sink, remove the thermal grease from the heat sink by using a clean lint-free cloth.
 2. Use the thermal grease syringe included with your processor kit to apply the grease in a thin spiral on the top of the processor.

CAUTION: Applying too much thermal grease can result in excess grease coming in contact with and contaminating the processor socket.

NOTE: The thermal grease syringe is intended for one-time use only. Dispose of the syringe after you use it.

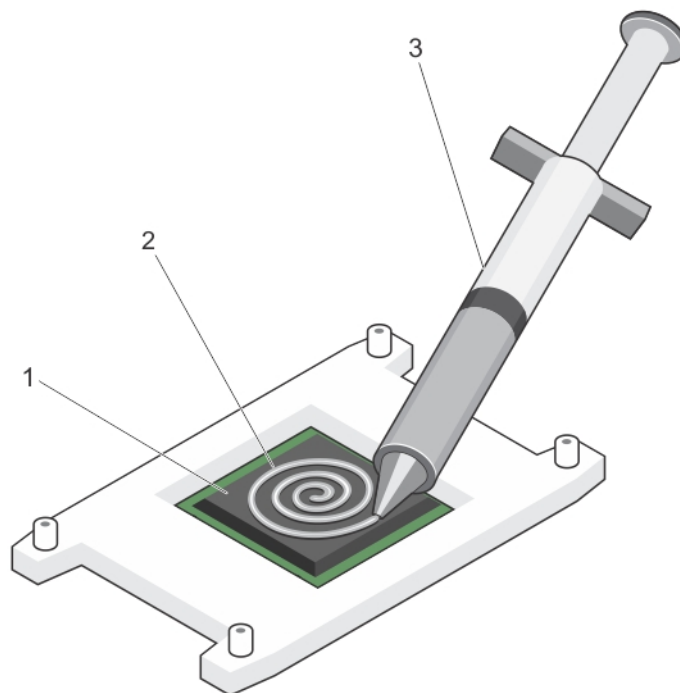

Figure 64. Applying thermal grease on the top of the processor

- a. processor
 - b. thermal grease
 - c. thermal grease syringe
3. Place the heat sink onto the processor.
 4. Tighten one of the four screws to secure the heat sink to the system board.
 5. Repeat the procedure for the remaining two screws.

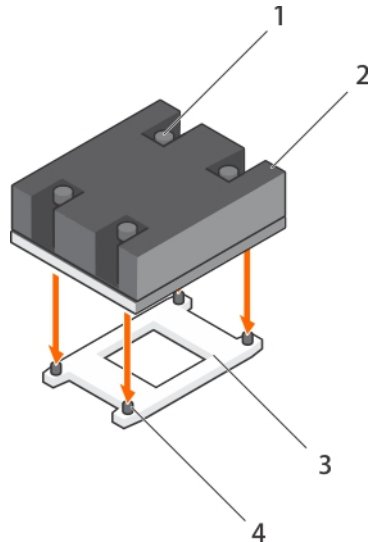

Figure 65. Installing the heat sink

- | | |
|------------------------|-----------------------------|
| 1. retention screw (4) | 2. heat sink |
| 3. processor socket | 4. retention screw slot (4) |

1. Install the cooling shroud.
2. If applicable, install the PCIe card.
3. Follow the procedure listed in the After working inside your system section.
4. While booting, press F2 to enter System Setup and verify that the processor information matches the new system configuration.
5. Run the system diagnostics to verify that the new processor operates correctly.

Related references

[Safety instructions](#)

Related tasks

[Before working inside your system](#)

[Removing the cooling shroud](#)

[Installing a processor](#)

[Installing the cooling shroud](#)

[After working inside your system](#)

Power supply units (PSU)

Your system supports one of the following:

- Two 495 W, 750 W, or 1100 W AC power supply units (PSUs)
- Two 1100 W DC PSUs
- Two 750 W mixed mode PSUs
- Two 750 W or 1100 W AC power supply units (PSUs)

CAUTION: For AC PSUs, use only PSUs with the Extended Power Performance (EPP) label on the back. Mixing PSUs from previous generations of systems can result in a PSU mismatch condition or failure to turn on.

NOTE: Titanium PSU is nominally rated for 200 V AC to 240 V AC input only.

NOTE: When two identical PSUs are installed, power supply redundancy (1+1 – with redundancy or 2+0 – without redundancy) is configured in system BIOS. In redundant mode, power is supplied to the system equally from both PSUs when Hot Spare is disabled. When Hot Spare is enabled, one of the PSUs will be put into standby when system utilization is low to maximize efficiency.

NOTE: If two PSUs are used, they must be of the same maximum output power.

Hot spare feature

Your system supports the hot spare feature that significantly reduces the power overhead associated with power supply unit (PSU) redundancy.

When the hot spare feature is enabled, one of the redundant PSUs is switched to the sleep state. The active PSU supports 100 percent of the load, thus operating at higher efficiency. The PSU in the sleep state monitors output voltage of the active PSU. If the output voltage of the active PSU drops, the PSU in the sleep state returns to an active output state.

If having both PSUs active is more efficient than having one PSU in the sleep state, the active PSU can also activate the sleeping PSU.

The default PSU settings are as follows:

- If the load on the active PSU is more than 50 percent, then the redundant PSU is switched to the active state.
- If the load on the active PSU falls below 20 percent, then the redundant PSU is switched to the sleep state.

You can configure the hot spare feature by using the iDRAC settings. For more information about iDRAC settings, see the *Integrated Dell Remote Access Controller User's Guide* available at Dell.com/idracmanuals.

Removing the power supply unit blank

Install the power supply unit (PSU) blank only in the second PSU bay.

CAUTION: Many repairs may only be done by a certified service technician. You should only perform troubleshooting and simple repairs as authorized in your product documentation, or as directed by the online or telephone service and support team. Damage due to servicing that is not authorized by Dell is not covered by your warranty. Read and follow the safety instructions that are shipped with your product.

Follow the safety guidelines listed in the Safety instructions section.

If you are installing a second power supply unit (PSU), remove the PSU blank in the bay by pulling the blank outward.

CAUTION: To ensure proper system cooling, the PSU blank must be installed in the second PSU bay in a non-redundant configuration. Remove the PSU blank only if you are installing a second PSU.

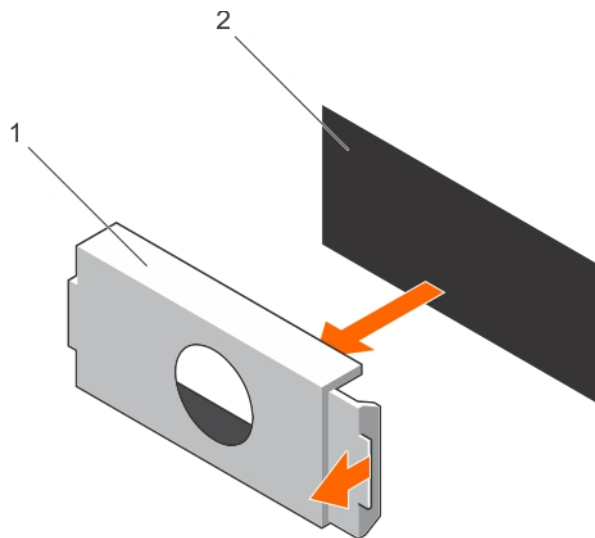

Figure 66. Removing the PSU blank

- a. PSU blank
- b. PSU bay

Install the PSU or PSU blank.

Related tasks

[Installing the power supply unit blank](#)

Installing the power supply unit blank

Install the power supply unit (PSU) blank only in the second PSU bay.

CAUTION: Many repairs may only be done by a certified service technician. You should only perform troubleshooting and simple repairs as authorized in your product documentation, or as directed by the online or telephone service and support team. Damage due to servicing that is not authorized by Dell is not covered by your warranty. Read and follow the safety instructions that are shipped with your product.

1. Follow the safety guidelines listed in the Safety instructions section.

Align the power supply unit blank with the power supply unit slot and push it into the power supply unit slot until it clicks into place.

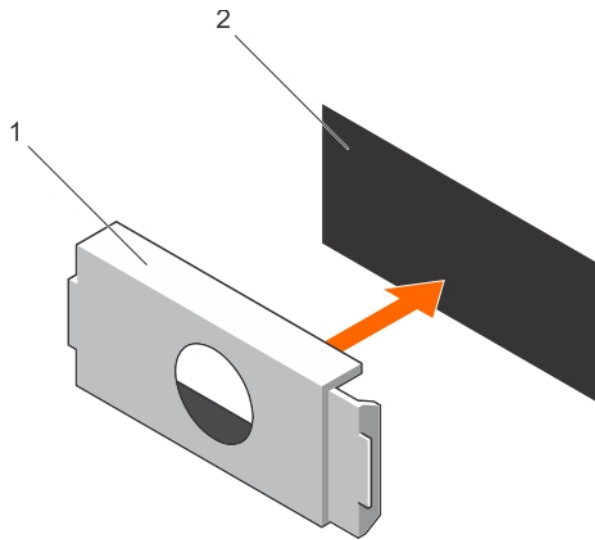

Figure 67. Installing the PSU blank

- a. PSU blank
- b. PSU bay

Related tasks

[Removing the power supply unit blank](#)

Removing an AC power supply unit

CAUTION: Many repairs may only be done by a certified service technician. You should only perform troubleshooting and simple repairs as authorized in your product documentation, or as directed by the online or telephone service and support team. Damage due to servicing that is not authorized by Dell is not covered by your warranty. Read and follow the safety instructions that are shipped with your product.

CAUTION: The system needs one power supply unit (PSU) for normal operation. On power-redundant systems, remove and replace only one PSU at a time in a system that is powered on.

If applicable, unlatch and lift the optional cable management arm if it interferes with the power supply unit (PSU) removal. For information about the cable management arm, see the system's rack documentation.

Follow the safety guidelines listed in the Safety instructions section.

1. Disconnect the power cable from the power source and from the PSU you intend to remove, and then remove the cables from the strap.
2. Press the release latch and slide the PSU out of the chassis by using the PSU handle.

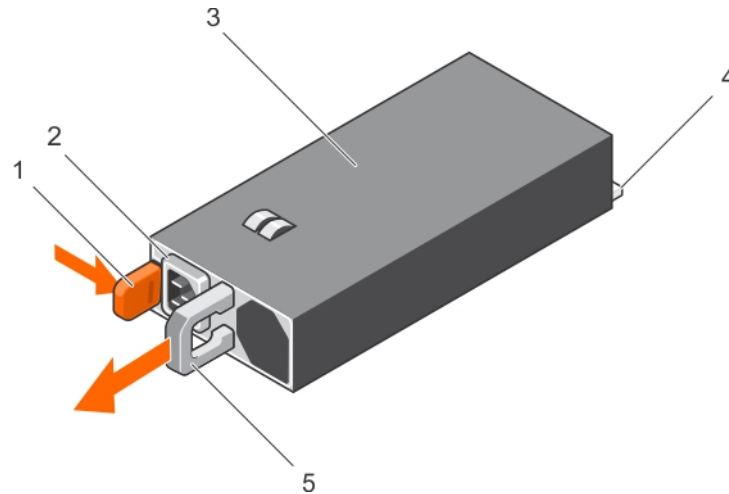

Figure 68. Removing an AC PSU

- | | |
|------------------|------------------------|
| 1. release latch | 2. PSU cable connector |
| 3. PSU | 4. power connector |
| 5. PSU handle | |

- If applicable, install the AC PSU.
- If applicable, install the PSU blank.

Related tasks

[Installing an AC power supply unit](#)

Installing an AC power supply unit

CAUTION: Many repairs may only be done by a certified service technician. You should only perform troubleshooting and simple repairs as authorized in your product documentation, or as directed by the online or telephone service and support team. Damage due to servicing that is not authorized by Dell is not covered by your warranty. Read and follow the safety instructions that are shipped with your product.

NOTE: The maximum output power (shown in watts) is listed on the PSU label.

1. Follow the safety guidelines listed in the Safety instructions section.
2. For systems that support redundant power supply units (PSUs), ensure that both the PSUs are of the same type and have the same maximum output power.
3. If installed, remove the PSU blank.
 1. Slide the PSU into the chassis until the PSU is fully seated and the release latch snaps into place.
 2. If applicable, relatch the cable management arm.
For information about the cable management arm, see the rack documentation of your system.
3. Connect the power cable to the PSU, and plug the cable into a power outlet.

CAUTION: When connecting the power cable, secure the cable with the strap.

NOTE: When installing, hot swapping, or hot-adding a new PSU, wait for 15 seconds for the system to recognize the PSU and determine its status. The PSU redundancy may not occur until discovery is complete. Wait until the new PSU is discovered and enabled before you remove the other PSU. The PSU status indicator turns green to signify that the PSU is functioning properly.

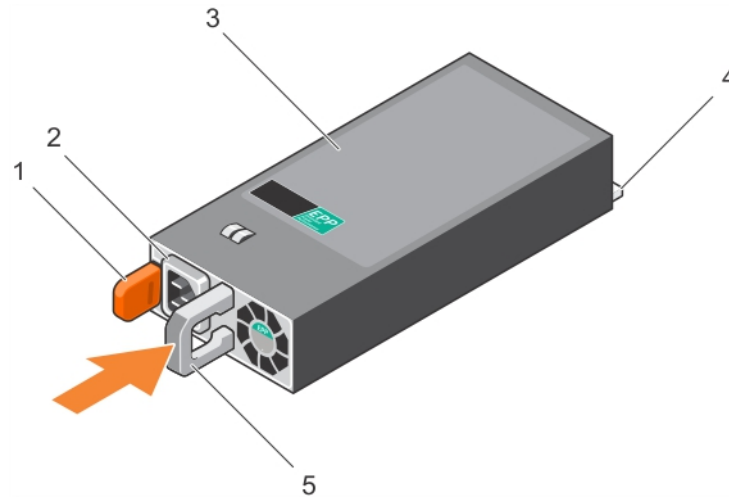

Figure 69. Installing an AC PSU

- | | |
|------------------|------------------------|
| 1. release latch | 2. PSU cable connector |
| 3. PSU | 4. power connector |
| 5. PSU handle | |

Related references

[Safety instructions](#)

Related tasks

[Removing the power supply unit blank](#)

[Removing an AC power supply unit](#)

Wiring instructions for a DC power supply unit

Your system supports up to two $-(48-60)$ V DC power supply units (PSUs).

NOTE: For equipment using $-(48-60)$ V DC power supply units (PSUs), a qualified electrician must perform all connections to DC power and to safety grounds. Do not attempt connecting to DC power or installing grounds yourself. All electrical wiring must comply with applicable local or national codes and practices. Damage due to servicing that is not authorized by Dell is not covered by your warranty. Read and follow all safety instructions that came with the product.

CAUTION: Wire the unit with copper only, unless otherwise specified, use only 10 American Wire Gauge (AWG) wire rated minimum 90 °C for source and return. Protect the $-(48-60)$ V DC (1 wire) with a branch circuit over-current protection rated 50 A for DC with a high interrupt current rating.

CAUTION: Connect the equipment to a $-(48-60)$ V DC supply source that is electrically isolated from the AC source (reliably grounded $-(48-60)$ V DC SELV source). Ensure that the $-(48-60)$ V DC source is efficiently secured to earth (ground).

NOTE: A readily accessible disconnect device that is suitably approved and rated shall be incorporated in the field wiring.

Input requirements

- Supply voltage: $-(48-60)$ V DC
- Current consumption: 32 A (maximum)

Kit contents

- Dell part number 6RYJ9 terminal block or equivalent (1)
- #6-32 nut equipped with lock washer (1)

Required tools

Wire-stripper pliers capable of removing insulation from size 10 AWG solid or stranded, insulated copper wire

NOTE: Use alpha wire part number 3080 or equivalent (65/30 stranding)

Required wires

- One UL 10 AWG, 2 m maximum (stranded) black wire [–(48–60) V DC]
- One UL 10 AWG, 2 m maximum (stranded) red wire (V DC return)
- One UL 10 AWG, 2 m maximum green/yellow, green with a yellow stripe, stranded wire (safety ground)

Assembling and connecting the safety ground wire

NOTE: For equipment using –(48–60) V DC power supply units (PSUs), a qualified electrician must perform all connections to DC power and to safety grounds. Do not attempt connecting to DC power or installing grounds yourself. All electrical wiring must comply with applicable local or national codes and practices. Damage due to servicing that is not authorized by Dell is not covered by your warranty. Read and follow all safety instructions that came with the product.

1. Strip the insulation from the end of the green or yellow wire, exposing approximately 4.5 mm (0.175 inch) of copper wire.
2. Using a hand-crimping tool (Tyco Electronics, 58433-3 or equivalent), crimp the ring-tongue terminal (Jeerson Terminals Inc., R5-4SA or equivalent) to the green or yellow wire (safety ground wire).
3. Connect the safety ground wire to the grounding post on the back of the system by using a #6-32 nut equipped with a locking washer.

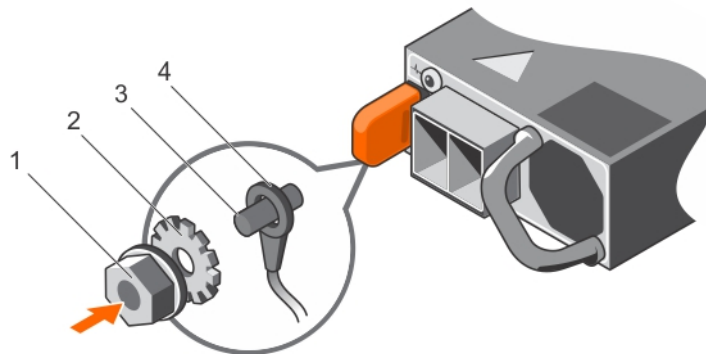

Figure 70. Assembling and connecting the safety ground wire

- | | |
|-------------------|-----------------------|
| 1. #6-32 nut | 2. spring washer |
| 3. grounding post | 4. safety ground wire |

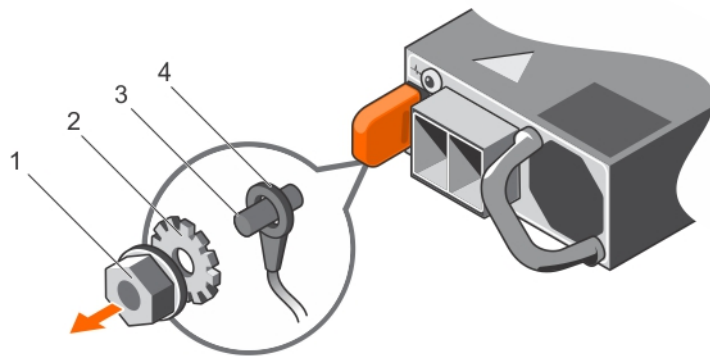

Figure 71. Removing the safety ground wire

- | | |
|-------------------|-----------------------|
| 1. #6-32 nut | 2. spring washer |
| 3. grounding post | 4. safety ground wire |

Assembling the DC input power wires

NOTE: For equipment using $-(48-60)$ V DC power supply units (PSUs), a qualified electrician must perform all connections to DC power and to safety grounds. Do not attempt connecting to DC power or installing grounds yourself. All electrical wiring must comply with applicable local or national codes and practices. Damage due to servicing that is not authorized by Dell is not covered by your warranty. Read and follow all safety instructions that came with the product.

- Strip the insulation from the ends of the DC power wires, exposing approximately 13 mm (0.5 inch) of copper wire.

NOTE: Reversing polarity when connecting DC power wires can permanently damage the power supply or the system.

- Insert the copper ends into the mating connectors and tighten the captive screws at the top of the mating connector by using a Phillips #2 screwdriver.

NOTE: To protect the power supply from electrostatic discharge, the captive screws must be covered with the rubber cap before inserting the mating connector into the power supply.

- Rotate the rubber cap clockwise to fix it over the captive screws.
- Insert the mating connector into the PSU.

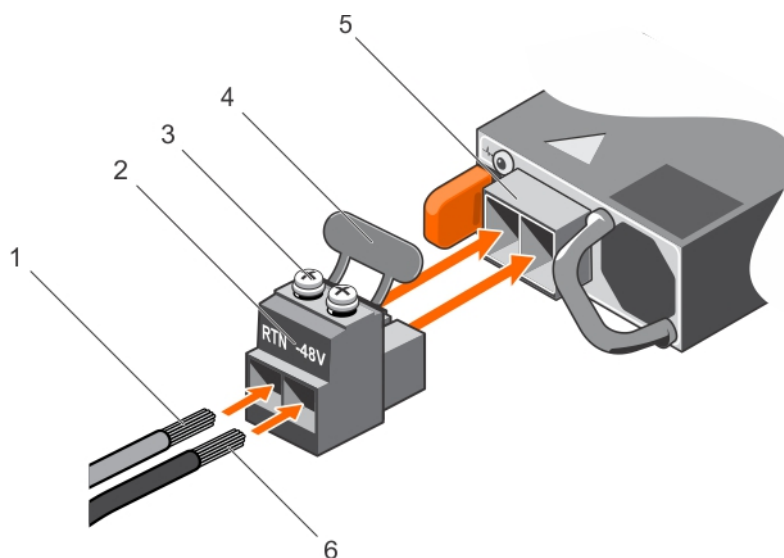

Figure 72. Assembling the DC Input Power Wires

- | | |
|----------------|-----------------------|
| 1. DC wire RTN | 2. DC power connector |
|----------------|-----------------------|

- 3. captive screw (2)
- 5. DC power socket
- 4. rubber cap
- 6. DC wire -48 V

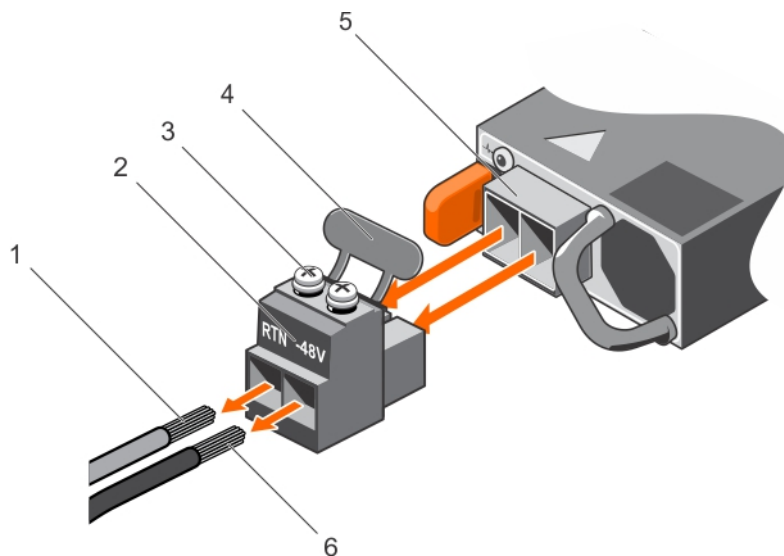

Figure 73. Removing the DC Input Power Wires

- 1. wire RTN
- 2. DC power connector
- 3. captive screw (2)
- 4. rubber cap
- 5. DC power socket
- 6. wire -48 V

Removing a DC power supply unit

NOTE: For equipment using -(48-60) V DC power supply units (PSUs), a qualified electrician must perform all connections to DC power and to safety grounds. Do not attempt connecting to DC power or installing grounds yourself. All electrical wiring must comply with applicable local or national codes and practices. Damage due to servicing that is not authorized by Dell is not covered by your warranty. Read and follow all safety instructions that came with the product.

CAUTION: The system needs one power supply for normal operation. On power-redundant systems, remove and replace only one power supply at a time in a system that is powered on.

NOTE: You may have to unlatch and lift the optional cable management arm if it interferes with power supply removal. For information about the cable management arm, see the rack documentation of your system.

1. Disconnect the power wires from the power source and the connector from the PSU you intend to remove.
2. Disconnect the safety ground wire.
3. Press the release latch and slide the PSU out of the chassis by using the PSU handle.

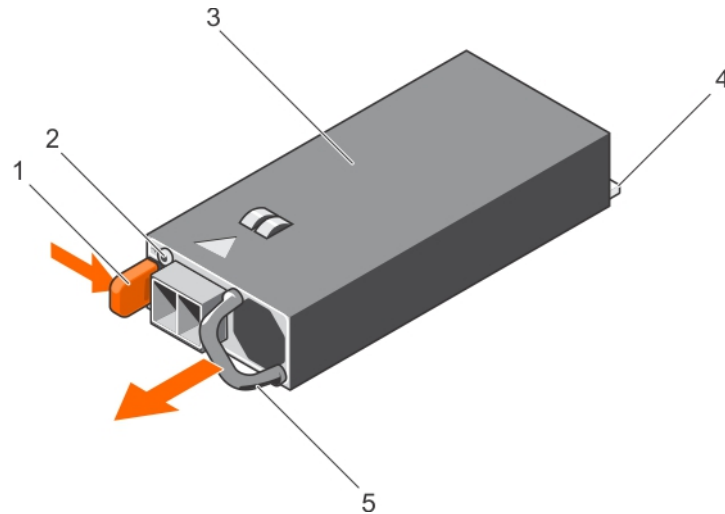

Figure 74. Removing a DC PSU

- | | |
|------------------|----------------------------------|
| 1. release latch | 2. power supply status indicator |
| 3. PSU | 4. power connector |
| 5. PSU handle | |

Related tasks

[Installing a DC power supply unit](#)

Installing a DC power supply unit

NOTE: For equipment using $-(48-60)$ V DC power supply units (PSUs), a qualified electrician must perform all connections to DC power and to safety grounds. Do not attempt connecting to DC power or installing grounds yourself. All electrical wiring must comply with applicable local or national codes and practices. Damage due to servicing that is not authorized by Dell is not covered by your warranty. Read and follow all safety instructions that came with the product.

1. Follow the safety guidelines listed in the Safety instructions section.
2. Follow the procedure listed in the Before working inside your system section.
3. If installed, remove the PSU blank.
4. Verify that both the PSUs are of the same type and have the same maximum output power.

NOTE: The maximum output power (shown in watts) is listed on the PSU label.

1. Slide the PSU into the chassis until the PSU is fully seated and the release latch snaps into place.

NOTE: If you have unlatched the cable management arm, relatch it. For information about the cable management arm, see the rack documentation.

2. Connect the safety ground wire.
3. Install the DC power connector in the PSU.

CAUTION: When connecting the power wires, ensure that you secure the wires with the strap to the PSU handle.

4. Connect the wires to a DC power source.

NOTE: When installing, hot-swapping, or hot-adding a new PSU, wait for 15 seconds for the system to recognize the PSU and determine its status. The PSU status indicator turns green to signify that the PSU is functioning properly.

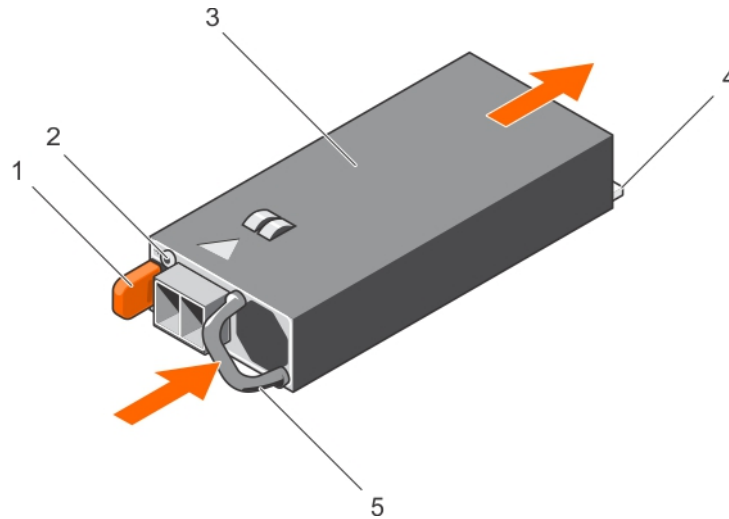

Figure 75. Installing a DC PSU

- | | |
|------------------|----------------------------------|
| 1. release latch | 2. power supply status indicator |
| 3. PSU | 4. power connector |
| 5. PSU handle | |

- Follow the procedure listed in the After working inside your system section.

Related references

[Safety instructions](#)

Related tasks

[Before working inside your system](#)

[Removing the power supply unit blank](#)

[Removing a DC power supply unit](#)

System battery

The system battery is used to power the real-time clock and storing the BIOS settings of the system.

Replacing the system battery

NOTE: There is a danger of a new battery exploding if it is incorrectly installed. Replace the battery only with the same or equivalent type recommended by the manufacturer. For more information, see the safety information that shipped with your system.

CAUTION: Many repairs may only be done by a certified service technician. You should only perform troubleshooting and simple repairs as authorized in your product documentation, or as directed by the online or telephone service and support team. Damage due to servicing that is not authorized by Dell is not covered by your warranty. Read and follow the safety instructions that are shipped with your product.

1. Follow the safety guidelines listed in the Safety instructions section.
2. Follow the procedure listed in the Before working inside your system section.
3. Remove the cooling shroud.
1. Locate the battery socket. For more information, see the Jumpers and connectors section.

CAUTION: To avoid damage to the battery connector, you must firmly support the connector while installing or removing a battery.

2. Place your finger between the securing tabs at the negative side of the battery connector, and lift the battery out of the socket.

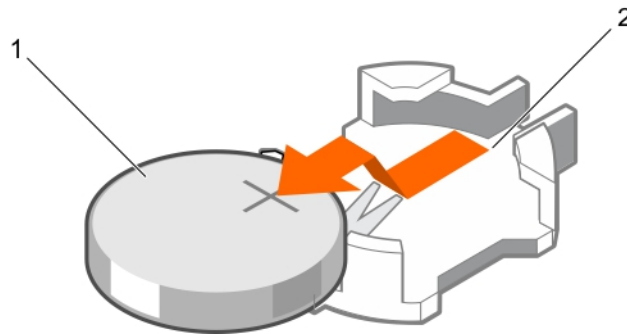

Figure 76. Removing the system battery

- a. system battery
 - b. system battery slot
3. To install a new system battery, hold the battery with the "+" facing up and slide it under the securing tabs.
 4. Press the battery into the connector until it snaps into place.

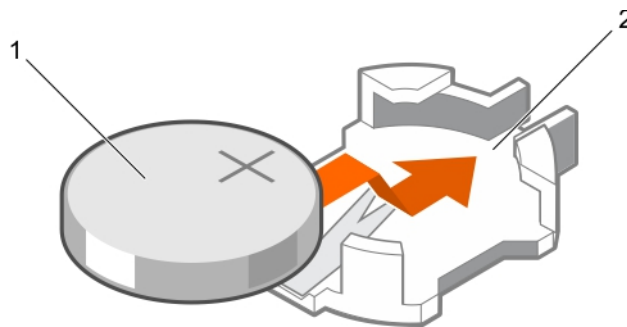

Figure 77. Installing the system battery

- a. system battery
 - b. system battery slot
1. Install the cooling shroud.
 2. Follow the procedure listed in the After working inside your system section.
 3. While booting, press F2 to enter System Setup and ensure the battery is operating properly.
 4. Enter the correct time and date in the System Setup **Time** and **Date** fields.
 5. Exit System Setup.

Related references

[Safety instructions](#)

[System board jumpers and connectors](#)

Related tasks

[Before working inside your system](#)

[Removing the cooling shroud](#)

[Installing the cooling shroud](#)

[After working inside your system](#)

Hard drive backplane

Depending on the configuration, your system supports one of the following:

Eight hard drive system supports	2.5-inch (x4) SAS/SATA backplane
10 hard drive system supports	2.5-inch (x10) SAS/SATA backplane that supports X10 and 4 (PCIe SSDs)
24 hard drive system supports	1.8-inch (x24) SAS/SATA backplane

Depending on the configuration, your system supports 2.5-inch ten hard drive SAS/SATA backplane that supports X10 and 4 (PCIe SSDs).

Removing the hard drive backplane

CAUTION: Many repairs may only be done by a certified service technician. You should only perform troubleshooting and simple repairs as authorized in your product documentation, or as directed by the online or telephone service and support team. Damage due to servicing that is not authorized by Dell is not covered by your warranty. Read and follow the safety instructions that are shipped with your product.

CAUTION: To prevent damage to the hard drives and hard drive backplane, remove the hard drives from the system before removing the hard drive backplane.

CAUTION: Note the number of each hard drive and temporarily label them before removal so that you can replace them in the same locations.

1. Follow the safety guidelines listed in the Safety instructions section.
2. Follow the procedure listed in the Before working inside your system section.
3. Remove all hard drives.
 1. Disconnect the SAS/SATA/SSD data cables and power cable from the backplane.
 2. If applicable, disconnect the power and data cable from the optical drive.
 3. Push the backplane blue release tabs in the direction of the arrows and lift the backplane upwards.
 4. Pull the backplane away from the system until the securing slots on the backplane are free from the tabs on the chassis.

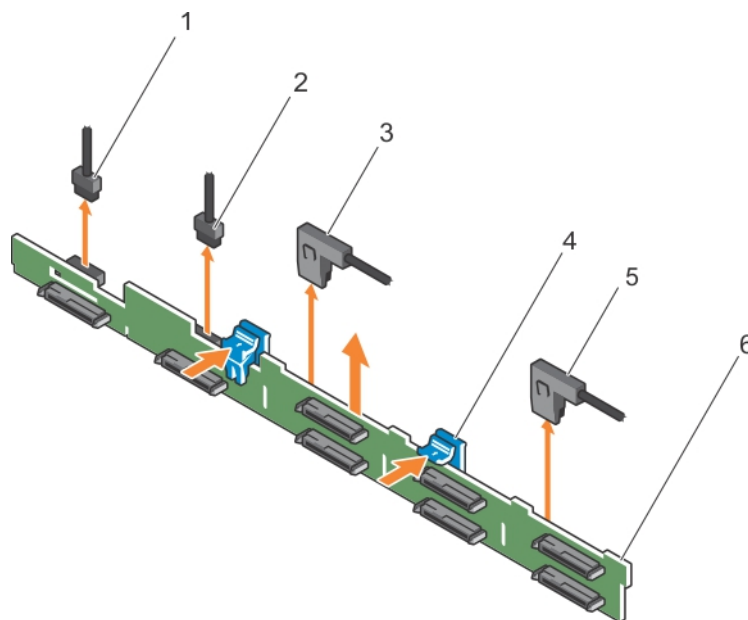

Figure 78. Removing the 2.5-inch (x8) hard drive backplane

- | | |
|---------------------------|---------------------------|
| 1. backplane signal cable | 2. backplane signal cable |
| 3. SAS A cable | 4. release tabs (2) |
| 5. SAS B cable | 6. backplane |

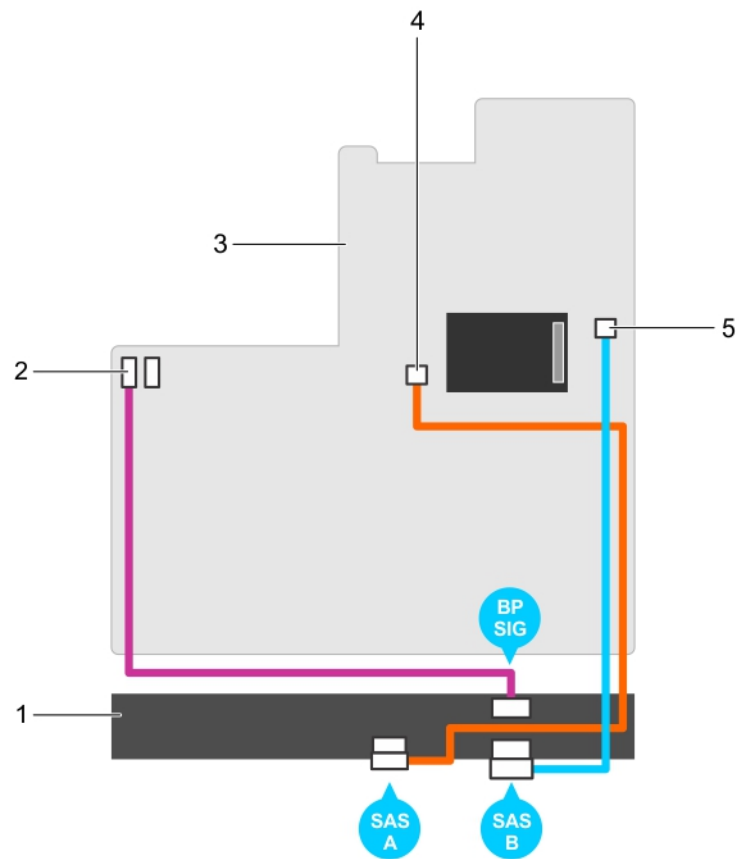

Figure 79. Cabling diagram—2.5-inch (x8) hard drive systems

- | | |
|------------------------------------|-------------------------------------|
| 1. SAS backplane | 2. signal connector on system board |
| 3. system board | 4. SAS A connector on system board |
| 5. SAS B connector on system board | |

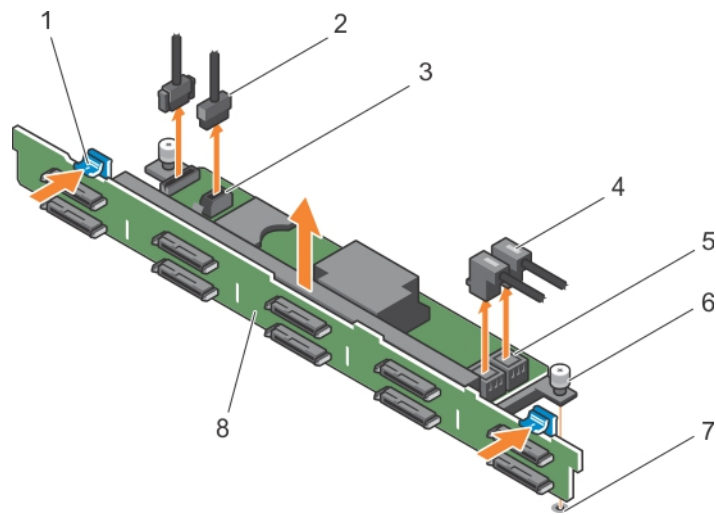

Figure 80. Removing the 2.5-inch (x10) hard drive backplane

- | | |
|------------------------------|--------------------|
| 1. release tab | 2. SD signal cable |
| 3. SD signal cable connector | 4. SAS cables (2) |
| 5. SAS cable connector (2) | 6. guide pin |
| 7. guide pin slot | 8. backplane |

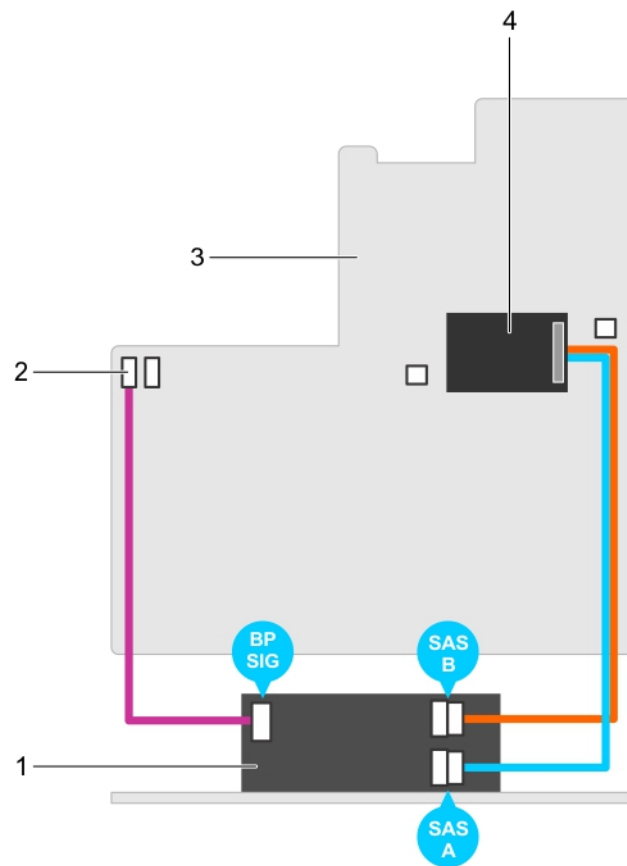

Figure 81. Cabling diagram—2.5-inch (x10) hard drive systems

- 1. SAS backplane expander card
- 2. signal cable connector on the system board
- 3. system board
- 4. integrated storage controller card

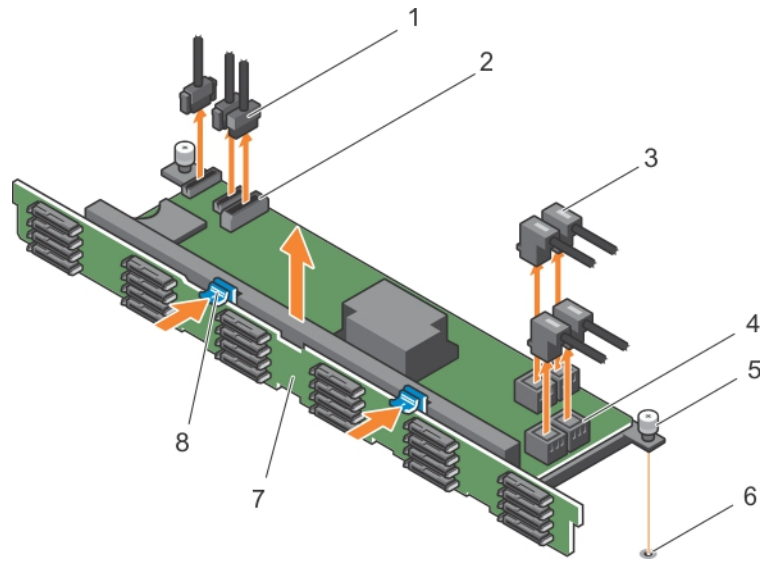

Figure 82. Removing the 1.8-inch (x24) hard drive backplane

- | | |
|------------------------|----------------------------------|
| 1. SD signal cable (3) | 2. SD signal cable connector (2) |
| 3. SAS cables (4) | 4. SAS cable connector (4) |
| 5. guide pin | 6. guide pin slot |
| 7. backplane | 8. release tab (2) |

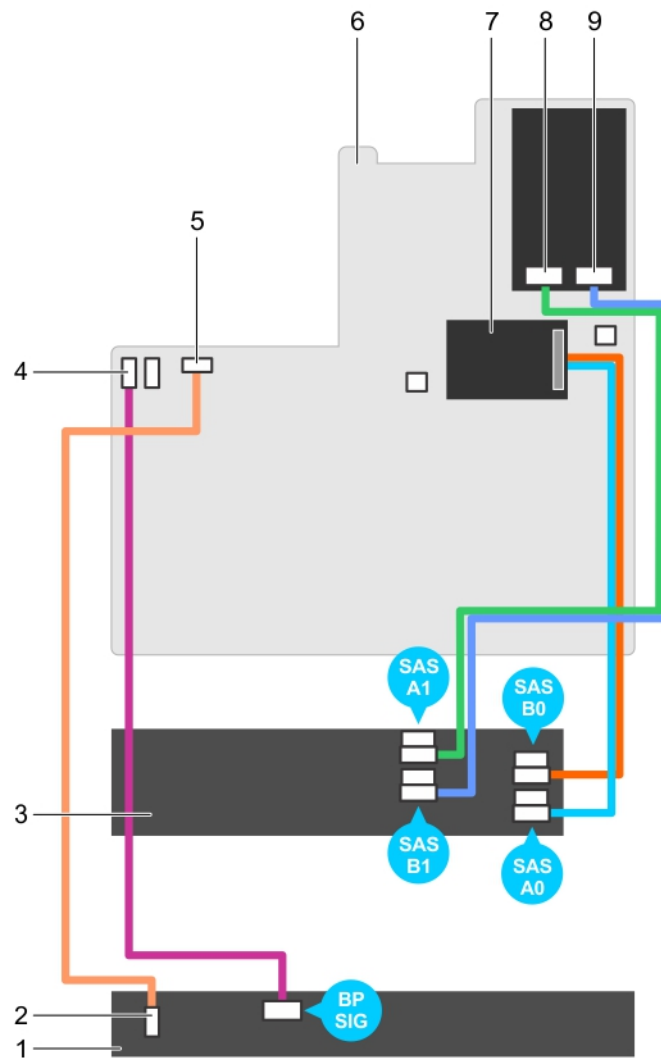

Figure 83. Cabling diagram—1.8-inch (x24) hard drive systems

- | | |
|---------------------------------------|----------------------------------|
| 1. SAS backplane | 2. SD signal cable connector |
| 3. SAS backplane expander card | 4. SD signal cable connector |
| 5. SD signal cable connector | 6. system board |
| 7. integrated storage controller card | 8. SAS connector on system board |
| 9. SAS connector on system board | |

Related references

[Safety instructions](#)

Related tasks

[Before working inside your system](#)

[Installing the hard drive backplane](#)

Installing the hard drive backplane

CAUTION: Many repairs may only be done by a certified service technician. You should only perform troubleshooting and simple repairs as authorized in your product documentation, or as directed by the online or telephone service and support team. Damage due to servicing that is not authorized by Dell is not covered by your warranty. Read and follow the safety instructions that are shipped with your product.

1. Follow the safety guidelines listed in the Safety instructions section.
2. Follow the procedure listed in the Before working inside your system section.
1. Use the hooks on the chassis as guides to align the hard drive backplane.
2. Lower the hard drive backplane until the release tabs snap into place.
3. Connect the SAS/SATA/SSD data, signal, and power cables to the backplane.

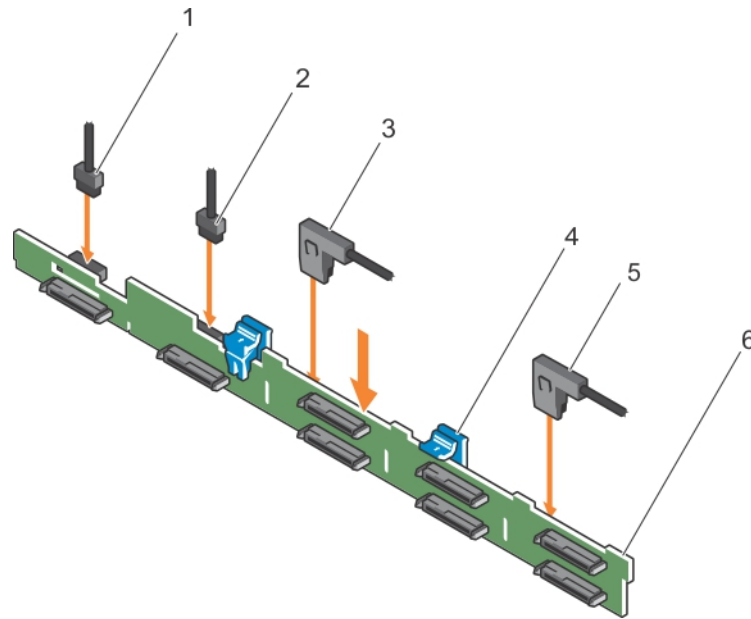

Figure 84. Installing the 2.5-inch (x8) hard drive backplane

- | | |
|---------------------------|---------------------------|
| 1. backplane signal cable | 2. backplane signal cable |
| 3. SAS A cable | 4. release tabs (2) |
| 5. SAS B cable | 6. backplane |

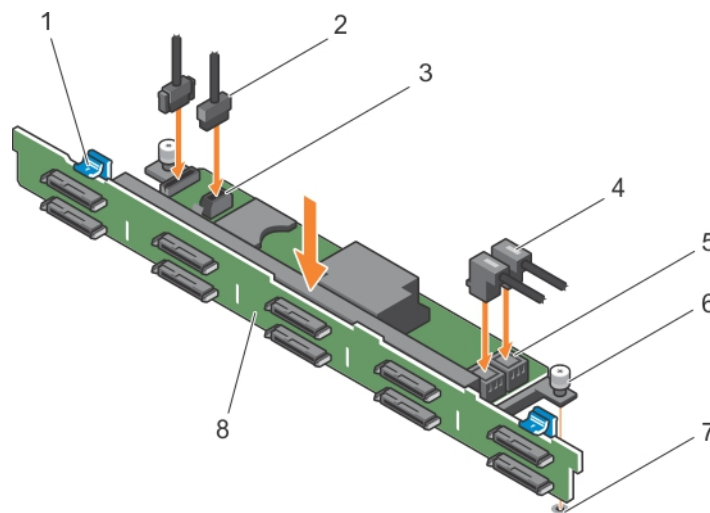

Figure 85. Installing the 2.5-inch (x10) hard drive backplane

- | | |
|------------------------------|--------------------|
| 1. release tab | 2. SD signal cable |
| 3. SD signal cable connector | 4. SAS cables (2) |

- 5. SAS cable connector (2)
- 6. guide pin
- 7. guide pin slot
- 8. backplane

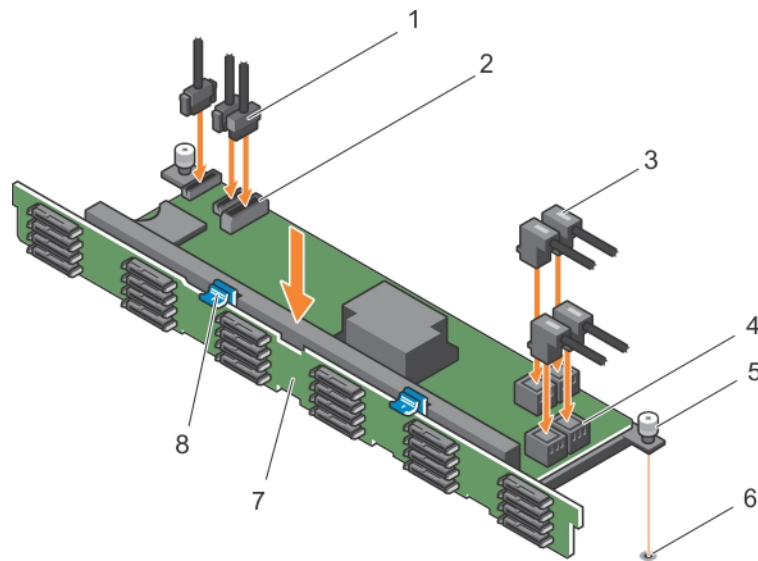

Figure 86. Installing the 1.8-inch (x24) hard drive backplane

- 1. SD signal cable (3)
- 2. SD signal cable connector (2)
- 3. SAS cables (4)
- 4. SAS cable connector (4)
- 5. guide pin
- 6. guide pin slot
- 7. backplane
- 8. release tab (2)

1. Install the hard drives in their original locations.
2. Follow the procedure listed in the After working inside your system section.

Related references

- [Safety instructions](#)
- [Getting help](#)
- [Using system diagnostics](#)

Related tasks

- [Before working inside your system](#)
- [After working inside your system](#)
- [Removing the hard drive backplane](#)

Control panel assembly

Removing the control panel board—eight hard drive system

CAUTION: Many repairs may only be done by a certified service technician. You should only perform troubleshooting and simple repairs as authorized in your product documentation, or as directed by the online or telephone service and support team. Damage due to servicing that is not authorized by Dell is not covered by your warranty. Read and follow the safety instructions that are shipped with your product.

CAUTION: The display module connector is a ZIF (zero insertion force) connector. Ensure that the locking tab on the connector is released before removal and insertion. The locking tab must be engaged after insertion.

1. Follow the safety guidelines listed in the Safety instructions section.

2. Follow the procedure listed in the Before working inside your system section.
3. Keep the Philips #2 screwdriver ready.
1. Disconnect the control panel and display module cables from the control panel board.
2. Remove the two screws that secure the control panel board to the chassis.
3. Slide the control panel board toward the back and out of the system.

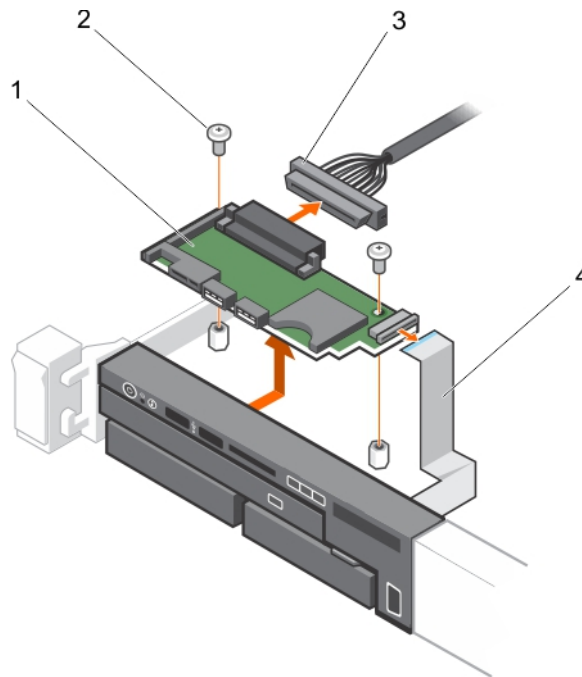

Figure 87. Removing the control panel board

- | | |
|------------------------|-------------------------|
| 1. control panel board | 2. screws (2) |
| 3. control panel cable | 4. display module cable |

Related references

[Safety instructions](#)

Related tasks

[Before working inside your system](#)

[Installing the control panel board—eight hard drive system](#)

Installing the control panel board—eight hard drive system

CAUTION: Many repairs may only be done by a certified service technician. You should only perform troubleshooting and simple repairs as authorized in your product documentation, or as directed by the online or telephone service and support team. Damage due to servicing that is not authorized by Dell is not covered by your warranty. Read and follow the safety instructions that are shipped with your product.

1. Follow the safety guidelines listed in the Safety instructions section.
2. Keep the Philips #2 screwdriver ready.
1. Align the screw holes on the control panel board with the standoffs on the chassis.
2. Replace the two screws that secure the control panel board to the chassis.

CAUTION: The display module connector is a ZIF (zero insertion force) connector. Ensure that the locking tab on the connector is released before removal and insertion. The locking tab must be engaged after insertion.

3. Connect control panel and display module cables to the control panel board.

4. If required, route the power and data cables along the chassis wall.

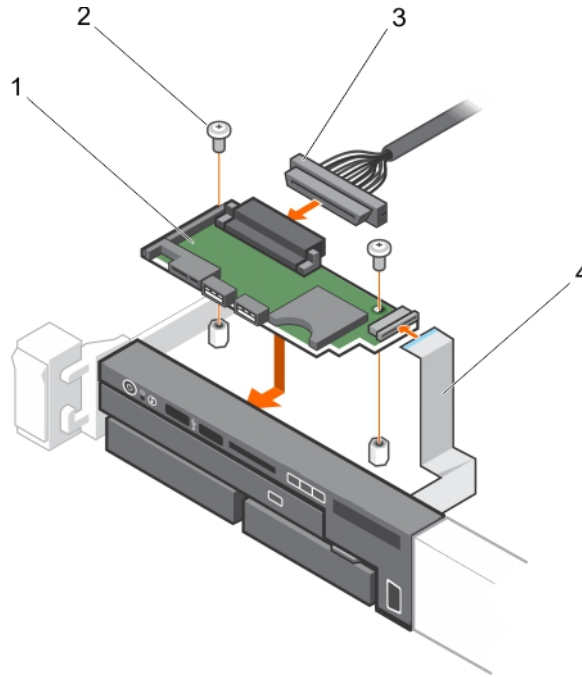

Figure 88. Installing the control panel board

- | | |
|------------------------|-------------------------|
| 1. control panel board | 2. screws (2) |
| 3. control panel cable | 4. display module cable |

Follow the procedure listed in the After working inside your system section.

Related references

[Safety instructions](#)

Related tasks

[After working inside your system](#)

[Removing the control panel board—eight hard drive system](#)

Removing the control panel—eight hard drive system

CAUTION: Many repairs may only be done by a certified service technician. You should only perform troubleshooting and simple repairs as authorized in your product documentation, or as directed by the online or telephone service and support team. Damage due to servicing that is not authorized by Dell is not covered by your warranty. Read and follow the safety instructions that are shipped with your product.

CAUTION: The display module connector is a ZIF (zero insertion force) connector. Ensure that the locking tab on the connector is released before removal and insertion. The locking tab must be engaged after insertion.

1. Follow the safety guidelines listed in the Safety instructions section.
2. Follow the procedure listed in the Before working inside your system section.
3. Keep the Philips #1 screwdriver ready.
1. Disconnect the display module cable from the control panel board.
2. Remove the screw (located at the top of the chassis) that secures the control panel to the chassis.

CAUTION: Applying excessive force while pulling upward may damage the control panel.

NOTE: Apart from the screw, the control panel has three tabs (one on the left and two tabs on top) that secure it to the chassis.

3. Hold the top edge of the control panel at the corners and pull upward until the control panel tabs are released.
4. Hold the right edge of the control panel and rotate it toward the left until it is released from the chassis.
5. Pull the control panel away from the chassis.

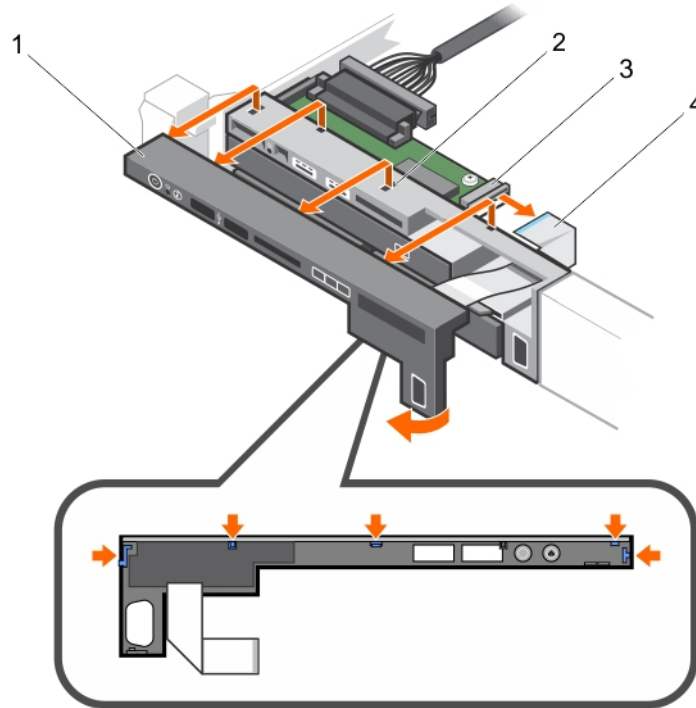

Figure 89. Removing the control panel for eight hard drive system

- | | |
|---------------------------------|------------------------------------|
| 1. control panel | 2. notch on chassis front wall (2) |
| 3. display module ZIF connector | 4. display module cable |

Related references

[Safety instructions](#)

Related tasks

[Before working inside your system](#)

[Installing the control panel—eight hard drive system](#)

Installing the control panel—eight hard drive system

CAUTION: Many repairs may only be done by a certified service technician. You should only perform troubleshooting and simple repairs as authorized in your product documentation, or as directed by the online or telephone service and support team. Damage due to servicing that is not authorized by Dell is not covered by your warranty. Read and follow the safety instructions that are shipped with your product.

1. Follow the safety guidelines listed in the Safety instructions section.
2. Keep the Philips #1 screwdriver ready.
1. Slide the left side of the control panel into the chassis so that the left tab on the control panel aligns with the slot on the chassis wall and the top left tab aligns with the slot on the top of the chassis.
2. Pull the display module cable through the opening and into the chassis.
3. Push the right side of the control panel until the top right tab aligns with the top of the chassis and the panel snaps into place.

- Using a Philips #1 screwdriver, replace the screw (located at the bottom of the chassis) that secures the control module to the chassis.

CAUTION: The display module connector is a ZIF (zero insertion force) connector. Ensure that the locking tab on the connector is released before removal and insertion. The locking tab must be engaged after insertion.

- Connect the display module cable to the control panel board.

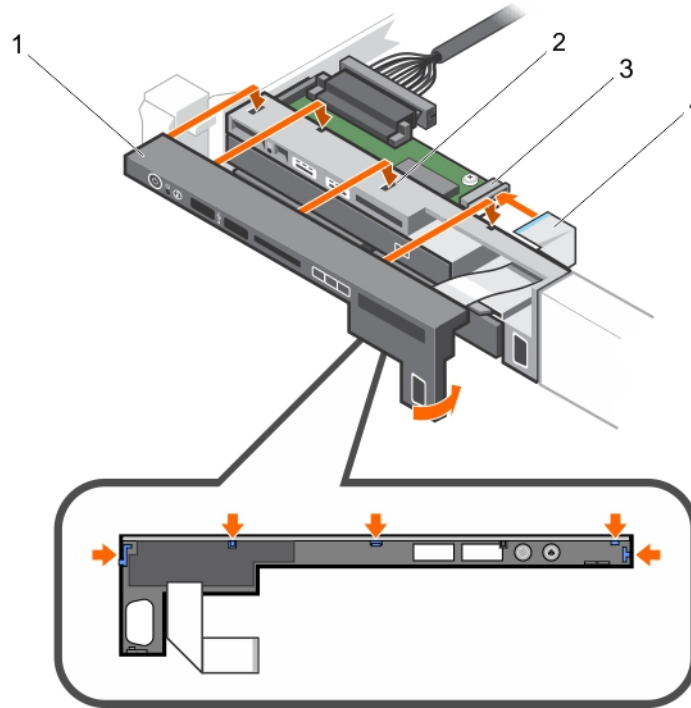

Figure 90. Installing the control panel for eight hard drive system

- | | |
|---------------------------------|------------------------------------|
| 1. control panel | 2. notch on chassis front wall (2) |
| 3. display module ZIF connector | 4. display module cable |

Follow the procedure listed in the After working inside your system section.

Related tasks

[After working inside your system](#)

[Removing the control panel—eight hard drive system](#)

Removing the control panel—10 hard drive and 24 hard drive system

CAUTION: Many repairs may only be done by a certified service technician. You should only perform troubleshooting and simple repairs as authorized in your product documentation, or as directed by the online or telephone service and support team. Damage due to servicing that is not authorized by Dell is not covered by your warranty. Read and follow the safety instructions that are shipped with your product.

- Follow the safety guidelines listed in the Safety instructions section.
- Follow the procedure listed in the Before working inside your system section.
- Keep the Philips #1 screwdriver ready.
 - Remove the screw (located at the top of the chassis) that secures the control panel to the chassis.
 - Remove the control panel cable from the connectors on the system board (J_CP and J_FP_USB) and the hard drive expander card.

NOTE: To locate the connectors on the system board, see the System board connectors section.

3. Slide the control panel out of the chassis.
4. Disconnect the control panel cable from the control panel.

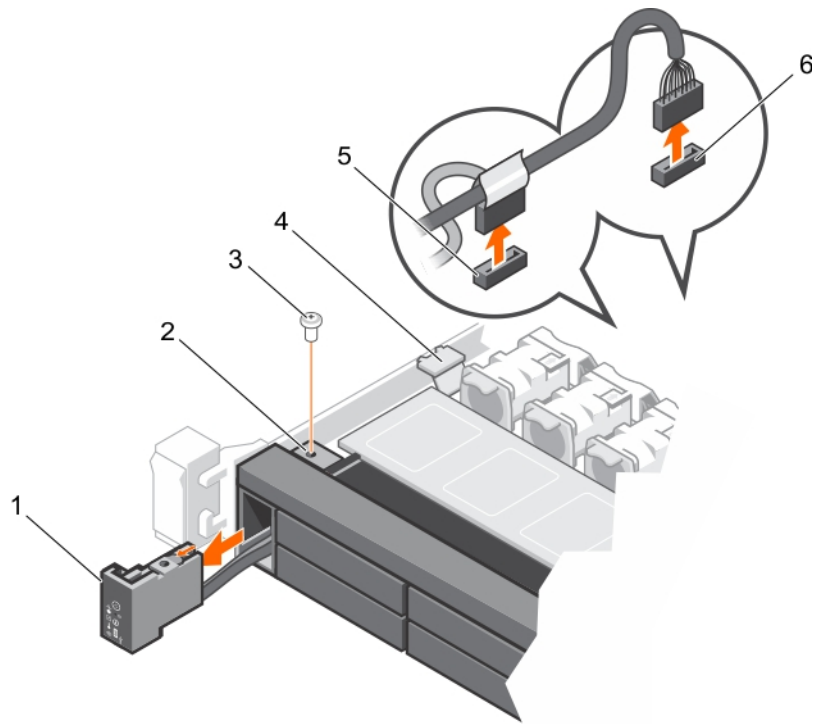

Figure 91. Removing the control panel for 10 and 24 hard drive system

- | | |
|---------------------------------------|---|
| 1. control panel | 2. screw hole |
| 3. screw | 4. cable securing clip |
| 5. J_CP connector on the system board | 6. J_FP_USB connector on the system board |

Related references

[Safety instructions](#)
[System board jumpers and connectors](#)

Related tasks

[Before working inside your system](#)
[Installing the control panel–10 hard drive system and 24 hard drive system](#)

Installing the control panel–10 hard drive system and 24 hard drive system

CAUTION: Many repairs may only be done by a certified service technician. You should only perform troubleshooting and simple repairs as authorized in your product documentation, or as directed by the online or telephone service and support team. Damage due to servicing that is not authorized by Dell is not covered by your warranty. Read and follow the safety instructions that are shipped with your product.

1. Follow the safety guidelines listed in the Safety instructions section.
2. Keep the Philips #1 screwdriver ready.
1. Route the control panel cable through the chassis and connect the control panel cable to the control panel.
2. Push the control panel into the chassis till it snaps into place.

NOTE: Ensure that the screw hole on the control panel aligns with the screw hole located at the top of the chassis.

3. Replace the screw that secures the control panel to the chassis.
4. Locate the connectors J_CP and J_FP_USB on the system board.
 - NOTE:** To locate the connectors on the system board, see the Jumpers and connectors section.
5. Connect the control panel cable to the connectors on the system board (J_CP and J_FP_USB) and the hard drive expander card.
 - NOTE:** Ensure that the control panel cable inside the system is routed along the chassis wall and secured by using the cable securing bracket.

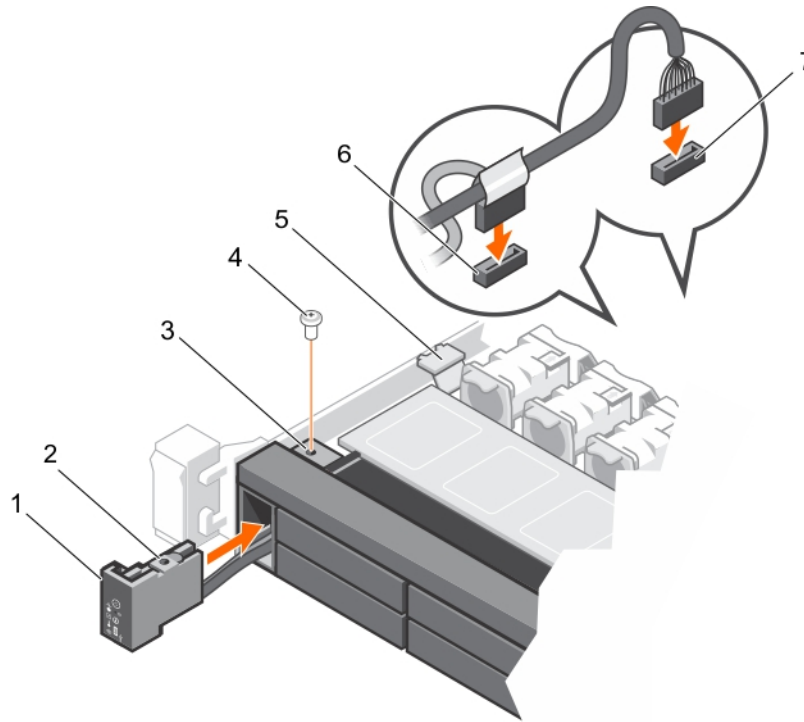

Figure 92. Installing the control panel for 10 and 24 hard drive system

- | | |
|---|---------------------------------------|
| 1. control panel | 2. screw hole on the control panel |
| 3. screw hole on the chassis | 4. screw |
| 5. cable securing clip | 6. J_CP connector on the system board |
| 7. J_FP_USB connector on the system board | |

Follow the procedure listed in the After working inside your system section.

Related references

[Safety instructions](#)

[System board jumpers and connectors](#)

Related tasks

[After working inside your system](#)

[Removing the control panel–10 hard drive and 24 hard drive system](#)

VGA module

NOTE: Only the eight hard drive system has a VGA module on the front panel.

Removing the VGA module

CAUTION: Many repairs may only be done by a certified service technician. You should only perform troubleshooting and simple repairs as authorized in your product documentation, or as directed by the online or telephone service and support team. Damage due to servicing that is not authorized by Dell is not covered by your warranty. Read and follow the safety instructions that are shipped with your product.

CAUTION: The display module connector is a ZIF (zero insertion force) connector. Ensure that the locking tab on the connector is released before removal and insertion. The locking tab must be engaged after insertion.

1. Follow the safety guidelines listed in the Safety instructions section.
2. Follow the procedure listed in the Before working inside your system section.
3. Keep the Philips #2 screwdriver ready.
1. Disconnect the display module cable from the control panel board.
2. Remove the control panel.
3. Disconnect the VGA module cable from the VGA module.
4. Remove the screw that secures the VGA module to the chassis.
5. Slide the VGA module out of the chassis.

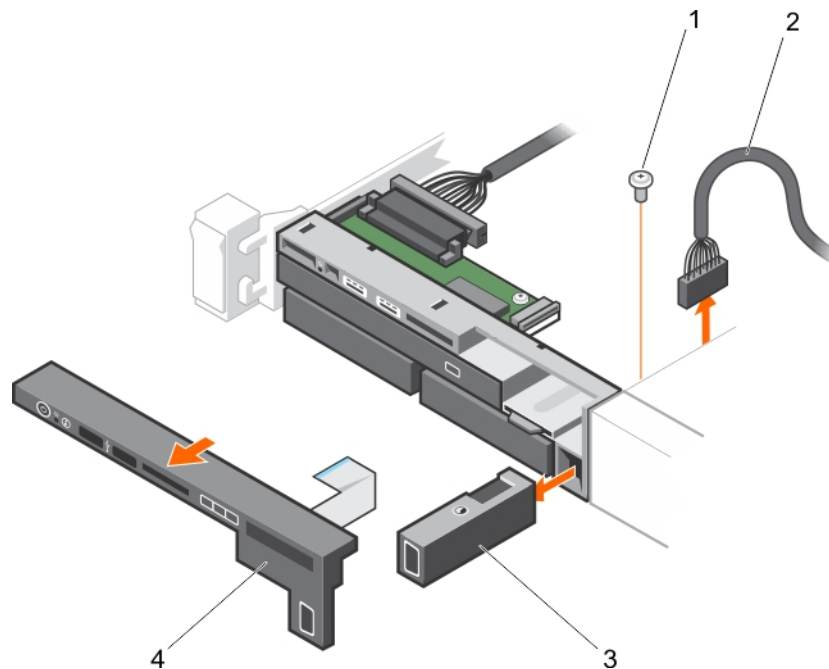

Figure 93. Removing the VGA Module

- | | |
|---------------|---------------------|
| 1. screw | 2. VGA module cable |
| 3. VGA module | 4. control panel |

Related references

[Safety instructions](#)

Related tasks

[Before working inside your system](#)

[Removing the control panel—10 hard drive and 24 hard drive system](#)

[Removing the control panel—eight hard drive system](#)

[Installing the VGA module](#)

Installing the VGA module

CAUTION: Many repairs may only be done by a certified service technician. You should only perform troubleshooting and simple repairs as authorized in your product documentation, or as directed by the online or telephone service and support team. Damage due to servicing that is not authorized by Dell is not covered by your warranty. Read and follow the safety instructions that are shipped with your product.

NOTE: This procedure applies only to the eight hard drive system.

1. Follow the safety guidelines listed in the Safety instructions section.
2. Keep the Philips #2 screwdriver ready.
1. Push the VGA module into the chassis and align the threaded screw hole on the VGA module with the screw hole on the chassis.
2. Replace the screw (at the bottom of the chassis) that secures the VGA module to the chassis.
3. Replace the control panel.
4. Connect the VGA module cable to the VGA module.

CAUTION: The display module connector is a ZIF (zero insertion force) connector. Ensure that the locking tab on the connector is released before removal and insertion. The locking tab must be engaged after insertion.

5. Connect the display module cables to the control panel board.

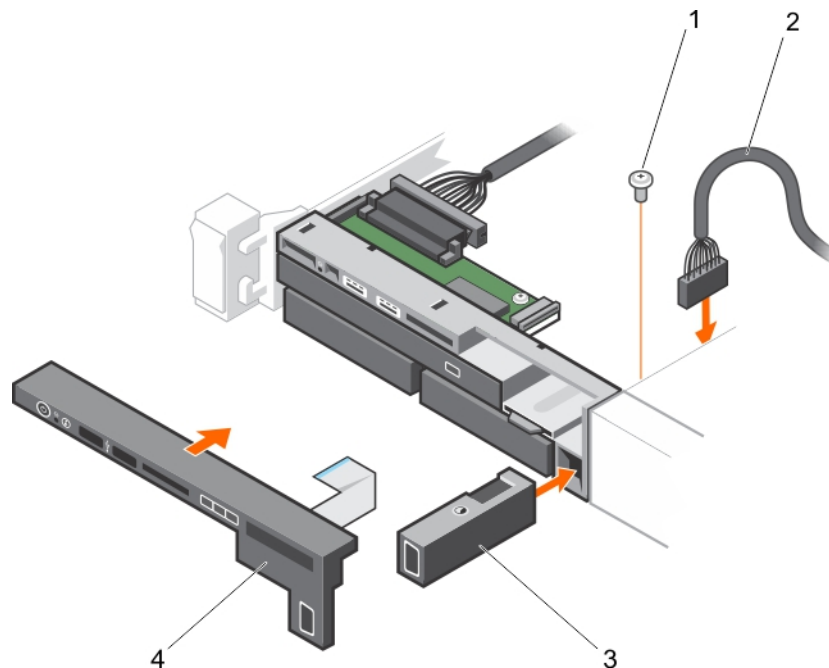

Figure 94. Installing the VGA module

- | | |
|---------------|---------------------|
| 1. screw | 2. VGA module cable |
| 3. VGA module | 4. control panel |

Follow the procedure listed in the After working inside your system section.

Related references

[Safety instructions](#)

Related tasks

[Installing the control panel—10 hard drive system and 24 hard drive system](#)

[Installing the control panel—eight hard drive system](#)

System board

A system board (also known as the motherboard) is the main printed circuit board in the system with different connectors used to connect different components or peripherals of the system. A system board provides the electrical connections to the components in the system to communicate.

Removing the system board

CAUTION: Many repairs may only be done by a certified service technician. You should only perform troubleshooting and simple repairs as authorized in your product documentation, or as directed by the online or telephone service and support team. Damage due to servicing that is not authorized by Dell is not covered by your warranty. Read and follow the safety instructions that are shipped with your product.

CAUTION: If you are using the Trusted Platform Module (TPM) with an encryption key, you may be prompted to create a recovery key during program or System Setup. Be sure to create and safely store this recovery key. If you replace this system board, supply the recovery key when you restart your system or program before you can access the encrypted data on your hard drives.

CAUTION: Do not attempt to remove the TPM plug-in module from the system board. After the TPM plug-in module is installed, it is cryptographically bound to that specific system board. Any attempt to remove an installed TPM plug-in module breaks the cryptographic binding, and it cannot be re-installed or installed on another system board.

1. Follow the safety guidelines listed in the Safety instructions section.
2. Follow the procedure listed in the Before working inside your system section.
3. Remove the following:

- a. Cooling shroud
- b. Memory modules
- c. Cooling fans
- d. Power supply units
- e. All expansion card risers and expansion cards

NOTE: The heat sink is hot to touch for some time after the system has been powered down. Ensure that you do not touch the heat sinks while removing the system board.

- f. Heat sinks or heat sink blanks and processors or processor blanks

CAUTION: To prevent damage to the processor pins when replacing a faulty system board, ensure that you cover the processor socket with the processor protective cap.

- g. Integrated storage controller card
- h. Network daughter card
- i. Internal dual SD module
- j. Internal USB key (if installed)
- k. Hot-swap hard drives
- l. Hard drive backplane

CAUTION: To avoid damaging the mini SAS cable and connector, follow the correct procedure when removing the mini SAS cable from the system board.

1. Disconnect the mini SAS cable from the system board:
 - a. Push the mini SAS cable connector to slide it further into the connector on the system board.
 - b. Press down and hold the metal tab on the mini SAS cable connector.
 - c. Pull the mini SAS cable out of the connector on the system board.

2. Disconnect all other cables from the system board.

CAUTION: Do not to damage the system identification button while removing the system board from the chassis.

3. Grasp the system board holder, lift the blue release pin, slide the system board toward the front of the system, and lift the system board out of the chassis.

CAUTION: Do not lift the system board by holding a memory module, processor, or other components.

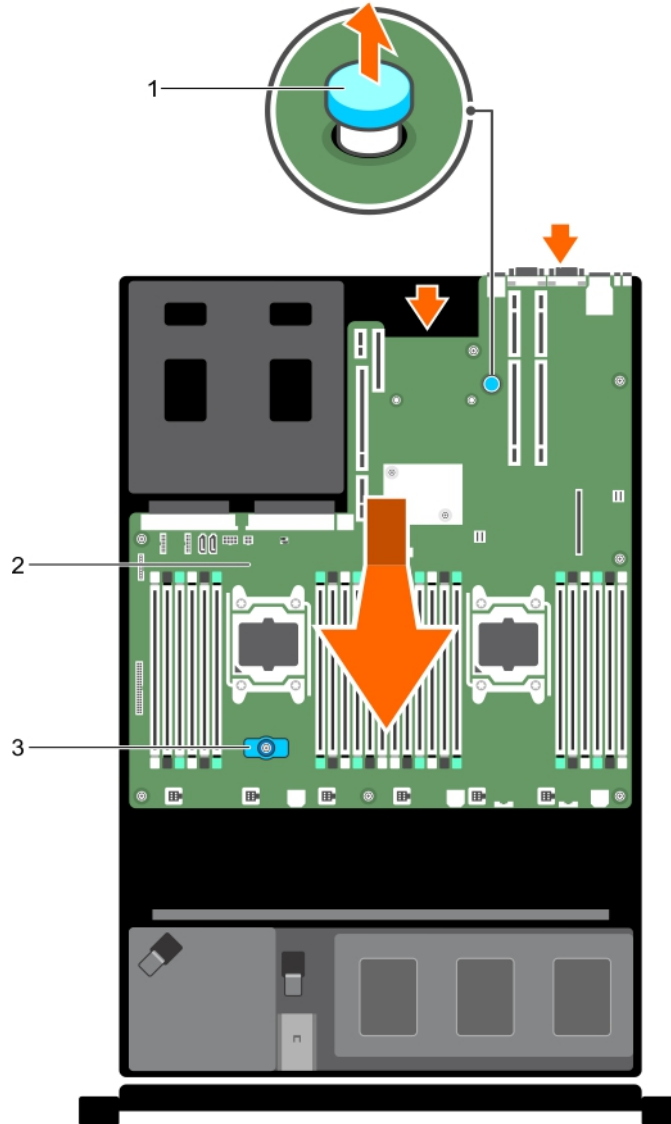

Figure 95. Removing the system board

- a. system board holder
- b. system board
- c. release pin

Related references

[Safety instructions](#)

Related tasks

[Before working inside your system](#)

[Removing the cooling shroud](#)

[Removing memory modules](#)

- Removing a cooling fan
- Removing an AC power supply unit
- Removing a DC power supply unit
- Removing expansion card risers
- Removing an expansion card
- Removing a heat sink
- Removing a processor
- Removing the integrated storage controller card
- Removing the network daughter card
- Removing the optional internal dual SD module
- Replacing the optional internal USB memory key
- Removing a hot swappable hard drive or solid state drive
- Removing the hard drive backplane
- Installing the system board

Installing the system board

 **CAUTION:** Many repairs may only be done by a certified service technician. You should only perform troubleshooting and simple repairs as authorized in your product documentation, or as directed by the online or telephone service and support team. Damage due to servicing that is not authorized by Dell is not covered by your warranty. Read and follow the safety instructions that are shipped with your product.

1. Unpack the new system board assembly.

 **CAUTION:** Do not lift the system board by holding a memory module, processor, or other components.

 **CAUTION:** Do not damage the system identification button while placing the system board into the chassis.

2. Hold the touch points and lower the system board into the chassis.

3. Push the system board toward the back of the chassis until the board is seated correctly.

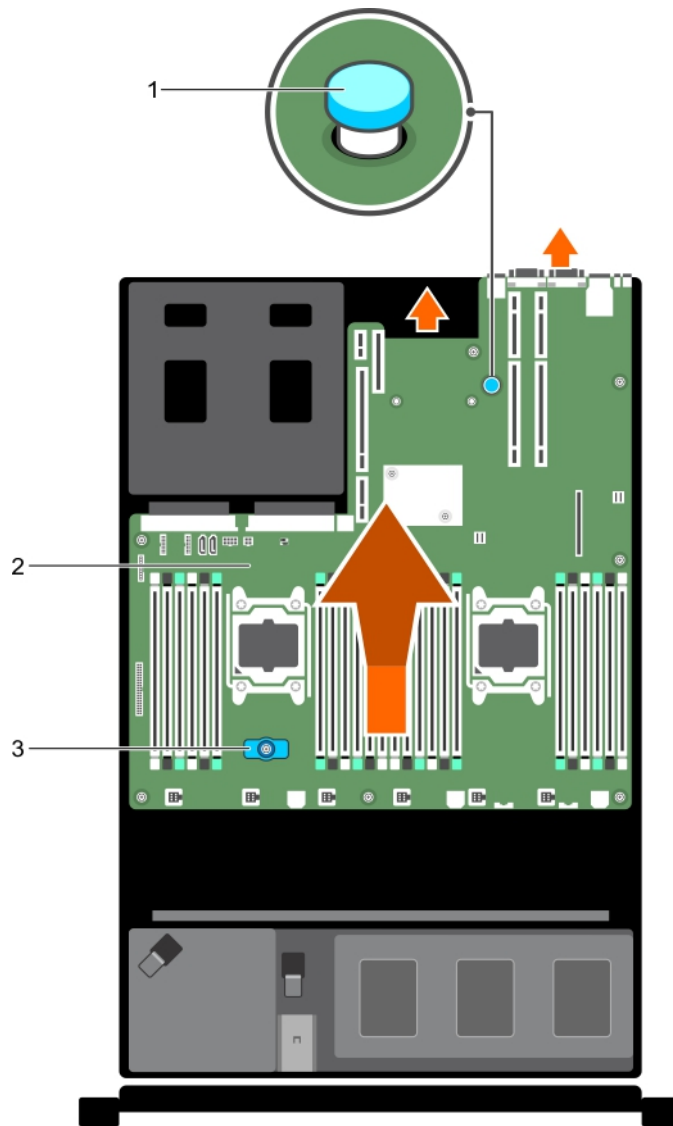

Figure 96. Installing the system board

- a. system board holder
- b. system board
- c. release pin

1. Install the Trusted Platform Module (TPM). For information about how to install TPM, see the Installing the Trusted Platform Module section.
2. Replace the following:
 - a. Cable retention bracket
 - b. PCIe card holder
 - c. Integrated storage controller card
 - d. Internal USB key (if installed)
 - e. Internal dual SD module
 - f. All expansion card risers
 - g. Heat sinks or heat sink blanks and processors or processor blanks
 - h. Memory modules and memory module blanks
 - i. Network daughter card
 - j. Cooling fan assembly
 - k. Cooling shroud
 - l. Power supply units
3. Reconnect all cables to the system board.

i **NOTE:** Ensure that the cables inside the system are routed along the chassis wall and secured by using the cable securing bracket.

4. Follow the procedure listed in the After working inside your system section.
5. Import your new or existing iDRAC Enterprise license. For more information, see the Integrated Dell Remote Access Controller User's Guide at **Dell.com/idracmanuals**.
6. Ensure that you:
 - a. Use the **Easy Restore** feature to restore the Service Tag. For more information, see the Restoring the Service Tag by using the Easy Restore feature section.
 - b. If the Service Tag is not backed up in the backup flash device, enter the system service tag manually. For more information, see the Entering the system service tag section.
 - c. Update the BIOS and iDRAC versions.
 - d. Re-enable the Trusted Platform Module (TPM). For more information, see the Re-enabling the TPM for BitLocker users or Re-enabling the TPM for Intel TXT users section.

Related tasks

- [Replacing the optional internal USB memory key](#)
- [Installing the optional internal dual SD module](#)
- [Installing expansion card risers](#)
- [Installing a processor](#)
- [Installing a heat sink](#)
- [Installing memory modules](#)
- [Installing the network daughter card](#)
- [Installing the cooling shroud](#)
- [Installing an AC power supply unit](#)
- [Installing a DC power supply unit](#)
- [After working inside your system](#)
- [Removing the system board](#)

Entering the system Service Tag by using System Setup

If Easy Restore fails to restore the Service Tag, use System Setup to enter the Service Tag.

1. Turn on the system.
2. Press F2 to enter System Setup.
3. Click **Service Tag Settings**.
4. Enter the Service Tag.

i **NOTE:** You can enter the Service Tag only when the **Service Tag** field is empty. Ensure that you enter the correct Service Tag. After the Service Tag is entered, it cannot be updated or changed.

5. Click **OK**.
6. Import your new or existing iDRAC Enterprise license.
For more information, see the *Integrated Dell Remote Access Controller User's Guide* at www.dell.com/poweredgemanuals.

Restoring the Service Tag by using the Easy Restore feature

By using the Easy Restore feature, you can restore your Service Tag, license, UEFI configuration, and the system configuration data after replacing the system board. All data is automatically backed up in a backup flash device. If BIOS detects a new system board and the Service Tag in the backup flash device, BIOS prompts the user to restore the backup information.

1. Turn on the system.
If BIOS detects a new system board, and if the Service Tag is present in the backup flash device, BIOS displays the Service Tag, the status of the license, and the **UEFI Diagnostics** version.
2. Perform one of the following steps:
 - Press **Y** to restore the Service Tag, license, and diagnostics information.
 - Press **N** to navigate to the Dell Lifecycle Controller based restore options.
 - Press F10 to restore data from a previously created **Hardware Server Profile**.

After the restore process is complete, BIOS prompts to restore the system configuration data.

3. Perform one of the following steps:
 - Press **Y** to restore the system configuration data.
 - Press **N** to use the default configuration settings.After the restore process is complete, the system restarts.

Trusted Platform Module

Trusted Platform Module (TPM) is a dedicated microprocessor designed to secure hardware by integrating cryptographic keys into devices. A software can use a Trusted Platform Module to authenticate hardware devices. As each TPM chip has a unique and secret RSA key burned in as it is produced, it can perform the platform authentication.

CAUTION: Do not attempt to remove the Trusted Platform Module (TPM) from the system board. After the TPM is installed, it is cryptographically bound to that specific system board. Any attempt to remove an installed TPM breaks the cryptographic binding, and it cannot be re-installed or installed on another system board.

NOTE: This is a Field Replaceable Unit (FRU). Removal and installation procedures must be performed only by Dell certified service technicians.

Installing the Trusted Platform Module

CAUTION: Many repairs may only be done by a certified service technician. You should only perform troubleshooting and simple repairs as authorized in your product documentation, or as directed by the online or telephone service and support team. Damage due to servicing that is not authorized by Dell is not covered by your warranty. Read and follow the safety instructions that are shipped with your product.

CAUTION: Do not attempt to remove the Trusted Platform Module (TPM) from the system board. Once the TPM is installed, it is cryptographically bound to that specific system board. Any attempt to remove an installed TPM breaks the cryptographic binding, and it cannot be re-installed or installed on another system board.

1. Follow the safety guidelines listed in the Safety instructions section.
2. Follow the procedure listed in the Before working inside your system section.
1. Locate the TPM connector on the system board.

NOTE: To locate the TPM connector on the system board, see the System board connectors section.

2. Align the edge connectors on the TPM with the slot on the TPM connector.
3. Insert the TPM into the TPM connector such that the plastic rivet aligns with the slot on the system board.
4. Press the plastic rivet until the rivet snaps into place.

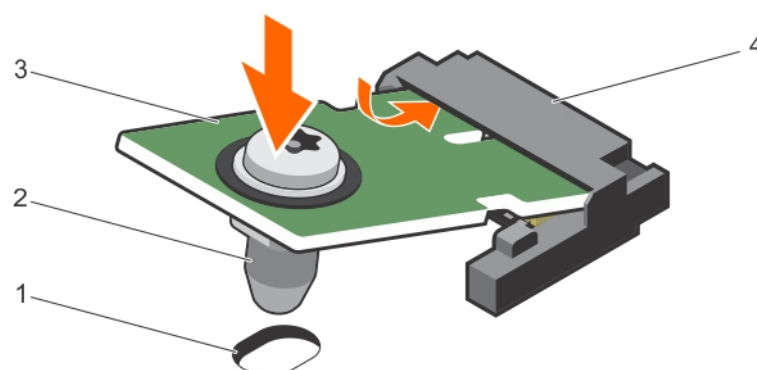

Figure 97. Installing the TPM

1. rivet slot on the system board
2. plastic rivet
3. TPM
4. TPM connector

1. Install the system board.
2. Follow the procedure listed in the After working inside your system section.

Related references

[Safety instructions](#)

[System board jumpers and connectors](#)

Related tasks

[Before working inside your system](#)

[Installing the system board](#)

Initializing the TPM for BitLocker users

Initialize the TPM.

For more information about initializing the TPM, see <https://technet.microsoft.com/en-us/library/cc753140.aspx>.

The **TPM Status** changes to **Enabled, Activated**.

Initializing the TPM for TXT users

1. While booting your system, press F2 to enter System Setup.
2. On the **System Setup Main Menu** screen, click **System BIOS > System Security Settings**.
3. From the **TPM Security** option, select **On with Pre-boot Measurements**.
4. From the **TPM Command** option, select **Activate**.
5. Save the settings.
6. Restart your system.
7. Enter **System Setup** again.
8. On the **System Setup Main Menu** screen, click **System BIOS > System Security Settings**.
9. From the **Intel TXT** option, select **On**.

Technology and Components

The following pages contain information about technology and components.

Topics:

- [iDRAC8](#)
- [Processor](#)
- [Chipset](#)
- [Memory](#)
- [Storage](#)
- [Backplane](#)
- [PERC9](#)
- [Power Supplies](#)
- [Internal Dual SD Module](#)
- [PCIe Risers and Slots](#)
- [Network Daughter Card](#)
- [Video](#)
- [Trusted Platform Module](#)
- [System Board Block Diagram](#)

iDRAC8

iDRAC8 is a systems management hardware and software solution that provides remote management capabilities, crashed system recovery, and power control functions for **Dell™ PowerEdge™** systems.

iDRAC8 features are available based on the purchased license. They are available in the following variants:

- Basic Management with IPMI
- iDRAC8 Express (Rack and Tower servers)
- iDRAC8 Express for Blades
- iDRAC8 Enterprise

The 200-500 series servers will ship with Basic Management as the default, but the customer will have the ability to upgrade to Express or Enterprise by purchasing a digital license key. For the 200-500 series servers, customers who upgrade APOS to Enterprise have the option to purchase the iDRAC Ports Card, which provides the hardware features of a dedicated management NIC and vFlash. The card is not required to activate or enable the rest of the Enterprise features.

i **NOTE:** This is an overview of iDRAC8. For a full technology training on iDRAC8, please refer to the reference material link below.

Internal Link: [iDRAC8](#)

External Link: [iDRAC8](#)

Acquiring Licenses

Use any of the following methods to acquire the licenses:

- E-mail — License is attached to an email that is sent after requesting it from the technical support center.
- Self-Service Portal — A link to the Self-Service Portal is available from iDRAC. Click this link to open the licensing Self-Service Portal on the internet. Currently, you can use the License Self-Service Portal to retrieve licenses that were

purchased with the server. You must contact the sales representative or technical support to buy a new or upgrade license. For more information, see the online help for the self-service portal page.

- Point-of-Sale — License is acquired while placing the order for a system.

New Features

The following list contains the key new features available on iDRAC8:

- iDRAC Direct — Securely connect directly to iDRACWeb UI via USB Cable in front of the server.
- iDRAC Direct (USB) — Offers the convenience of USB keys to install new hardware configurations to Dell 13G servers.
- iDRAC Quick Sync — This feature enables at-the-server management with a Near Field Communication (NFC)-enabled mobile device. Customers may view inventory and monitoring information and configure basic iDRAC settings using a mobile device. This feature is only available on the PowerEdge R630, R730, and R730XD.
- Real-Time Storage Configuration — Configure storage real-time through the iDRACUI.
- Agent-Free SAS Monitoring and PCIe-SSD Monitoring — Monitor 12Gb SAS and PCIe-SSD storage via iDRAC without any OS agents.
- Easy Restore — Automatically restore hardware configuration and license information after a system board replacement.
- Tech Support Report — Gathers all hardware and OS logs and inventory information required for technical support.
- Agent-Free Performance Monitoring — Monitor basic memory, CPU, and I/O performance metrics through iDRAC.

Configurable Temperature and Power Thresholds

- This feature provides capability to modify default warning thresholds for temperature and power consumption warning thresholds from GUI, RACADM, WSMAN, OMSA, and IPMI tool.
- Applicable to both lower and upper warning thresholds for temperature sensors and warning threshold for power consumption reading.

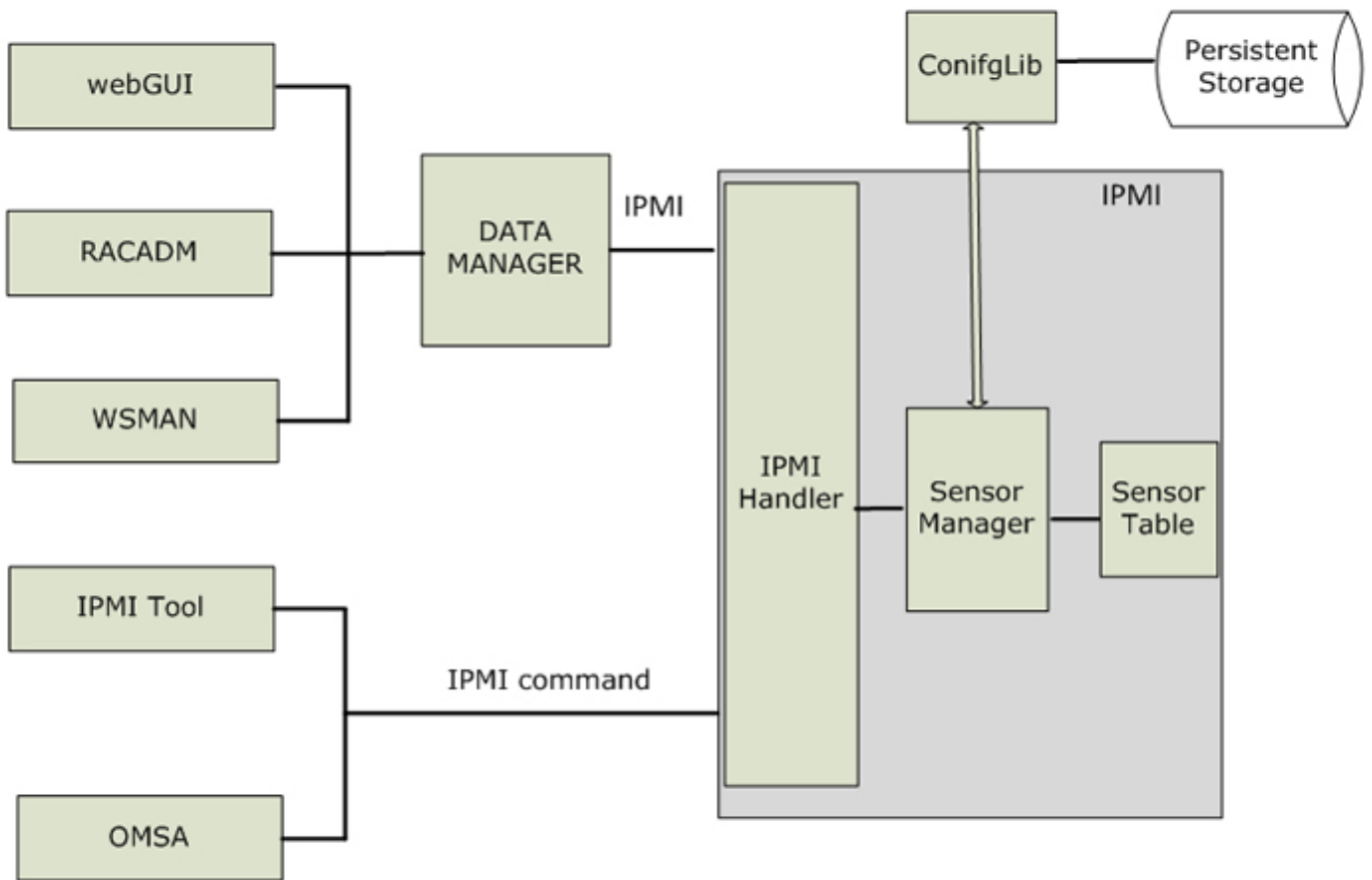

iDRAC Robustness and Self-Healing

- Implemented as a service recovery mechanism, which is responsible for the following tasks:
 - Detects memory leaks in a service and restarts that service.
 - Detects a terminated service and restarts it.
 - Detects a frozen service and restarts it.
 - Detects a service that runs with less number of threads and restarts it.
- The feature is not visible to the user. The user cannot interact with this feature nor change its configuration.

Tech Support Report

- Requires minimal interaction and users can export the report to the management station (local), Common Internet File System (CIFS), or Network File Share (NFS).
- The report is generated in the standard ZIP format. The report contains information that is similar to the information available in the DSET report such as:
 - Hardware inventory for all components.
 - System, Lifecycle Controller, and component attributes.
 - Operating system and application information.
 - Active Lifecycle Controller logs (archived entries are not included).
 - PCIe SSD logs.
 - Storage controller logs.

Processor

The PowerEdge server support the Intel Xeon Processor E5-2600 v3 product family, offering an ideal combination of performance, power efficiency, and cost. These processors provide high performance even in limited floor space, consuming low power, optimal costs, and on workloads ranging from scientific exploration to web-serving and infrastructure applications. In addition to providing raw performance gains, improved I/O is also possible with Intel Integrated I/O, which reduces latency by adding more lanes and doubling the bandwidth.

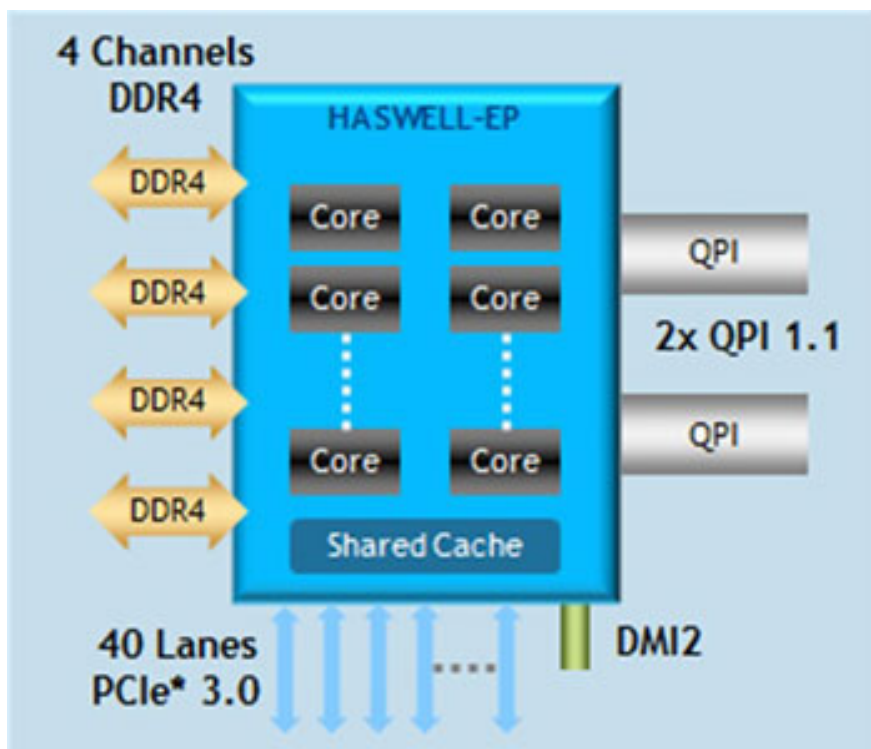

Figure 98. Intel Xeon E2600 v3 product family

Processor Features

The new Intel Xeon processor E5-2600 v3 product family adds new features and improves upon many features of the predecessor Intel Xeon processor E5-2600 v2 series, including:

- Up to 18 execution cores per processor
- Each core supports two threads for up to 36 threads per processor
- 46-bit physical addressing and 48-bit virtual addressing
- 1 GB large-page support
- 32 KB instruction and 32 KB data first-level cache (L1) for each core
- 256 KB shared instruction/data mid-level cache (L2) for each core
- Up to 35 MB last-level cache (LLC) shared among all cores; up to 2.5 MB per core
- Two Intel QuickPath Interconnect (QPI) links up to 9.6 GT/s
- Four Direct Media Interface (DMI) 2 with lanes
- 40 PCIe Gen 3 links capable of 8.0 GT/s
- Socket R, 2011-land FCLGA10 package
- No termination required for non-populated processor (must populate processor socket 1 first)
- Integrated 4-channel DDR4 memory controller

- 64-byte cache line size
- Execute Disable Bit
- Support for processor Turbo Mode
- Increases processor frequency if operating below thermal, power, and current limits
- Streaming SIMD (Single Instruction, Multiple Data) Intel Advanced Vector Extensions (AVX)
- Intel 64 Technology
- Intel VT-x and VT-d technology for virtualization support
- Enhanced Intel SpeedStep technology
- Demand-based switching for active processor power management as well as support for ACPI P-States, C- States, and T-States.

Supported Processors

The **Dell PowerEdge R630** supports up to two processors with up to 22 cores per E5-2600 v4 processor or 18 cores per E5-2600 v3 processor. The table below lists the Intel Xeon E5-2600 v3 processors supported by R630.

Supported Processors							
Processor	Stepping	Clock Speed	Cache	QPI	Cores/ Threads	Turbo	TDP
E5-2699 v3	C1	2.3 GHz	45M	9.6 GT/s	18/36	Turbo	145 W
E5-2698 v3	C1	2.3 GHz	40M	9.6 GT/s	16/32	Turbo	135 W
E5-2697 v3	C1	2.6 GHz	35M	9.6 GT/s	14/28	Turbo	145 W
E5-2695 v3	C1	2.3 GHz	35M	9.6 GT/s	14/28	Turbo	120 W
E5-2690 v3	M1	2.6 GHz	30M	9.6 GT/s	12/24	Turbo	135 W
E5-2683 v3	C1	2.0 GHz	35M	9.6 GT/s	14/28	Turbo	120 W
E5-2680 v3	M1	2.5 GHz	30M	9.6 GT/s	12/24	Turbo	120 W
E5-2670 v3	M1	2.3 GHz	30M	9.6 GT/s	12/24	Turbo	120 W
E5-2660 v3	M1	2.6 GHz	25M	9.6 GT/s	10/20	Turbo	105 W
E5-2650 v3	M1	2.6 GHz	25M	9.6 GT/s	10/20	Turbo	105 W
E5-2640 v3	R2	2.6 GHz	20M	8.0 GT/s	8/16	Turbo	90 W
E5-2630 v3	R2	2.4 GHz	20M	8.0 GT/s	8/16	Turbo	85 W
E5-2620 v3	R2	2.4 GHz	15M	8.0 GT/s	6/12	Turbo	85 W
E5-2609 v3	R2	1.9 GHz	15M	4.0 GT/s	6/6	N/A	85 W
E5-2603 v3	R2	1.6 GHz	15M	4.0 GT/s	6/6	N/A	85 W
E5-2687w v3	R2	3.1 GHz	25M	9.6 GT/s	10/20	Turbo	160 W
E5-2650L v3	M1	1.8 GHz	30M	9.6 GT/s	12/24	Turbo	65 W
E5-2630L v3	R2	1.8 GHz	20M	8.0 GT/s	8/16	Turbo	55 W
E5-2667 v3	R2	3.2 GHz	20M	9.6 GT/s	8/16	Turbo	135 W
E5-2643 v3	R2	3.4 GHz	20M	9.6 GT/s	6/12	Turbo	135 W
E5-2637 v3	R2	3.5 GHz	15M	9.6 GT/s	4/8	Turbo	135 W
E5-2623 v3	R2	3.0 GHz	10M	8.0 GT/s	4/8	Turbo	105 W

The table below lists the Intel Xeon E5-2600 v4 processors supported by R630.

Supported Processors						
Processor	Clock Speed	Cache	QPI	Cores/Threads	Turbo	TDP
E5-2699 v4	2.2 GHz	55M	9.6 GT/s	22/44	Turbo	145 W
E5-2698 v4	2.2 GHz	50M	9.6 GT/s	20/40	Turbo	135 W
E5-2697A v4	2.6 GHz	40M	9.6 GT/s	16/32	Turbo	145 W
E5-2697 v4	2.3 GHz	45M	9.6 GT/s	18/36	Turbo	145 W
E5-2695 v4	2.1 GHz	45M	9.6 GT/s	18/36	Turbo	120 W
E5-2690 v4	2.6 GHz	35M	9.6 GT/s	14/28	Turbo	135 W
E5-2687 v4	3.0 GHz	30M	9.6 GT/s	12/24	Turbo	160 W
E5-2683 v4	2.1 GHz	40M	9.6 GT/s	16/32	Turbo	120 W
E5-2680 v4	2.4 GHz	35M	9.6 GT/s	14/28	Turbo	120 W
E5-2667 v4	3.2 GHz	25M	9.6 GT/s	8/16	Turbo	135 W
E5-2660 v4	2.0 GHz	35M	9.6 GT/s	14/28	Turbo	105 W
E5-2650L v4	1.7 GHz	35M	9.6 GT/s	14/28	Turbo	65 W
E5-2650 v4	2.2 GHz	30M	9.6 GT/s	12/24	Turbo	105 W
E5-2643 v4	3.4 GHz	20M	9.6 GT/s	6/12	Turbo	135 W
E5-2640 v4	2.4 GHz	25M	8.0 GT/s	10/20	Turbo	90 W
E5-2637 v4	3.5 GHz	15M	9.6 GT/s	4/8	Turbo	135 W
E5-2630L v4	1.8 GHz	25M	8.0 GT/s	10/20	Turbo	55 W
E5-2630 v4	2.2 GHz	20M	8.0 GT/s	8/16	Turbo	85 W
E5-2623 v4	2.6 GHz	10M	9.6 GT/s	4/8	Turbo	85 W
E5-2620 v4	2.1 GHz	20M	8.0 GT/s	8/16	Turbo	85 W
E5-2609 v4	1.7 GHz	20M	6.40 GT/s	8/8	No Turbo	85 W
E5-2603 v4	1.7 GHz	15M	6.40 GT/s	6/6	No Turbo	85 W

Chipset

The Intel C610 chipset is implemented on the PowerEdge R730 and R730xd.

The QuickPath Architecture consists of serial point-to-point interconnects for the processors. The PowerEdge R730 and R730xd have a total of two QuickPath Interconnect (QPI) links connecting the processors.

- Each link consists of 20 lanes (full-width) in each direction with a link speed of 9.6 GT/s.
- An additional lane is reserved for a forwarded clock. Data is sent over the QPI links as packets.
- The QuickPath Architecture implemented in E5-2600 v3 features four layers.
- The Physical layer consists of the actual connection between components. It supports Polarity Inversion and Lane Reversal for optimizing component placement and routing.
- The Link layer is responsible for flow control and the reliable transmission of data. The Link layer also provides independent flow control for each message class going to and from the Routing Layer.
- The Routing layer is implemented in a distributed manner between all agents that send Intel QPI messages on the ring (Intel QPI Module, Cbo, IIO, HA). The Intel QPI Module provides a routing function for determining the correct ring stop to forward an inbound packet.
- The Protocol layer is responsible for high-level protocol communications, including the implementation of a MESIF (Modify, Exclusive, Shared, Invalid, and Forward) cache coherence protocol.

Memory

The **Dell PowerEdge R630** supports DDR4 registered DIMMs (RDIMMs), and load-reduced DIMMs (LRDIMMs).

NOTE: MT/s indicates DIMM speed in MegaTransfers per second.

Memory bus operating frequency can be 1866 MT/s, 2133 or 2400 MT/s depending on:

- DIMM type (RDIMM or LRDIMM).
- Number of DIMMs populated per channel.
- System profile selected (for example, Performance Optimized, Custom, or Dense Configuration Optimized).
- Maximum supported DIMM frequency of the processors.

The system contains 24 memory sockets split into two sets of 12 sockets, one set per processor. Each 12-socket set is organized into four channels. In each channel, the release levers of the first socket are marked white, the second socket black, and the third socket green.

NOTE: DIMMs in sockets A1 to A12 are assigned to processor 1 and DIMMs in sockets B1 to B12 are assigned to processor 2.

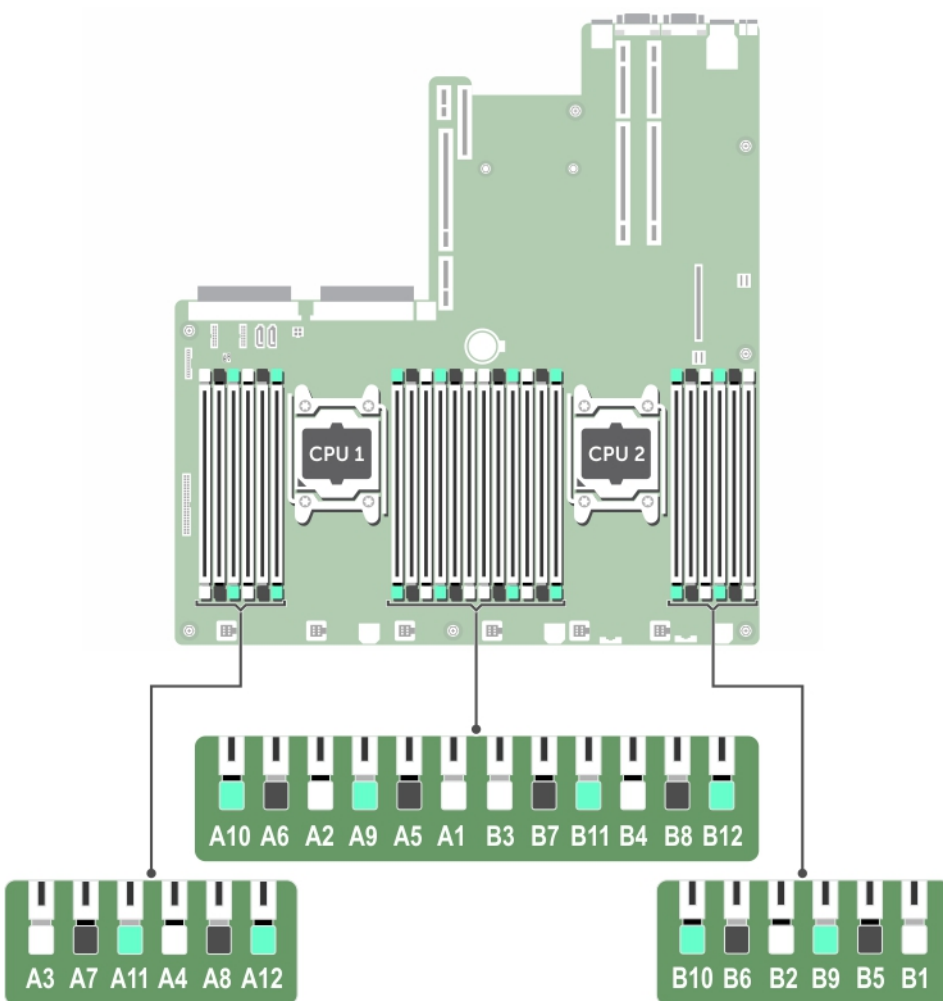

Memory channels are organized as follows:

Processor 1	Channel 0: slots A1, A5, and A9
	Channel 1: slots A2, A6, and A10
	Channel 2: slots A3, A7, and A11
	Channel 3: slots A4, A8, and A12

Processor 2	Channel 0: slots B1, B5, and B9
	Channel 1: slots B2, B6, and B10
	Channel 2: slots B3, B7, and B11
	Channel 3: slots B4, B8, and B12

The following table shows the memory populations and operating frequencies for the supported configurations.

DIMM Type	DIMMs Populated / Channel	Voltage	Operating Frequency (in MT/s)	Max. DIMM Rank / Channel
RDIMM	1	1.2V	2400, 2133, 1866	Dual Rank or Single Rank
	2		2400, 2133, 1866	Dual Rank or Single Rank
	3		1866	Dual Rank or Single Rank
LRDIMM	1	1.2V	2400, 2133, 1866	Quad Rank
	2		2400, 2133, 1866	Quad Rank
	3		2133, 1866	Quad Rank

General memory module installation guidelines

NOTE: Memory configurations that fail to observe these guidelines can prevent your system from booting, stop responding during memory configuration, or operating with reduced memory.

The system supports Flexible Memory Configuration, enabling the system to be configured and run in any valid chipset architectural configuration. The following are the recommended guidelines for installing memory modules:

- RDIMMs and LRDIMMs must not be mixed.
- x4 and x8 DRAM based memory modules can be mixed. For more information, see the Mode-specific guidelines section.
- Up to three dual- or single-rank RDIMMs can be populated per channel.
- Up to three LRDIMMs can be populated per channel regardless of rank count.
- If memory modules with different speeds are installed, they will operate at the speed of the slowest installed memory module(s) or slower depending on system DIMM configuration.
- Populate memory module sockets only if a processor is installed. For single-processor systems, sockets A1 to A12 are available. For dual-processor systems, sockets A1 to A12 and sockets B1 to B12 are available.
- Populate all the sockets with white release tabs first, followed by the black release tabs, and then the green release tabs.
- When mixing memory modules with different capacities, populate the sockets with memory modules with highest capacity first. For example, if you want to mix 4 GB and 8 GB memory modules, populate 8 GB memory modules in the sockets with white release tabs and 4 GB memory modules in the sockets with black release tabs.
- In a dual-processor configuration, the memory configuration for each processor should be identical. For example, if you populate socket A1 for processor 1, then populate socket B1 for processor 2, and so on.
- Memory modules of different capacities can be mixed provided other memory population rules are followed (for example, 4 GB and 8 GB memory modules can be mixed).
- Mixing of more than two memory module capacities in a system is not supported.
- Populate four memory modules per processor (one DIMM per channel) at a time to maximize performance.

Related references

[Mode-specific guidelines](#)

Mode-specific guidelines

Four memory channels are allocated to each processor. The allowable configurations depend on the memory mode selected.

Advanced Error Correction Code

Advanced Error Correction Code (ECC) mode extends SDDC from x4 DRAM based DIMMs to both x4 and x8 DRAMs. This protects against single DRAM chip failures during normal operation.

The installation guidelines for memory modules are as follows:

- Memory modules must be identical in size, speed, and technology.
- DIMMs installed in memory sockets with white release levers must be identical and the same rule applies for sockets with black release levers. This ensures that identical DIMMs are installed in matched pair—for example, A1 with A2, A3 with A4, A5 with A6, and so on.

Memory optimized independent channel mode

This mode supports Single Device Data Correction (SDDC) only for memory modules that use x4 device width. It does not impose any specific slot population requirements.

Memory sparing

NOTE: To use memory sparing, this feature must be enabled in System Setup.

In this mode, one rank per channel is reserved as a spare. If persistent correctable errors are detected on a rank, the data from this rank is copied to the spare rank, and the failed rank is disabled.

With memory sparing enabled, the system memory available to the operating system is reduced by one rank per channel. For example, in a dual-processor configuration with sixteen 4 GB single-rank memory modules, the available system memory is: 3/4 (ranks/channel) × 16 (memory modules) × 4 GB = 48 GB, and not 16 (memory modules) × 4 GB = 64 GB.

NOTE: Memory sparing does not offer protection against a multi-bit uncorrectable error.

NOTE: Both Advanced ECC/Lockstep and Optimizer modes support memory sparing.

Memory mirroring

Memory mirroring offers the strongest memory module reliability mode compared to all other modes, providing improved uncorrectable multi-bit failure protection. In a mirrored configuration, the total available system memory is one half of the total installed physical memory. Half of the installed memory is used to mirror the active memory modules. In the event of an uncorrectable error, the system switches over to the mirrored copy. This ensures SDDC and multi-bit protection.

The installation guidelines for memory modules are as follows:

- Memory modules must be identical in size, speed, and technology.
- Memory modules installed in memory module sockets with white release levers must be identical and the same rule applies for sockets with black and green release tabs. This ensures that identical memory modules are installed in matched pairs—for example, A1 with A2, A3 with A4, A5 with A6, and so on.

Table 40. Processor configuration

Processor	Configuration	Memory population rules	Memory population information
Single CPU	Memory population order	{1,2}, {3,4}	See Memory mirroring note

Sample memory configurations

The following tables show sample memory configurations for one and two processor configurations that follow the appropriate memory guidelines.

NOTE: 1 R, 2 R, 4 R and 8 R in the following tables indicate single, dual, and quad-rank DIMMs respectively.

Table 41. Memory configurations—single processor

System capacity—in GB	DIMM size—in GB	Number of DIMMs	DIMM rank, organization, and frequency	DIMM slot population
4	4	1	1 R, x8, 2400 MT/s 1 R, x8, 2133 MT/s	A1
8	4	2	1 R, x8, 2400 MT/s 1 R, x8, 2133 MT/s	A1, A2
16	4	4	1 R, x8, 2400 MT/s 1 R, x8, 2133 MT/s	A1, A2, A3, A4
	8	2	1 R, x8, 2400 MT/s 1 R, x8, 2133 MT/s	A1, A2
24	4	6	1 R, x8, 2400 MT/s 1 R, x8, 2133 MT/s	A1, A2, A3, A4, A5, A6
48	4	12	1 R, x8, 1866 MT/s	A1, A2, A3, A4, A5, A6, A7, A8, A9, A10, A11, A12
	8	6	1 R, x8, 2400 MT/s 1 R, x8, 2133 MT/s	A1, A2, A3, A4, A5, A6
96	8	12	1 R, x8, 1866 MT/s	A1, A2, A3, A4, A5, A6, A7, A8, A9, A10, A11, A12
	16	6	2 R, x8, 2400 MT/s 2 R, x8, 2133 MT/s	A1, A2, A3, A4, A5, A6
128	16	8	2 R, x8, 2400 MT/s 2 R, x8, 2133 MT/s	A1, A2, A3, A4, A5, A6, A7, A8
144	8	10	1 R, x8, 1866 MT/s	A1, A2, A3, A4, A5, A6, A7, A8, A9, A11*
	16	10	2 R, x8, 1866 MT/s	A1, A2, A3, A4, A5, A6, A7, A8, A9, A11*
256	32	8	2 R, x4, 2400 MT/s 2 R, x4, 2133 MT/s	A1, A2, A3, A4, A5, A6, A7, A8
384	32	12	2 R, x4, 1866 MT/s	A1, A2, A3, A4, A5, A6, A7, A8, A9, A10, A11, A12
512	64	8	4 R, x4, 2133 MT/s 4 R, x4, 2400 MT/s	A1, A2, A3, A4, A5, A6, A7, A8
768	64	12	4 R, x4, 1866 MT/s 4 R, x4, 2133 MT/s	A1, A2, A3, A4, A5, A6, A7, A8, A9, A10, A11, A12
1536	128	12	A1, A2, A3, A4, A5, A6, A7, A8, A9, A10, A11, A12	

* 16 GB DIMMs must be installed in slots numbered A1, A2, A3, A4, A5, A6, A7, and A8 and 8 GB DIMMs must be installed in slots A9 and A11.

NOTE: If all 3 slots in the channel are populated with 128 GB LRDIMMS, the clock speed drops to 2133MHz.

Table 42. Memory configurations—2 processors

System capacity— in GB	DIMM size —in GB	Number of DIMMs	DIMM rank, organization, and frequency	DIMM slot population
16	4	4	1 R, x8, 2400 MT/s 1 R, x8, 2133 MT/s	A1, A2, B1, B2
32	4	8	1 R, x8, 2400 MT/s 1 R, x8, 2133 MT/s	A1, A2, A3, A4, B1, B2, B3, B4
64	4	16	1 R, x8, 2400 MT/s 1 R, x8, 2133 MT/s	A1, A2, A3, A4, A5, A6, A7, A8, B1, B2, B3, B4, B5, B6, B7, B8
	8	8	1 R, x8, 2400 MT/s 1 R, x8, 2133 MT/s	A1, A2, A3, A4, B1, B2, B3, B4
96	4	24	1 R, x8, 1866 MT/s	A1, A2, A3, A4, A5, A6, A7, A8, A9, A10, A11, A12, B1, B2, B3, B4, B5, B6, B7, B8, B9, B10, B11, B12
	8	12	1 R, x8, 2400 MT/s 1 R, x8, 2133 MT/s	A1, A2, A3, A4, A5, A6, B1, B2, B3, B4, B5, B6
128	8	16	1 R, x8, 2400 MT/s 1 R, x8, 2133 MT/s	A1, A2, A3, A4, A5, A6, A7, A8, B1, B2, B3, B4, B5, B6, B7, B8
	16	8	2 R, x8, 2400 MT/s 2 R, x8, 2133 MT/s	A1, A2, A3, A4, B1, B2, B3, B4
160	8	20	1 R, x8, 1866 MT/s	A1, A2, A3, A4, A5, A6, A7, A8, A9, A10, B1, B2, B3, B4, B5, B6, B7, B8, B9, B10
192	8	24	1 R, x8, 1866 MT/s	A1, A2, A3, A4, A5, A6, A7, A8, A9, A10, A11, A12, B1, B2, B3, B4, B5, B6, B7, B8, B9, B10, B11, B12
	16	12	2 R, x8, 2400 MT/s 2 R, x8, 2133 MT/s	A1, A2, A3, A4, A5, A6, B1, B2, B3, B4, B5, B6
256	16	16	2 R, x8, 2400 MT/s 2 R, x8, 2133 MT/s	A1, A2, A3, A4, A5, A6, A7, A8, B1, B2, B3, B4, B5, B6, B7, B8
384	16	24	2 R, x8, 1866 MT/s	A1, A2, A3, A4, A5, A6, A7, A8, A9, A10, A11, A12, B1, B2, B3, B4, B5, B6, B7, B8, B9, B10, B11, B12
	32	12	2 R, x4, 2400 MT/s 2 R, x4, 2133 MT/s	A1, A2, A3, A4, A5, A6, B1, B2, B3, B4, B5, B6
512	32	16	2 R, x4, 2400 MT/s 2 R, x4, 2133 MT/s	A1, A2, A3, A4, A5, A6, A7, A8, B1, B2, B3, B4, B5, B6, B7, B8
	64	8	4 R, x4, 2400 MT/s 4 R, x4, 2133 MT/s	A1, A2, A3, A4, B1, B2, B3, B4

Table 42. Memory configurations—2 processors (continued)

System capacity—in GB	DIMM size—in GB	Number of DIMMs	DIMM rank, organization, and frequency	DIMM slot population
768	32	24	2 R, x4, 1866 MT/s	A1, A2, A3, A4, A5, A6, A7, A8, A9, A10, A11, A12, B1, B2, B3, B4, B5, B6, B7, B8, B9, B10, B11, B12
1024	64	16	4 R, x4, 2133 MT/s 4 R, x4, 2400 MT/s	A1, A2, A3, A4, A5, A6, A7, A8, B1, B2, B3, B4, B5, B6, B7, B8
1536	64	24	4 R, x4, 1866 MT/s 4 R, x4, 2133 MT/s	A1, A2, A3, A4, A5, A6, A7, A8, A9, A10, A11, A12, B1, B2, B3, B4, B5, B6, B7, B8, B9, B10, B11, B12
3072	128	24	A1, A2, A3, A4, A5, A6, A7, A8, A9, A10, A11, A12, B1, B2, B3, B4, B5, B6, B7, B8, B9, B10, B11, B12	

* 16 GB DIMMs must be installed in slots numbered A1, A2, A3, A4, B1, B2, B3, and B4 and 8 GB DIMMs must be installed in slots A5, A6, B5, and B6.

NOTE: If all 3 slots in the channel are populated with 128 GB LRDIMMS, the clock speed drops to 2133MHz.

Storage

The **Dell PowerEdge R630** provides storage expandability that allows customer to adapt to their workload and operational demands. With comprehensive storage options, the R630 offers various drive types, internal and external storage controllers, and different chassis and backplanes for varied numbers of drives.

Features such as Express Flash PCIe solid-state drives provide vastly accelerated performance over previous technologies. Dell Express Flash drives use PCIe lanes to connect directly to the processor and chipset and are easily accessible through a hot-plug drive bay.

All hard drives connect to the system board by using the hard drive backplane. Hard drives are supplied in hot-swappable hard-drive carriers that fit in the hard-drive slots.

CAUTION: Before attempting to remove or install a hard drive while the system is running, see the documentation for the storage controller card. Ensure the host adapter is configured correctly to support hot-swap hard drive removal and insertion.

CAUTION: Do not turn off or reboot your system while the hard drive is being formatted. Doing so can cause a hard drive failure.

NOTE: Use only hard drives that have been tested and approved for use with the hard-drive backplane.

When you format a hard drive, allow enough time for the formatting to be completed. Be aware that high-capacity hard drives can take a number of hours to format.

Backplane

The Dell PowerEdge R630 is available in several hot- plug, hard- drive chassis options, as detailed in the table below.

NOTE: The chassis option must be selected during purchase and cannot be changed or upgraded later.

Storage Options					
Config #	Chassis	Controller Qty	Base Config #	Backplane Description	Storage Controller(s)
1	R630	1	ASSY,CHAS,2.5X8, R630 2 PCIe Slots	8 X 2.5 SAS/SATA BP	PERC S130, H330, H730, H730P
2	R630	1	ASSY,CHAS,2.5X8, R630 3 PCIe Slots	8 X 2.5 SAS/SATA BP	PERC S130, H330, H730, H730P
3	R630	1	ASSY,CHAS,2.5X10 ,R630	10 X 2.5" SAS/ SATA BP	PERC H330, H730, H730P
4	R630	1	ASSY,CHAS,2.5X6 +4,R630	10 X 2.5" SAS/ SATA BP w/ PCIe SSD	PERC H330, H730, H730P
5	R630	1 or 2	ASSY,CHAS,1.8X24 ,R630	24 X 1.8" SATA BP	PERC H330, H730, H730P

SAS Backplane Features

All backplanes with eight or fewer hard drive slots have SEP circuitry implemented. For R630, because of power- and planar space limitations, all backplanes implement a 5V VR on the backplane, accommodate for the backplane HDD count. 12 V power is delivered through Power cable(s) to the backplanes.

All backplanes use a common sideband connector and connector pin-out for miscellaneous signals and I2C signals from the system iDRAC to the SEP. The sideband connector also carries 3.3V for all SAS backplanes. One pin is reserved for 3.3V AUX. This pin is left as no-connect on the SAS backplanes. On the PCIe backplane, the 3.3V AUX is routed to each SSD drive. This enables the SSD slot being PCIe slot specific capable.

All SAS backplanes are designed and validated to meet 12Gbps SAS and 6Gbps SATA requirements.

SAS Expander Daughter Card

The SAS expander daughter card is necessary to achieve higher single-volume hard drive configurations. An integrated expander device limits the hard drive footprint. A daughter card allows PowerEdge R730 and R730xd to maximize the hard drive space in the hard drive bay.

A single expander daughter card supports the 16 hard drive configuration. The expander daughter card is integrated with the 16 hard drive primary backplane by using Xcede HD and power connectors.

The key implementation features of the Expander Daughter Card are:

- Four 4x MiniSAS connectors: two for the internal storage controller, and two for an optional daisy chain board to extend the HDD count.
- One eSATA port footprint (not populated for OEM solutions with x36 expander).
- One LSI SAS3 x36 Edge Expander:
 - Provide connection between initiators and targets.
 - Support SSP, STP, and SMP protocols.
 - Internal BP SEP that communicates with the RAID controller by using SES pages over i2C and with the system iDRAC over i2C.
 - Support 12 Gbps SAS, 12 Gbps SAS and 6 Gbps SATA.
- Expander Flash ROM:
 - 4 MB part. Stores the expander firmware image.
- Xcede connectors for low speed misc. signals and high speed SAS signals between the DC and the primary backplane.
- Internal Expander SEP for platform specific firmware settings.

Active backplane with the expansion redriver card is supported.

PERC9

The **Dell™ PowerEdge™ Expandable RAID Controller (PERC) 9** is a refresh of Dell PERC portfolio in support of Dell's 13G PowerEdge servers, encompassing both hardware changes and firmware updates, while continuing support SAS, SATA and Solid State Drive (SSD) devices internal to Dell PowerEdge servers. The PERC9 series of cards consist of the H330, H730, H730P, and H830 cards.

NOTE: This is an overview of PERC9. For a full technology training on PERC9, please refer to the reference material link below.

Internal Link: [PERC9](#)

External Link: [PERC9](#)

PERC H330

The PERC H330 is a general purpose RAID solution card. The card is available in Adapter (low profile and full height), Mini Modular, and Mini Monolithic form factors for internal storage and tape devices.

PERC H730

The PERC H730 is a RAID solution card consisting of 512MB or 1GB Non-Volatile Cache and is available in the Adapter (low profile and full height), Mini Modular, and Mini Monolithic form factors for internal storage.

PERC H730P

The PERC H730P is the performance RAID solution card consisting of 1GB or 2GB Non-Volatile Cache and is available in the Adapter (low profile and full height), Mini Modular, and Mini Monolithic form factors for internal storage.

PERC H830

The PERC H830 is similar to the H730P solution, except that it supports external storage. The PERC H830 is only available in the Adapter (low profile and full height) form factor.

Power Supplies

Energy Smart power supplies have intelligent features, such as the ability to dynamically optimize efficiency while maintaining availability and redundancy. Also featured are enhanced power- consumption reduction technologies, such as high- efficiency power conversion and advanced thermal-management techniques, and embedded power-management features, including high-accuracy power monitoring.

NOTE: For more information on PSU firmware update, please refer to reference material link below.

Internal Link: [Dell PowerEdge 12G and 13G Power Supply Unit Firmware Update](#)

External Link: [Dell PowerEdge 12G and 13G Power Supply Unit Firmware Update](#)

The following power supply unit options are available for the R630:

- 495 W AC
- 750 W AC
- 1100 W AC
- 1100 W DC

NOTE: A 750 W AC/DC Mixed Mode power supply is available in China only.



Power Supply Efficiency

The **Dell™ PowerEdge™ R630** supports up to two AC or DC power supplies with 1 + 1 redundancy, auto sensing, and auto-switching capability.

The following table lists the Dell power supply units that have achieved Platinum and Titanium efficiency levels.

Power Supply Efficiency						
Form Factor	Output	Class	10%	20%	50%	100%
Redundant 86mm	495 W AC	Platinum	82.0%	90.0%	94.0%	91.0%
	750 W AC	Titanium	90.0%	94.0%	96.0%	91.0%
	750 W AC	Platinum	82.0%	90.0%	94.0%	91.0%
	1100 W AC	Platinum	89.0%	93.0%	94.5%	92.0%
	1100 W DC	N/A	80.0%	88.0%	91.0%	88.0%

Internal Dual SD Module

The Internal Dual SD Module (iDSDM) is included on mainstream 2 socket servers following the same behavior as 12G iDSDM. Customers can use iDSDM with a single SD card in either slot or in redundant mode with two SD cards installed.

The Internal Dual SD Module (iDSDM) card provides the following major functions:

- Dual SD interface, maintained in a mirrored configuration (primary and secondary SD).
- The iDSDM card does provide full RAID-1 functionality.
- Dual SD cards are not required. The module can operate with only one card, but will provide no redundancy.
- iDSDM will enable support for Secure Digital eXtended Capacity (SDXC) cards.
- USB interface to host system.
- I2C interface to host system and onboard EEPROM for out-of-band status reporting.
- Onboard LEDs showing status of each SD card.

iDSDM New Features

The following table lists the new features of iDSDM on 13G systems.

Table 43. iDSDM New Features

iDSDM New Features	
New Features	Description
Support for RAID and Data Integrity	13G iDSDM implements RAID functionality. This means that at any given time, after rebuild, contents will stay synchronized. If RAID feature is enabled, writes to iDSDM will perform write operation to both SD cards simultaneously.
	Support to ensure data integrity during power loss conditions is implemented.
Support for USB 3.0 (Higher Bandwidth)	System will work with USB 3.0. If USB 3.0 is disabled, or if there is an error on USB 3.0 is detected, iDSDM will fall back to USB 2.0.
User Prioritized SD Slots	User will be able to define which SD slot is primary.
	Once primary SD slot is selected, iDSDM will perform operation using that SD card.
	If RAID is enabled, content of primary SD card will be mirrored on secondary SD card.
Bad Block Management	Unlike 12G where a single bad sector will cause SD card to be considered "Failed", 13G iDSDM implements more robust mechanism for bad block management.
	This means SD cards failing on 12G might be functional on 13G iDSDM.
	Multiple read/write needs to happen before SD card is considered to be in failed state.
No More BIOS Halt During Rebuild	Unlike 12G, 13G iDSDM does not require the BIOS to halt during POST and wait for the rebuild to complete.
	Rebuild will happen in background and is much faster as compared to 12G. An 8GB card should be rebuilt in less than 30 minutes.
Enhanced Support for Mismatched SD Cards	Functionality of primary SD card will not be compromised if the secondary SD card has a different speed or lower storage.
	Mismatch check will only happen if the iDSDM is operating in RAID mode.

Table 43. IDSDM New Features (continued)

IDSDM New Features	
New Features	Description
	Only secondary SD card will be placed in mismatch state. If the secondary card does not match the speed or has lower storage capacity than the primary card, the secondary card will be placed in the MISMATCH state.
Enhanced Support for Write-Protected SD Cards	<p>After insertion, a card is determined to be in WRITE PROTECTED state if write protect notch is enabled.</p> <p>Cards in the WRITE PROTECTED state will be treated as Read Only. If at least one card is in the WRITE PROTECTED state and RAID is enabled, the iDSDM will operate in the degraded RAID state. RAID will automatically be disabled if both cards are in this state.</p>
Seamless SD Card Assignments	<p>IDSDM will bring secondary SD card online and will make it primary if, for some reason, primary SD card fails.</p> <p>If RAID is enabled, there will be no compromise in functionality however, system will notify user of degraded RAID status.</p>
Enriched Error Reporting	<p>New errors have been implemented to help root cause a failure.</p> <p>Failures will be in iDRAC logs.</p> <p>Multiple failures can be now recorded and logged.</p>
Mass Erase for Enhanced Security	Mass erase options are provided in iDSDM. Enabling this register will clean up all the data preset on SD cards.
UHS-1 SD Card Support	New to 13G. Was not supported on 12G.

Supported Operating Systems

The following operating systems are supported on IDSDM.

- VMWare® ESXi 5.1 and above
- Citrix XenServer® 6.1 and above
- Windows® Hyper-V Server 2008 R2 (not supported by Dell)
- Windows® 2012 Hyper-V Core (not supported by Dell)

PCIe Risers and Slots

Expansion Card Installation Guidelines

The following PCI Express Generation 3 expansion cards are supported:

Supported Expansion Cards						
Riser	PCIe Slot	Processor Connection	Height	Length	Link Width	Slot Width
1	1	Processor 2	Low Profile	Half Length	x16	x16
1	2	Processor 2	Low Profile	Half Length	x8	x16
3	3	Processor 1	Low Profile	Half Length	x16	x16
2	1	Processor 1	Low Profile	Half Length	x8	x16

Supported Expansion Cards						
Riser	PCIe Slot	Processor Connection	Height	Length	Link Width	Slot Width
		Processor 2	Low Profile	Half Length	x16	x16
3	2	Processor 1	Full Height	Three-quarters Length	x16	x16

NOTE: Both the processors must be installed to use riser 1 slots.

NOTE: Only a three-fourth length card is supported for the PCIe expansion card slot (slot 2) on riser 3.

NOTE: For a server with three PCIe cards, only Mini SAS HD third party cards are supported in slot 3. For a server with two PCIe cards, only Mini SAS HD third party cards are supported in slot 1.

NOTE: You can install expansion cards only on one slot on riser 2.

NOTE: Both the processors must be installed to use the x16 link on the riser 2 slot.

The following table provides a guide for installing expansion cards to ensure proper cooling and mechanical fit. The expansion cards with the highest priority must be installed first using the slot priority indicated. All other expansion cards must be installed in card priority and slot priority order.

Expansion Card Installation Order					
Card Priority	Card Type	Systems Supporting up to 2 PCIe Expansion Cards		Systems Supporting up to 3 PCIe Expansion Cards	
		Slot Priority	Max Allowed	Slot Priority	Max Allowed
1	PCIe Bridge	N/A	N/A	1	1
2	RAID	1	1	3,1	2
3	40 Gb NICs	2,1	1	3,2	1
4	10 Gb NICs)	2,1	1	3,2,1	3
5	FC16 HBA	2, 1	1	3,2,1	1
6	FC8 HBA	2, 1	1	3,2,1	3
7	FC4 HBA	2, 1	1	3,2,1	3
8	FC16 HBA	2, 1	1	N/A	N/A
9	1 Gb NICs	2, 1	1	3,2,1	3
10	Non-RAID	2	1	N/A	N/A
11	Integrated RAID	Integrated Slot	1	Integrated slot	1
12	NDC	Integrated slot	1	Integrated slot	1

For more information on the PowerEdge R630 slot priority matrix, refer to the [PowerEdge_R630_Slot_Priority_Matrix](#) document

Network Daughter Card

The **Dell PowerEdge R630** offer balanced, scalable I/O capabilities, including integrated PCIe 3.0- capable expansion slots. Dell Select Network Adapters, NDCs of Dell, let you choose the right network fabric without using a valuable PCI slot. Select the speed, technology, vendor, and other options, such as switch-independent partitioning, which will let you share and manage bandwidth on 10 GbE connections.

Select Network Adapters

The Select Network Adapter family is purpose-built and includes flexible LAN on Motherboard (LOM) card options for PowerEdge 13th generation servers. The Select Network Adapter form factor delivers the value of LOM integration with the system, including BIOS integration and shared port for manageability while providing the flexibility of a modular card.

The PowerEdge R630 supports one custom NDC, as part of the Select Network Adapters family, to house the complete LOM subsystem. There are two form factors of Select Network Adapters—one for blade servers and one for rack servers. The rack NDC options supported on the PowerEdge R630 include a selection of 1 GbE and 10 GbE port cards, such as 1000BASE-T, 10GBase-T, and 10Gb SFP+.

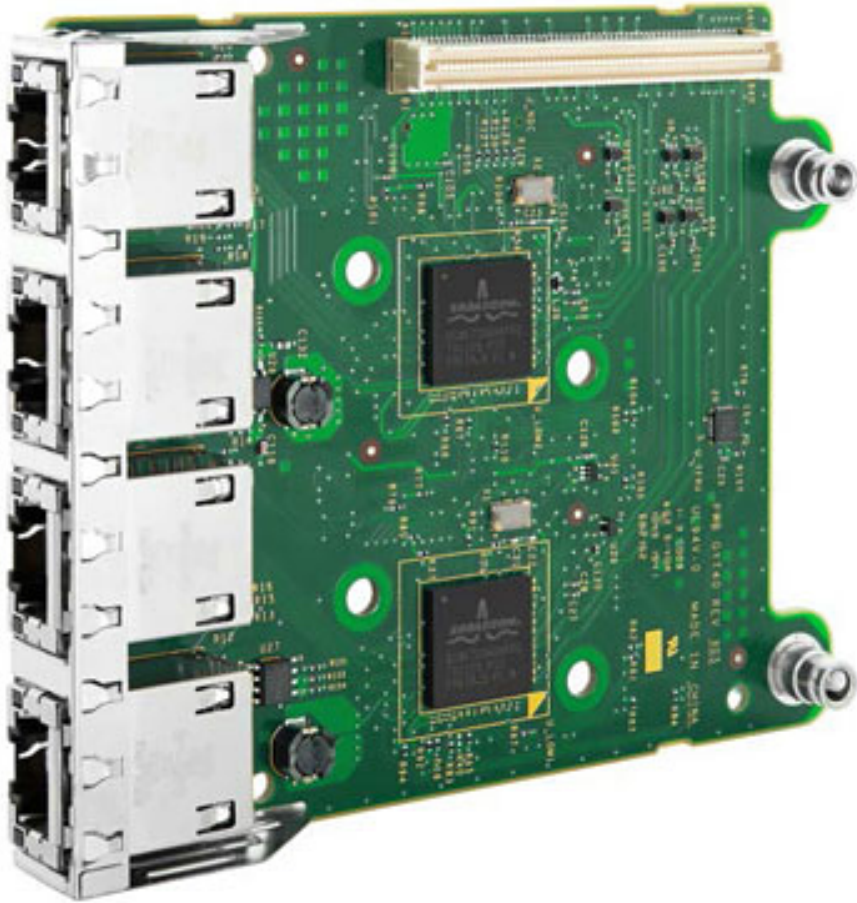

Customer Benefits

Offers Flexibility

- 1 GbE to 10 GbE transition
- SFP+ to Base-T (Rack) and KR (Blade)
- Vendor choice (Broadcom, Intel, Emulex)

Features

- Fibre Channel over Ethernet (FCoE)
- iSCSI
- Switch Independent Partitioning
- Data Center Bridging (DCB)

Supported Network Daughter Card

The following table lists the available Select Network Adapter options and supported features for the PowerEdge R630.

Supported Select Network Adapter Options and Features					
Features	Broadcom 5730 Base-T	Intel 1350 Base-T	Broadcom 57800 SFP+	Broadcom 57800 Base-T	Intel X540 Base-T
Link Speed	10/100/1000 Mbps	10/100/1000 Mbps	100 Mbps/1G/10G	100 Mbps/1G/10G	100 Mbps/1G/10G
Link Type	1000BASE-T	1000BASE-T	10GBASE-T, SFP+ DCA/SR	10GBASE-T, SFP+ DCA/SR	10GBASE-T, SFP+ DCA/SR
TCP Chimney (TOE)	Not Supported	Not Supported	Supported	Supported	Supported
iSCSI Offload	Not Supported	Not Supported	Supported	Supported	Supported
FCoE Offload	Not Supported	Not Supported	Supported	Supported	Supported
NetQueue/VMQ IOV	Not Supported	Not Supported	Supported	Supported	Supported
SR-IOV	Not Supported	Not Supported	Supported	Supported	Supported
NIC Partitioning (NPAR)	Not Supported	Not Supported	Supported	Supported	Supported
VNTag/VEB	Not Supported	Not Supported	Supported	Supported	Supported
Energy Efficient Ethernet	Not Supported	Not Supported	Not Supported	Not Supported	Not Supported
Stateless Offloads (RSS, CSO, LSO, LRO)	Supported	Supported	Supported	Supported	Supported
NC-SI Passthru and SEM	Supported	Supported	Supported	Supported	Supported

NOTE:

- These cards have two chipsets that offer the choice of either 10 GbE or 1 GbE.
- Only 10 Gb ports have iSCSI HBA support.
- Only 10 Gb ports have FCoE support.
- Only 10 GbE ports have switch independent partitioning support. The maximum number of partitions supported is four (two partitions per 10 Gb port). 1 Gb ports do not support switch-independent partitioning.
- Only 10 GbE ports have DCB support.
- Only 10 GbE ports have iSCSI TLV support.

System Management Integration

With the R630, the job of deploying, updating, monitoring, and maintaining the Select Network Adapters is fast and easy.

System management integration features include the following:

- Pre-boot: Use the Dell Lifecycle Controller graphical user interface (GUI) to set configuration such as bandwidth allocation or firmware revision level
- Post-boot: Agent-free out-of-band or high-speed in-band connection over LOM through the Operating System or BMC pass-thru feature for sensory information
- Automation of firmware and driver version deployment upon component replacement
- Automatic monitoring of NIC status and notification on SNMP traps
- Local- or remote reconfiguration of any NIC: physical or virtual
- PXE boot enabled on all LOM and NDCs for ease of use
- Boot from SAN (iSCSI, or FCoE) configuration for networking devices through the Lifecycle Controller GUI

Video

The Dell PowerEdge R630 iDRAC8 incorporate an integrated video subsystem. The graphics controller is the 2D Matrox G200. The video frame buffer (16MB) is contained within the iDRAC RAM (256MB) device.

The following table lists the 2D graphics supported video mode on R630 systems.

Supported Video Modes		
Resolution	Refresh Rate (Hz)	Color Depth (bit)
640 x 480	60, 70	8, 16, 32
800 x 600	60, 75, 85	8, 16, 32
1024 x 768	60, 75, 85	8, 16, 32
1152 x 864	60, 75, 85	8, 16, 32
1280 x 1024	60, 75	8, 16, 32
1440 x 900	60	8, 16, 32

Trusted Platform Module

The Trusted Platform Module (TPM) is used to generate and store keys, protect or authenticate passwords, and create and store digital certificates. The TPM can also be used to enable the Microsoft BitLocker hard drive encryption feature in Microsoft Windows Server 2008 and newer OS versions.

In 13th generation servers, the TPM chip is on the Plug-in Module (PIM). Unlike in 12 generation servers, the TPM chip is soldered on the system board. The 13 generation TPM has to be bounded to only one system board.

The system board has a connector for the plug-in module and it is factory-installed.

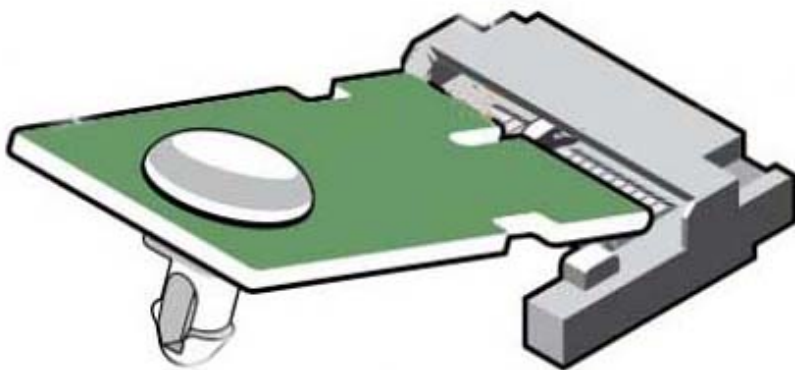

There are five types of TPM chip options:

- No TPM
- TPM 1.2 FIPS Nuvoton
- TPM 1.2 non FIPS Nuvoton
- TPM 2.0 ROW Nuvoton (Post-RTS)
- TPM 2.0 China NationZ (Post-RTS)

NOTE: TPM is an optional module for your system and is only available from the factory. It is not offered After Point of Sales (APOS).

NOTE: In a scenario where both the control panel and system board are dispatched, it is recommended to replace the control panel first and attempt a power-on to complete the Easy Restore process (Service Tag, licenses, copy to the new control panel). Then, proceed to replace the system board.

System Board Block Diagram

The following diagram shows the system board block diagram for Dell PowerEdge R630.

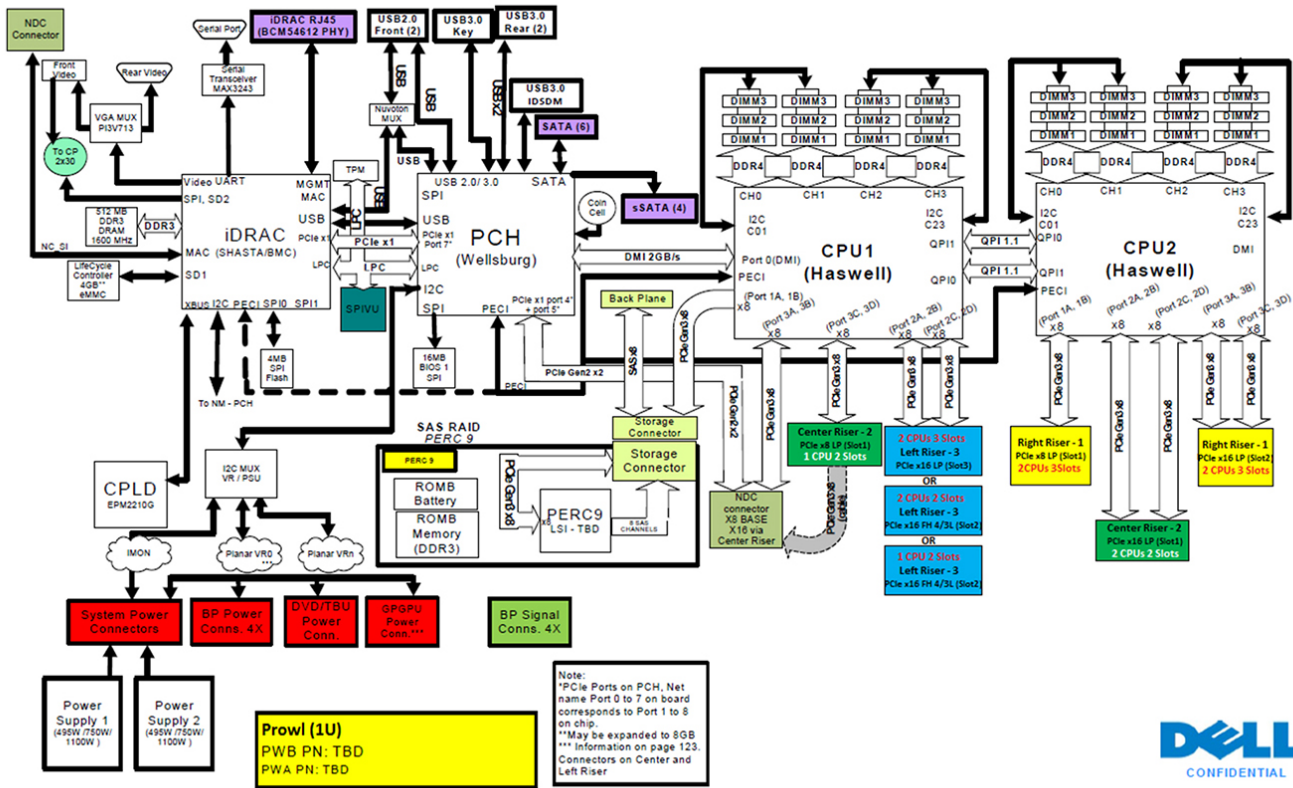

Using system diagnostics

If you experience a problem with your system, run the system diagnostics before contacting Dell for technical assistance. The purpose of running system diagnostics is to test your system hardware without using additional equipment or risking data loss. If you are unable to fix the problem yourself, service and support personnel can use the diagnostics results to help you solve the problem.

NOTE: For more information about OEM diagnostic event messages, see the Event and Error Message Reference Guide for 13th Generation Dell PowerEdge Servers Version 1.2

Topics:

- [Dell Embedded System Diagnostics](#)

Dell Embedded System Diagnostics

NOTE: The Dell Embedded System Diagnostics is also known as Enhanced Pre-boot System Assessment (ePSA) diagnostics.

The Embedded System Diagnostics provides a set of options for particular device groups or devices allowing you to:

- Run tests automatically or in an interactive mode
- Repeat tests
- Display or save test results
- Run thorough tests to introduce additional test options to provide extra information about the failed device(s)
- View status messages that inform you if tests are completed successfully
- View error messages that inform you of problems encountered during testing

Running the Embedded System Diagnostics from Boot Manager

Run the Embedded System Diagnostics (ePSA) if your system does not boot.

1. When the system is booting, press F10.
2. Use the up arrow and down arrow keys to select **System Utilities > Launch Diagnostics**.
The **ePSA Pre-boot System Assessment** window is displayed, listing all devices detected in the system. The diagnostics starts executing the tests on all the detected devices.

Running the Embedded System Diagnostics from the Dell Lifecycle Controller

1. As the system boots, press F10.
2. Select **Hardware Diagnostics → Run Hardware Diagnostics**.
The **ePSA Pre-boot System Assessment** window is displayed, listing all devices detected in the system. The diagnostics starts executing the tests on all the detected devices.

System diagnostics controls

Menu	Description
Configuration	Displays the configuration and status of all detected devices.
Results	Displays the results of all tests that are executed.

Menu	Description
System health	Provides the current overview of the system performance.
Event log	Displays a time-stamped log of the results of all tests run on the system. This is displayed if at least one event description is recorded.

Jumpers and connectors

This topic provides specific information about the jumpers. It also provides some basic information about jumpers and switches and describes the connectors on the various boards in the system. Jumpers on the system board help to disable the system and setup passwords. You must know the connectors on the system board to install components and cables correctly.





Topics:

- [System board jumper settings](#)
- [System board jumpers and connectors](#)
- [Disabling a forgotten password](#)

System board jumper settings

For information about resetting the password jumper to disable a password, see the [Disabling a forgotten password](#) section.

Table 44. System board jumper settings

Jumper	Setting	Description
PWRD_EN	 2 4 6 (default) (default)	The password feature is enabled (pins 4–6).
	 2 4 6	The password feature is disabled (pins 2–4). iDRAC local access is unlocked at the next AC power cycle.
NVRAM_CLR	 1 3 5 (default) (default)	The configuration settings are retained at system boot (pins 1–3).
	 1 3 5	The configuration settings are cleared at the next system boot (pins 3–5).

Related tasks

[Disabling a forgotten password](#)

System board jumpers and connectors

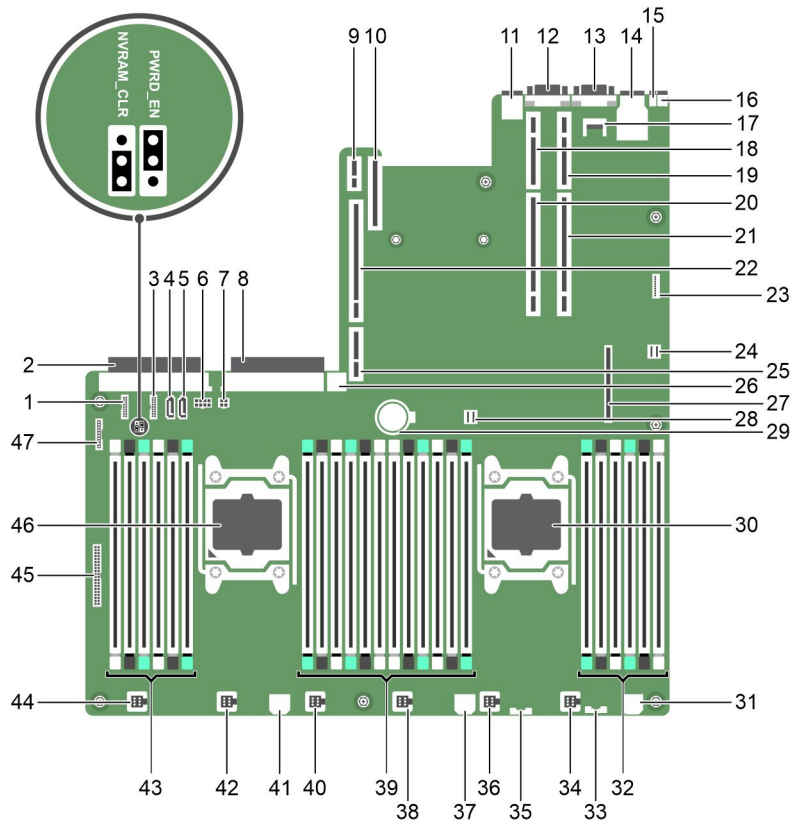

Figure 99. System board jumpers and connectors

Table 45. System board jumpers and connectors

Item	Connector	Description
1.	J_BP_SIG1	Backplane signal connector 1
2.	J_PS2	PSU 2 power connector
3.	J_BP_SIG0	Backplane signal connector 0
4.	J_SATA_CD	Optical drive SATA connector
5.	J_SATA_TBU	SATA tape backup unit connector
6.	J_BP0	Backplane power connector
7.	J_TBU	Tape backup unit power connector
8.	J_PS1	PSU 2 power connector
9.	J_IDSMD	Internal dual SD module connector
10.	J_NDC	Network daughter card connector
11.	J_USB	USB port
12.	J_VIDEO_REAR	Video connector
13.	J_COM1	Serial connector
14.	J_IDRAC_RJ45	iDRAC7 connector

Table 45. System board jumpers and connectors (continued)

Item	Connector	Description
15.	J_CYC	System identification connector
16.	CYC_ID	System identification button
17.	J_TPM_MODULE	Trusted Platform Module connector
18.	J_RISER_2AX	Riser 2 connector
19.	J_RISER_1AX	Riser 1 connector
20.	J_RISER_2BX	Riser 2 connector
21.	J_RISER_1BX	Riser 1 connector
22.	J_RISER_3AX	Riser 3 connector
23.	J_SATA_B	SATA connector
24.	J_QS	Quick Sync connector
25.	J_RISER_3BX	Riser 3 connector
26.	J_USB_INT	Internal USB port
27.	J_STORAGE	Storage controller card connector
28.	J_SATA_A	SATA connector
29.	BAT	Battery connector
30.	CPU2	Processor socket 2
31.	J_FAN1U_7	Cooling fan connector
32.	B1, B5, B9, B2, B6, B10	Memory module sockets
33.	J_BP3	Hard drive backplane power connector
34.	J_FAN1U_6	Cooling fan connector
35.	J_BP_SIG2	Backplane signal connector 2
36.	J_FAN1U_5	Cooling fan connector
37.	J_BATT_SIG	Battery signal connector
38.	J_FAN1U_4	Cooling fan connector
39.	A1, A5, A9, A2, A6, A10, B3, B7, B11, B4, B8, B12	Memory module sockets
40.	J_FAN1U_3	Cooling fan connector
41.	J_FAN2U	Cooling fan connector
42.	J_FAN1U_2	Cooling fan connector
43.	A12, A8, A4, A7, A11, A3	Memory module sockets
44.	J_FAN1U_1	Cooling fan connector
45.	J_CTRL_PNL	Control panel connector
46.	CPU1	Processor socket 1
47.	J_FP_USB	Front panel USB port

Disabling a forgotten password

The software security features include a system password and a setup password. The password jumper enables the password features or disables them and clears any passwords currently in use.

CAUTION: Many repairs may only be done by a certified service technician. You should only perform troubleshooting and simple repairs as authorized in your product documentation, or as directed by the online or telephone service and support team. Damage due to servicing that is not authorized by Dell is not covered by your warranty. Read and follow the safety instructions that are shipped with your product.

1. Turn off the system, including any attached peripherals, and disconnect the system from the electrical outlet.
2. Open the system.
3. Move the jumper on the system board jumper from pins 4 and 6 to pins 2 and 4.
4. Close the system.

The existing passwords are not disabled (erased) until the system boots with the jumper on pins 2 and 4. However, before you assign a new system and/or setup password, move the jumper back to pins 4 and 6.

NOTE: If you assign a new system and/or setup password with the jumper on pins 2 and 4, the system disables the new passwords the next time it boots.

5. Reconnect the system board jumper to its electrical outlet and turn on the system, including any attached peripherals.
6. Turn off the system, including any attached peripherals, and disconnect the system from the electrical outlet.
7. Open the system.
8. Move the jumper on the system board jumper from pins 2 and 4 to pins 4 and 6.
9. Close the system.
10. Reconnect the system to its electrical outlet and turn on the system, including any attached peripherals.
11. Assign a new system and/or setup password.

Troubleshooting your system

Safety first — for you and your system

CAUTION: Many repairs may only be done by a certified service technician. You should only perform troubleshooting and simple repairs as authorized in your product documentation, or as directed by the online or telephone service and support team. Damage due to servicing that is not authorized by Dell is not covered by your warranty. Read and follow the safety instructions that are shipped with your product.

NOTE: Solution validation was performed by using the factory shipped hardware configuration.

Topics:

- [Minimum configuration to POST](#)
- [Troubleshooting system startup failure](#)
- [Troubleshooting external connections](#)
- [Troubleshooting the video subsystem](#)
- [Troubleshooting a USB device](#)
- [Troubleshooting iDRAC Direct - USB XML configuration](#)
- [Troubleshooting iDRAC Direct - Laptop connection](#)
- [Troubleshooting a serial input and output device](#)
- [Troubleshooting a NIC](#)
- [Troubleshooting a wet system](#)
- [Troubleshooting a damaged system](#)
- [Troubleshooting the system battery](#)
- [Troubleshooting power supply units](#)
- [Troubleshooting cooling problems](#)
- [Troubleshooting cooling fans](#)
- [Troubleshooting system memory](#)
- [Troubleshooting an internal USB key](#)
- [Troubleshooting a micro SD card](#)
- [Troubleshooting an optical drive](#)
- [Troubleshooting a tape backup unit](#)
- [Troubleshooting a drive or SSD](#)
- [Troubleshooting a storage controller](#)
- [Troubleshooting expansion cards](#)
- [Troubleshooting processors](#)

Minimum configuration to POST

The components mentioned below are the minimum configuration to POST:

- One processor (CPU) in socket processor 1
- One memory module (DIMM) in socket A1
- One power supply unit
- Left control panel with cable (for power button functionality)
- System board

Troubleshooting system startup failure

If you boot the system to the BIOS boot mode after installing an operating system from the UEFI Boot Manager, the system stops responding. To avoid this issue, you must boot to the same boot mode in which you installed the operating system.

For all other startup issues, note the system messages that appear on the screen.

Troubleshooting external connections

Before troubleshooting any external devices, ensure that all external cables are securely attached to the external connectors on your system.

- Compare the technical specification of the system with the external device to check the compatibility.
- Check the external device functionality with some other similar system so that we are sure that the device is working correctly.
- Check any other similar external device with this system so that we are sure that the system port is working correctly.

For any further queries contact, [Contact Technical Support](#).

Troubleshooting the video subsystem

NOTE: Ensure that the **Local Server Video Enabled** option is selected in the iDRAC Graphical User Interface (GUI), under **Virtual Console**. If this option is not selected, local video is disabled.

NOTE: The VGA ports are not hot-pluggable.

1. Check the cable connections (power and display) to the monitor.
2. Check the video interface cabling from the system to the monitor.

If the tests run successfully, the problem is not related to video hardware.

If the tests fail, see the Getting help section.

Related references

[Getting help](#)

Troubleshooting a USB device

NOTE: Follow steps 1 to 6 to troubleshoot a USB keyboard or mouse. For other USB devices, go to step 7.

1. Disconnect the keyboard and/or mouse cables from the system and reconnect them.
2. If the problem persists, connect the keyboard and/or mouse to another USB port on the system.
3. If the problem is resolved, restart the system, enter System Setup, and check if the non-functioning USB ports are enabled.

NOTE: Older operating systems may not support USB 3.0.

4. Check if USB 3.0 is enabled in System Setup. If enabled, disable it and see if the issue is resolved.
5. In **iDRAC Settings Utility**, ensure that **USB Management Port Mode** is configured as **Automatic** or **Standard OS Use**.
6. If the problem is not resolved, replace the keyboard and/or mouse with a known working keyboard or mouse.
If the problem is not resolved, proceed to step 7 to troubleshoot other USB devices attached to the system.
If the problem is not resolved, proceed to troubleshoot other USB devices attached to the system.
7. Turn off all attached USB devices, and disconnect them from the system.
8. Restart the system.
9. If your keyboard is functioning, enter System Setup, verify that all USB ports are enabled on the **Integrated Devices** screen. If your keyboard is not functioning, use remote access to enable or disable the USB options.

10. Check if USB 3.0 is enabled in System Setup. If it is enabled, disable it and restart your system.
11. If the system is not accessible, reset the NVRAM_CLR jumper inside your system and restore the BIOS to the default settings. See the System board jumper setting section
12. In the **iDRAC Settings Utility**, ensure that **USB Management Port Mode** is configured as **Automatic** or **Standard OS Use**.
13. Reconnect and turn on each USB device one at a time.
14. If a USB device causes the same problem, turn off the device, replace the USB cable with a known good cable, and turn on the device.

If all troubleshooting fails, see the Getting help section.

Related concepts

[System Setup](#)

Related references

[Getting help](#)

[System board jumper settings](#)

Troubleshooting iDRAC Direct - USB XML configuration

For information about USB storage device and system configuration, see *Integrated Dell Remote Access Controller User's Guide* at www.dell.com/poweredge manuals

1. Ensure that your USB storage device is connected to the front USB Management Port, identified by  icon.
2. Ensure that your USB storage device is configured with an NTFS or an FAT32 file system with only one partition.
3. Verify that the USB storage device is configured correctly. For more information about configuring the USB storage device, see *Integrated Dell Remote Access Controller User's Guide* at www.dell.com/poweredge manuals
4. In the **iDRAC Settings Utility**, ensure that **USB Management Port Mode** is configured as **Automatic** or **iDRAC Direct Only**.
5. Ensure that the **iDRAC Managed: USB XML Configuration** option is either **Enabled** or **Enabled only when the server has default credential settings**.
6. Remove and reinsert the USB storage device.
7. If import operation does not work, try with a different USB storage device.

If all troubleshooting fails, see the Getting help section.

Related references

[Getting help](#)

Troubleshooting iDRAC Direct - Laptop connection

For information about USB laptop connection and system configuration, see the *Integrated Dell Remote Access Controller User's Guide* at www.dell.com/poweredge manuals.

1. Ensure that your laptop is connected to the front USB Management Port, identified by  icon with a USB Type A/A cable.
2. On the **iDRAC Settings Utility** screen, ensure that **USB Management Port Mode** is configured as **Automatic** or **iDRAC Direct Only**.
3. If the laptop is running Windows operating system, ensure that the iDRAC Virtual USB NIC device driver is installed.
4. If the driver is installed, ensure that you are not connected to any network through WiFi or cabled ethernet, as iDRAC Direct uses a non-routable address.

If all troubleshooting fails, see the Getting help section.

Related references

[Getting help](#)

Troubleshooting a serial input and output device

1. Turn off the system and any peripheral devices connected to the serial port.
2. Swap the serial interface cable with a known working cable, and turn on the system and the I/O serial device.
If the problem is resolved, replace the interface cable with a known working cable.
3. Turn off the system and the I/O serial device, and swap the serial device with a compatible device.
4. Turn on the system and the I/O serial device.

If the problem persists, see the Getting help section.

Related references

[Getting help](#)

Troubleshooting a NIC

 **NOTE:** Network Daughter Card (NDC) slot is not hot-pluggable.

1. Run the appropriate diagnostic test. For more information, see the Using system diagnostics section for the available diagnostic tests.
2. Restart the system and check for any system messages pertaining to the NIC controller.
3. Check the appropriate indicator on the NIC connector:
 - If the link indicator does not glow, the cable connected might be disengaged.
 - If the activity indicator does not glow, the network driver files might be damaged or missing. Install or replace the drivers as necessary. For more information, see the NIC documentation.
 - Try another known good network cable.
 - If the problem persists, use another connector on the switch or hub.
4. Ensure that the appropriate drivers are installed and the protocols are bound. For more information, see the NIC documentation.
5. Enter System Setup and confirm that the NIC ports are enabled on the **Integrated Devices** screen.
6. Ensure that all the NICs, hubs, and switches on the network are set to the same data transmission speed and duplex. For more information, see the documentation for each network device.
7. Ensure that all the NICs and switches on the network are set to the same data transmission speed and duplex. For more information, see the documentation for each network device.
8. Ensure that all network cables are of the proper type and do not exceed the maximum length.

If the problem persists, see the Getting help section.

Related references

[Getting help](#)

[Using system diagnostics](#)

Troubleshooting a wet system

 **CAUTION:** Many repairs may only be done by a certified service technician. You should only perform troubleshooting and simple repairs as authorized in your product documentation, or as directed by the online or telephone service and support team. Damage due to servicing that is not authorized by Dell is not covered by your warranty. Read and follow the safety instructions that are shipped with your product.

1. Turn off the system and attached peripherals, and disconnect the system from the electrical outlet.

2. Remove the system cover.
3. Remove the following components (if installed) from the system:
 - Power supply unit(s)
 - Optical drive
 - Hard drives
 - Hard drive backplane
 - USB memory key
 - Hard drive tray
 - Cooling shroud
 - Expansion card risers (if installed)
 - Expansion cards
 - Cooling fan assembly (if installed)
 - Cooling fan(s)
 - Memory modules
 - Processor(s) and heat sink(s)
 - System board
4. Let the system dry thoroughly for at least 24 hours.
5. Reinstall the components you removed in step 3 except the expansion cards.
6. Install the system cover.
7. Turn on the system and attached peripherals.
If the problem persists, see the Getting help section.
8. If the system starts properly, turn off the system, and reinstall all the expansion cards that you removed.
9. Run the appropriate diagnostic test. For more information, see the Using system diagnostics section.

If the tests fail, see the Getting help section.

Related references

[Getting help](#)

[Using system diagnostics](#)

Related tasks

[Removing the system cover](#)

[Installing the system cover](#)

[Removing the hard drive backplane](#)

[Replacing the optional internal USB memory key](#)

[Removing the cooling shroud](#)

[Removing memory modules](#)

[Removing a cooling fan](#)

[Removing an AC power supply unit](#)

[Removing a DC power supply unit](#)

[Removing expansion card risers](#)

[Removing an expansion card](#)

[Removing a heat sink](#)

[Removing a processor](#)

[Removing a hot swappable hard drive or solid state drive](#)

Troubleshooting a damaged system

 **CAUTION:** Many repairs may only be done by a certified service technician. You should only perform troubleshooting and simple repairs as authorized in your product documentation, or as directed by the online or telephone service and support team. Damage due to servicing that is not authorized by Dell is not covered by your warranty. Read and follow the safety instructions that are shipped with your product.

1. Turn off the system and attached peripherals, and disconnect the system from the electrical outlet.
2. Remove the system cover.
3. Ensure that the following components are properly installed:
 - cooling shroud
 - expansion card risers (if installed)
 - expansion cards
 - power supply unit(s)
 - cooling fan assembly (if installed)
 - cooling fan(s)
 - processor(s) and heat sink(s)
 - memory modules
 - drive carriers or cage
 - drive backplane
4. Ensure that all cables are properly connected.
5. Install the system cover.
6. Run the appropriate diagnostic test. For more information, see the Using system diagnostics section.

If the problem persists, see the Getting help section.

Related references

[Getting help](#)

[Using system diagnostics](#)

Related tasks

[Removing the system cover](#)

[Installing the system cover](#)

[Installing expansion card risers](#)

[Installing a processor](#)

[Installing a heat sink](#)

[Installing memory modules](#)

[Installing the cooling shroud](#)

[Installing an AC power supply unit](#)

[Installing a DC power supply unit](#)

[Installing an expansion card](#)

Troubleshooting the system battery

CAUTION: Many repairs may only be done by a certified service technician. You should only perform troubleshooting and simple repairs as authorized in your product documentation, or as directed by the online or telephone service and support team. Damage due to servicing that is not authorized by Dell is not covered by your warranty. Read and follow the safety instructions that are shipped with your product.

NOTE: If the system is turned off for long periods of time (for weeks or months), the NVRAM may lose the system configuration information. This situation is caused by a defective battery.

NOTE: Some software may cause the system time to speed up or slow down. If the system seems to operate normally except for the time set in System Setup, the problem may be caused by a software, rather than by a defective battery.

1. Re-enter the time and date in System Setup.
2. Turn off the system, and disconnect it from the electrical outlet for at least an hour.
3. Reconnect the system to the electrical outlet, and turn on the system.
4. Enter System Setup.

If the date and time displayed in System Setup are not correct, check the System Error Log (SEL) for system battery messages.

If the problem persists, see the Getting help section.

Related concepts

[System Setup](#)

Related references

[Getting help](#)

Troubleshooting power supply units

CAUTION: Many repairs may only be done by a certified service technician. You should only perform troubleshooting and simple repairs as authorized in your product documentation, or as directed by the online or telephone service and support team. Damage due to servicing that is not authorized by Dell is not covered by your warranty. Read and follow the safety instructions that are shipped with your product.

The following sections provide information on troubleshooting power source and power supply units problems.

NOTE: Power Supply Units (PSUs) are hot-pluggable.

Troubleshooting power source problems

1. Press the power button to ensure that your system is turned on. If the power indicator does not glow when the power button is pressed, press the power button firmly.
2. Plug in another working power supply unit to ensure that the system board is not faulty.
3. Ensure that no loose connections exist.
For example, loose power cables.
4. Ensure that the power source meets applicable standards.
5. Ensure that there are no short circuits.
6. Have a qualified electrician check the line voltage to ensure that it meets the needed specifications.

NOTE: Some power supply units require 200-240V AC to deliver their rated capacity. For more information, see the system Technical Specifications section in the Installation and Service Manual available at www.dell.com/poweredgemanuals.

Power supply unit problems

1. Ensure that no loose connections exist.
For example, loose power cables.
2. Ensure that the power supply unit (PSU) handle or LED indicates that the PSU is working properly.
For more information about PSU indicators, see the Power indicator codes section.
3. If you have recently upgraded your system, ensure that the PSU has enough power to support the new system.
4. If you have a redundant PSU configuration, ensure that both the PSUs are of the same type and wattage.
You may have to upgrade to a higher wattage PSU.
5. Ensure that you use only PSUs with the Extended Power Performance (EPP) label on the back.
6. Reseat the PSU.

NOTE: After installing a PSU, allow several seconds for the system to recognize the PSU and determine if it is working properly.

If the problem persists, see the Getting help section.

Related references

[Getting help](#)

[Power supply unit indicator codes](#)

Troubleshooting cooling problems

CAUTION: Many repairs may only be done by a certified service technician. You should only perform troubleshooting and simple repairs as authorized in your product documentation, or as directed by the online or telephone service and support team. Damage due to servicing that is not authorized by Dell is not covered by your warranty. Read and follow the safety instructions that are shipped with your product.

Ensure that the following conditions exist:

- System cover, cooling shroud, EMI filler panel, or back filler bracket is not removed.
- Ambient temperature is not higher than the system specific ambient temperature.
- External airflow is not obstructed.
- A cooling fan is not removed or has not failed.
- The expansion card installation guidelines have been followed.

Additional cooling can be added by one of the following methods:

From the iDRAC web GUI:

1. Click **Hardware > Fans > Setup**.
2. From the **Fan Speed Offset** drop-down list, select the cooling level that is required or set the minimum fan speed to a custom value.

From F2 System Setup:

1. Select **iDRAC Settings > Thermal**, and set a higher fan speed from the fan speed offset or minimum fan speed.

From RACADM commands:

1. Run the command `racadm help system.thermalsettings`

For more information, see *Integrated Dell Remote Access User's Guide* at www.dell.com/poweredgemanuals

Troubleshooting cooling fans

CAUTION: Many repairs may only be done by a certified service technician. You should only perform troubleshooting and simple repairs as authorized in your product documentation, or as directed by the online or telephone service and support team. Damage due to servicing that is not authorized by Dell is not covered by your warranty. Read and follow the safety instructions that are shipped with your product.

NOTE: The fan number is referenced by the management software of the system. In the event of a problem with a particular fan, you can easily identify and replace it by noting down the fan numbers on the cooling fan assembly.

1. Follow the safety guidelines listed in the Safety instructions section.
2. Follow the procedure listed in the Before working inside your system section.
 1. Reseat the fan or the fan's power cable.
 2. Restart the system.
1. Follow the procedure listed in the After working inside your system section.
2. If the problem persists, see the Getting help section.

Related references

[Safety instructions](#)

[Getting help](#)

Related tasks

[Before working inside your system](#)

[Removing the system cover](#)

[Installing the system cover](#)

[Installing a cooling fan](#)

Troubleshooting system memory

CAUTION: Many repairs may only be done by a certified service technician. You should only perform troubleshooting and simple repairs as authorized in your product documentation, or as directed by the online or telephone service and support team. Damage due to servicing that is not authorized by Dell is not covered by your warranty. Read and follow the safety instructions that are shipped with your product.

NOTE: Memory slots are not hot-pluggable.

NOTE: NVDIMM-N battery is not hot-pluggable.

1. If the system memory issue is associated with a MEM or UEFI event in the Lifecycle Log, follow the corrective actions that are provided in the event message. If the system is operational, run the appropriate diagnostic test. See the Using system diagnostics section for the available diagnostic tests.

If the diagnostic tests indicate a fault, follow the corrective actions that are provided by the diagnostic tests.

2. If the system is not operational, turn off the system and attached peripherals, and unplug the system from the power source. Wait at least for 10 seconds, and then reconnect the system to the power source.
3. Turn on the system and attached peripherals, and note the messages on the screen.

If an error message is displayed indicating a fault with a specific memory module, go to step 12.

4. Enter System Setup, and check the system memory setting. Make any changes to the memory settings, if needed.

If the memory settings match the installed memory but the problem still persists, go to step 12.

5. Turn off the system and attached peripherals, and disconnect the system from the electrical outlet.
6. Remove the system cover.
7. Check the memory channels and ensure that they are populated correctly.

NOTE: See the system event log or system messages for the location of the failed memory module. Reinstall the memory device.

8. Reseat the memory modules in their sockets.
9. Install the system cover.
10. Enter System Setup, and check the system memory setting.
If the problem is not resolved, proceed with step 11.
11. Remove the system cover.
12. If a diagnostic test or error message indicates a specific memory module as faulty, swap or replace the module with a known working memory module.
13. To troubleshoot an unspecified faulty memory module, replace the memory module in the first DIMM socket with a module of the same type and capacity.
If an error message is displayed on the screen, this may indicate a problem with one or more installed DIMM types, incorrect DIMM installation, or defective DIMMs. Follow the on-screen instructions to resolve the problem.
14. Install the system cover.
15. As the system boots, observe any error message that is displayed and the diagnostic indicators on the front of the system.
16. If the memory problem persists, repeat step 12 through step 15 for each memory module installed.

If the problem persists, see the Getting help section.

Related references

[Getting help](#)

[Using system diagnostics](#)

Related tasks

[Removing the system cover](#)

[Installing the system cover](#)

[Removing memory modules](#)

Troubleshooting an internal USB key

CAUTION: Many repairs may only be done by a certified service technician. You should only perform troubleshooting and simple repairs as authorized in your product documentation, or as directed by the online or telephone service and support team. Damage due to servicing that is not authorized by Dell is not covered by your warranty. Read and follow the safety instructions that are shipped with your product.

1. Enter System Setup and ensure that the **USB key port** is enabled on the **Integrated Devices** screen.
2. Turn off the system and attached peripherals, and disconnect the system from the electrical outlet.
3. Remove the system cover.
4. Locate the USB key and reseal it.
5. Install the system cover.
6. Turn on the system and attached peripherals, and check if the USB key is functioning.
7. If the problem is not resolved, repeat step 2 and step 3.
8. Insert a known working USB key.
9. Install the system cover.

If the problem persists, see the Getting help section.

Related concepts

[System Setup](#)

Related references

[Getting help](#)

[System board jumpers and connectors](#)

Related tasks

[Removing the system cover](#)

[Installing the system cover](#)

[Replacing the optional internal USB memory key](#)

Troubleshooting a micro SD card

NOTE: Certain micro SD cards have a physical write-protect power on the card. If the write-protect switch is turned on, the micro SD card is not writable.

NOTE: IDSDM and vFlash slots are not hot-pluggable.

1. Enter System Setup, and ensure that the **Internal SD Card Port** is enabled.
2. Turn off the system, including any attached peripherals, and disconnect the system from the electrical outlet.
3. Remove the system cover.
 - NOTE:** When an SD card failure occurs, the internal dual SD module controller notifies the system. On the next restart, the system displayed a message indicating the failure. If redundancy is enabled at the time of SD card failure, a critical alert is logged and chassis health will degrade.
4. Replace the failed micro SD card with a new micro SD card.
5. Install the system cover.
6. Reconnect the system to its electrical outlet and turn on the system, including any attached peripherals.
7. Enter System Setup, and ensure that the **Internal SD Card Port** and **Internal SD Card Redundancy** modes are set to the needed modes.

Verify that the correct SD slot is set as **Primary SD Card**.

8. Check if the micro SD card is functioning properly.
9. If the **Internal SD Card Redundancy** option is set to **Enabled** at the time of the SD card failure, the system prompts you to perform a rebuild.

 **NOTE:** The rebuild is always sourced from the primary SD card to the secondary SD card.

Related concepts

[System Setup](#)

Related tasks

[Removing the system cover](#)

[Installing the system cover](#)

Troubleshooting an optical drive

 **CAUTION:** Many repairs may only be done by a certified service technician. You should only perform troubleshooting and simple repairs as authorized in your product documentation, or as directed by the online or telephone service and support team. Damage due to servicing that is not authorized by Dell is not covered by your warranty. Read and follow the safety instructions that are shipped with your product.

1. Try using a different CD or DVD.
2. If the problem is not resolved, enter System Setup and ensure that the integrated SATA controller and the drive's SATA port are enabled.
3. Run the appropriate diagnostic test.
4. Turn off the system and attached peripherals, and disconnect the system from the electrical outlet.
5. If installed, remove the bezel.
6. Remove the system cover.
7. Ensure that the interface cable is securely connected to the optical drive and to the controller.
8. Ensure that a power cable is properly connected to the drive.
9. Install the system cover.

If the problem persists, see the Getting help section.

Related concepts

[System Setup](#)

Related references

[Getting help](#)

Related tasks

[Removing the system cover](#)

[Installing the system cover](#)

[Removing the optional front bezel](#)

[Installing the optional front bezel](#)

Troubleshooting a tape backup unit

 **CAUTION:** Many repairs may only be done by a certified service technician. You should only perform troubleshooting and simple repairs as authorized in your product documentation, or as directed by the online or

telephone service and support team. Damage due to servicing that is not authorized by Dell is not covered by your warranty. Read and follow the safety instructions that are shipped with your product.

1. Use a different tape cartridge.
2. Ensure that the device drivers for the tape backup unit are installed and are configured correctly. See your tape drive documentation for more information about device drivers.
3. Reinstall the tape-backup software as instructed in the tape-backup software documentation.
4. Ensure that the interface cable of the tape drive is connected to the external port on the controller card.
5. Perform the following steps to ensure that the controller card is properly installed:
 - a. Turn off the system and attached peripherals, and disconnect the system from the electrical outlet.
 - b. Remove the system cover.
 - c. Reseat the controller card in the expansion card slot.
 - d. Install the system cover.
 - e. Turn on the system and attached peripherals.
6. Run the appropriate diagnostic test. For more information, see the Using system diagnostics.

If you cannot resolve the problem, see the Getting help section.

Related references

[Getting help](#)

[Using system diagnostics](#)

Related tasks

[Removing the system cover](#)

[Installing the system cover](#)

Troubleshooting a drive or SSD

 **CAUTION:** This troubleshooting procedure can erase data stored on the drive. Before you proceed, back up all files on the drive.

 **CAUTION:** Many repairs may only be done by a certified service technician. You should only perform troubleshooting and simple repairs as authorized in your product documentation, or as directed by the online or telephone service and support team. Damage due to servicing that is not authorized by Dell is not covered by your warranty. Read and follow the safety instructions that are shipped with your product.

1. Run the appropriate diagnostic test. See the Using system diagnostics section.
Depending on the results of the diagnostics test, proceed as required through the following steps.
2. If your system has a RAID controller and your drives are configured in a RAID array, perform the following steps:
 - a. Restart the system and press F10 during system startup to run the Dell Lifecycle Controller, and then run the Hardware Configuration wizard to check the RAID configuration.
See the Dell Lifecycle Controller documentation or online help for information about RAID configuration.
 - b. Ensure that the drives are configured correctly for the RAID array.
 - c. Take the drive offline and reseat the drive.
 - d. Exit the configuration utility and allow the system to boot to the operating system.
3. Ensure that the needed device drivers for your controller card are installed and are configured correctly. For more information, see the operating system documentation.
4. Restart the system and enter the System Setup.
5. Verify that the controller is enabled and the drives are displayed in the System Setup.

If the problem persists, see the Getting help section.

Related concepts

[System Setup](#)

Related references

[Getting help](#)

[Using system diagnostics](#)

Troubleshooting a storage controller

CAUTION: Many repairs may only be done by a certified service technician. You should only perform troubleshooting and simple repairs as authorized in your product documentation, or as directed by the online or telephone service and support team. Damage due to servicing that is not authorized by Dell is not covered by your warranty. Read and follow the safety instructions that are shipped with your product.

NOTE: When troubleshooting a controller, see the documentation for your operating system and the controller.

NOTE: Both PERC connector and mini-Mezzanine connector are not hot-pluggable.

1. Run the appropriate diagnostic test. See the Using system diagnostics section.
2. Turn off the system and attached peripherals, and disconnect the system from the electrical outlet.
3. Remove the system cover.
4. Verify that the installed expansion cards are compliant with the expansion card installation guidelines.
5. Ensure that each expansion card is firmly seated in its connector.
6. Install the system cover.
7. Reconnect the system to the electrical outlet, and turn on the system and attached peripherals.
8. If the problem is not resolved, turn off the system and attached peripherals, and disconnect the system from the electrical outlet.
9. Remove the system cover.
10. Remove all expansion cards installed in the system.
11. Install the system cover.
12. Reconnect the system to the electrical outlet, and turn on the system and attached peripherals.
13. Run the appropriate diagnostic test. See the Using system diagnostics section.

If the tests fail, see the Getting help section.

14. For each expansion card you removed in step 10, perform the following steps:
 - a. Turn off the system and attached peripherals, and disconnect the system from the electrical outlet.
 - b. Remove the system cover.
 - c. Reinstall one of the expansion cards.
 - d. Install the system cover.
 - e. Run the appropriate diagnostic test. See the Using system diagnostics section.

If the problem persists, see the Getting help section.

Related references

[Getting help](#)

[Using system diagnostics](#)

Related tasks

[Removing the system cover](#)

[Installing the system cover](#)

[Removing an expansion card](#)

[Installing an expansion card](#)

Troubleshooting expansion cards

CAUTION: Many repairs may only be done by a certified service technician. You should only perform troubleshooting and simple repairs as authorized in your product documentation, or as directed by the online or

telephone service and support team. Damage due to servicing that is not authorized by Dell is not covered by your warranty. Read and follow the safety instructions that are shipped with your product.

i NOTE: When troubleshooting an expansion card, you also have to see the documentation for your operating system and the expansion card.

i NOTE: Riser slots are not hot-pluggable.

1. Run the appropriate diagnostic test. See the Using system diagnostics section.
2. Turn off the system and attached peripherals, and disconnect the system from the electrical outlet.
3. Remove the system cover.
4. Ensure that each expansion card is firmly seated in its connector.
5. Install the system cover.
6. Turn on the system and attached peripherals.
7. If the problem is not resolved, turn off the system and attached peripherals, and disconnect the system from the electrical outlet.
8. Remove the system cover.
9. Remove all expansion cards installed in the system.
10. Install the system cover.
11. Run the appropriate diagnostic test. See the Using system diagnostics section.

If the tests fail, see the Getting help section.

12. For each expansion card you removed in step 8, perform the following steps:
 - a. Turn off the system and attached peripherals, and disconnect the system from the electrical outlet.
 - b. Remove the system cover.
 - c. Reinstall one of the expansion cards.
 - d. Install the system cover.
 - e. Run the appropriate diagnostic test. See the Using system diagnostics section.

If the problem persists, see the Getting help section.

Related references

[Getting help](#)

[Using system diagnostics](#)

Related tasks

[Removing the system cover](#)

[Installing the system cover](#)

[Removing an expansion card](#)

[Installing an expansion card](#)

Troubleshooting processors

⚠ CAUTION: Many repairs may only be done by a certified service technician. You should only perform troubleshooting and simple repairs as authorized in your product documentation, or as directed by the online or telephone service and support team. Damage due to servicing that is not authorized by Dell is not covered by your warranty. Read and follow the safety instructions that are shipped with your product.

i NOTE: Processor sockets are not hot-pluggable.

1. Run the appropriate diagnostics test. See the Using system diagnostics section.
2. Turn off the system and attached peripherals, and disconnect the system from the electrical outlet.
3. Remove the system cover.
4. Ensure that the processor and heat sink are properly installed.
5. Install the system cover.

6. Run the appropriate diagnostic test. See the Using system diagnostics section.
7. If the problem persists, see the Getting help section.

Related references

[Getting help](#)

[Using system diagnostics](#)

Related tasks

[Removing the system cover](#)

[Installing the system cover](#)

Getting help

Topics:

- [Contacting Dell](#)
- [Documentation feedback](#)
- [Accessing system information by using QRL](#)

Contacting Dell

Dell provides several online and telephone based support and service options. If you do not have an active internet connection, you can find contact information about your purchase invoice, packing slip, bill, or Dell product catalog. Availability varies by country and product, and some services may not be available in your area. To contact Dell for sales, technical assistance, or customer service issues:

1. Go to www.dell.com/support/home.
2. Select your country from the drop-down menu on the lower right corner of the page.
3. For customized support:
 - a. Enter your system Service Tag in the **Enter your Service Tag** field.
 - b. Click **Submit**.
The support page that lists the various support categories is displayed.
4. For general support:
 - a. Select your product category.
 - b. Select your product segment.
 - c. Select your product.
The support page that lists the various support categories is displayed.
5. For contact details of Dell Global Technical Support:
 - a. Click [Contact Technical Support](#).
 - b. Enter your system Service Tag in the **Enter your Service Tag** field on the Contact Us webpage.

Documentation feedback

You can rate the documentation or write your feedback on any of our Dell documentation pages and click **Send Feedback** to send your feedback.

Accessing system information by using QRL

You can use the Quick Resource Locator (QRL) located on the information tag in the front of the system, to access the information about the PowerEdge system.

Ensure that your smartphone or tablet has the QR code scanner installed.

The QRL includes the following information about your system:

- How-to videos
 - Reference materials, including the Installation and Service Manual, LCD diagnostics, and mechanical overview
 - Your system service tag to quickly access your specific hardware configuration and warranty information
 - A direct link to Dell to contact technical assistance and sales teams
1. Go to www.dell.com/qrl and navigate to your specific product or
 2. Use your smartphone or tablet to scan the model-specific Quick Resource (QR) code on your system or in the Quick Resource Locator section.

Quick Resource Locator for R630

