

# ARAME PENDANT SMALL - TRIO CLUSTER LARGE

## Product Specification

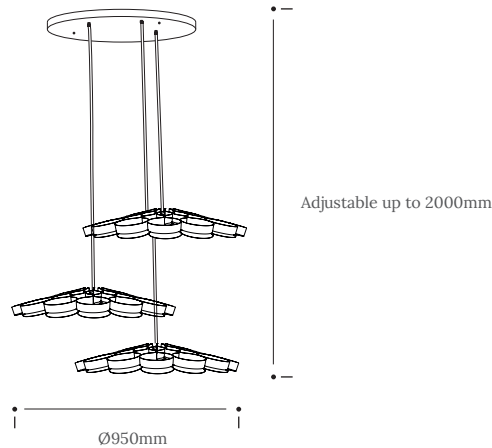



# Tom Raffield



Elemental, geometric, sequential. A trio of Small Arame Pendants pivot and descend from a single matte white or black ceiling kit to form a swooping spectacle. Switched on, each Arame Pendant produces an energising aura of soft ambient light. Switched off, the pendants become structural, architectural pieces of art that elevate your space and captivate any audience.

Available in a choice of ash or walnut wood and featuring two meters of high quality adjustable flex, the Arame Pendant Small - Trio Cluster Large can be modified to suit yours and your space's needs.

Our signature pendant lights, your way!

| Product Type :<br>Pendant Cluster                    | SKU   | Wood types   | Dimensions L x W x H (mm)   |                 | Weight (kg)                               |       |
|--|---|--|---|-----------------|---|-------|
|  |   |  | Unboxed   | Boxed           | Unboxed                                   | Boxed |
| Arame Pendant Small -<br>Trio Cluster Large<br>Black | TR-ARAM-P-A-SML-CLS-LRG-BLK   | Ash  | Ø950 x 2000   | 620 x 620 x 540 | 2.8                                       | 5.45  |
|  | TR-ARAM-P-W-SML-CLS-LRG-BLK   | Walnut   |   |                 |   |       |
| Arame Pendant Small -<br>Trio Cluster Large<br>White | TR-ARAM-P-A-SML-CLS-LRG-WHT   | Ash  |   |                 |   |       |
|  | TR-ARAM-P-W-SML-CLS-LRG-WHT   | Walnut   |   |                 |   |       |
| Materials  | Ash    | Walnut  | Other materials<br>Black or white powder coated metal ceiling plate  |                 |   |       |
| Finish   | Non-toxic, hard wearing water based varnish - satin   |  |   |                 |   |       |
| Ceiling kit option 1                                 | Black ceiling plate,<br>brass bulb holders and<br>cord grips   | Ceiling kit  | Flex  |                 | Reccomended light bulb<br><br>Max 25W LED |       |
| Ceiling kit option 2                                 |   | Ceiling plate: Ø400mm  | Flex colour: black fabric   |                 |   |       |
|  | White ceiling plate,<br>brushed steel bulb<br>holders and cord grips   | Ceiling kit  | Flex  |                 |   |       |
| Ceiling plate: Ø400mm                                |   | Flex colour: white fabric  |   |                 |   |       |
|  |   | E27 (240v)   | Flex length: 2m (Adjustable)  |                 |   |       |
| Care information                                     | Dusting your light regularly and with a light feather duster should keep your light looking clean, otherwise wipe with a damp cloth and remove any moisture with a dry cloth. Gentle furniture polishes can also be used. |  |   |                 |   |       |
| Additional information                               | <ul style="list-style-type: none"> <li>Suitable for use on 240v circuits.</li> <li>Installation instructions and fixings included.</li> <li>This product must be installed by a qualified electrician.</li> </ul>         |  |   |                 |   |       |

Tom Raffield Ltd, F3 Church View Business Park, Bickland Water Rd, Falmouth TR11 4FZ, UK  
tomraffield.com contact@tomraffield.com +44 (0) 1326 722725 #tomraffield @tomraffield

Due to the character of handcrafted natural products, all dimensions are approximate. Wood colour may slightly vary.  
All products, prices and leadtimes are correct at time of print and are subject to change without notice.