

Crossbar Substitute

Assembly instructions BH2001

- 1 Open Quick release clamp (FIGURE 1) then adjust crossbar substitute length to desired fit. (Distance between hooks: Max 32.25" / Min 23")

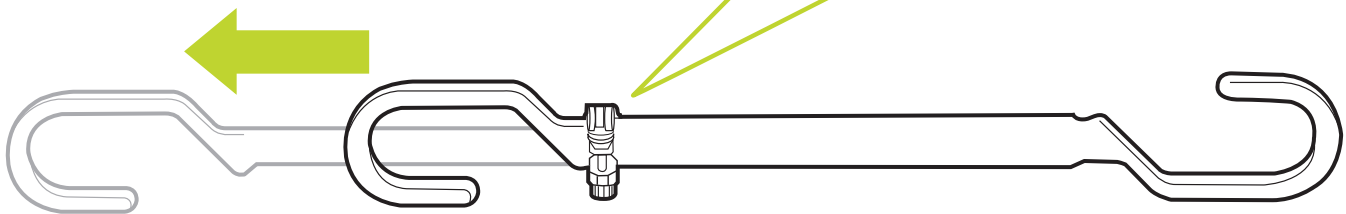
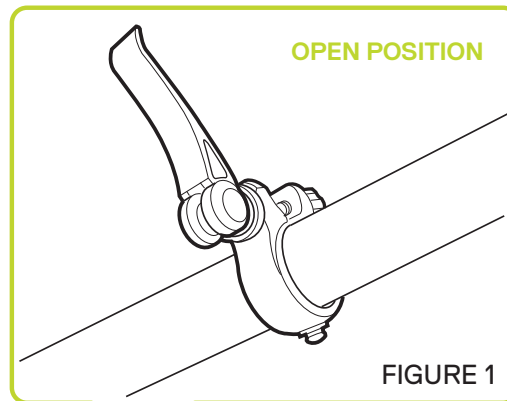

- 2 Place hooks around seat post and handlebar stem.

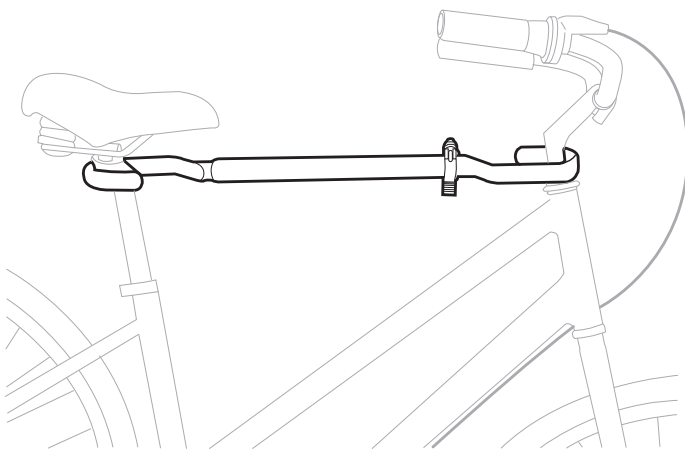

- 3 Close quick release clamp. Ensure locking lever is fully closed during transport.



IMPORTANT SAFETY NOTE

When mounting to rear bike rack, be sure to use the bike rack straps to secure the crossbar.

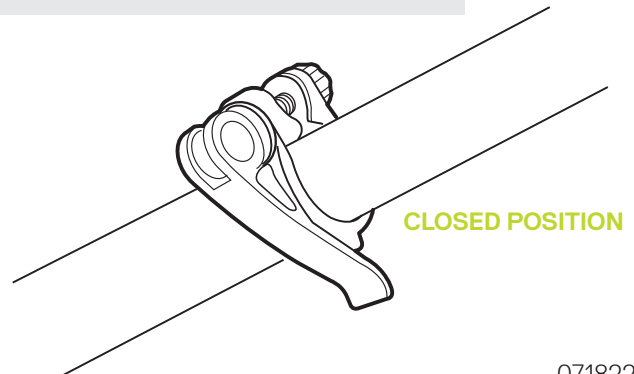

071822



WARNING

Do not exceed Max Load: 50 lb (22.7 kg)
Incorrect installation could result in an accident causing serious injury.
Failure to use strap may result in loss of bicycles.