

## My Hydrowave has no suction | Support

- Remove the Machine from the Storage Tray
- Power your machine off and unplug it
- Remove Dirty water tank by pressing down on the recessed button on the top of the tank

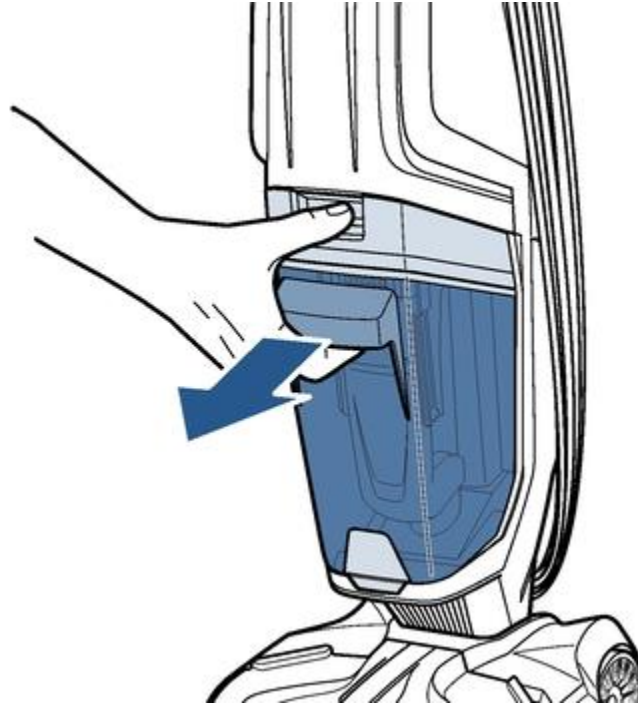

- With a cleaning mode selected and the machine powered on, feel for suction strength at the motor vents
  - if no suction visit a bissell authorized service center, or Contact Us
  - if suction is strong, continue troubleshooting
- Empty the dirty water tank by grabbing the top of the tank in the recessed are on each side of the Float Stack
  - Pour dirty water and debris out
  - Check the dirty water tank for any cracks or damage
  - if your dirty water tank is cracked or damaged, the dirty water tank should be replaced

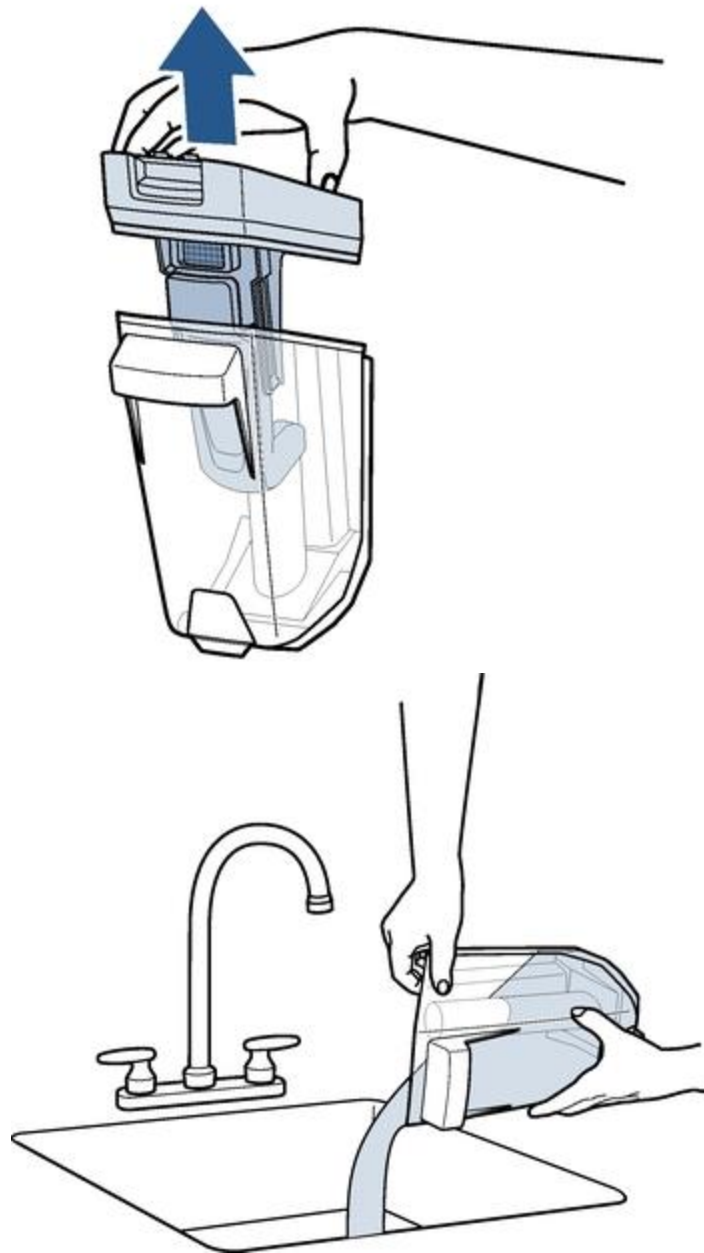

- Remove the filter from the float stack and clear it of debris

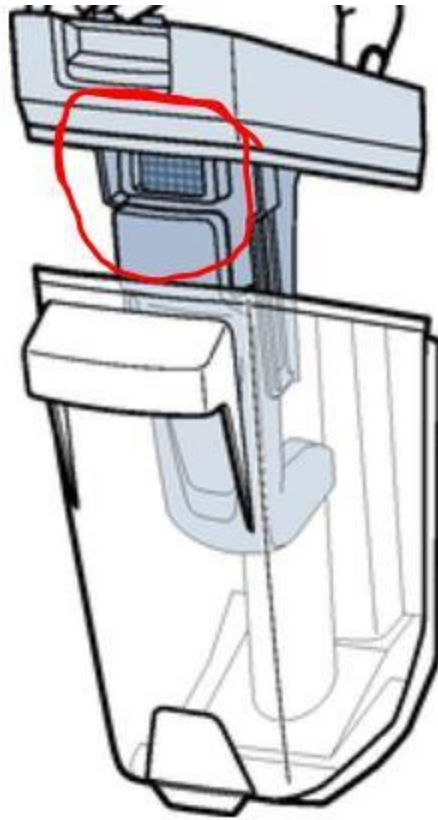

- Hand wash filter with warm water
- Rinse the float and clear any debris
- Make sure the float moves up and down smoothly



- Allow float, filter, and dirty tank to dry completely

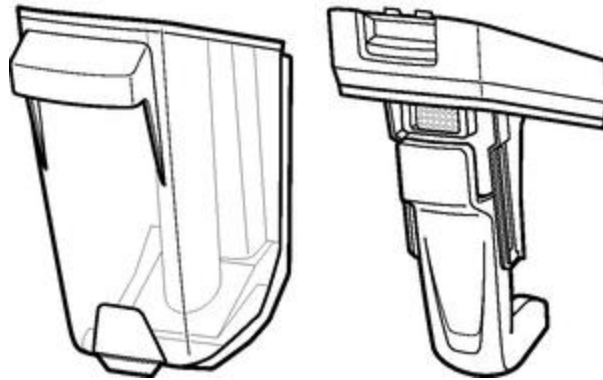

- Clear any clogs in the debris pathway and check for damage in the dirty tank pocket

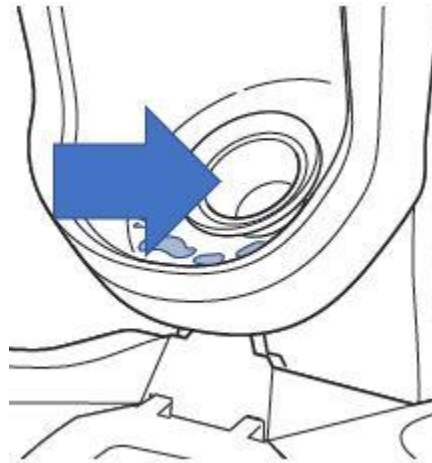

- Put the dirty water tank back in the machine
  - Angle the tank back into the body of the machine inserting the bottom first
  - Tilt the top of the tank toward the machine and push into place until you hear a click



- Remove the Nozzle from the foot of the machine by pulling up on both sides of the Nozzle
  - check for any cracks or damage to the Nozzle
  - if the Nozzle is cracked or damaged, a replacement should be ordered

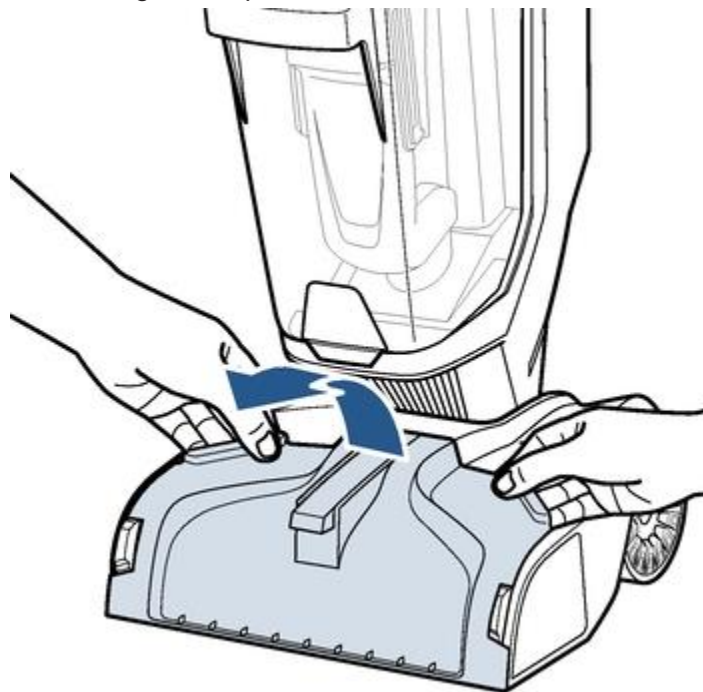

- Clean out the Nozzle using the Nozzle Clean Out Tool and rinse it with warm water

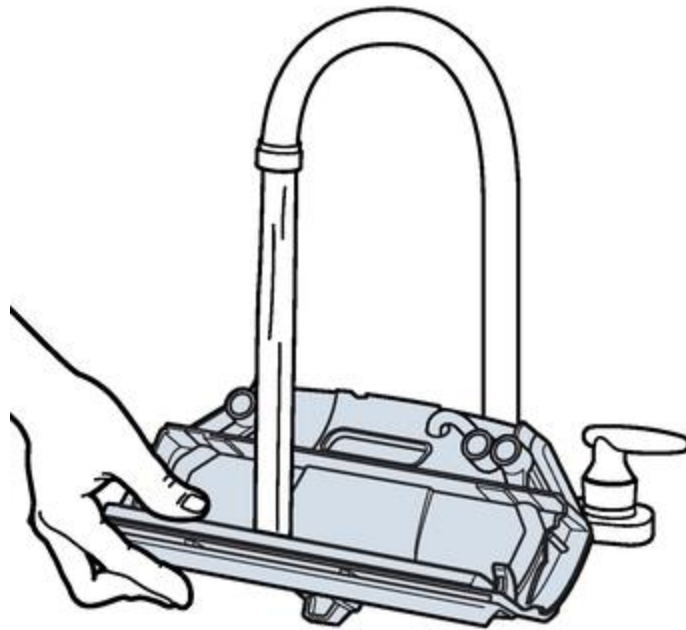
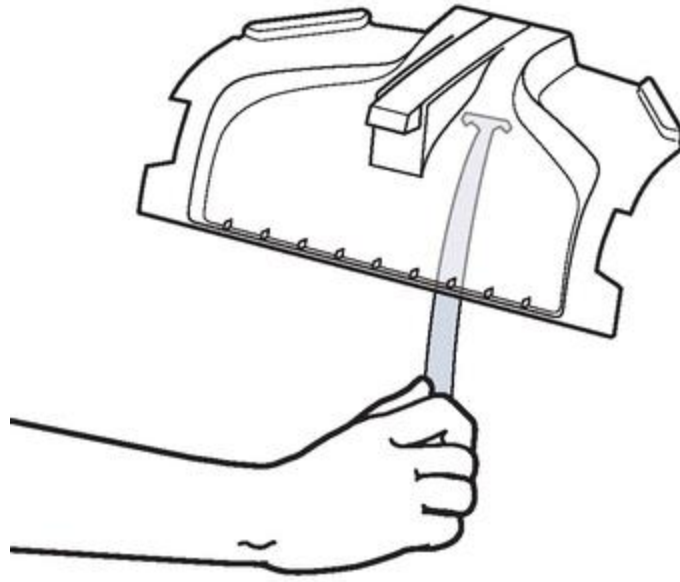

- Clear the suction gasket of any debris

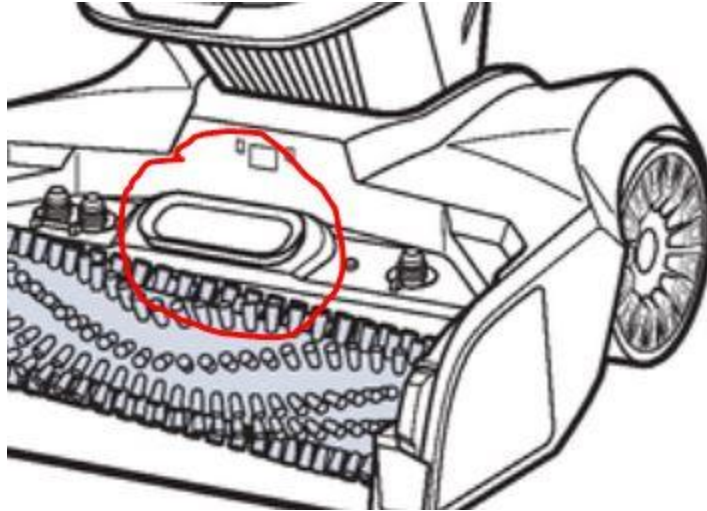

- Put Nozzle back on the machine
- Line up the tabs on the front edges of the foot and push the nozzle into place until it clicks

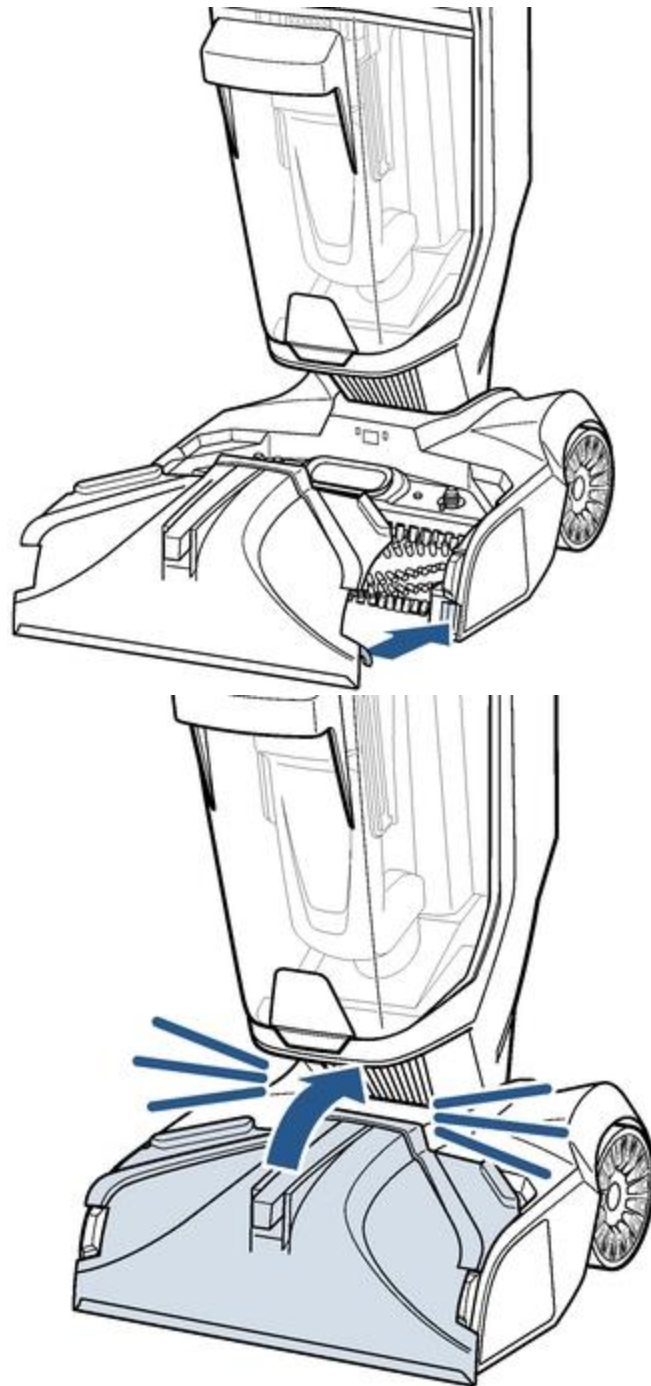

- Turn machine on and choose express clean, or deep clean mode to turn on the machine and test for suction
- If there is still no suction, [Contact Us](#)