

# FURRION

## 17" 2-IN-1 RANGE OVEN & WITH GRILL

+ DRAWER (OPTION)  
FS17'B4A / FSRL17CA

FS17B4A-BL &  
FDO12A-BL

FS17B4A-SB &  
FDO12NA-SB

FS17B4A-SS &  
FDO12A-SS

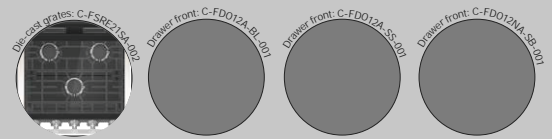

PROFILE OPTIONS



OVEN LIGHT BULB



LED KNOB



IMPROVED HEAT  
DISTRIBUTION



BROILER  
FUNCTION



x3  
GAS  
BURNERS



P-2  
IGNITER



GAS SAFETY  
AUTO CUT-OFF



TRIPLE LAYER  
GLASS DOOR



# FS17DB4A / FSRL17CA | 17" 2-IN-1 RANGE OVEN WITH DIE-CAST GRATES (DRAWER OPTION)

## Range Oven

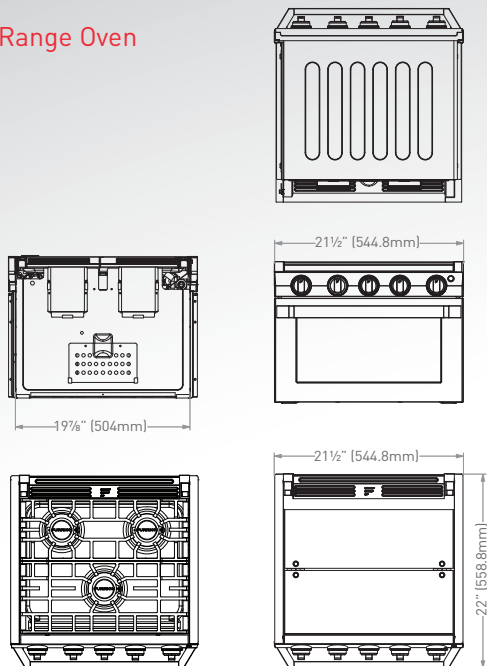

Top view without glass cover

## Drawer

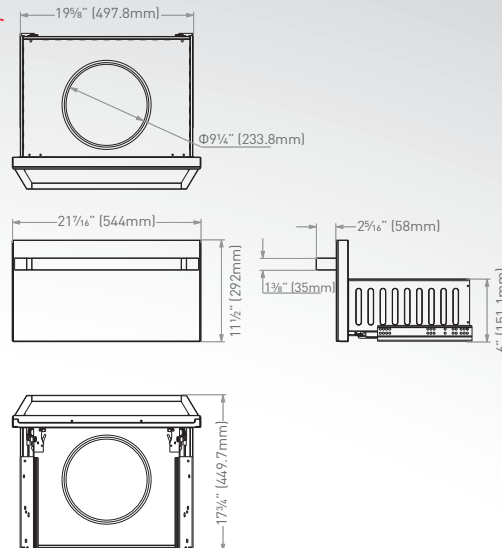

FS17DB4A-SS (Stainless steel) FSRL17CA-BL (Black, with black handle) FS17DB4A-BL (Black, with stainless steel handle)	17" 2-in-1 Range Oven
FDO12A-SS (Stainless steel) FDO12A-BL (Black, with black handle) FDO12NA-BL (Black, with stainless steel handle)	Drawer for 17"/21" 2-in-1 Range Oven

### Specifications

<b>Heat input</b>	
Left Cooktop Burner	6500 BTU
Front Cooktop Burner	8000 BTU
Right Cooktop Burner	6500 BTU
Oven Burner	7100 BTU
Die Cast Grates	✓
Piezo Igniter	✓
Cavity Light	12V
LED Manual Knob Gas	✓
Safety Cut-off Valve	✓
Triple Layer Glass Door	3-layer glass for the oven door
Glass Cover	2pcs slide form

### Dimensions

Range Oven (L x H x W)	21 1/2" x 16" x 22" (544.8 x 406.4 x 558.8mm)
Drawer (L x H x W)	21 7/8" x 11 1/2" x 17 3/4" (544 x 292 x 449.7mm)

### Packaging Information (Range Oven)

Packaging Type	Brown Box
Quantity Per Box (pcs)	1
Individual Packaging Dimensions (L x H x W)	24 13/16" x 19 15/16" x 25" (630 x 505 x 635mm)
Individual Packaging Gross Weight (kg/lbs)	29.2 / 64.4
Individual Packaging Net Weight (kg/lbs)	26.3 / 58.0

### Container Load Information

40'HQ Container Load (pcs)	286
----------------------------	-----

### Packaging Information (Drawer)

Packaging Type	Brown Box
Quantity Per Box (pcs)	1
Individual Packaging Dimensions (L x H x W)	22 5/8" x 13" x 18 11/16" (574 x 330 x 474mm)
Individual Packaging Gross Weight (kg/lbs)	12 / 26.5
Individual Packaging Net Weight (kg/lbs)	9 / 19.8

### Container Load Information

40' Container Load (pcs)	650
--------------------------	-----