

FHO24R91-SS

# 24" Chimney Range Hood

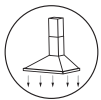

## Main Features



HIGH  
EXTRACTION RATE



ALUMINIUM  
FILTER



LED  
LIGHT



LCD  
DISPLAY

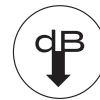

QUIET  
OPERATION



EASY  
INSTALLATION

**FURRION**

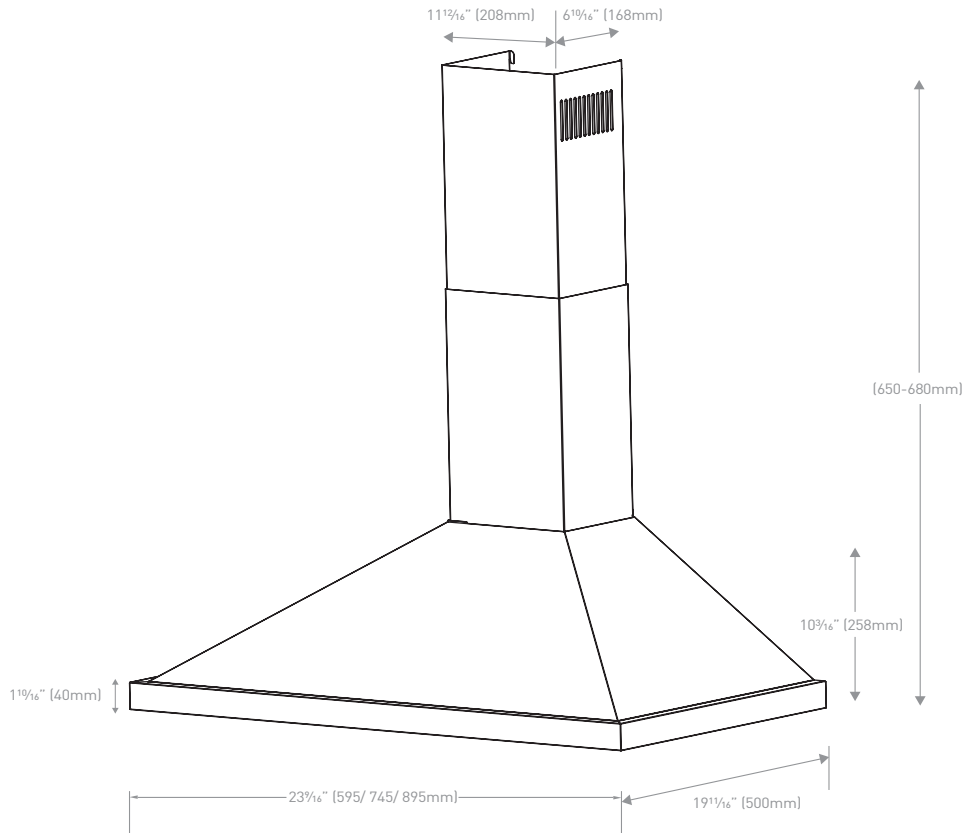

## Specifications

Rating Voltage	120V
Rating Power	190W (Including the LED) 2 x 1.5W (LED)
Available Colors	Stainless Steel
Collar Length	1"
Rough opening (rear/top)	82/11" x 63/5"
Internal Wire Temp Rating	105 °C
Noise	63dBA
Lumen (E middle)	136LX
Max Extraction Rate (m3/hr)	370CFM
Installation Type	Install on roof or wall
5 layers aluminum grease filter	✓

## Special Features

Button for Fan Power speed 1 / 2 / 3	✓
Button for LED Light ON/OFF	✓
CSA Certificate	✓
Ductless	✓
Delay off	1 & 5 minutes

## Dimensions

Product Size (W x H x D)	24" x 38 1/2" x 19 2/3" (595 x 980 x 500mm)
--------------------------	--

## Packaging Information

Packaging Type	Master Carton Box
Quantity Per Box (pcs)	1
Individual Packaging Dimensions (W x H x D)	25 1/8" x 22" x 12 2/8" (640 x 560 x 315mm)
Individual Packaging Gross Weight (kg/lbs)	12.5/27.5
Individual Packaging Net Weight (kg/lbs)	10.5/23.1

## Container Load Information

40'HQ Container Load (pcs)	405
----------------------------	-----

