



Hewlett Packard
Enterprise

HPE ProLiant DL560 Gen9 Server

Maintenance and Service Guide

Abstract

This guide describes identification and maintenance procedures, diagnostic tools, specifications, and requirements for hardware components and software. This guide is for an experienced service technician. Hewlett Packard Enterprise assumes you are qualified in the servicing of computer equipment, trained in recognizing hazards in products, and are familiar with weight and stability precautions.

Part Number: 796439-003
June 2020
Edition: 3

© Copyright 2015, 2020 Hewlett Packard Enterprise Development LP

The information contained herein is subject to change without notice. The only warranties for Hewlett Packard Enterprise products and services are set forth in the express warranty statements accompanying such products and services. Nothing herein should be construed as constituting an additional warranty. Hewlett Packard Enterprise shall not be liable for technical or editorial errors or omissions contained herein.

Links to third-party websites take you outside the Hewlett Packard Enterprise website. Hewlett Packard Enterprise has no control over and is not responsible for information outside the Hewlett Packard Enterprise website.

Microsoft®, Windows®, and Windows Server® are either registered trademarks or trademarks of Microsoft Corporation in the United States and/or other countries. Intel®, Pentium®, and Itanium® are trademarks of Intel Corporation in the U.S. and other countries. UNIX® is a registered trademark of The Open Group.

Contents

Customer self repair.....	5
Parts only warranty service	5
Illustrated parts catalog.....	15
Mechanical components.....	15
System components.....	18
Removal and replacement procedures	25
Required tools	25
Safety considerations	25
Preventing electrostatic discharge.....	25
Symbols on equipment.....	25
Server warnings and cautions	26
Preparation procedures.....	26
Extend the server from the rack	27
Power down the server.....	28
Remove the server from the rack	28
Access the product rear panel.....	30
Access the Systems Insight Display option	30
Access panel	31
Air baffle	32
Mezzanine tray option	33
Primary 3-slot PCI riser cage	33
PCIe riser board	34
Remove the secondary PCI riser cage.....	35
Systems Insight Display	36
Hot-plug fan.....	38
Removing a hot-plug fan	38
Fan cage	39
Drive blank	40
Hot-plug drive.....	40
8SFF front drive cage.....	41
Drive cage backplane.....	42
2SFF drive cage backplane.....	43
Universal media bay.....	44
Universal media bay with two-bay SFF drive cage	46
Optical disk drive option	53
FlexibleLOM	54
Ear bezels	55
Location Discovery Services Ear option.....	56
Expansion slot blanks.....	59
Expansion boards.....	60
Half-length expansion board	60
SAS expander card option	61
AROC controller	66
Power supply backplane	67
DIMMs	68
HPE Smart Storage Battery	69
Heatsink	70
Processor	72
Power supply blank	76
AC power supply	76
System board	77
System battery	83
HP Trusted Platform Module.....	84

Troubleshooting	85
Troubleshooting resources	85
Diagnostic tools	86
Product QuickSpecs	86
HPE iLO	86
Active Health System	86
HPE ProLiant Pre-boot Health Summary	87
Integrated Management Log	87
HPE UEFI System Utilities	87
Using UEFI System Utilities	88
Flexible boot control	88
Restoring and customizing configuration settings	89
Secure Boot configuration	89
Embedded UEFI shell	89
Embedded Diagnostics option	90
iLO RESTful API support for UEFI	90
Re-entering the server serial number and product ID	90
HPE ProLiant Pre-boot Health Summary	90
HPE Insight Diagnostics	91
HPE Insight Diagnostics survey functionality	91
USB support	91
External USB functionality	92
Internal USB functionality	92
HPE Smart Storage Administrator	92
Automatic Server Recovery	93
Component identification	94
Front panel components	94
Front panel LEDs	94
Power fault LEDs	95
Systems Insight Display option LEDs	96
Systems Insight Display LED combinations	96
Rear panel components	98
Non-hot-plug PCIe riser board slot definitions	98
System board components	99
System maintenance switch	100
NMI functionality	101
DIMM slot locations	102
Hot-plug drive bay numbering	102
Hot-plug drive LED definitions	103
Hot-plug fans	103
Storage and expansion diagram	105
Cabling	106
Mini-SAS cable option	106
SAS drive cabling	106
SAS expander card option cabling	107
Specifications	108
Environmental specifications	108
Mechanical specifications	108
Power supply specifications	108
HPE 1500 W Common Slot Platinum Plus Hot-Plug Power Supply (94% efficiency)	109
HPE 1200 W Common Slot Platinum Plus Hot-Plug Power Supply (94% efficiency)	109
HPE 1500 W Common Slot -48 VDC Hot-plug Power Supply	110
Hot-plug power supply calculations	111
Acronyms and abbreviations	112
Documentation feedback	114
Index	115

Customer self repair

Hewlett Packard Enterprise products are designed with many Customer Self Repair (CSR) parts to minimize repair time and allow for greater flexibility in performing defective parts replacement. If during the diagnosis period Hewlett Packard Enterprise (or Hewlett Packard Enterprise service providers or service partners) identifies that the repair can be accomplished by the use of a CSR part, Hewlett Packard Enterprise will ship that part directly to you for replacement. There are two categories of CSR parts:

- **Mandatory**—Parts for which customer self repair is mandatory. If you request Hewlett Packard Enterprise to replace these parts, you will be charged for the travel and labor costs of this service.
- **Optional**—Parts for which customer self repair is optional. These parts are also designed for customer self repair. If, however, you require that Hewlett Packard Enterprise replace them for you, there may or may not be additional charges, depending on the type of warranty service designated for your product.

NOTE: Some Hewlett Packard Enterprise parts are not designed for customer self repair. In order to satisfy the customer warranty, Hewlett Packard Enterprise requires that an authorized service provider replace the part. These parts are identified as "No" in the Illustrated Parts Catalog.

Based on availability and where geography permits, CSR parts will be shipped for next business day delivery. Same day or four-hour delivery may be offered at an additional charge where geography permits. If assistance is required, you can call the Hewlett Packard Enterprise Support Center and a technician will help you over the telephone. Hewlett Packard Enterprise specifies in the materials shipped with a replacement CSR part whether a defective part must be returned to Hewlett Packard Enterprise. In cases where it is required to return the defective part to Hewlett Packard Enterprise, you must ship the defective part back to Hewlett Packard Enterprise within a defined period of time, normally five (5) business days. The defective part must be returned with the associated documentation in the provided shipping material. Failure to return the defective part may result in Hewlett Packard Enterprise billing you for the replacement. With a customer self repair, Hewlett Packard Enterprise will pay all shipping and part return costs and determine the courier/carrier to be used.

For more information about the Hewlett Packard Enterprise CSR program, contact your local service provider. For the North American program, go to the Hewlett Packard Enterprise CSR website (<http://www.hpe.com/support/selfrepair>).

Parts only warranty service

Your Hewlett Packard Enterprise Limited Warranty may include a parts only warranty service. Under the terms of parts only warranty service, Hewlett Packard Enterprise will provide replacement parts free of charge.

For parts only warranty service, CSR part replacement is mandatory. If you request Hewlett Packard Enterprise to replace these parts, you will be charged for the travel and labor costs of this service.

Réparation par le client (CSR)

Les produits Hewlett Packard Enterprise comportent de nombreuses pièces CSR (Customer Self Repair = réparation par le client) afin de minimiser les délais de réparation et faciliter le remplacement des pièces défectueuses. Si pendant la période de diagnostic, Hewlett Packard Enterprise (ou ses partenaires ou mainteneurs agréés) détermine que la réparation peut être effectuée à l'aide d'une pièce CSR, Hewlett Packard Enterprise vous l'envoie directement. Il existe deux catégories de pièces CSR :

- **Obligatoire**—Pièces pour lesquelles la réparation par le client est obligatoire. Si vous demandez à Hewlett Packard Enterprise de remplacer ces pièces, les coûts de déplacement et main d'œuvre du service vous seront facturés.
- **Facultatif**—Pièces pour lesquelles la réparation par le client est facultative. Ces pièces sont également conçues pour permettre au client d'effectuer lui-même la réparation. Toutefois, si vous demandez à Hewlett Packard Enterprise de remplacer ces pièces, l'intervention peut ou non vous être facturée, selon le type de garantie applicable à votre produit.

REMARQUE: Certaines pièces Hewlett Packard Enterprise ne sont pas conçues pour permettre au client d'effectuer lui-même la réparation. Pour que la garantie puisse s'appliquer, Hewlett Packard Enterprise exige que le remplacement de la pièce soit effectué par un Mainteneur Agréé. Ces pièces sont identifiées par la mention "Non" dans le Catalogue illustré.

Les pièces CSR sont livrées le jour ouvré suivant, dans la limite des stocks disponibles et selon votre situation géographique. Si votre situation géographique le permet et que vous demandez une livraison le jour même ou dans les 4 heures, celle-ci vous sera facturée. Pour toute assistance, appelez le Centre d'assistance Hewlett Packard Enterprise pour qu'un technicien vous aide au téléphone. Dans les documents envoyés avec la pièce de rechange CSR, Hewlett Packard Enterprise précise s'il est nécessaire de lui retourner la pièce défectueuse. Si c'est le cas, vous devez le faire dans le délai indiqué, généralement cinq (5) jours ouvrés. La pièce et sa documentation doivent être retournées dans l'emballage fourni. Si vous ne retournez pas la pièce défectueuse, Hewlett Packard Enterprise se réserve le droit de vous facturer les coûts de remplacement. Dans le cas d'une pièce CSR, Hewlett Packard Enterprise supporte l'ensemble des frais d'expédition et de retour, et détermine la société de courses ou le transporteur à utiliser.

Pour plus d'informations sur le programme CSR de Hewlett Packard Enterprise, contactez votre Mainteneur Agréé local. Pour plus d'informations sur ce programme en Amérique du Nord, consultez le site Web Hewlett Packard Enterprise (<http://www.hpe.com/support/selfrepair>).

Service de garantie "pièces seules"

Votre garantie limitée Hewlett Packard Enterprise peut inclure un service de garantie "pièces seules". Dans ce cas, les pièces de rechange fournies par Hewlett Packard Enterprise ne sont pas facturées.

Dans le cadre de ce service, la réparation des pièces CSR par le client est obligatoire. Si vous demandez à Hewlett Packard Enterprise de remplacer ces pièces, les coûts de déplacement et main d'œuvre du service vous seront facturés.

Riparazione da parte del cliente

Per abbreviare i tempi di riparazione e garantire una maggiore flessibilità nella sostituzione di parti difettose, i prodotti Hewlett Packard Enterprise sono realizzati con numerosi componenti che possono essere riparati direttamente dal cliente (CSR, Customer Self Repair). Se in fase di diagnostica Hewlett Packard Enterprise (o un centro di servizi o di assistenza Hewlett Packard Enterprise) identifica il guasto come riparabile mediante un ricambio CSR, Hewlett Packard Enterprise lo spedisce direttamente al cliente per la sostituzione. Vi sono due categorie di parti CSR:

- **Obbligatorie**—Parti che devono essere necessariamente riparate dal cliente. Se il cliente ne affida la riparazione ad Hewlett Packard Enterprise, deve sostenere le spese di spedizione e di manodopera per il servizio.
- **Opzionali**—Parti la cui riparazione da parte del cliente è facoltativa. Si tratta comunque di componenti progettati per questo scopo. Se tuttavia il cliente ne richiede la sostituzione ad Hewlett Packard Enterprise, potrebbe dover sostenere spese aggiuntive a seconda del tipo di garanzia previsto per il prodotto.

NOTA: alcuni componenti Hewlett Packard Enterprise non sono progettati per la riparazione da parte del cliente. Per rispettare la garanzia, Hewlett Packard Enterprise richiede che queste parti siano sostituite da un centro di assistenza autorizzato. Tali parti sono identificate da un "No" nel Catalogo illustrato dei componenti.

In base alla disponibilità e alla località geografica, le parti CSR vengono spedite con consegna entro il giorno lavorativo seguente. La consegna nel giorno stesso o entro quattro ore è offerta con un supplemento di costo solo in alcune zone. In caso di necessità si può richiedere l'assistenza telefonica di un addetto del centro di supporto tecnico Hewlett Packard Enterprise. Nel materiale fornito con una parte di ricambio CSR, Hewlett Packard Enterprise specifica se il cliente deve restituire dei componenti. Qualora sia richiesta la resa ad Hewlett Packard Enterprise del componente difettoso, lo si deve spedire ad Hewlett Packard Enterprise entro un determinato periodo di tempo, generalmente cinque (5) giorni lavorativi. Il componente difettoso deve essere restituito con la documentazione associata nell'imballo di spedizione fornito. La mancata restituzione del componente può comportare la fatturazione del ricambio da parte di Hewlett Packard Enterprise. Nel caso di riparazione da parte del cliente, Hewlett Packard Enterprise sostiene tutte le spese di spedizione e resa e sceglie il corriere/vettore da utilizzare.

Per ulteriori informazioni sul programma CSR di Hewlett Packard Enterprise, contattare il centro di assistenza di zona. Per il programma in Nord America fare riferimento al sito Web (<http://www.hpe.com/support/selfrepair>).

Servizio di garanzia per i soli componenti

La garanzia limitata Hewlett Packard Enterprise può includere un servizio di garanzia per i soli componenti. Nei termini di garanzia del servizio per i soli componenti, Hewlett Packard Enterprise fornirà gratuitamente le parti di ricambio.

Per il servizio di garanzia per i soli componenti è obbligatoria la formula CSR che prevede la riparazione da parte del cliente. Se il cliente invece richiede la sostituzione ad Hewlett Packard Enterprise dovrà sostenere le spese di spedizione e di manodopera per il servizio.

Customer Self Repair

Hewlett Packard Enterprise Produkte enthalten viele CSR-Teile (Customer Self Repair), um Reparaturzeiten zu minimieren und höhere Flexibilität beim Austausch defekter Bauteile zu ermöglichen. Wenn Hewlett Packard Enterprise (oder ein Hewlett Packard Enterprise Servicepartner) bei der Diagnose feststellt, dass das Produkt mithilfe eines CSR-Teils repariert werden kann, sendet Ihnen Hewlett Packard Enterprise dieses Bauteil zum Austausch direkt zu. CSR-Teile werden in zwei Kategorien unterteilt:

- **Zwingend**—Teile, für die das Customer Self Repair-Verfahren zwingend vorgegeben ist. Wenn Sie den Austausch dieser Teile von Hewlett Packard Enterprise vornehmen lassen, werden Ihnen die Anfahrt- und Arbeitskosten für diesen Service berechnet.
- **Optional**—Teile, für die das Customer Self Repair-Verfahren optional ist. Diese Teile sind auch für Customer Self Repair ausgelegt. Wenn Sie jedoch den Austausch dieser Teile von Hewlett Packard Enterprise vornehmen lassen möchten, können bei diesem Service je nach den für Ihr Produkt vorgesehenen Garantiebedingungen zusätzliche Kosten anfallen.

HINWEIS: Einige Hewlett Packard Enterprise Teile sind nicht für Customer Self Repair ausgelegt. Um den Garantieanspruch des Kunden zu erfüllen, muss das Teil von einem Hewlett Packard Enterprise Servicepartner ersetzt werden. Im illustrierten Teilekatalog sind diese Teile mit „No“ bzw. „Nein“ gekennzeichnet.

CSR-Teile werden abhängig von der Verfügbarkeit und vom Lieferziel am folgenden Geschäftstag geliefert. Für bestimmte Standorte ist eine Lieferung am selben Tag oder innerhalb von vier Stunden gegen einen Aufpreis verfügbar. Wenn Sie Hilfe benötigen, können Sie das Hewlett Packard Enterprise

Support Center anrufen und sich von einem Mitarbeiter per Telefon helfen lassen. Den Materialien von Hewlett Packard Enterprise, die mit einem CSR-Ersatzteil geliefert werden, können Sie entnehmen, ob das defekte Teil an Hewlett Packard Enterprise zurückgeschickt werden muss. Wenn es erforderlich ist, das defekte Teil an Hewlett Packard Enterprise zurückzuschicken, müssen Sie dies innerhalb eines vorgegebenen Zeitraums tun, in der Regel innerhalb von fünf (5) Geschäftstagen. Das defekte Teil muss mit der zugehörigen Dokumentation in der Verpackung zurückgeschickt werden, die im Lieferumfang enthalten ist. Wenn Sie das defekte Teil nicht zurückschicken, kann Hewlett Packard Enterprise Ihnen das Ersatzteil in Rechnung stellen. Im Falle von Customer Self Repair kommt Hewlett Packard Enterprise für alle Kosten für die Lieferung und Rücksendung auf und bestimmt den Kurier-/Frachtdienst.

Weitere Informationen über das Hewlett Packard Enterprise Customer Self Repair Programm erhalten Sie von Ihrem Servicepartner vor Ort. Informationen über das CSR-Programm in Nordamerika finden Sie auf der Hewlett Packard Enterprise Website unter (<http://www.hpe.com/support/selfrepair>).

Parts-only Warranty Service (Garantieservice ausschließlich für Teile)

Ihre Hewlett Packard Enterprise Garantie umfasst möglicherweise einen Parts-only Warranty Service (Garantieservice ausschließlich für Teile). Gemäß den Bestimmungen des Parts-only Warranty Service stellt Hewlett Packard Enterprise Ersatzteile kostenlos zur Verfügung.

Für den Parts-only Warranty Service ist das CSR-Verfahren zwingend vorgegeben. Wenn Sie den Austausch dieser Teile von Hewlett Packard Enterprise vornehmen lassen, werden Ihnen die Anfahrt- und Arbeitskosten für diesen Service berechnet.

Reparaciones del propio cliente

Los productos de Hewlett Packard Enterprise incluyen muchos componentes que el propio usuario puede reemplazar (Customer Self Repair, CSR) para minimizar el tiempo de reparación y ofrecer una mayor flexibilidad a la hora de realizar sustituciones de componentes defectuosos. Si, durante la fase de diagnóstico, Hewlett Packard Enterprise (o los proveedores o socios de servicio de Hewlett Packard Enterprise) identifica que una reparación puede llevarse a cabo mediante el uso de un componente CSR, Hewlett Packard Enterprise le enviará dicho componente directamente para que realice su sustitución. Los componentes CSR se clasifican en dos categorías:

- **Obligatorio**—Componentes cuya reparación por parte del usuario es obligatoria. Si solicita a Hewlett Packard Enterprise que realice la sustitución de estos componentes, tendrá que hacerse cargo de los gastos de desplazamiento y de mano de obra de dicho servicio.
- **Opcional**—Componentes cuya reparación por parte del usuario es opcional. Estos componentes también están diseñados para que puedan ser reparados por el usuario. Sin embargo, si precisa que Hewlett Packard Enterprise realice su sustitución, puede o no conllevar costes adicionales, dependiendo del tipo de servicio de garantía correspondiente al producto.

NOTA: Algunos componentes de Hewlett Packard Enterprise no están diseñados para que puedan ser reparados por el usuario. Para que el usuario haga valer su garantía, Hewlett Packard Enterprise pone como condición que un proveedor de servicios autorizado realice la sustitución de estos componentes. Dichos componentes se identifican con la palabra "No" en el catálogo ilustrado de componentes.

Según la disponibilidad y la situación geográfica, los componentes CSR se enviarán para que lleguen a su destino al siguiente día laborable. Si la situación geográfica lo permite, se puede solicitar la entrega en el mismo día o en cuatro horas con un coste adicional. Si precisa asistencia técnica, puede llamar al Centro de asistencia técnica de Hewlett Packard Enterprise y recibirá ayuda telefónica por parte de un técnico. Con el envío de materiales para la sustitución de componentes CSR, Hewlett Packard Enterprise especificará si los componentes defectuosos deberán devolverse a Hewlett Packard Enterprise. En aquellos casos en los que sea necesario devolver algún componente a Hewlett Packard Enterprise,

deberá hacerlo en el periodo de tiempo especificado, normalmente cinco días laborables. Los componentes defectuosos deberán devolverse con toda la documentación relacionada y con el embalaje de envío. Si no enviara el componente defectuoso requerido, Hewlett Packard Enterprise podrá cobrarle por el de sustitución. En el caso de todas sustituciones que lleve a cabo el cliente, Hewlett Packard Enterprise se hará cargo de todos los gastos de envío y devolución de componentes y escogerá la empresa de transporte que se utilice para dicho servicio.

Para obtener más información acerca del programa de Reparaciones del propio cliente de Hewlett Packard Enterprise, póngase en contacto con su proveedor de servicios local. Si está interesado en el programa para Norteamérica, visite la página web de Hewlett Packard Enterprise CSR (<http://www.hpe.com/support/selfrepair>).

Servicio de garantía exclusivo de componentes

La garantía limitada de Hewlett Packard Enterprise puede que incluya un servicio de garantía exclusivo de componentes. Según las condiciones de este servicio exclusivo de componentes, Hewlett Packard Enterprise le facilitará los componentes de repuesto sin cargo adicional alguno.

Para este servicio de garantía exclusivo de componentes, es obligatoria la sustitución de componentes por parte del usuario (CSR). Si solicita a Hewlett Packard Enterprise que realice la sustitución de estos componentes, tendrá que hacerse cargo de los gastos de desplazamiento y de mano de obra de dicho servicio.

Customer Self Repair

Veel onderdelen in Hewlett Packard Enterprise producten zijn door de klant zelf te repareren, waardoor de reparatieduur tot een minimum beperkt kan blijven en de flexibiliteit in het vervangen van defecte onderdelen groter is. Deze onderdelen worden CSR-onderdelen (Customer Self Repair) genoemd. Als Hewlett Packard Enterprise (of een Hewlett Packard Enterprise Service Partner) bij de diagnose vaststelt dat de reparatie kan worden uitgevoerd met een CSR-onderdeel, verzendt Hewlett Packard Enterprise dat onderdeel rechtstreeks naar u, zodat u het defecte onderdeel daarmee kunt vervangen. Er zijn twee categorieën CSR-onderdelen:

- **Verplicht**—Onderdelen waarvoor reparatie door de klant verplicht is. Als u Hewlett Packard Enterprise verzoekt deze onderdelen voor u te vervangen, worden u voor deze service reiskosten en arbeidsloon in rekening gebracht.
- **Optioneel**—Onderdelen waarvoor reparatie door de klant optioneel is. Ook deze onderdelen zijn ontworpen voor reparatie door de klant. Als u echter Hewlett Packard Enterprise verzoekt deze onderdelen voor u te vervangen, kunnen daarvoor extra kosten in rekening worden gebracht, afhankelijk van het type garantieservice voor het product.

OPMERKING: Sommige Hewlett Packard Enterprise onderdelen zijn niet ontwikkeld voor reparatie door de klant. In verband met de garanti voorwaarden moet het onderdeel door een geautoriseerde Service Partner worden vervangen. Deze onderdelen worden in de geïllustreerde onderdelencatalogus aangemerkt met "Nee".

Afhankelijk van de leverbaarheid en de locatie worden CSR-onderdelen verzonden voor levering op de eerstvolgende werkdag. Levering op dezelfde dag of binnen vier uur kan tegen meerkosten worden aangeboden, indien dit mogelijk is gezien de locatie. Indien assistentie is gewenst, belt u het Hewlett Packard Enterprise Support Center om via de telefoon ondersteuning van een technicus te ontvangen. Hewlett Packard Enterprise vermeldt in de documentatie bij het vervangende CSR-onderdeel of het defecte onderdeel aan Hewlett Packard Enterprise moet worden geretourneerd. Als het defecte onderdeel aan Hewlett Packard Enterprise moet worden teruggezonden, moet u het defecte onderdeel binnen een bepaalde periode, gewoonlijk vijf (5) werkdagen, retourneren aan Hewlett Packard Enterprise. Het defecte onderdeel moet met de bijbehorende documentatie worden geretourneerd in het meegeleverde verpakkingsmateriaal. Als u het defecte onderdeel niet terugzendt, kan Hewlett Packard

Enterprise u voor het vervangende onderdeel kosten in rekening brengen. Bij reparatie door de klant betaalt Hewlett Packard Enterprise alle verzendkosten voor het vervangende en geretourneerde onderdeel en kiest Hewlett Packard Enterprise zelf welke koerier/transportonderneming hiervoor wordt gebruikt.

Neem contact op met een Service Partner voor meer informatie over het Customer Self Repair programma van Hewlett Packard Enterprise. Informatie over Service Partners vindt u op de Hewlett Packard Enterprise website (<http://www.hpe.com/support/selfrepair>).

Garantieservice "Parts Only"

Het is mogelijk dat de Hewlett Packard Enterprise garantie alleen de garantieservice "Parts Only" omvat. Volgens de bepalingen van de Parts Only garantieservice zal Hewlett Packard Enterprise kosteloos vervangende onderdelen ter beschikking stellen.

Voor de Parts Only garantieservice is vervanging door CSR-onderdelen verplicht. Als u Hewlett Packard Enterprise verzoekt deze onderdelen voor u te vervangen, worden u voor deze service reiskosten en arbeidsloon in rekening gebracht

Reparo feito pelo cliente

Os produtos da Hewlett Packard Enterprise são projetados com muitas peças para reparo feito pelo cliente (CSR) de modo a minimizar o tempo de reparo e permitir maior flexibilidade na substituição de peças com defeito. Se, durante o período de diagnóstico, a Hewlett Packard Enterprise (ou fornecedores/parceiros da Hewlett Packard Enterprise) concluir que o reparo pode ser efetuado pelo uso de uma peça CSR, a Hewlett Packard Enterprise enviará a peça diretamente ao cliente. Há duas categorias de peças CSR:

- **Obrigatória**—Peças cujo reparo feito pelo cliente é obrigatório. Se desejar que a Hewlett Packard Enterprise substitua essas peças, serão cobradas as despesas de transporte e mão-de-obra do serviço.
- **Opcional**—Peças cujo reparo feito pelo cliente é opcional. Essas peças também são projetadas para o reparo feito pelo cliente. No entanto, se desejar que a Hewlett Packard Enterprise as substitua, pode haver ou não a cobrança de taxa adicional, dependendo do tipo de serviço de garantia destinado ao produto.

OBSERVAÇÃO: Algumas peças da Hewlett Packard Enterprise não são projetadas para o reparo feito pelo cliente. A fim de cumprir a garantia do cliente, a Hewlett Packard Enterprise exige que um técnico autorizado substitua a peça. Essas peças estão identificadas com a marca "No" (Não), no catálogo de peças ilustrado.

Conforme a disponibilidade e o local geográfico, as peças CSR serão enviadas no primeiro dia útil após o pedido. Onde as condições geográficas permitirem, a entrega no mesmo dia ou em quatro horas pode ser feita mediante uma taxa adicional. Se precisar de auxílio, entre em contato com o Centro de suporte técnico da Hewlett Packard Enterprise para que um técnico o ajude por telefone. A Hewlett Packard Enterprise especifica nos materiais fornecidos com a peça CSR de reposição se a peça com defeito deve ser devolvida à Hewlett Packard Enterprise. Nos casos em que isso for necessário, é preciso enviar a peça com defeito à Hewlett Packard Enterprise, você deverá enviar a peça com defeito de volta para a Hewlett Packard Enterprise dentro do período de tempo definido, normalmente em 5 (cinco) dias úteis. A peça com defeito deve ser enviada com a documentação correspondente no material de transporte fornecido. Caso não o faça, a Hewlett Packard Enterprise poderá cobrar a reposição. Para as peças de reparo feito pelo cliente, a Hewlett Packard Enterprise paga todas as despesas de transporte e de devolução da peça e determina a transportadora/serviço postal a ser utilizado.

Para obter mais informações sobre o programa de reparo feito pelo cliente da Hewlett Packard Enterprise, entre em contato com o fornecedor de serviços local. Para o programa norte-americano, visite o site da Hewlett Packard Enterprise (<http://www.hpe.com/support/selfrepair>).

Serviço de garantia apenas para peças

A garantia limitada da Hewlett Packard Enterprise pode incluir um serviço de garantia apenas para peças. Segundo os termos do serviço de garantia apenas para peças, a Hewlett Packard Enterprise fornece as peças de reposição sem cobrar nenhuma taxa.

No caso desse serviço, a substituição de peças CSR é obrigatória. Se desejar que a Hewlett Packard Enterprise substitua essas peças, serão cobradas as despesas de transporte e mão-de-obra do serviço.

カスタマーセルフリペア

修理時間を短縮し、故障部品の交換における高い柔軟性を確保するために、Hewlett Packard Enterprise製品には多数のカスタマーセルフリペア（CSR）部品があります。診断の際に、CSR部品を使用すれば修理ができるとHewlett Packard Enterprise（Hewlett Packard EnterpriseまたはHewlett Packard Enterprise正規保守代理店）が判断した場合、Hewlett Packard Enterpriseはその部品を直接、お客様に発送し、お客様に交換していただきます。CSR部品には以下の2種類があります。

- **必須** - カスタマーセルフリペアが必須の部品。当該部品について、もしもお客様がHewlett Packard Enterpriseに交換作業を依頼される場合には、その修理サービスに関する交通費および人件費がお客様に請求されます。
- **任意** - カスタマーセルフリペアが任意である部品。この部品もカスタマーセルフリペア用です。当該部品について、もしもお客様がHewlett Packard Enterpriseに交換作業を依頼される場合には、お買い上げの製品に適用される保証サービス内容の範囲内においては、別途費用を負担していただくことなく保証サービスを受けることができます。

注：Hewlett Packard Enterprise製品の一部の部品は、カスタマーセルフリペアの対象外です。製品の保証を継続するためには、Hewlett Packard EnterpriseまたはHewlett Packard Enterprise正規保守代理店による交換作業が必須となります。部品カタログには、当該部品がカスタマーセルフリペア除外品である旨が記載されています。

部品供給が可能な場合、地域によっては、CSR部品を翌営業日に届くように発送します。また、地域によっては、追加費用を負担いただくことにより同日または4時間以内に届くように発送することも可能な場合があります。サポートが必要なときは、Hewlett Packard Enterpriseサポートセンターに電話していただければ、技術者が電話でアドバイスします。交換用のCSR部品または同梱物には、故障部品をHewlett Packard Enterpriseに返送する必要があるかどうかが表示されています。故障部品をHewlett Packard Enterpriseに返送する必要がある場合は、指定期限内（通常は5営業日以内）に故障部品をHewlett Packard Enterpriseに返送してください。故障部品を返送する場合は、届いた時の梱包箱に関連書類とともにに入れてください。故障部品を返送しない場合、Hewlett Packard Enterpriseから部品費用が請求されます。カスタマーセルフリペアの際には、Hewlett Packard Enterpriseは送料および部品返送費を全額負担し、使用する宅配便会社や運送会社を指定します。

部品のみ保証サービス

Hewlett Packard Enterprise保証サービスには、部品のみ保証サービスが適用される場合があります。このサービスでは、交換部品は無償で提供されます。

部品のみ保証サービスにおいては、CSR部品をお客様により交換作業していただくことが必須となります。当該部品について、もしもお客様がHewlett Packard Enterpriseに交換作業を依頼される場合には、その修理サービスに関する交通費および人件費がお客様のご負担となります。

客户自行维修

Hewlett Packard Enterprise 产品提供许多客户自行维修 (CSR) 部件，以尽可能缩短维修时间和在更换缺陷部件方面提供更大的灵活性。如果在诊断期间 Hewlett Packard Enterprise (或 Hewlett Packard Enterprise 服务提供商或服务合作伙伴) 确定可以通过使用 CSR 部件完成维修，Hewlett Packard Enterprise 将直接把该部件发送给您进行更换。有两类 CSR 部件：

- **强制性的** — 要求客户必须自行维修的部件。如果您请求 Hewlett Packard Enterprise 更换这些部件，则必须为该服务支付差旅费和人工费用。
- **可选的** — 客户可以选择是否自行维修的部件。这些部件也是为客户自行维修设计的。不过，如果您要求 Hewlett Packard Enterprise 为您更换这些部件，则根据为您的产品指定的保修服务类型，Hewlett Packard Enterprise 可能收取或不再收取任何附加费用。

注：某些 Hewlett Packard Enterprise 部件的设计并未考虑客户自行维修。为了满足客户保修的需要，Hewlett Packard Enterprise 要求授权服务提供商更换相关部件。这些部件在部件图解目录中标记为“否”。

CSR 部件将在下一个工作日发运 (取决于备货情况和允许的地理范围)。在允许的地理范围内，可在当天或四小时内发运，但要收取额外费用。如果需要帮助，您可以致电 Hewlett Packard Enterprise 技术支持中心，将会有技术人员通过电话为您提供帮助。Hewlett Packard Enterprise 会在随更换的 CSR 部件发运的材料中指明是否必须将有缺陷的部件返还给 Hewlett Packard Enterprise。如果要求您将有缺陷的部件返还给 Hewlett Packard Enterprise，那么您必须在规定的期限内 (通常是五 (5) 个工作日) 将缺陷部件发给 Hewlett Packard Enterprise。有缺陷的部件必须随所提供的发运材料中的相关文件一起返还。如果未能送还有缺陷的部件，Hewlett Packard Enterprise 可能会要求您支付更换费用。客户自行维修时，Hewlett Packard Enterprise 将承担所有相关运输和部件返回费用，并指定快递商/承运商。

有关 Hewlett Packard Enterprise 客户自行维修计划的详细信息，请与您当地的服务提供商联系。有关北美地区的计划，请访问 Hewlett Packard Enterprise 网站 (<http://www.hpe.com/support/selfrepair>)。

仅部件保修服务

您的 Hewlett Packard Enterprise 有限保修服务可能涉及仅部件保修服务。根据仅部件保修服务条款的规定，Hewlett Packard Enterprise 将免费提供更换的部件。

仅部件保修服务要求进行 CSR 部件更换。如果您请求 Hewlett Packard Enterprise 更换这些部件，则必须为该服务支付差旅费和人工费用。

客戶自行維修

Hewlett Packard Enterprise 產品設計了許多「客戶自行維修」(CSR) 的零件以減少維修時間，並且使得更換瑕疵零件時能有更大的彈性。如果在診斷期間，Hewlett Packard Enterprise (或 Hewlett Packard Enterprise 服務供應商或維修夥伴) 辨認出此項維修工作可以藉由使用 CSR 零件來完成，則 Hewlett Packard Enterprise 將直接寄送該零件給您作更換。CSR 零件分為兩種類別：

- **強制的** — 客戶自行維修所使用的零件是強制性的。如果您要求 Hewlett Packard Enterprise 更換這些零件，Hewlett Packard Enterprise 將會向您收取此服務所需的外出費用與勞動成本。
- **選購的** — 客戶自行維修所使用的零件是選購的。這些零件也設計用於客戶自行維修之用。不過，如果您要求 Hewlett Packard Enterprise 為您更換，則可能需要也可能不需要負擔額外的費用，端視針對此產品指定的保固服務類型而定。

備註：某些 Hewlett Packard Enterprise 零件沒有消費者可自行維修的設計。為符合客戶保固，Hewlett Packard Enterprise 需要授權的服務供應商更換零件。這些零件在圖示的零件目錄中，被標示為「否」。

基於材料取得及環境允許的情況下，CSR 零件將於下一個工作日以快遞寄送。在環境的允許下當天或四小時內送達，則可能需要額外的費用。若您需要協助，可致電 Hewlett Packard Enterprise 支援中心，會有一位技術人員透過電話來協助您。不論損壞的零件是否必須退回，Hewlett Packard Enterprise 皆會在與 CSR 替換零件一起運送的材料中註明。若要將損壞的零件退回 Hewlett Packard Enterprise，您必須在指定的一段時間內 (通常為五 (5) 個工作天)，將損壞的零件寄回 Hewlett Packard Enterprise。損壞的零件必須與寄送資料中隨附的相關技術文件一併退還。如果無法退還損壞的零件，Hewlett Packard Enterprise 可能要向您收取替換費用。針對客戶自行維修情形，Hewlett Packard Enterprise 將負責所有運費及零件退還費用，並指定使用何家快遞/貨運公司。

如需 Hewlett Packard Enterprise 的 CSR 方案詳細資訊，請連絡您當地的服務供應商。至於北美方案，請參閱 Hewlett Packard Enterprise 的 CSR 網站repair (<http://www.hpe.com/support/selfrepair>)。

僅限零件的保固服務

您的「Hewlett Packard Enterprise 有限保固」可能包含僅限零件的保固服務。在僅限零件的保固服務情況下，Hewlett Packard Enterprise 將免費提供替換零件。

針對僅限零件的保固服務，CSR 零件替換是強制性的。如果您要求 Hewlett Packard Enterprise 更換這些零件，Hewlett Packard Enterprise 將會向您收取此服務所需的外出費用與勞動成本。

고객 셀프 수리

Hewlett Packard Enterprise 제품은 수리 시간을 최소화하고 결함이 있는 부품 교체 시 더욱 용동성을 발휘할 수 있도록 하기 위해 고객 셀프 수리(CSR) 부품을 다량 사용하여 설계되었습니다. 진단 기간 동안 Hewlett Packard Enterprise(또는 Hewlett Packard Enterprise 서비스 공급업체 또는 서비스 협력업체)에서 CSR 부품을 사용하여 수리가 가능하다고 판단되면 Hewlett Packard Enterprise는 해당 부품을 바로 사용자에게 보내어 사용자가 교체할 수 있도록 합니다. CSR 부품에는 두 가지 종류가 있습니다.

- 필수 - 고객 셀프 수리가 의무 사항인 필수 부품. 사용자가 Hewlett Packard Enterprise에 이 부품의 교체를 요청할 경우 이 서비스에 대한 출장비 및 작업비가 청구됩니다.
- 선택 사항 - 고객 셀프 수리가 선택 사항인 부품. 이 부품들도 고객 셀프 수리가 가능하도록 설계되었습니다. 하지만 사용자가 Hewlett Packard Enterprise에 이 부품의 교체를 요청할 경우 사용자가 구입한 제품에 해당하는 보증 서비스 유형에 따라 추가 비용 없이 교체가 가능할 수 있습니다.

참고: 일부 Hewlett Packard Enterprise 부품은 고객 셀프 수리가 불가능하도록 설계되었습니다. Hewlett Packard Enterprise는 만족스러운 고객 보증을 위해 공인 서비스 제공업체를 통해 부품을 교체하도록 하고 있습니다. 이러한 부품들은 Illustrated Parts Catalog에 "No"라고 표시되어 있습니다.

CSR 부품은 재고 상태와 지리적 조건이 허용하는 경우 다음 영업일 납품이 가능하도록 배송이 이루어집니다. 지리적 조건이 허용하는 경우 추가 비용이 청구되는 조건으로 당일 또는 4시간 배송이 가능할 수도 있습니다. 도움이 필요하시면 Hewlett Packard Enterprise Support Center로 전화하십시오. 전문 기술자가 전화로 도움을 줄 것입니다. Hewlett Packard Enterprise는 결함이 발생한 부품을 Hewlett Packard Enterprise로 반환해야 하는지 여부를 CSR 교체 부품과 함께 배송된 자료에 지정합니다. 결함이 발생한 부품을 Hewlett Packard Enterprise로 반환해야 하는 경우에는 지정된 기간 내(통상 영업일 기준 5일)에 Hewlett Packard Enterprise로 반환해야 합니다. 이때 결함이 발생한 부품은 제공된 포장 재료에 넣어 관련 설명서와 함께 반환해야 합니다. 결함이 발생한 부품을 반환하지 않는 경우 Hewlett Packard Enterprise가 교체 부품에 대해 비용을 청구할 수 있습니다. 고객 셀프 수리의 경우, Hewlett Packard Enterprise는 모든 운송 및 부품 반환 비용을 부담하며 이용할 운송업체 및 택배 서비스를 결정합니다.

Hewlett Packard Enterprise CSR 프로그램에 대한 자세한 내용은 가까운 서비스 제공업체에 문의하십시오. 북미 지역의 프로그램에 대해서는 Hewlett Packard Enterprise CSR 웹 사이트(<http://www.hpe.com/support/selfrepair>)를 참조하십시오.

부품 제공 보증 서비스

Hewlett Packard Enterprise 제한 보증에는 부품 제공 보증 서비스가 포함될 수 있습니다. 이러한 경우 Hewlett Packard Enterprise는 부품 제공 보증 서비스의 조건에 따라 교체 부품만을 무료로 제공합니다.

부품 제공 보증 서비스 제공 시 CSR 부품 교체는 의무 사항입니다. 사용자가 Hewlett Packard Enterprise에 이 부품의 교체를 요청할 경우 이 서비스에 대한 출장비 및 작업비가 청구됩니다.

Illustrated parts catalog

Mechanical components

Hewlett Packard Enterprise continually improves and changes product parts. For complete and current supported parts information, see the Hewlett Packard Enterprise PartSurfer website (<http://www.hpe.com/info/partssurfer>).

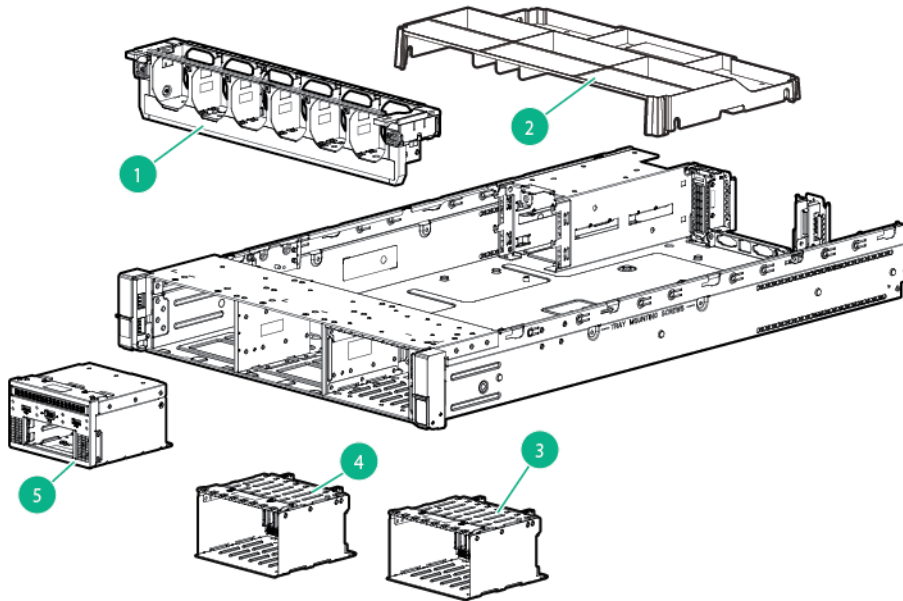

Item	Description	Spare part number	Customer self repair (on page 5)
1	Fan cage	812913-001	Mandatory ¹
2	Air baffle	812915-001	Mandatory ¹
3	Drive cage - Bay 3	779086-001	Mandatory ¹
4	Drive cage - Bay 2	779086-001	Mandatory ¹
5	Drive cage - Bay 1	779086-001	Mandatory ¹
6	Access panel*	812912-001	Mandatory ¹
7	PCIe riser cage*	—	—
	a) Primary 3-slot riser cage	777281-001	Mandatory ¹
	b) Secondary riser cage	777282-001	Mandatory ¹
8	Hard drive blank*	670033-001	Mandatory ¹
9	DIMM blank*	814059-001	Mandatory ¹
10	CPU blank*	775423-001	Mandatory ¹
11	Hardware blank cover kit*	777301-001	Mandatory ¹
	a) Power supply blank	—	—
	b) Drive cage blank cover (2)	—	—

Item	Description	Spare part number	Customer self repair (on page 5)
	c) Secondary PCI blank cover	—	—
	d) Fan blank (2)	—	—
	e) Smart Array Controller blank	—	—
12	Rail kit*	—	—
	a) LFF 2U easy install rail kit	744115-001	Mandatory ¹
	b) Cable management arm	744116-001	Mandatory ¹
13	Heatsink blank*	775423-001	Mandatory ¹
14	Miscellaneous hardware kit*	602506-001	Mandatory ¹
15	Hardware blank kit*	687953-001	Mandatory ¹

* Not shown

¹Mandatory—Parts for which customer self repair is mandatory. If you request Hewlett Packard Enterprise to replace these parts, you will be charged for the travel and labor costs of this service.

²Optional—Parts for which customer self repair is optional. These parts are also designed for customer self repair. If, however, you require that Hewlett Packard Enterprise replace them for you, there may or may not be additional charges, depending on the type of warranty service designated for your product.

³No—Some Hewlett Packard Enterprise parts are not designed for customer self repair. In order to satisfy the customer warranty, Hewlett Packard Enterprise requires that an authorized service provider replace the part. These parts are identified as "No" in the Illustrated Parts Catalog.

¹Obligatoire—Pièces pour lesquelles le client doit procéder lui-même aux réparations. Si vous demandez à Hewlett Packard Enterprise de procéder au remplacement de ces pièces, les frais de transport et de main d'œuvre pour ce service vous seront facturés.

²Facultatif—Pièces pour lesquelles une réparation par le client est facultative. Ces pièces sont également conçues pour que le client puisse procéder lui-même aux réparations. Cependant, les frais supplémentaires engendrés par le remplacement de ces pièces par Hewlett Packard Enterprise dépendent du type de service de garantie désigné pour votre produit.

³Non—Certaines pièces Hewlett Packard Enterprise ne sont pas conçues pour être remplacées par le client. Afin de se conformer aux exigences de la garantie la garantie du client, Hewlett Packard Enterprise demande à un fournisseur de services agréé de procéder au remplacement de la pièce. Ces pièces sont signalées par le mot « Non » dans le Catalogue de pièces illustré.

¹Obbligatorio—Parti per le quali il cliente è tenuto a effettuare autonomamente la riparazione. Se si richiede l'intervento di Hewlett Packard Enterprise per la sostituzione di queste parti, al cliente verranno addebitate le spese di viaggio e manodopera dell'operazione.

²Facoltativo—Parti per le quali la riparazione in autonomia da parte del cliente è facoltativa. Queste parti sono progettate per consentire anche la riparazione da parte del cliente. Tuttavia, se il cliente richiede l'intervento di Hewlett Packard Enterprise per la sostituzione, potrebbero essere addebitate spese aggiuntive a seconda del tipo di garanzia in assistenza previsto per il prodotto.

³No—Alcune parti Hewlett Packard Enterprise non sono progettate la riparazione in autonomia da parte del cliente. In base a quanto previsto dalla garanzia per il cliente, Hewlett Packard Enterprise richiede l'intervento di un tecnico autorizzato per la sostituzione della parte. Queste parti sono contrassegnate con "No" nel catalogo parti illustrato.

¹Zwingend—Teile, für die das Customer Self Repair-Verfahren zwingend vorgegeben ist. Wenn Sie den Austausch dieser Teile von Hewlett Packard Enterprise vornehmen lassen, werden Ihnen die Anfahrt- und Arbeitskosten für diesen Service berechnet.

²Optional—Teile, für die das Customer Self Repair-Verfahren optional ist. Diese Teile sind auch für Customer Self Repair ausgelegt. Wenn Sie jedoch den Austausch dieser Teile von Hewlett Packard Enterprise vornehmen lassen möchten, können bei diesem Service je nach den für Ihr Produkt vorgesehenen Garantiebedingungen zusätzliche Kosten anfallen.

³Nein—Einige Hewlett Packard Enterprise Teile sind nicht für Customer Self Repair ausgelegt. Um den Garantieanspruch des Kunden zu erfüllen, muss das Teil von einem Hewlett Packard Enterprise Servicepartner ersetzt werden. Im illustrierten Teilekatalog sind diese Teile mit „No“ bzw. „Nein“ gekennzeichnet.

¹Obligatorio—Componentes cuya reparación por parte del usuario es obligatoria. Si solicita a Hewlett Packard Enterprise que realice la sustitución de estos componentes, tendrá que hacerse cargo de los gastos de desplazamiento y de mano de obra de dicho servicio.

²Opcional—Componentes cuya reparación por parte del usuario es opcional. Estos componentes también están diseñados para que puedan ser reparados por el usuario. Sin embargo, si precisa que Hewlett Packard Enterprise realice su sustitución, puede o no conllevar costes adicionales, dependiendo del tipo de servicio de garantía correspondiente al producto.

³No—Algunos componentes de Hewlett Packard Enterprise no están diseñados para que puedan ser reparados por el usuario. Para que el usuario haga valer su garantía, Hewlett Packard Enterprise pone como condición que un proveedor de servicios autorizado realice la sustitución de estos componentes. Dichos componentes se identifican con la palabra "No" en el catálogo ilustrado de componentes.

¹Verplicht—Onderdelen die de klant zelf moet vervangen. Als u Hewlett Packard Enterprise vraagt deze onderdelen te vervangen, worden er reis- en arbeidskosten voor deze service in rekening gebracht.

²Optioneel—Onderdelen die de klant zelf kan vervangen. Deze onderdelen zijn ook ontworpen om door de klant zelf te worden vervangen. Als u Hewlett Packard Enterprise verzoekt om deze te vervangen, kan het zijn dat hiervoor extra kosten in rekening worden gebracht, afhankelijk van het soort garantie dat op uw product van toepassing is.

³Geen—Sommige onderdelen van Hewlett Packard Enterprise zijn niet ontworpen om door de klant zelf te worden vervangen. Om te voldoen aan de garantievooraarden eist Hewlett Packard Enterprise dat een geautoriseerde serviceverlener het onderdeel vervangt. Deze onderdelen worden aangeduid met 'Geen' in de geïllustreerde onderdelencatalogus.

¹Obrigatório—Peças cujo reparo feito pelo cliente é obrigatório. Se desejar que a Hewlett Packard Enterprise substitua essas peças, serão cobradas as despesas de transporte e mão-de-obra do serviço.

²Opcional—Peças cujo reparo feito pelo cliente é opcional. Essas peças também são projetadas para o reparo feito pelo cliente. No entanto, se desejar que a Hewlett Packard Enterprise as substitua, pode haver ou não a cobrança de taxa adicional, dependendo do tipo de serviço de garantia destinado ao produto.

³Não—Algumas peças da Hewlett Packard Enterprise não são projetadas para o reparo feito pelo cliente. A fim de cumprir a garantia do cliente, a Hewlett Packard Enterprise exige que um técnico autorizado substitua a peça. Essas peças estão identificadas com a marca "No" (Não), no catálogo de peças ilustrado.

¹Mandatory : 必須 — カスタマーセルフリペアが必須の部品。当該部品について、もしもお客様がHewlett Packard Enterpriseに交換作業を依頼される場合には、その修理サービスに関する交通費および人件費がお客様に請求されます。

²Optional : 任意 — カスタマーセルフリペアが任意である部品。この部品もカスタマーセルフリペア用です。当該部品について、もしもお客様がHewlett Packard Enterpriseに交換作業を依頼される場合には、お買い上げの製品に適用される保証サービス内容の範囲内においては、別途費用を負担していただくことなく保証サービスを受けることができます。

³No : 除外 — Hewlett Packard Enterprise製品の一部の部品は、カスタマーセルフリペアの対象外です。製品の保証を継続するためには、Hewlett Packard EnterpriseまたはHewlett Packard Enterprise正規保守代理店による交換作業が必須となります。部品カタログには、当該部品がカスタマーセルフリペア除外品である旨が記載されています。

¹Mandatory — 客户必须自行维修的部件。如果您请求 Hewlett Packard Enterprise 更换这些部件，则必须为该服务支付差旅费和人工费用。

²Optional — 客户可以选择是否自行维修的部件。这些部件也是为客户自行维修设计的。不过，如果您要求 Hewlett Packard Enterprise 为您更换这些部件，则根据为您的产品指定的保修服务类型，Hewlett Packard Enterprise 可能收取或不再收取任何附加费用。

³No — 某些 Hewlett Packard Enterprise 部件的设计并未考虑客户自行维修。为了满足客户保修的需要，Hewlett Packard Enterprise 要求授权服务提供商更换相关部件。这些部件在部件图解目录中标记为“否”。

¹Mandatory — 客戶自行維修所使用的零件是強制性的。如果您要求 Hewlett Packard Enterprise 更換這些零件，Hewlett Packard Enterprise 將會向您收取此服務所需的外出費用與勞動成本。

²Optional — 客戶自行維修所使用的零件是選購的。這些零件也設計用於客戶自行維修之用。不過，如果您要求 Hewlett Packard Enterprise 為您更換，則可能需要也可能不需要負擔額外的費用，端視針對此產品指定的保固服務類型而定。

³No — 某些 Hewlett Packard Enterprise 零件沒有消費者可自行維修的設計。為符合客戶保固，Hewlett Packard Enterprise 需要授權的服務供應商更換零件。這些零件在圖示的零件目錄中，被標示為「否」。

¹Mandatory — 고객 셀프 수리가 의무 사항인 필수 부품. 사용자가 Hewlett Packard Enterprise에 이 부품의 교체를 요청할 경우 해당 서비스에 대한 출장비 및 작업비가 청구됩니다.

²Optional — 고객 셀프 수리가 선택 사항인 부품. 이러한 부품들도 고객 셀프 수리가 가능하도록 설계되었습니다. 하지만 사용자가 Hewlett Packard Enterprise에 이러한 부품의 교체를 요청할 경우 사용자가 구입한 제품에 해당하는 보증 서비스 유형에 따라 추가 비용 없이 교체가 가능할 수 있습니다.

³No — 일부 Hewlett Packard Enterprise 부품은 고객 셀프 수리가 불가능하도록 설계되었습니다. Hewlett Packard Enterprise는 만족스러운 고객 보증을 위해 공인 서비스 제공업체를 통해 부품을 교체하도록 요구하고 있습니다. 이러한 부품들은 Illustrated Parts Catalog에 "No"라고 표시되어 있습니다.

System components

Hewlett Packard Enterprise continually improves and changes product parts. For complete and current supported parts information, see the Hewlett Packard Enterprise PartSurfer website (<http://www.hpe.com/info/partssurfer>).

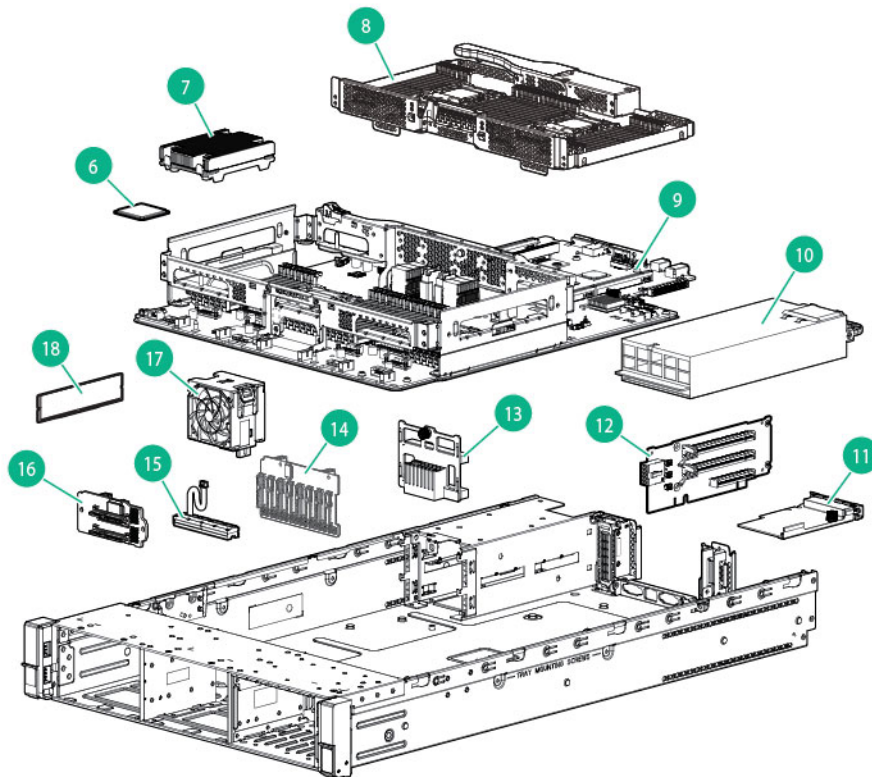

Item	Description	Spare part number	Customer self repair (on page 5)
6	Processors	—	—
	Intel Xeon E5-4600 v3 processors	—	—
	a) 2.1-GHz Intel Xeon processor E5-4660 v3 120 W	791911-001	Optional ²
	b) 2.1-GHz Intel Xeon processor E5-4650 v3 105 W*	791912-001	Optional ²
	c) 1.9-GHz Intel Xeon processor E5-4640 v3 105 W*	791913-001	Optional ²
	d) 2.0-GHz Intel Xeon processor E5-4620 v3 105 W*	791914-001	Optional ²
	e) 1.7-GHz Intel Xeon processor E5-4610 v3 105 W*	791915-001	Optional ²
	f) 2.1-GHz Intel Xeon processor E5-4669 v3 135 W*	791916-001	Optional ²
	g) 2.0-GHz Intel Xeon processor E5-4667 v3 135 W*	791917-001	Optional ²
	h) 2.5-GHz Intel Xeon processor E5-4627 v3 135 W*	791918-001	Optional ²
	i) 2.3-GHz Intel Xeon processor E5-4655 v3 135 W*	791919-001	Optional ²
	Intel Xeon E5-4600 v4 processors	—	—

Item	Description	Spare part number	Customer self repair (on page 5)
	a) 2.5-GHz Intel Xeon processor E5-4660 v4 120 W*	852381-001	Optional ²
	b) 2.4-GHz Intel Xeon processor E5-4650 v4 105 W*	852380-001	Optional ²
	c) 2.3-GHz Intel Xeon processor E5-4640 v4 105 W*	852379-001	Optional ²
	d) 2.4-GHz Intel Xeon processor E5-4620 v4 105 W*	852378-001	Optional ²
	e) 1.8-GHz Intel Xeon processor E5-4610 v4 105 W*	852377-001	Optional ²
	f) 2.5-GHz Intel Xeon processor E5-4669 v4 135 W*	852385-001	Optional ²
	g) 2.5-GHz Intel Xeon processor E5-4667 v4 135 W*	852384-001	Optional ²
	h) 3.2-GHz Intel Xeon processor E5-4627 v4 135 W*	852382-001	Optional ²
	i) 3.2-GHz Intel Xeon processor E5-4655 v4 135 W*	852383-001	Optional ²
7	Heatsink, standard efficiency	812911-001	Optional ²
8	Processor/memory mezzanine tray	812910-001	Mandatory ¹
9	System board assembly	812907-001	Optional ²
10	Power Supplies	—	—
	a) Power supply, hot-plug 1200 W, Platinum Plus	748896-001	Mandatory ¹
	b) Power supply, hot-plug 1500 W Platinum Plus*	704604-001	Mandatory ¹
	c) Power supply, hot-plug 1500 W -48 VDC Common Slot*	794734-001	Mandatory ¹
11	FlexibleLOM	—	—
	a) HPE 1GbE 4-port, 331FLR Adapter FIO Kit	634025-001	Mandatory ¹
	b) HPE 10GbE 2-port, 530FLR Adapter FIO Kit*	649869-001	Mandatory ¹
	c) HPE Flexfabric 10Gb 2-port, 554FLR-SFP+ Adapter FIO Kit*	634026-001	Mandatory ¹
	d) HPE InfiniBand FDR/EN 10/40Gb 2-port, 544FLR-QSFP Adapter*	656090-001	Mandatory ¹
	e) HPE InfiniBand QDR/EN 10Gb 2-port, 544FLR-QSFP Adapter*	656091-001	Mandatory ¹
12	PCIe riser board	—	—
	a) PCIe riser board, primary 3-slot, x8	777281-001	Optional ²
	b) PCIe riser board, secondary 3-slot, x8	777283-001	Optional ²
13	Power supply backplane	662528-001	Mandatory ¹
14	SAS backplane, 8SFF 12 Gbs	777279-001	Optional ²
15	HPE Smart Storage Battery	750450-001	Optional ²
16	SAS backplane, 2SFF	777280-001	Optional ²
17	Hot-plug fan module	777286-001	Mandatory ¹
18	DIMMs	—	—
	DIMMs designed for Intel Xeon E5-4600 v3 processors	—	—
	a) 8 GB, 1Rx4, PC4-2133R	774170-001	Mandatory ¹
	b) 8 GB, 2Rx8, PC4-2133R*	774171-001	Mandatory ¹
	c) 16 GB, 2Rx4, PC4-2133R*	774172-001	Mandatory ¹

Item	Description	Spare part number	Customer self repair (on page 5)
	d) 16 GB, 2Rx4, PC4-2133L*	774173-001	Mandatory ¹
	e) 32 GB, 4Rx4, PC4-2133L*	774174-001	Mandatory ¹
	DIMMs designed for Intel Xeon E5-4600 v4 processors	—	—
	a) 8 GB, PC4-2400R, 1Gx72	819410-001	Mandatory ¹
	b) 16 GB, PC4-2400T-R, 2Gx72	819411-001	Mandatory ¹
	c) 16 GB, PC4-2400R, 2Gx72	846740-001	Mandatory ¹
	d) 32 GB, PC4-2400T	819412-001	Mandatory ¹
	e) 32 GB, PC4-2400T-L, 4Gx72	819414-001	Mandatory ¹
19	SAS drives	—	—
	a) 800 GB 12G SAS SFF, VE, SC EV	762749-001	Mandatory ¹
	b) 1.6-TB 12G SAS SFF, VE, SC, EV*	762751-001	Mandatory ¹
	c) 600 GB 12G SAS 10K SFF, SC HDD*	781577-001	Mandatory ¹
	d) 1.2-TB 12G SAS 10K SFF, SC HDD*	781578-001	Mandatory ¹
	e) 300 GB 12G SAS 10K SFF, SC, HDD*	785410-001	Mandatory ¹
	f) 900 GB 12G SAS 10K SFF, SC HDD*	785411-001	Mandatory ¹
	g) 1.8-TB, 12G SAS 10K SFF, SC 512e format, HDD*	791055-001	Mandatory ¹
	h) 300 GB 12G SAS 15K SFF, SC HDD*	759546-001	Mandatory ¹
	i) 450 GB 12G SAS 15K SFF, SC*	759547-001	Mandatory ¹
	j) 600 GB 12G SAS 15K SFF SC HDD*	759548-001	Mandatory ¹
	k) 200 GB 12G SAS SFF, MLC, SC, VE*	780430-001	Mandatory ¹
	l) 400 GB 12G SAS SFF, MLC, SC, EM, SSD*	780432-001	Mandatory ¹
	m) 800 GB 12G SAS SFF, ME, EM, SC, SSD*	780434-001	Mandatory ¹
	n) 1.6-TB 12G SAS SFF, ME, EM, SC, SSD*	780436-001	Mandatory ¹
	o) 200 GB 12G SAS SFF, WI, SC, SSD*	802905-001	Mandatory ¹
	p) 400 GB 12G SAS SFF, WI, SC, SSD*	802907-001	Mandatory ¹
	q) 800 GB 12G SAS SFF, WI, SC, SSD*	802909-001	Mandatory ¹
	r) 1.9-TB 12G SAS SFF, RI, SC, SSD*	802911-001	Mandatory ¹
	s) 1.2-TB 6G SAS 10K Dual Port, SC, SSD*	718292-001	Mandatory ¹
	t) 600 GB 12G SAS 15K SFF, SC, 512e format, HDD*	748387-001	Mandatory ¹
	u) 1-TB 12G SAS 7.2k SFF, 512e format, SC, HDD*	765872-001	Mandatory ¹
	v) 2-TB 12G SAS 7.2K SFF, 512e format, SC, HDD*	765873-001	Mandatory ¹
	w) 200 GB 12G SAS SFF, ME, SC, EM, SSD*	741224-001	Mandatory ¹
	x) 400 GB 12G SAS SFF, ME, SC, EM, SSD*	741226-001	Mandatory ¹

Item	Description	Spare part number	Customer self repair (on page 5)
	y) 800 GB 12G SAS SFF, ME, SC, EM, SSD*	741228-001	Mandatory ¹
	z) 300 GB 6G SAS 10K SFF, SC, HDD*	653955-001	Mandatory ¹
	aa) 450 GB 6G SAS 10K SFF, SC, HDD*	653956-001	Mandatory ¹
	bb) 600 GB 6G SAS 10K SFF, SC, HDD*	653957-001	Mandatory ¹
	cc) 900 GB 6G SAS 10K SFF, SC, HDD*	653971-001	Mandatory ¹
	dd) 146 GB 6G SAS 15K SFF, SC, HDD*	653950-001	Mandatory ¹
	ee) 500 GB 6G SAS 7.2K SFF, SC, MDL, HDD*	653953-001	Mandatory ¹
	ff) 1-TB 6G SAS 7.2K SFF, SC, MDL, HDD*	653954-001	Mandatory ¹
	gg) 400 GB 6G SATA SFF, LE, SC, EL, SSD*	768268-001	Mandatory ¹
20	SATA drives	—	—
	a) 1-TB 6G SATA 7.2K SFF, 512e format, SC, HDD*	765868-001	Mandatory ¹
	b) 2-TB 6G SATA 7.2k SFF, 512e format, SC, HDD*	765869-001	Mandatory ¹
	c) 120 GB 6G SATA SFF, VE, EV, M1, SSD*	765013-001	Mandatory ¹
	d) 240 GB 6G SATA SFF VE, SC, EV, M1, SSD*	765014-001	Mandatory ¹
	e) 480 GB 6G SATA SFF, VE, SC, EV, M1, SSD*	765015-001	Mandatory ¹
	f) 800 GB 6G SATA SFF, VE, SC, EV, M1, SSD*	765016-001	Mandatory ¹
	g) 100 GB 6G SATA SFF, ME, SC, EM, SSD*	692164-001	Mandatory ¹
	h) 200 GB 6G SATA SFF, ME, SC, EM, SSD*	692165-001	Mandatory ¹
	i) 400 GB 6G SATA SFF, ME, SC, EM, SSD*	692166-001	Mandatory ¹
	j) 800 GB 6G SATA SFF, ME, SC, EM, SSD*	692167-001	Mandatory ¹
	k) 120 GB 6G SATA SFF, VE, SC, EB SSD*	718136-001	Mandatory ¹
	l) 80 GB 6G SATA SFF, SC, EB, SSD*	734562-001	Mandatory ¹
	m) 240 GB 6G SATA SFF, VE, SC, EV, SSD*	718137-001	Mandatory ¹
	n) 480 GB 6G SATA SFF, VE, SC, EV, SSD*	718138-001	Mandatory ¹
	o) 800 GB 6G SATA SFF, VE, SC, EV, SSD*	718139-001	Mandatory ¹
	p) 300 GB 6G SATA SFF, VE, SC, EV, SSD*	739954-001	Mandatory ¹
	q) 600 GB 6G SATA SFF, VE, SC, EV, SSD*	739959-001	Mandatory ¹
	r) 120 GB 6G SATA SFF, VE, SC, EV, G1, SSD*	757361-001	Mandatory ¹
	s) 240 GB 6G SATA SFF, VE, SC, EV, G1, SSD*	757366-001	Mandatory ¹
	t) 480 GB 6G SATA SFF, VE, SC, EV, G1, SSD*	757371-001	Mandatory ¹
	u) 500 GB 6G SATA 7.2K SFF, SC, MDL, HDD*	656107-001	Mandatory ¹
	v) 1-TB 6G SATA 7.2K SFF, SC, MDL, HDD*	656108-001	Mandatory ¹
	w) 240 GB 6G SATA SFF, RI, SC, SSD*	789351-001	Mandatory ¹
	x) 480 GB 6G SATA SFF, RI, SC, SSD*	789356-001	Mandatory ¹

Item	Description	Spare part number	Customer self repair (on page 5)
	y) 960 GB 6G SATA SSF, RI, SC, SSD*	789361-001	Mandatory ¹
	z) 960 GB 6G SATA SFF, LE, SC, EL, G1, SSD*	757231-001	Mandatory ¹
	aa) 1.6-TB 6G SATA SFF, VE, SC, EV, SSD*	757381-001	Mandatory ¹
21	Controllers	—	—
	a) HPE Smart Array P440ar Controller*	775413-001	Optional ²
	b) HPE H240ar Smart Host Bus Adapter*	749997-001	Optional ²
22	HP Trusted Platform Module*	505836-001	No ³
23	Power Modules	—	—
	a) Power module without Systems Insight Display*	812908-001	Optional ²
	b) Power module with Systems Insight Display*	812909-001	Optional ²
24	Cable kits	—	—
	a) Mini-SAS, hard drive backplane (Bay 1, Bay 3)*	812916-001	Mandatory ¹
	b) Mini-SAS, P440/Mini-SATA (Bay 1)*	812917-001	Mandatory ¹
	c) Mini-SAS, hard drive backplane/SCSIe (Bay 2)*	812918-001	Mandatory ¹
	d) Mini-SAS, hard drive backplane/slot 7 (Bay 3)*	812919-001	Mandatory ¹
	e) Mini-SAS/SATA (Bays 1 to 3)*	812920-001	Mandatory ¹
	f) Power/SFF hard drives (Bays 1 to 3)*	812921-001	Mandatory ¹
25	System battery, 3.3 V, lithium*	153099-001	Mandatory ¹

*Not shown

**All processors in this HPE ProLiant server must have the same cache size, speed, number of cores, and rated maximum power consumption.

¹Mandatory—Parts for which customer self repair is mandatory. If you request Hewlett Packard Enterprise to replace these parts, you will be charged for the travel and labor costs of this service.

²Optional—Parts for which customer self repair is optional. These parts are also designed for customer self repair. If, however, you require that Hewlett Packard Enterprise replace them for you, there may or may not be additional charges, depending on the type of warranty service designated for your product.

³No—Some Hewlett Packard Enterprise parts are not designed for customer self repair. In order to satisfy the customer warranty, Hewlett Packard Enterprise requires that an authorized service provider replace the part. These parts are identified as "No" in the Illustrated Parts Catalog.

¹Obligatoire—Pièces pour lesquelles le client doit procéder lui-même aux réparations. Si vous demandez à Hewlett Packard Enterprise de procéder au remplacement de ces pièces, les frais de transport et de main d'œuvre pour ce service vous seront facturés.

²Facultatif—Pièces pour lesquelles une réparation par le client est facultative. Ces pièces sont également conçues pour que le client puisse procéder lui-même aux réparations. Cependant, les frais supplémentaires engendrés par le remplacement de ces pièces par Hewlett Packard Enterprise dépendent du type de service de garantie désigné pour votre produit.

³Non—Certaines pièces Hewlett Packard Enterprise ne sont pas conçues pour être remplacées par le client. Afin de se conformer aux exigences de la garantie la garantie du client, Hewlett Packard Enterprise demande à un fournisseur de services agréé de procéder au remplacement de la pièce. Ces pièces sont signalées par le mot « Non » dans le Catalogue de pièces illustré.

¹Obbligatorio—Parti per le quali il cliente è tenuto a effettuare autonomamente la riparazione. Se si richiede l'intervento di Hewlett Packard Enterprise per la sostituzione di queste parti, al cliente verranno addebitate le spese di viaggio e manodopera dell'operazione.

²Facoltativo—Parti per le quali la riparazione in autonomia da parte del cliente è facoltativa. Queste parti sono progettate per consentire anche la riparazione da parte del cliente. Tuttavia, se il cliente richiede l'intervento di Hewlett

Packard Enterprise per la sostituzione, potrebbero essere addebitate spese aggiuntive a seconda del tipo di garanzia in assistenza previsto per il prodotto.

³No—Alcune parti Hewlett Packard Enterprise non sono progettate la riparazione in autonomia da parte del cliente. In base a quanto previsto dalla garanzia per il cliente, Hewlett Packard Enterprise richiede l'intervento di un tecnico autorizzato per la sostituzione della parte. Queste parti sono contrassegnate con "No" nel catalogo parti illustrato.

¹Zwingend—Teile, für die das Customer Self Repair-Verfahren zwingend vorgegeben ist. Wenn Sie den Austausch dieser Teile von Hewlett Packard Enterprise vornehmen lassen, werden Ihnen die Anfahrt- und Arbeitskosten für diesen Service berechnet.

²Optional—Teile, für die das Customer Self Repair-Verfahren optional ist. Diese Teile sind auch für Customer Self Repair ausgelegt. Wenn Sie jedoch den Austausch dieser Teile von Hewlett Packard Enterprise vornehmen lassen möchten, können bei diesem Service je nach den für Ihr Produkt vorgesehenen Garantiebedingungen zusätzliche Kosten anfallen.

³Nein—Einige Hewlett Packard Enterprise Teile sind nicht für Customer Self Repair ausgelegt. Um den Garantieanspruch des Kunden zu erfüllen, muss das Teil von einem Hewlett Packard Enterprise Servicepartner ersetzt werden. Im illustrierten Teilekatalog sind diese Teile mit „No“ bzw. „Nein“ gekennzeichnet.

¹Obligatorio—Componentes cuya reparación por parte del usuario es obligatoria. Si solicita a Hewlett Packard Enterprise que realice la sustitución de estos componentes, tendrá que hacerse cargo de los gastos de desplazamiento y de mano de obra de dicho servicio.

²Opcional—Componentes cuya reparación por parte del usuario es opcional. Estos componentes también están diseñados para que puedan ser reparados por el usuario. Sin embargo, si precisa que Hewlett Packard Enterprise realice su sustitución, puede o no conllevar costes adicionales, dependiendo del tipo de servicio de garantía correspondiente al producto.

³No—Algunos componentes de Hewlett Packard Enterprise no están diseñados para que puedan ser reparados por el usuario. Para que el usuario haga valer su garantía, Hewlett Packard Enterprise pone como condición que un proveedor de servicios autorizado realice la sustitución de estos componentes. Dichos componentes se identifican con la palabra "No" en el catálogo ilustrado de componentes.

¹Verplicht—Onderdelen die de klant zelf moet vervangen. Als u Hewlett Packard Enterprise vraagt deze onderdelen te vervangen, worden er reis- en arbeidskosten voor deze service in rekening gebracht.

²Optioneel—Onderdelen die de klant zelf kan vervangen. Deze onderdelen zijn ook ontworpen om door de klant zelf te worden vervangen. Als u Hewlett Packard Enterprise verzoekt om deze te vervangen, kan het zijn dat hiervoor extra kosten in rekening worden gebracht, afhankelijk van het soort garantie dat op uw product van toepassing is.

³Geen—Sommige onderdelen van Hewlett Packard Enterprise zijn niet ontworpen om door de klant zelf te worden vervangen. Om te voldoen aan de garantievoorwaarden eist Hewlett Packard Enterprise dat een geautoriseerde serviceverlener het onderdeel vervangt. Deze onderdelen worden aangeduid met 'Geen' in de geïllustreerde onderdelencatalogus.

¹Obrigatório—Peças cujo reparo feito pelo cliente é obrigatório. Se desejar que a Hewlett Packard Enterprise substitua essas peças, serão cobradas as despesas de transporte e mão-de-obra do serviço.

²Opcional—Peças cujo reparo feito pelo cliente é opcional. Essas peças também são projetadas para o reparo feito pelo cliente. No entanto, se desejar que a Hewlett Packard Enterprise as substitua, pode haver ou não a cobrança de taxa adicional, dependendo do tipo de serviço de garantia destinado ao produto.

³Não—Algumas peças da Hewlett Packard Enterprise não são projetadas para o reparo feito pelo cliente. A fim de cumprir a garantia do cliente, a Hewlett Packard Enterprise exige que um técnico autorizado substitua a peça. Essas peças estão identificadas com a marca "No" (Não), no catálogo de peças ilustrado.

¹Mandatory : 必須 — カスタマーセルフリペアが必須の部品。当該部品について、もしもお客様がHewlett Packard Enterpriseに交換作業を依頼される場合には、その修理サービスに関する交通費および人件費がお客様に請求されます。

²Optional : 任意 — カスタマーセルフリペアが任意である部品。この部品もカスタマーセルフリペア用です。当該部品について、もしもお客様がHewlett Packard Enterpriseに交換作業を依頼される場合には、お買い上げの製品に適用される保証サービス内容の範囲内においては、別途費用を負担していただくことなく保証サービスを受けることができます。

³No : 除外 — Hewlett Packard Enterprise製品の一部の部品は、カスタマーセルフリペアの対象外です。製品の保証を継続するためには、Hewlett Packard EnterpriseまたはHewlett Packard Enterprise正規保守代理店による交換作業が必須となります。部品カタログには、当該部品がカスタマーセルフリペア除外品である旨が記載されています。

¹Mandatory — 客户必须自行维修的部件。如果您请求 Hewlett Packard Enterprise 更换这些部件，则必须为该服务支付差旅费和人工费用。

²Optional — 客户可以选择是否自行维修的部件。这些部件也是为客户自行维修设计的。不过，如果您要求 Hewlett Packard Enterprise 为您更换这些部件，则根据为您的产品指定的保修服务类型，Hewlett Packard Enterprise 可能收取或不再收取任何附加费用。

³No — 某些 Hewlett Packard Enterprise 部件的设计并未考虑客户自行维修。为了满足客户保修的需要，Hewlett Packard Enterprise 要求授权服务提供商更换相关部件。这些部件在部件图解目录中标记为“否”。

¹Mandatory — 客戶自行維修所使用的零件是強制性的。如果您要求 Hewlett Packard Enterprise 更換這些零件，Hewlett Packard Enterprise 將會向您收取此服務所需的外出費用與勞動成本。

²Optional — 客戶自行維修所使用的零件是選購的。這些零件也設計用於客戶自行維修之用。不過，如果您要求 Hewlett Packard Enterprise 為您更換，則可能需要也可能不需要負擔額外的費用，端視針對此產品指定的保固服務類型而定。

³No — 某些 Hewlett Packard Enterprise 零件沒有消費者可自行維修的設計。為符合客戶保固，Hewlett Packard Enterprise 需要授權的服務供應商更換零件。這些零件在圖示的零件目錄中，被標示為「否」。

¹Mandatory — 고객 셀프 수리가 의무 사항인 필수 부품. 사용자가 Hewlett Packard Enterprise에 이 부품의 교체를 요청할 경우 해당 서비스에 대한 출장비 및 작업비가 청구됩니다.

²Optional — 고객 셀프 수리가 선택 사항인 부품. 이러한 부품들도 고객 셀프 수리가 가능하도록 설계되었습니다. 하지만 사용자가 Hewlett Packard Enterprise에 이러한 부품의 교체를 요청할 경우 사용자가 구입한 제품에 해당하는 보증 서비스 유형에 따라 추가 비용 없이 교체가 가능할 수 있습니다.

³No — 일부 Hewlett Packard Enterprise 부품은 고객 셀프 수리가 불가능하도록 설계되었습니다. Hewlett Packard Enterprise는 만족스러운 고객 보증을 위해 공인 서비스 제공업체를 통해 부품을 교체하도록 요구하고 있습니다. 이러한 부품들은 Illustrated Parts Catalog에 "No"라고 표시되어 있습니다.

Removal and replacement procedures

Required tools

You need the following items for some procedures:

- T-10/T-15 Torx screwdriver
- HPE Insight Diagnostics software ("[HPE Insight Diagnostics](#)" on page 91)

Safety considerations

Before performing service procedures, review all the safety information.

Preventing electrostatic discharge

To prevent damaging the system, be aware of the precautions you need to follow when setting up the system or handling parts. A discharge of static electricity from a finger or other conductor may damage system boards or other static-sensitive devices. This type of damage may reduce the life expectancy of the device.

To prevent electrostatic damage:

- Avoid hand contact by transporting and storing products in static-safe containers.
- Keep electrostatic-sensitive parts in their containers until they arrive at static-free workstations.
- Place parts on a grounded surface before removing them from their containers.
- Avoid touching pins, leads, or circuitry.
- Always be properly grounded when touching a static-sensitive component or assembly.

Symbols on equipment

The following symbols may be placed on equipment to indicate the presence of potentially hazardous conditions.



This symbol indicates the presence of hazardous energy circuits or electric shock hazards. Refer all servicing to qualified personnel.

WARNING: To reduce the risk of injury from electric shock hazards, do not open this enclosure. Refer all maintenance, upgrades, and servicing to qualified personnel.



This symbol indicates the presence of electric shock hazards. The area contains no user or field serviceable parts. Do not open for any reason.

WARNING: To reduce the risk of injury from electric shock hazards, do not open this enclosure.



This symbol on an RJ-45 receptacle indicates a network interface connection.

WARNING: To reduce the risk of electric shock, fire, or damage to the equipment, do not plug telephone or telecommunications connectors into this receptacle.



This symbol indicates the presence of a hot surface or hot component. If this surface is contacted, the potential for injury exists.

WARNING: To reduce the risk of injury from a hot component, allow the surface to cool before touching.



27.66 kg
61.00 lb

This symbol indicates that the component exceeds the recommended weight for one individual to handle safely.

WARNING: To reduce the risk of personal injury or damage to the equipment, observe local occupational health and safety requirements and guidelines for manual material handling.

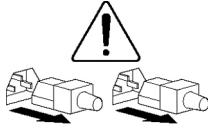

These symbols, on power supplies or systems, indicate that the equipment is supplied by multiple sources of power.

WARNING: To reduce the risk of injury from electric shock, remove all power cords to completely disconnect power from the system.

Server warnings and cautions

Before installing a server, be sure that you understand the following warnings and cautions.



WARNING: To reduce the risk of electric shock or damage to the equipment:

- Do not disable the power cord grounding plug. The grounding plug is an important safety feature.
- Plug the power cord into a grounded (earthed) electrical outlet that is easily accessible at all times.
- Unplug the power cord from the power supply to disconnect power to the equipment.
- Do not route the power cord where it can be walked on or pinched by items placed against it. Pay particular attention to the plug, electrical outlet, and the point where the cord extends from the server.



WARNING: To reduce the risk of personal injury from hot surfaces, allow the drives and the internal system components to cool before touching them.



CAUTION: Do not operate the server for long periods with the access panel open or removed. Operating the server in this manner results in improper airflow and improper cooling that can lead to thermal damage.

Preparation procedures

To access some components and perform certain service procedures, you must perform one or more of the following procedures:

- Extend the server from the rack (on page 27).

If you are performing service procedures in a Hewlett Packard Enterprise, Compaq branded, telco, or third-party rack cabinet, you can use the locking feature of the rack rails to support the server and gain access to internal components.

For more information about telco rack solutions, refer to the RackSolutions.com website (<http://www.racksolutions.com/hp>).

- Power down the server (on page 28).

If you must remove a server from a rack or a non-hot-plug component from a server, power down the server.

- Remove the server from the rack (on page 28).

If the rack environment, cabling configuration, or the server location in the rack creates awkward conditions, remove the server from the rack.

- Access the product rear panel (on page 30).
- Access the Systems Insight Display ("[Access the Systems Insight Display option](#)" on page 30).

Extend the server from the rack

⚠ WARNING: To reduce the risk of personal injury or equipment damage, be sure that the rack is adequately stabilized before extending a component from the rack.

1. Pull down the quick release levers on each side of the server.
2. Extend the server from the rack.

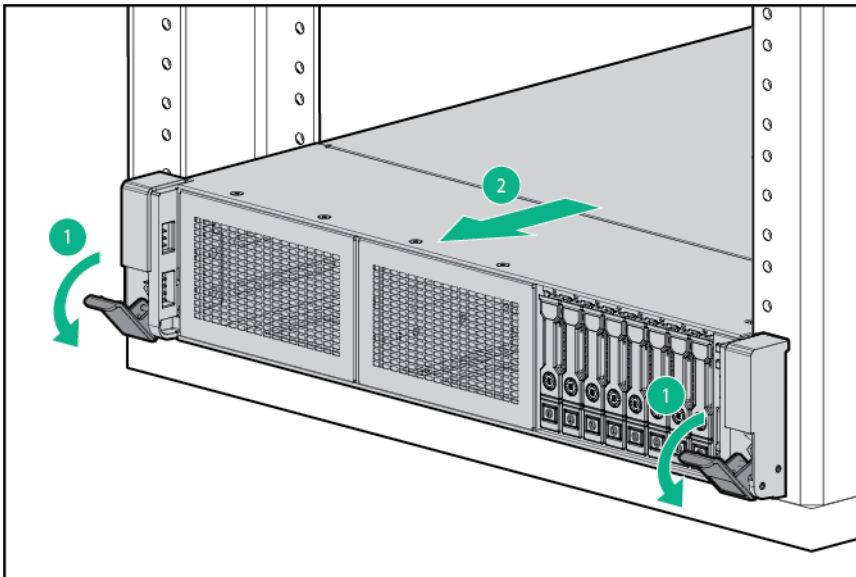

3. After performing the installation or maintenance procedure, slide the server back into the rack, and then press the server firmly into the rack to secure it in place.

⚠ WARNING: To reduce the risk of personal injury, be careful when pressing the server rail-release latches and sliding the server into the rack. The sliding rails could pinch your fingers.

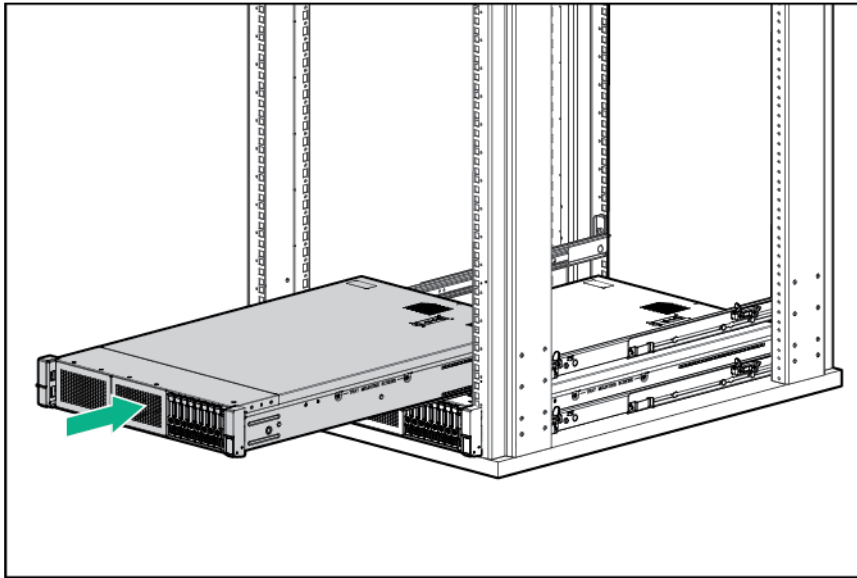

Power down the server

Before powering down the server for any upgrade or maintenance procedures, perform a backup of critical server data and programs.



IMPORTANT: When the server is in standby mode, auxiliary power is still being provided to the system.

To power down the server, use one of the following methods:

- Press and release the Power On/Standby button.
This method initiates a controlled shutdown of applications and the OS before the server enters standby mode.
- Press and hold the Power On/Standby button for more than 4 seconds to force the server to enter standby mode.
This method forces the server to enter standby mode without properly exiting applications and the OS. If an application stops responding, you can use this method to force a shutdown.
- Use a virtual power button selection through HPE iLO.
This method initiates a controlled remote shutdown of applications and the OS before the server enters standby mode.

Before proceeding, verify the server is in standby mode by observing that the system power LED is amber.

Remove the server from the rack



WARNING: To reduce the risk of personal injury or equipment damage, be sure that the rack is adequately stabilized before extending a component from the rack.



WARNING: To reduce the risk of personal injury, be careful when pressing the server rail-release latches and sliding the server into the rack. The sliding rails could pinch your fingers.



This symbol indicates that the component exceeds the recommended weight for one individual to handle safely.

WARNING: To reduce the risk of personal injury or damage to the equipment, observe local occupational health and safety requirements and guidelines for manual material handling.

To remove the server from the rack:

1. Pull down the quick-release levers on each side of the server to release the server from the rack. If necessary, loosen the rack screws.
2. Extend the server on the rack rails until the server rail-release latches engage.

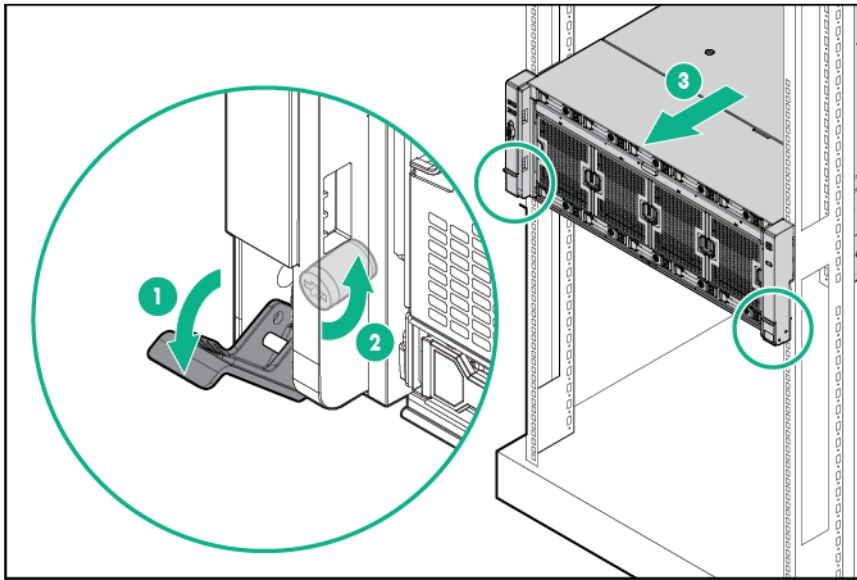

3. Remove the server from the rack.

Access the product rear panel

Opening the cable management arm

To access the server rear panel:

1. Release the cable management arm.

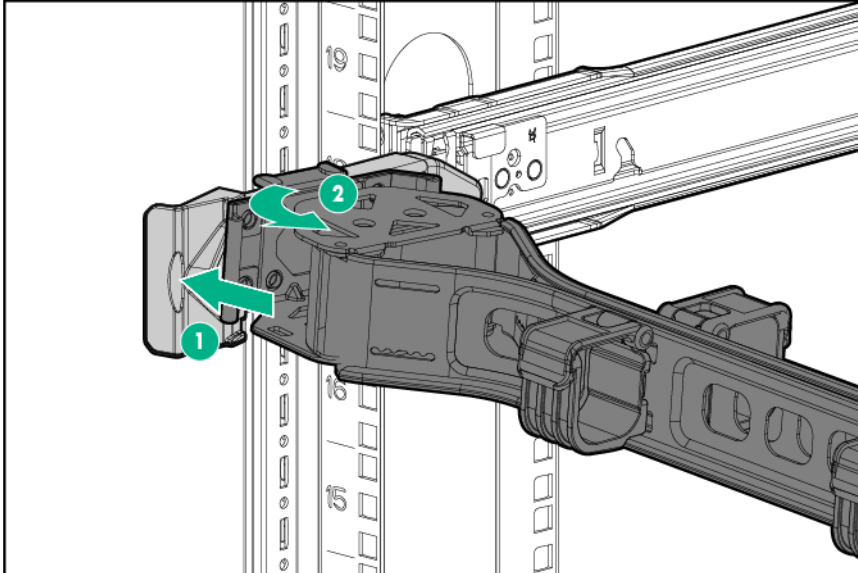

2. Open the cable management arm. The cable management arm can be right-mounted or left-mounted.

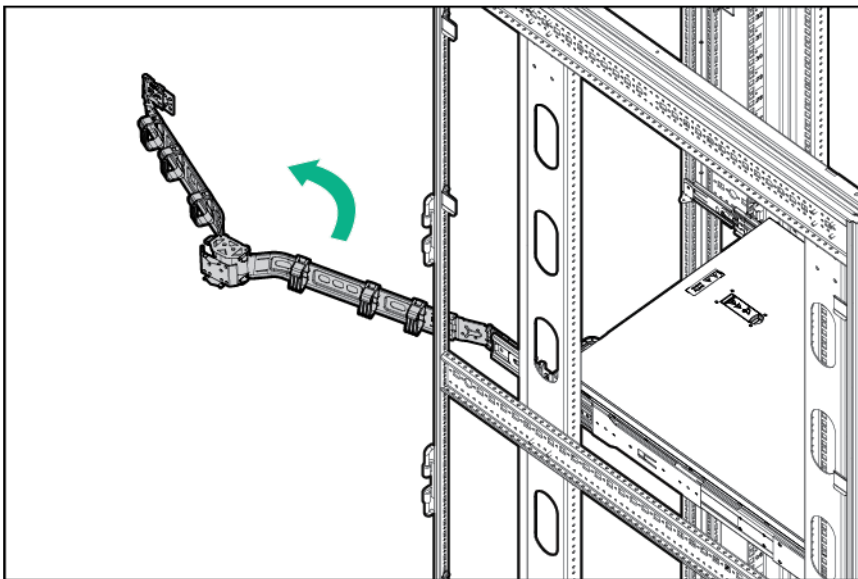

Access the Systems Insight Display option

1. Press and release the panel.

2. After the display fully ejects, rotate the display sideways to view the LEDs.

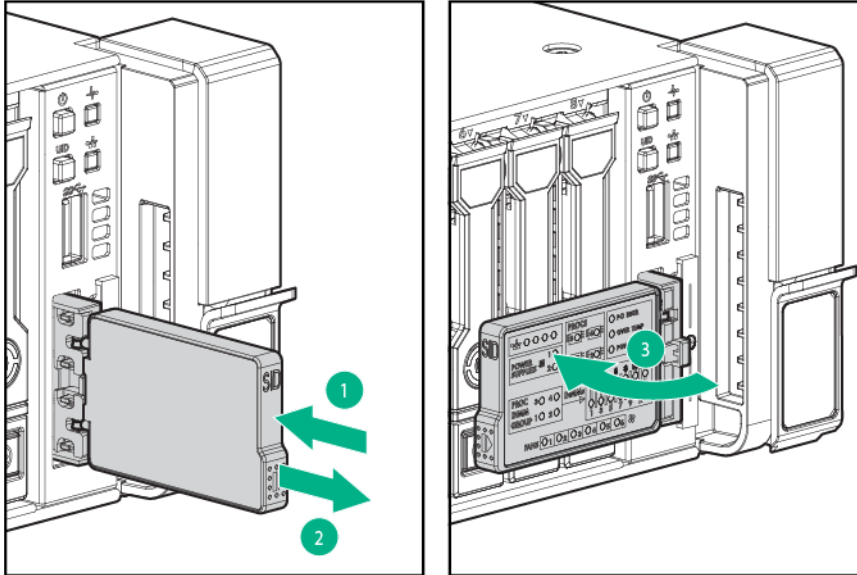

Access panel

- WARNING:** To reduce the risk of personal injury from hot surfaces, allow the drives and the internal system components to cool before touching them.
- WARNING:** To reduce the risk of personal injury, electric shock, or damage to the equipment, remove the power cord to remove power from the server. The front panel Power On/Standby button does not completely shut off system power. Portions of the power supply and some internal circuitry remain active until AC power is removed.
- CAUTION:** For proper cooling, do not operate the server without the access panel, baffles, expansion slot covers, blanks, or the optional mezzanine tray installed. If the server supports hot-plug components, minimize the amount of time the access panel is open.

To remove the component:

1. Power down the server if performing a non-hot-plug installation or maintenance procedure ("[Power down the server](#)" on page 28).
2. Extend the server from the rack (on page 27).
3. Remove the access panel.

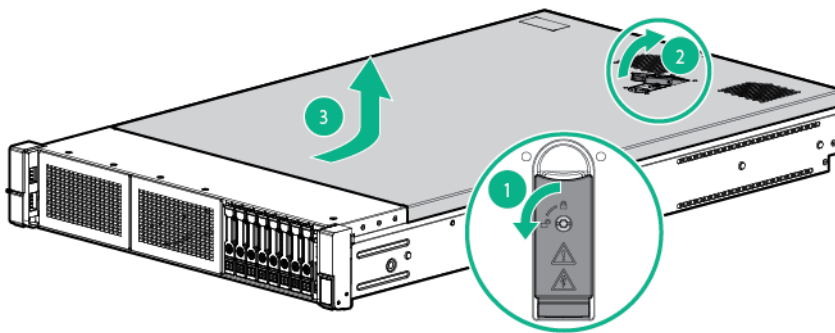

To replace the component, reverse the removal procedure.

Air baffle

WARNING: To reduce the risk of personal injury, electric shock, or damage to the equipment, remove the power cord to remove power from the server. The front panel Power On/Standby button does not completely shut off system power. Portions of the power supply and some internal circuitry remain active until AC power is removed.

CAUTION: For proper cooling, do not operate the server without the access panel, baffles, expansion slot covers, blanks, or the optional mezzanine tray installed. If the server supports hot-plug components, minimize the amount of time the access panel is open.

To remove the component:

1. Power down the server (on page 28).
2. Remove all power:
 - a. Disconnect each power cord from the power source.
 - b. Disconnect each power cord from the server.
3. Extend the server from the rack (on page 27).
4. Remove the access panel ("[Access panel](#)" on page 31).

CAUTION: Do not detach the cable that connects the battery pack to the cache module. Detaching the cable causes any unsaved data in the cache module to be lost.

IMPORTANT: It is necessary to remove the PCI riser cage only if there is a full-length expansion board installed.

5. Remove the air baffle.

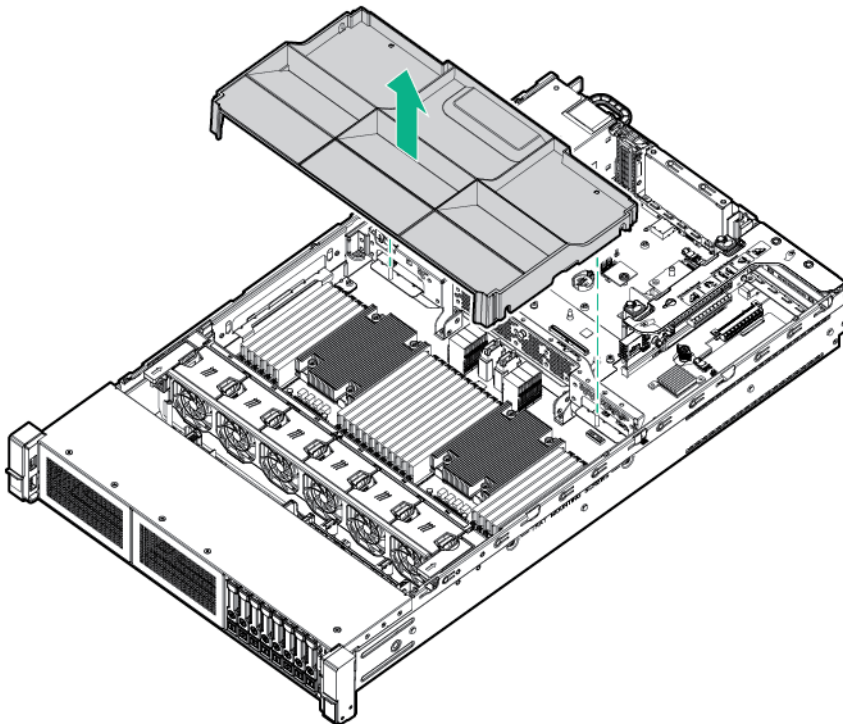

To replace the component, reverse the removal procedure.

Mezzanine tray option

1. Power down the server (on page 28).
2. Remove all power:
 - a. Disconnect each power cord from the power source.
 - b. Disconnect each power cord from the server.
3. Extend the server from the rack (on page 27).
4. Remove the access panel ("Access panel" on page 31).
5. Remove the mezzanine tray.

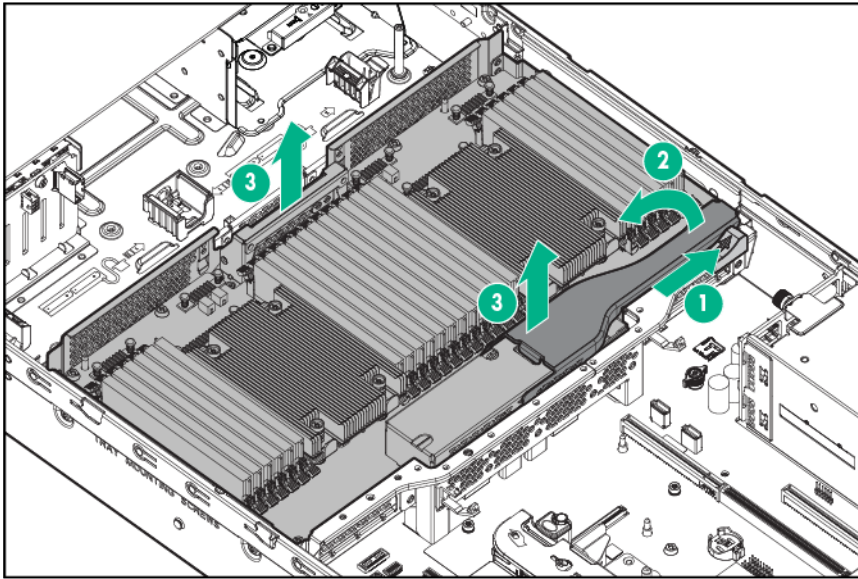

To replace the component, reverse the removal procedure.

Primary 3-slot PCI riser cage

- ⚠ WARNING:** To reduce the risk of personal injury, electric shock, or damage to the equipment, remove the power cord to remove power from the server. The front panel Power On/Standby button does not completely shut off system power. Portions of the power supply and some internal circuitry remain active until AC power is removed.
- ⚠ CAUTION:** To prevent improper cooling and thermal damage, do not operate the server unless all PCI slots have either an expansion slot cover or an expansion board installed.

To install the component:

1. Power down the server (on page 28).
2. Remove all power:
 - a. Disconnect each power cord from the power source.
 - b. Disconnect each power cord from the server.
3. Extend the server from the rack (on page 27).
4. Remove the access panel ("Access panel" on page 31).
5. Remove any expansion board installed in the slot ("Expansion boards" on page 60).

6. Remove the riser cage.

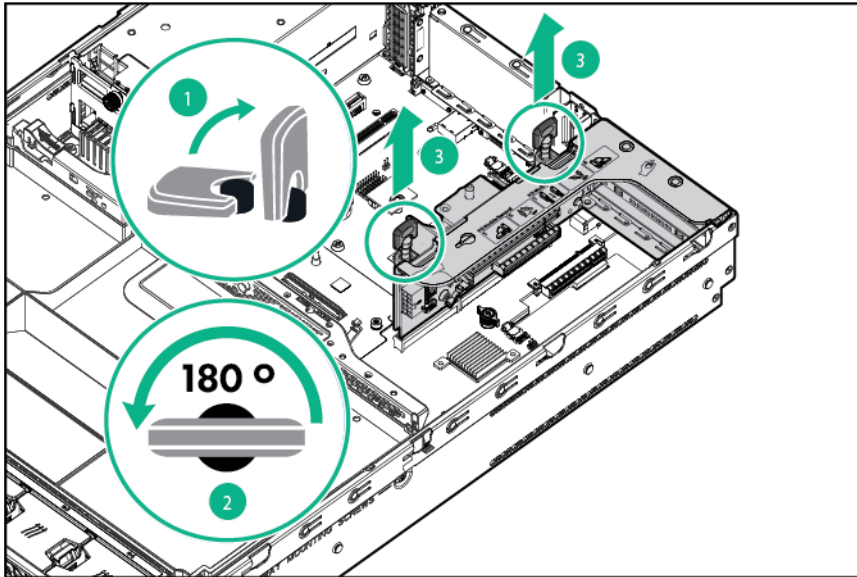

To replace the component, reverse the removal procedure.

PCIe riser board



WARNING: To reduce the risk of personal injury, electric shock, or damage to the equipment, remove the power cord to remove power from the server. The front panel Power On/Standby button does not completely shut off system power. Portions of the power supply and some internal circuitry remain active until AC power is removed.

To remove the component:

1. Power down the server (on page 28).
2. Remove all power:
 - a. Disconnect each power cord from the power source.
 - b. Disconnect each power cord from the server.
3. Extend the server from the rack (on page 27).
4. Remove the access panel ("Access panel" on page 31).
5. Remove the PCIe riser cage ("Primary 3-slot PCI riser cage" on page 33).
6. Remove any expansion board installed in the slot ("Expansion boards" on page 60).

7. Remove the PCIe riser board.

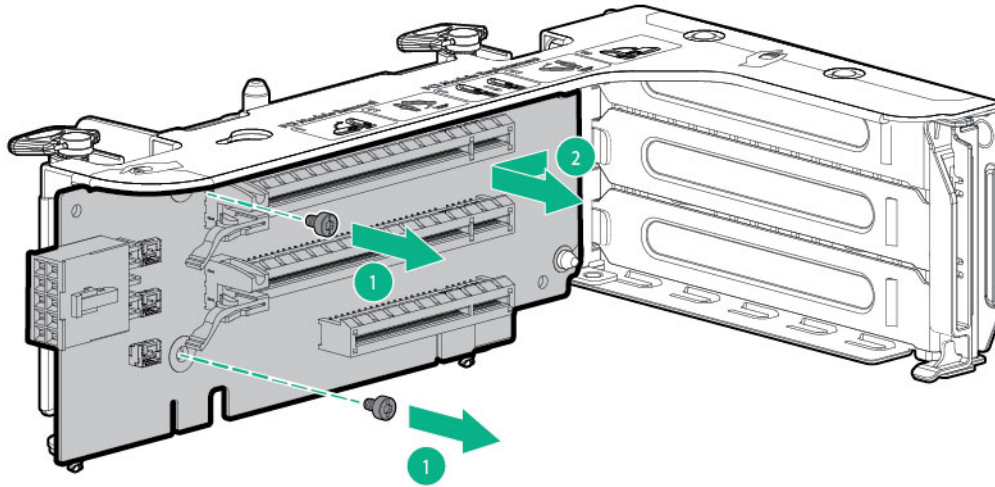

To replace the component, reverse the removal procedure.

Remove the secondary PCI riser cage

1. Power down the server (on page 28).
2. Remove all power:
 - a. Disconnect each power cord from the power source.
 - b. Disconnect each power cord from the server.
3. Extend the server from the rack (on page 27).
4. Remove the access panel ("Access panel" on page 31).
5. Remove any expansion board installed in the slot ("Expansion boards" on page 60).
6. Remove the riser cage.

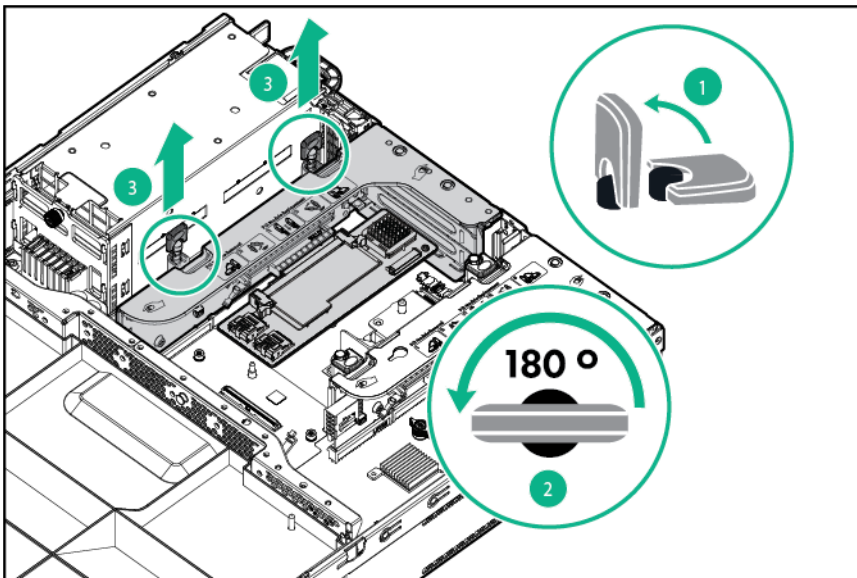

Systems Insight Display

1. Power down the server (on page 28).
2. Remove all power:
 - a. Disconnect each power cord from the power source.
 - b. Disconnect each power cord from the server.
3. Extend the server from the rack (on page 27).
4. Remove the access panel ("Access panel" on page 31).
5. Remove the fan cage ("Fan cage" on page 39).
6. Depending on the server options installed, do one of the following:
 - o Remove the air baffle ("Air baffle" on page 32).
 - o Remove the mezzanine tray ("Mezzanine tray option" on page 33).
7. Disconnect the cabled power switch module cables from the system board.
8. Using a T-10 Torx screwdriver, remove the cabled power switch module. Retain the T-10 screw.

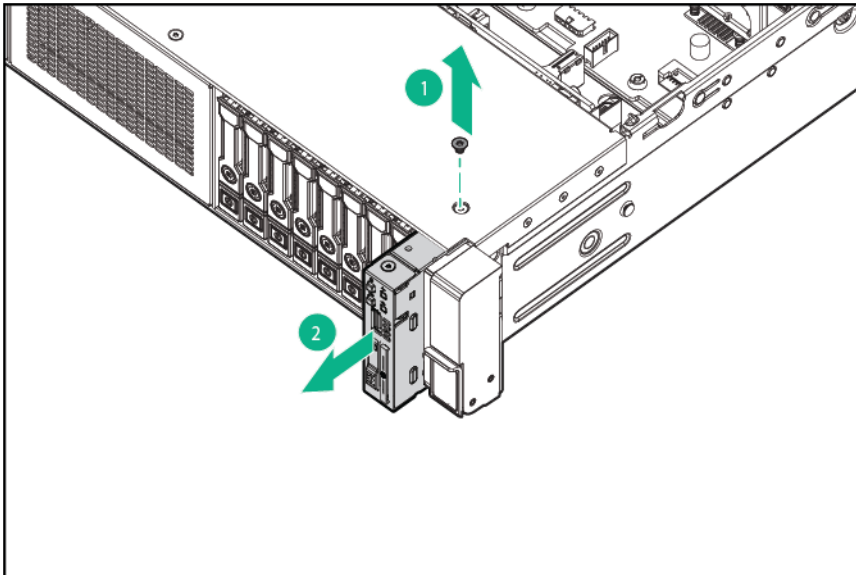

To replace the component:

1. Route the cable through the opening in the front of the server, and then install the SID power switch module. Secure the module using the existing T-10 screw.

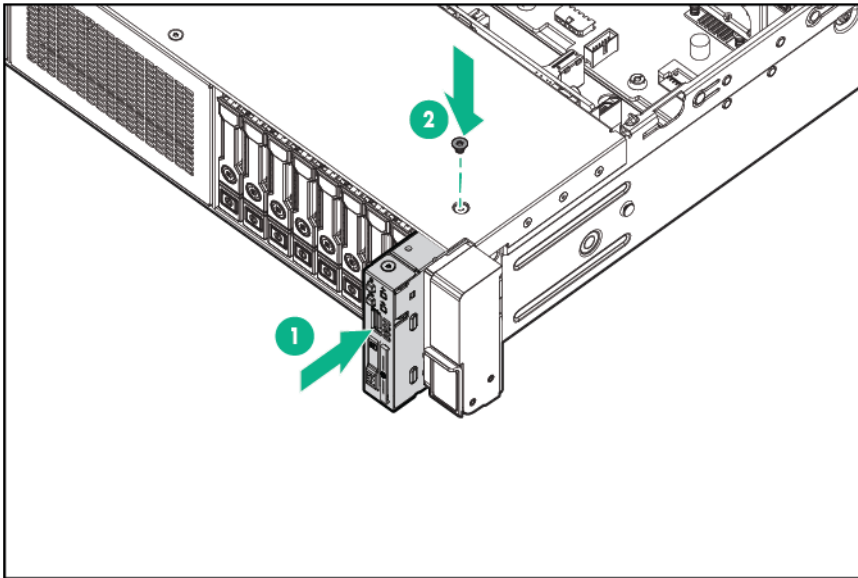

2. Using the cable trough, connect the SID module cable to the front panel connector and to the power switch module connector.

CAUTION: When routing cables, always be sure that the cables are not in a position where they can be pinched or crimped.

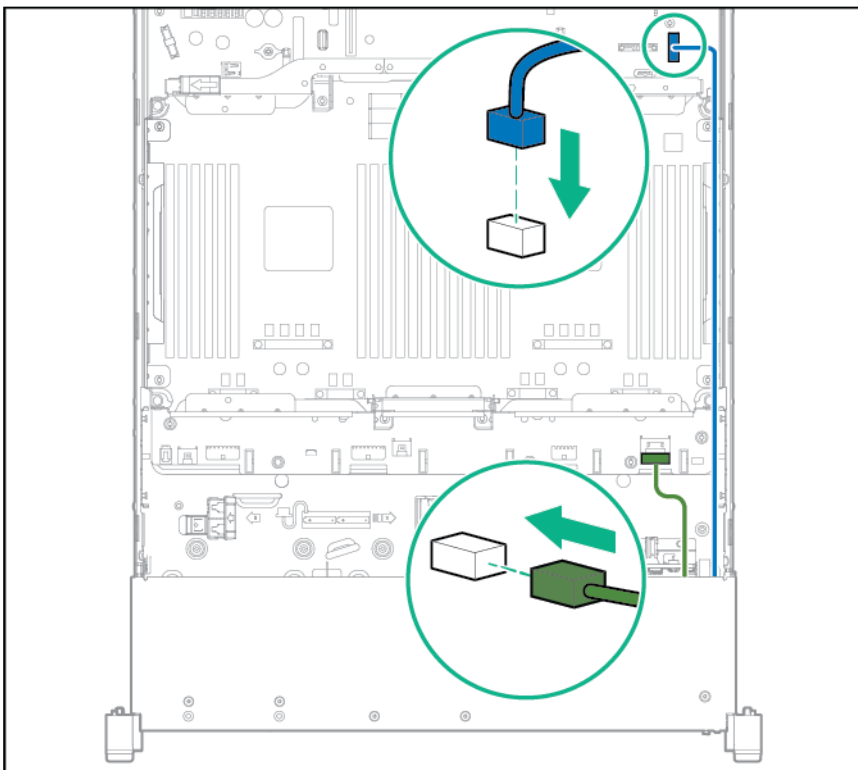

3. Install the fan cage ("Fan cage" on page 39).
4. Depending on the server options installed, do one of the following:
 - Install the air baffle ("Air baffle" on page 32).

- Install the mezzanine tray ("[Mezzanine tray option](#)" on page 33).
5. Install the access panel ("[Access panel](#)" on page 31).
6. Slide the server into the rack.
7. Connect each power cord to the server.
8. Connect each power cord to the power source.
9. Power up the server.

Hot-plug fan

 **CAUTION:** To avoid damage to server components, all fan modules must be installed in fan bays for any processor configuration.

For all processor configurations, the HPE ProLiant DL560 Gen9 Server requires six fan modules for redundancy. A fan failure causes a loss of cooling redundancy. A second fan failure or a missing fan module causes an orderly shutdown of the server.

The server supports variable fan speeds. The fans operate at minimum speed until a temperature change requires a fan speed increase to cool the server.

The server shuts down in the following temperature-related scenarios:

- At POST and in the OS, HPE iLO performs an orderly shutdown if a cautionary temperature level is detected. If the server hardware detects a critical temperature level before an orderly shutdown occurs, the server performs an immediate shutdown.
- When the Thermal Shutdown feature is disabled in RBSU, HPE iLO does not perform an orderly shutdown when a cautionary temperature level is detected. Disabling this feature does not disable the server hardware from performing an immediate shutdown when a critical temperature level is detected.

 **CAUTION:** A thermal event can damage server components when the Thermal Shutdown feature is disabled in RBSU.

 **IMPORTANT:** An immediate shutdown is a hardware-controlled function and it overrides any firmware or software actions.

Removing a hot-plug fan

1. Power down the server (on page 28).
2. Remove all power:
 - a. Disconnect each power cord from the power source.
 - b. Disconnect each power cord from the server.
3. Extend the server from the rack (on page 27).
4. Remove the access panel ("[Access panel](#)" on page 31).

5. Remove the hot-plug fan.

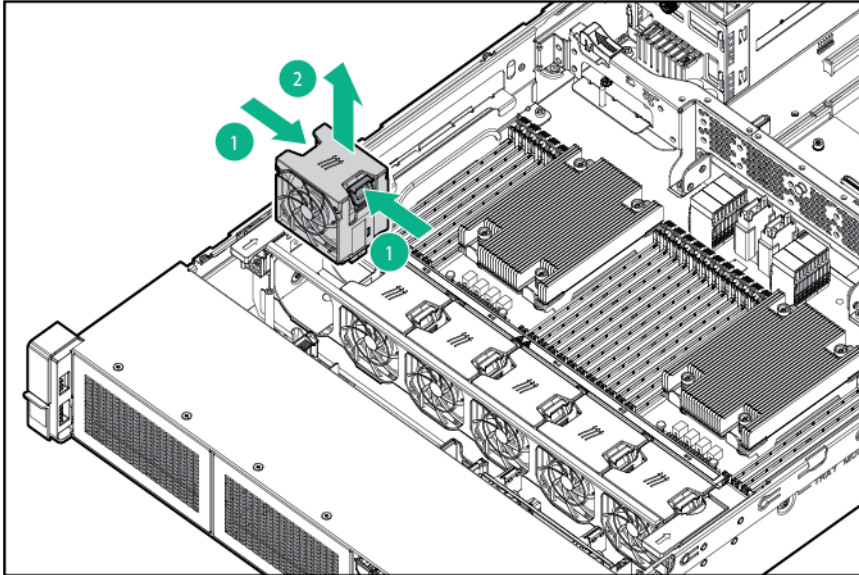

CAUTION: Do not operate the server for long periods with the access panel open or removed. Operating the server in this manner results in improper airflow and improper cooling that can lead to thermal damage.

To replace the component, reverse the removal procedure.

Fan cage

WARNING: To reduce the risk of personal injury, electric shock, or damage to the equipment, remove the power cord to remove power from the server. The front panel Power On/Standby button does not completely shut off system power. Portions of the power supply and some internal circuitry remain active until AC power is removed.

CAUTION: For proper cooling, do not operate the server without the access panel, baffles, expansion slot covers, blanks, or the optional mezzanine tray installed. If the server supports hot-plug components, minimize the amount of time the access panel is open.

To remove the component:

1. Power down the server (on page 28).
2. Remove all power:
 - a. Disconnect each power cord from the power source.
 - b. Disconnect each power cord from the server.
3. Extend the server from the rack (on page 27).
4. Remove the access panel ("Access panel" on page 31).

5. Remove the fan cage.

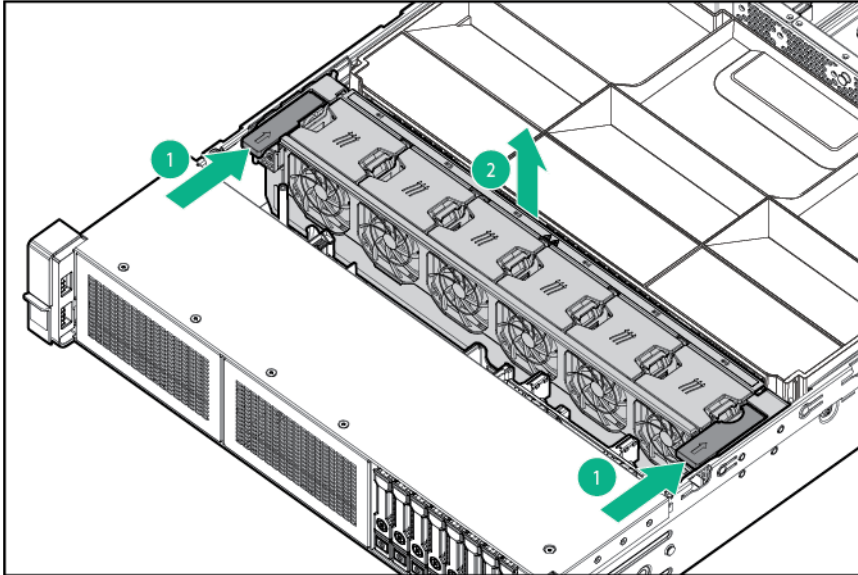

To replace the component, reverse the removal procedure.

Drive blank

- △ **CAUTION:** To prevent improper cooling and thermal damage, do not operate the server unless all bays are populated with either a component or a blank.

To remove the component:

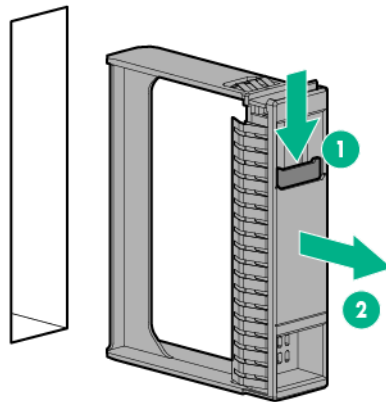

To replace the component, slide the component into the bay until it clicks.

Hot-plug drive

- △ **CAUTION:** For proper cooling, do not operate the server without the access panel, baffles, expansion slot covers, blanks, or the optional mezzanine tray installed. If the server supports hot-plug components, minimize the amount of time the access panel is open.

To remove the component:

1. Determine the status of the drive from the hot-plug drive LED definitions (on page 103).
2. Back up all server data on the drive.

3. Remove the drive.

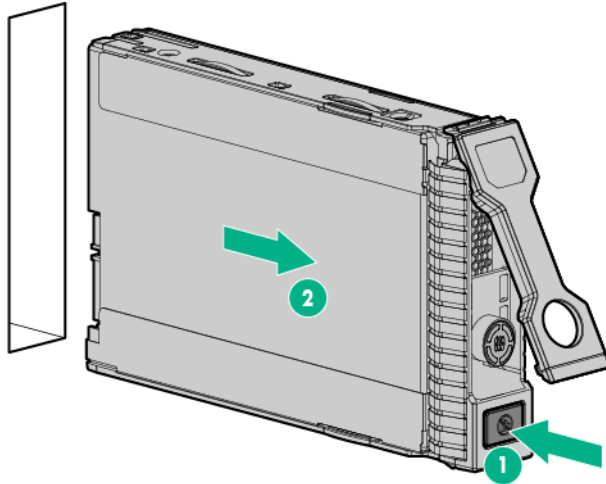

To replace the component, reverse the removal procedure.

8SFF front drive cage

1. Power down the server (on page 28).
2. Remove all power:
 - a. Disconnect each power cord from the power source.
 - b. Disconnect each power cord from the server.
3. Extend the server from the rack (on page 27).
4. Remove the access panel ("[Access panel](#)" on page 31).
5. Remove the fan cage ("[Fan cage](#)" on page 39).
6. Depending on the server options installed, do one of the following:
 - o Remove the air baffle ("[Air baffle](#)" on page 32).
 - o Remove the mezzanine tray ("[Mezzanine tray option](#)" on page 33).
7. Remove all hard drives ("[Hot-plug drive](#)" on page 40).
8. Remove all hard drive blanks ("[Drive blank](#)" on page 40).
9. Disconnect all front drive cage cables.
10. Remove the front drive cage option:

- Bay 1

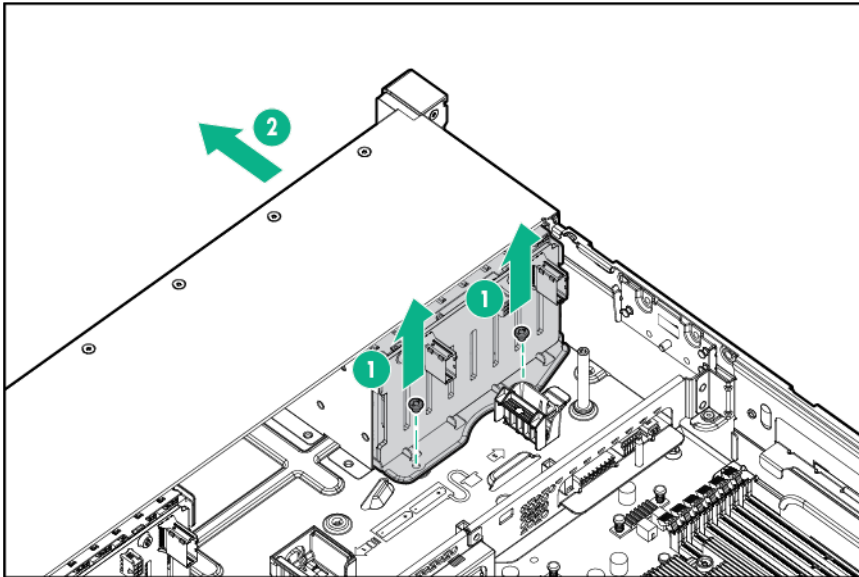

- Bay 2

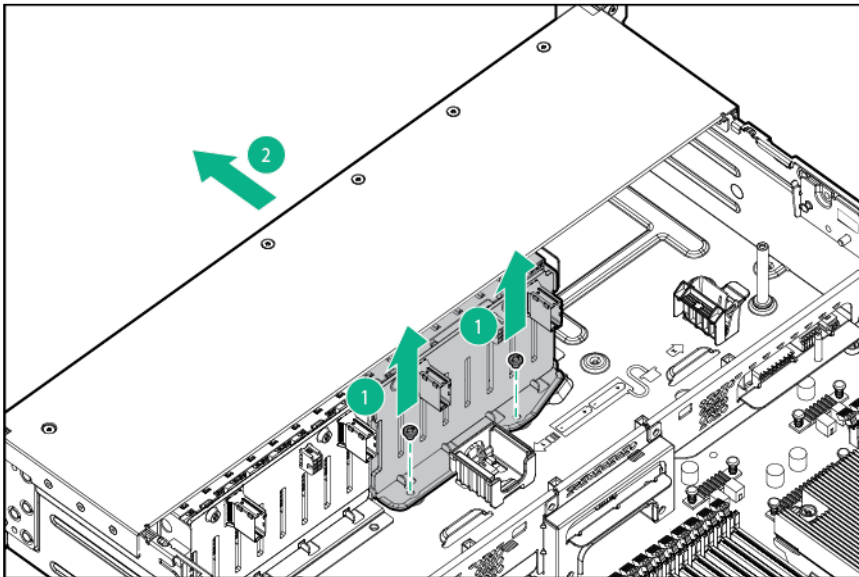

To replace the component, reverse the removal procedure.

Drive cage backplane

1. Power down the server (on page 28).
2. Remove all power:
 - a. Disconnect each power cord from the power source.
 - b. Disconnect each power cord from the server.
3. Extend the server from the rack (on page 27).
4. Remove the access panel ("[Access panel](#)" on page 31).
5. Remove the fan cage ("[Fan cage](#)" on page 39).
6. Depending on the server options installed, do one of the following:

- Remove the air baffle ("[Air baffle](#)" on page 32).
 - Remove the mezzanine tray ("[Mezzanine tray option](#)" on page 33).
7. Disconnect all cables, and then remove the backplane.

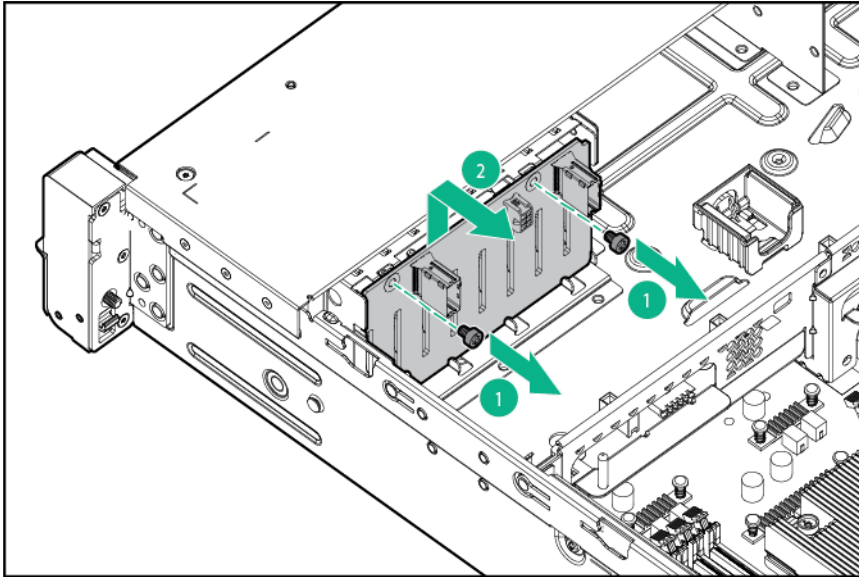

To replace the component, reverse the removal procedure.

2SFF drive cage backplane

1. Power down the server (on page 28).
2. Remove all power:
 - a. Disconnect each power cord from the power source.
 - b. Disconnect each power cord from the server.
3. Extend the server from the rack (on page 27).
4. Remove the access panel ("[Access panel](#)" on page 31).
5. Remove the fan cage ("[Fan cage](#)" on page 39).
6. Depending on the server options installed, do one of the following:
 - Remove the air baffle ("[Air baffle](#)" on page 32).
 - Remove the mezzanine tray ("[Mezzanine tray option](#)" on page 33).

7. Disconnect all cables, and then remove the backplane.

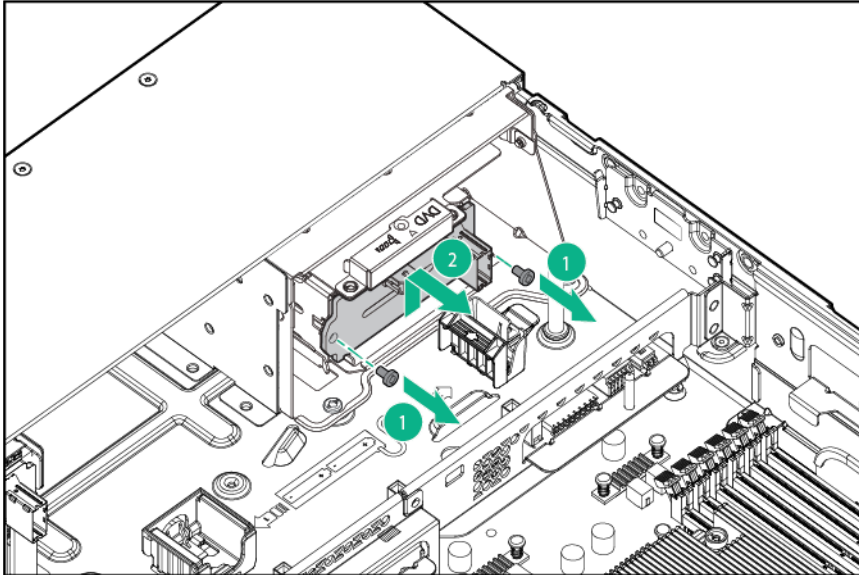

To replace the component, reverse the removal procedure.

Universal media bay

1. Power down the server (on page 28).
2. Remove all power:
 - a. Disconnect each power cord from the power source.
 - b. Disconnect each power cord from the server.
3. Extend the server from the rack (on page 27).
4. Remove the access panel ("Access panel" on page 31).
5. Remove the fan cage ("Fan cage" on page 39).
6. Depending on the server options installed, do one of the following:
 - o Remove the air baffle ("Air baffle" on page 32).
 - o Remove the mezzanine tray ("Mezzanine tray option" on page 33).

7. Disconnect the USB/VGA cables through the universal media bay opening, and then remove the universal media bay.

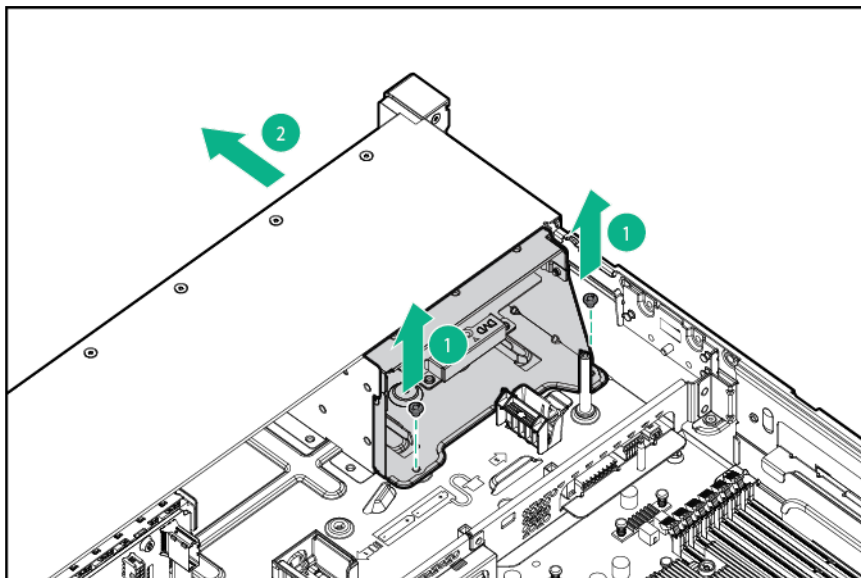

To replace the component:

1. Route the USB/VGA cables through the universal media bay opening, and then install the universal media bay.

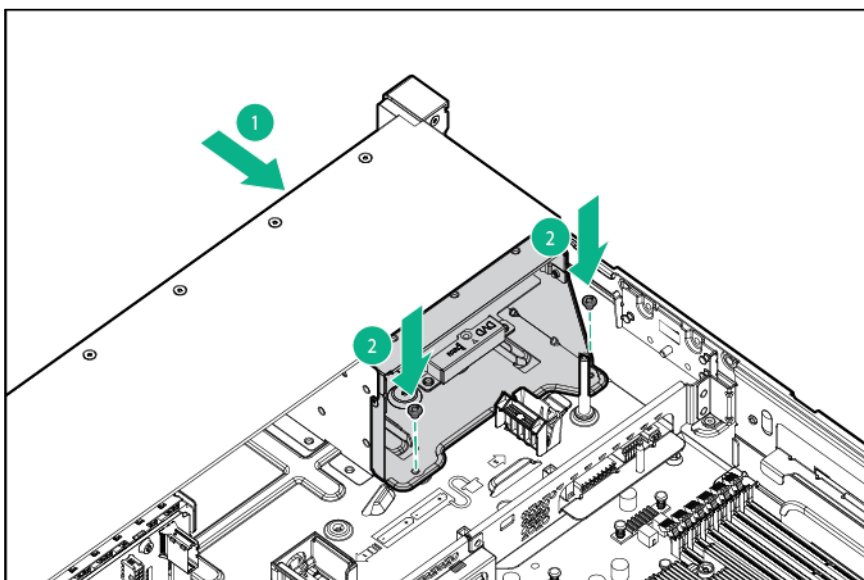

- Using the cable trough, connect the cable to the front VGA/USB 2.0 connector on the system board.

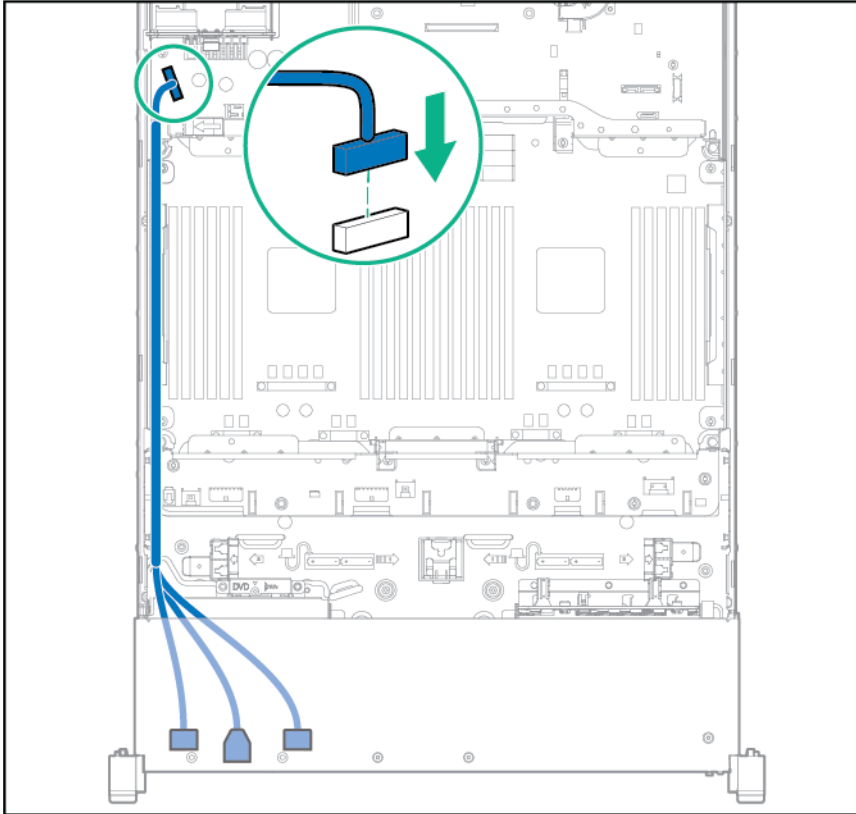

- Depending on the server options installed, do one of the following:
 - Install the air baffle ("Air baffle" on page 32).
 - Install the mezzanine tray ("Mezzanine tray option" on page 33).
- Install the fan cage ("Fan cage" on page 39).
- Install the access panel ("Access panel" on page 31).
- Slide the server into the rack.
- Connect each power cord to the server.
- Connect each power cord to the power source.
- Power up the server.

Universal media bay with two-bay SFF drive cage

- Power down the server (on page 28).
- Remove all power:
 - Disconnect each power cord from the power source.
 - Disconnect each power cord from the server.
- Extend the server from the rack (on page 27).
- Remove the access panel ("Access panel" on page 31).
- Depending on the server options installed, do one of the following:
 - Remove the air baffle ("Air baffle" on page 32).
 - Remove the mezzanine tray ("Mezzanine tray option" on page 33).
- Remove the fan cage ("Fan cage" on page 39).

7. Remove all drives ("Hot-plug drive" on page 40).
8. Disconnect the drive cage power cables.
9. Disconnect the USB/VGA through the universal media bay opening, and then remove the universal media bay.

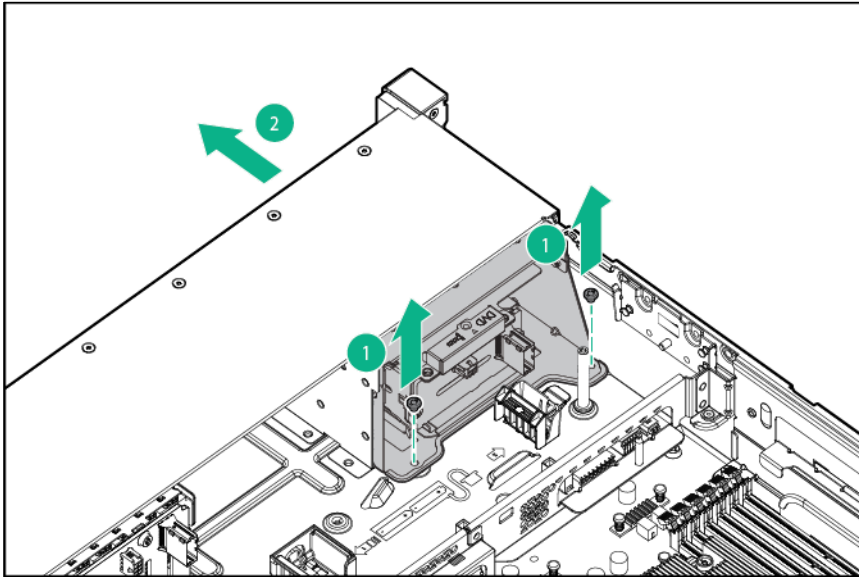

To replace the component:

1. Route the USB/VGA through the universal media bay opening, and then install the universal media bay.

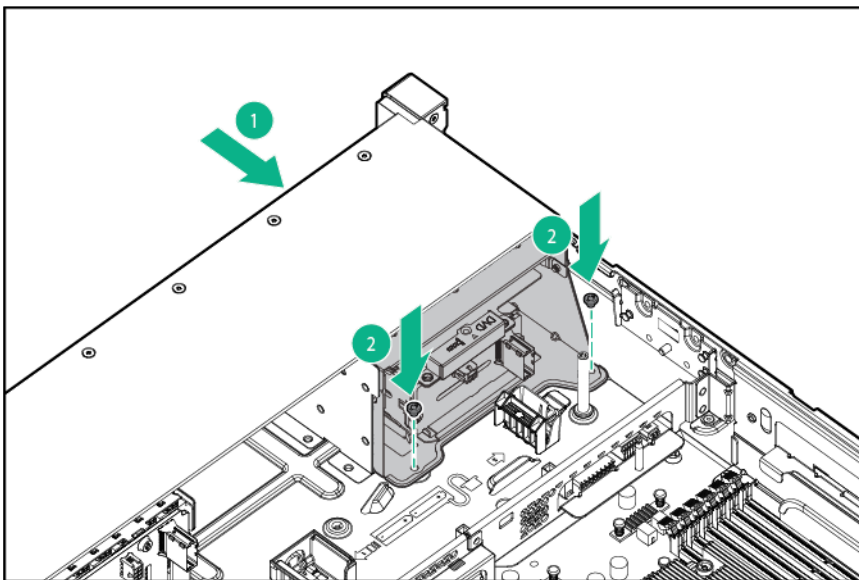

2. Connect the drive cage power cable.

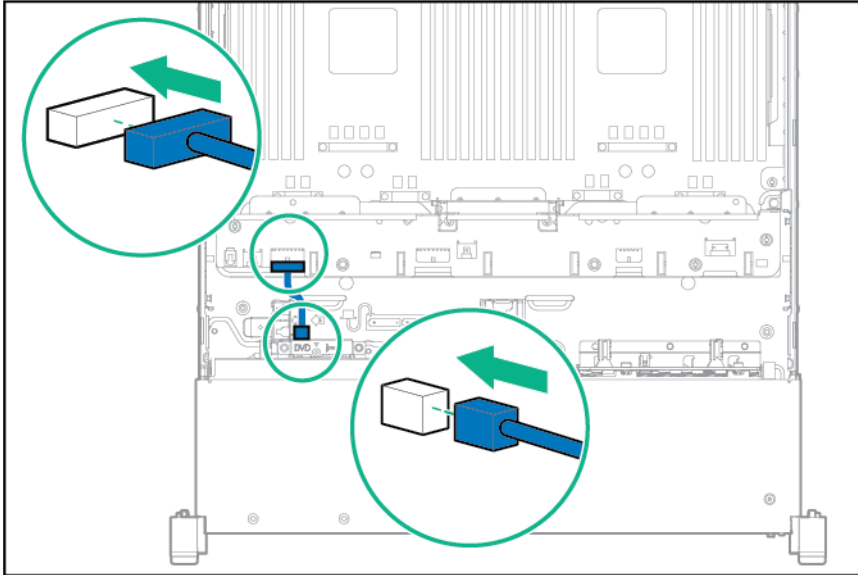

3. Use the cable trough and routing clips on the mezzanine support bracket to route the drive cage data cable.

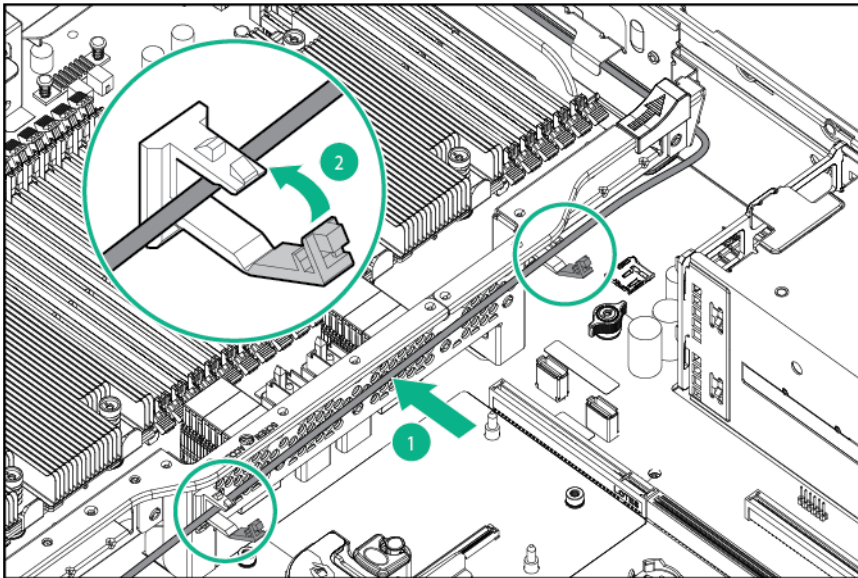

- Using the cable trough, connect the cable to the front VGA/USB 2.0 connector on the system board.

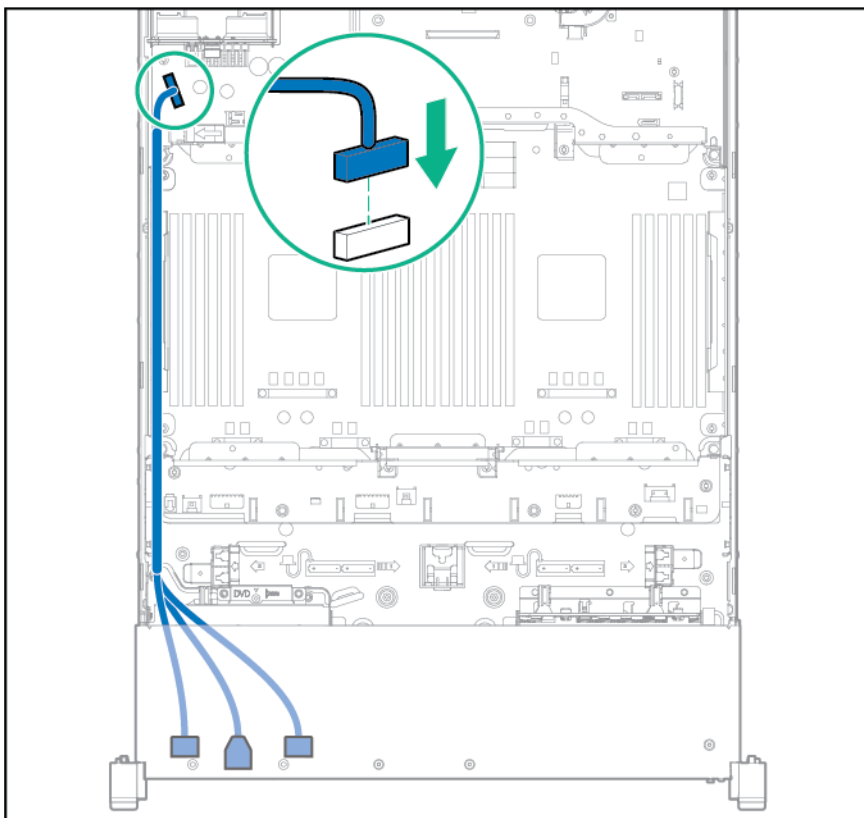

- Connect the data cable:
 - o Drive cage SAS cable:

— Configuration 1—Connecting to a controller

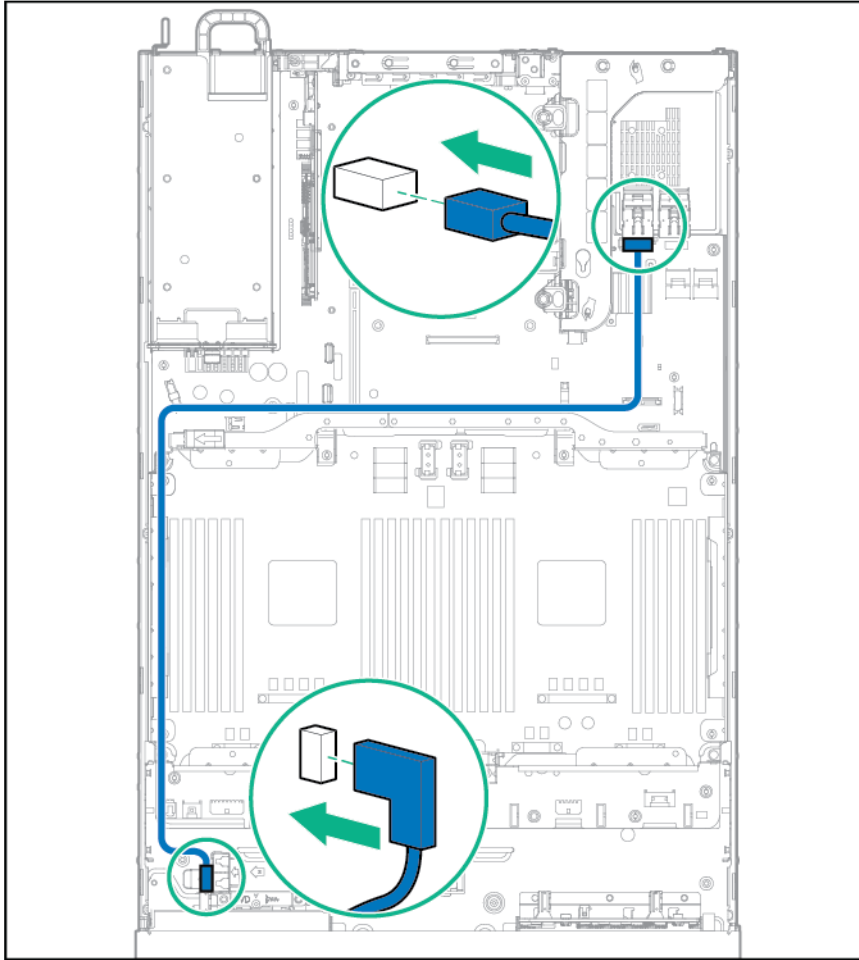

— Configuration 2—Connecting to the system board

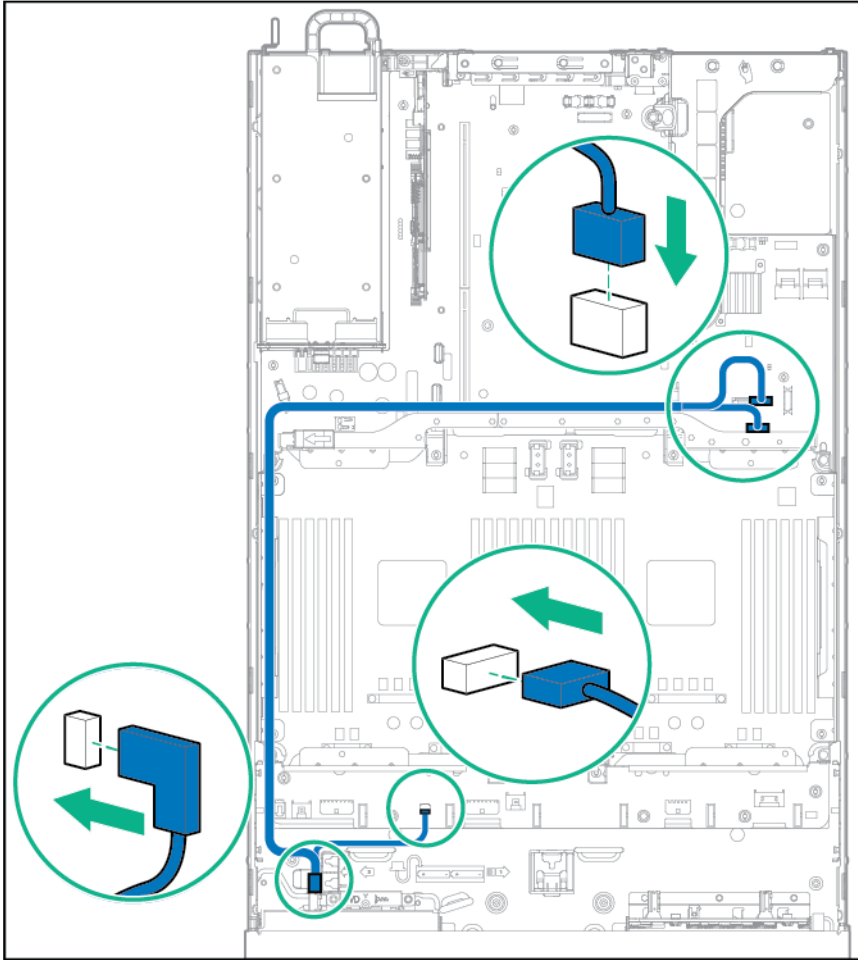

— Configuration 3—Connecting to a PCI card in slot 7

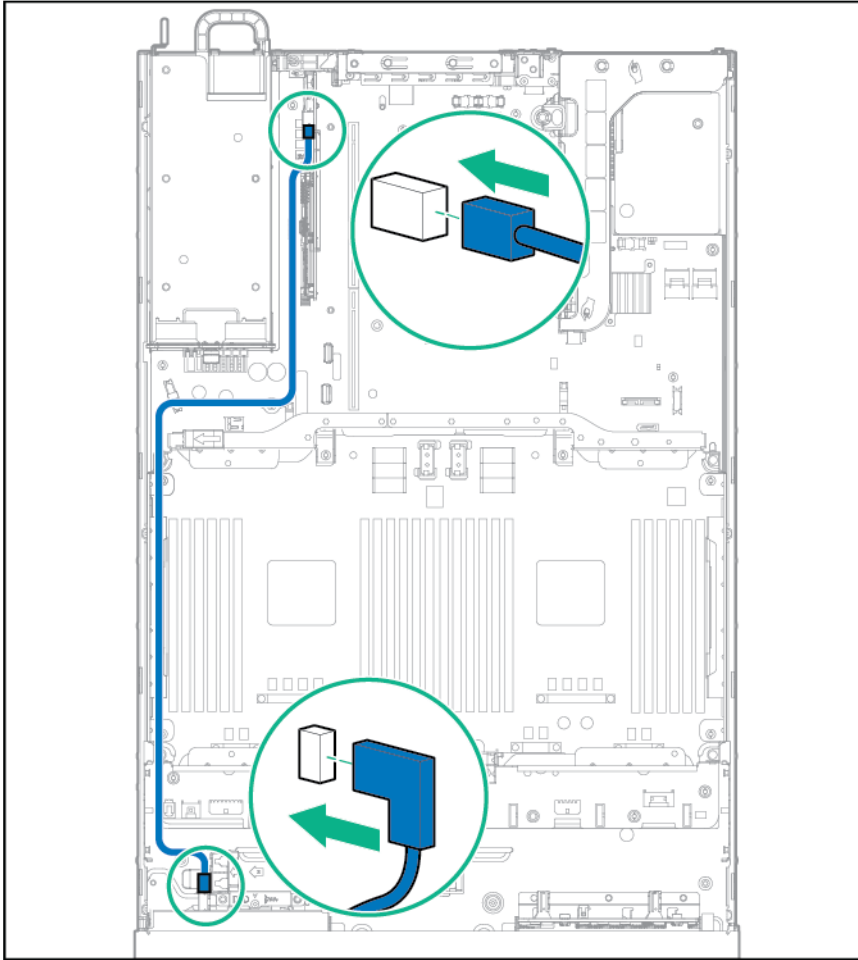

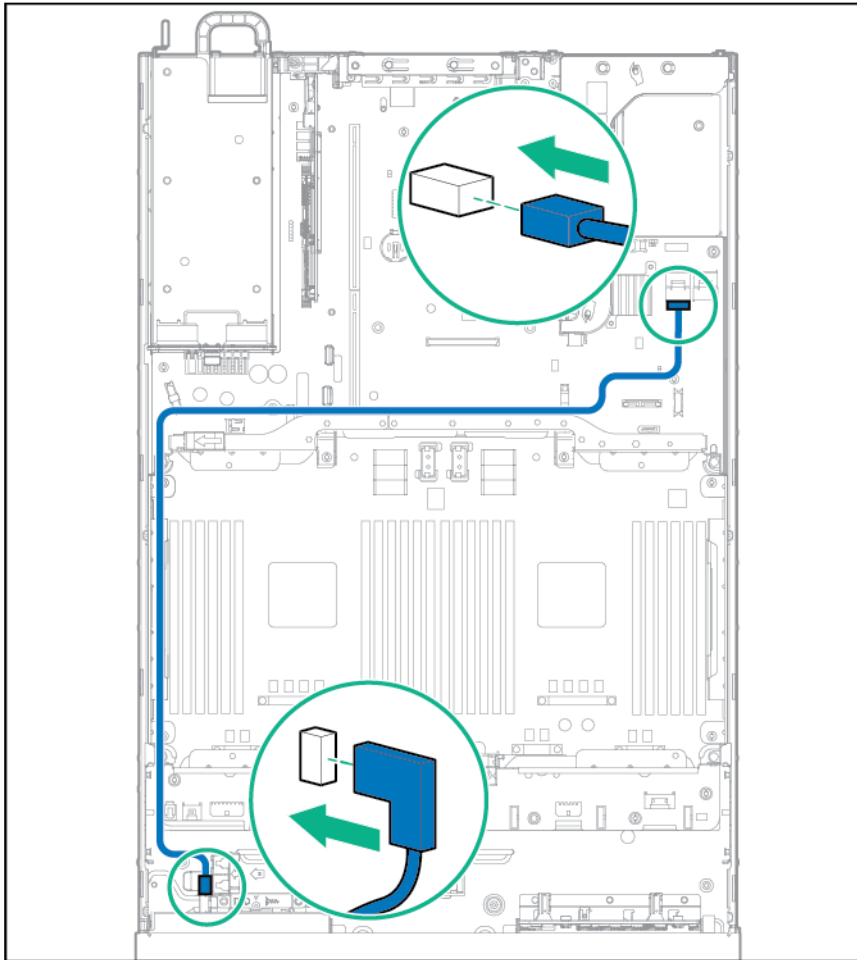

6. Install drive blanks or drives.



CAUTION: To prevent improper cooling and thermal damage, do not operate the server unless all bays are populated with either a component or a blank.

7. Install the fan cage ("Fan cage" on page 39).
8. Depending on the server options installed, do one of the following:
 - o Install the air baffle ("Air baffle" on page 32).
 - o Install the mezzanine tray ("Mezzanine tray option" on page 33).
9. Install the access panel ("Access panel" on page 31).
10. Slide the server into the rack.
11. Connect each power cord to the server.
12. Connect each power cord to the power source.
13. Power up the server.

Optical disk drive option

1. Power down the server (on page 28).
2. Remove all power:
 - a. Disconnect each power cord from the power source.

- b. Disconnect each power cord from the server.
3. Extend the server from the rack (on page 27).
4. Remove the access panel ("Access panel" on page 31).
5. Remove the fan cage ("Fan cage" on page 39).
6. Depending on the server options installed, do one of the following:
 - o Remove the air baffle ("Air baffle" on page 32).
 - o Remove the mezzanine tray ("Mezzanine tray option" on page 33).
7. Remove the universal media bay ("Universal media bay" on page 44).
8. Remove the optional optical disk drive.

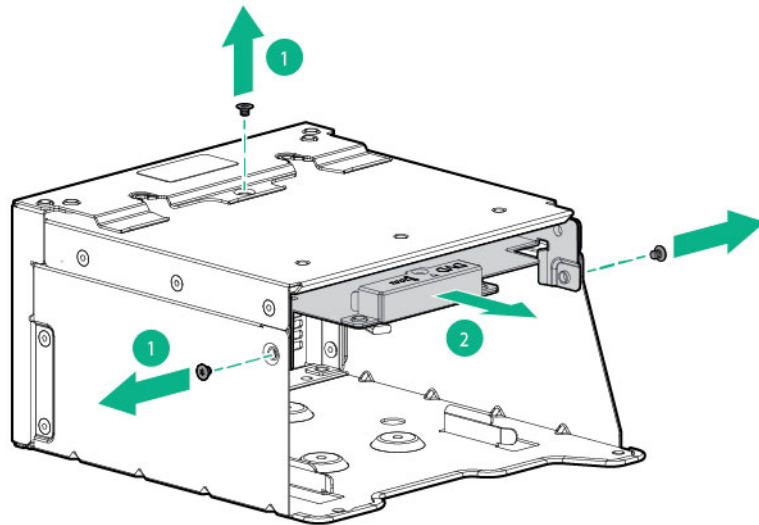

To replace the component, reverse the removal procedure.

FlexibleLOM

To remove the component:

1. Power down the server (on page 28).
2. Remove all power:
 - a. Disconnect each power cord from the power source.
 - b. Disconnect each power cord from the server.
3. Disconnect the LAN segment cables.
4. Do one of the following:
 - o Extend the server from the rack (on page 27).
 - o Remove the server from the rack (on page 28).

5. Remove the FlexibleLOM.

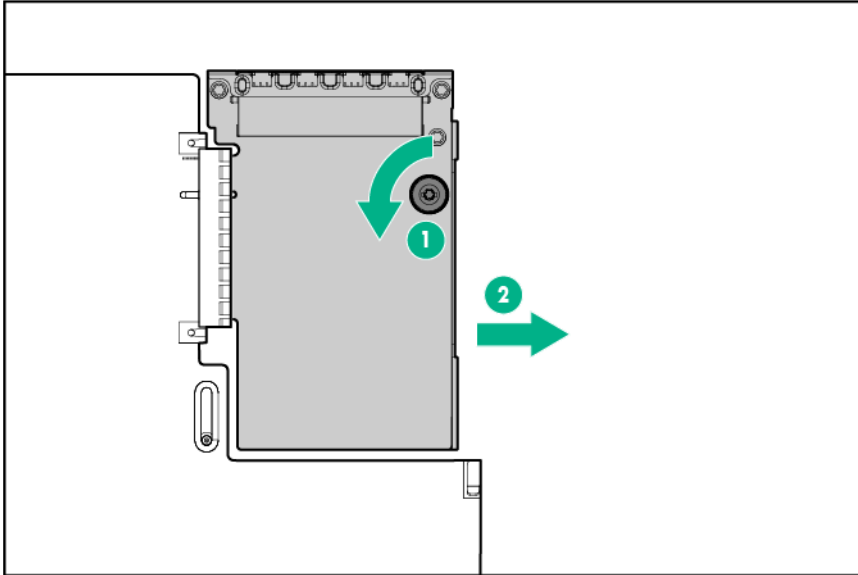

To replace the component, reverse the removal procedure.

Ear bezels

1. Power down the server (on page 28).
2. Remove all power:
 - a. Disconnect each power cord from the power source.
 - b. Disconnect each power cord from the server.
3. Extend the server from the rack (on page 27).
4. Remove the access panel ("Access panel" on page 31).
5. Remove the ear bezel.

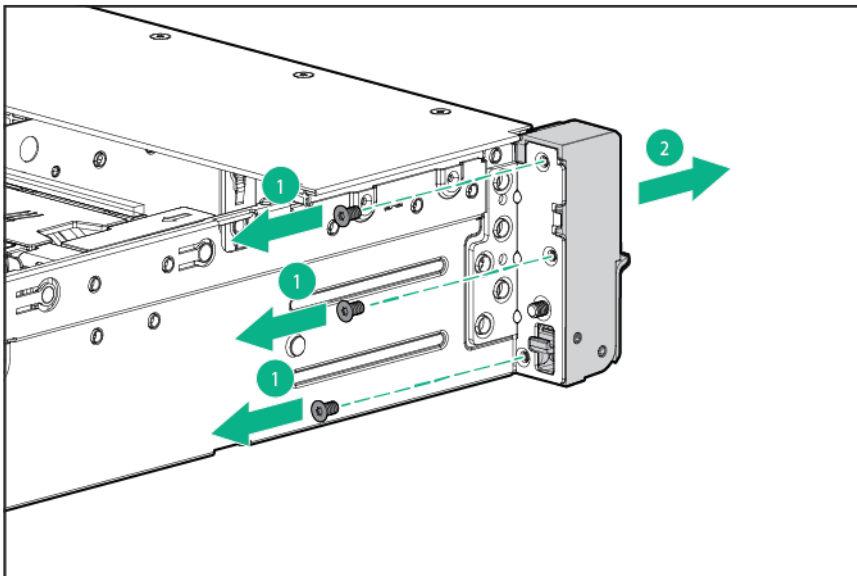

To replace the component, reverse the removal procedure.

Location Discovery Services Ear option

1. Power down the server (on page 28).
2. Remove all power:
 - a. Disconnect each power cord from the power source.
 - b. Disconnect each power cord from the server.
3. Extend the server from the rack (on page 27).
4. Remove the access panel ("Access panel" on page 31).
5. Remove the fan cage ("Fan cage" on page 39).
6. Remove the cable protection panel from the left side of the server.

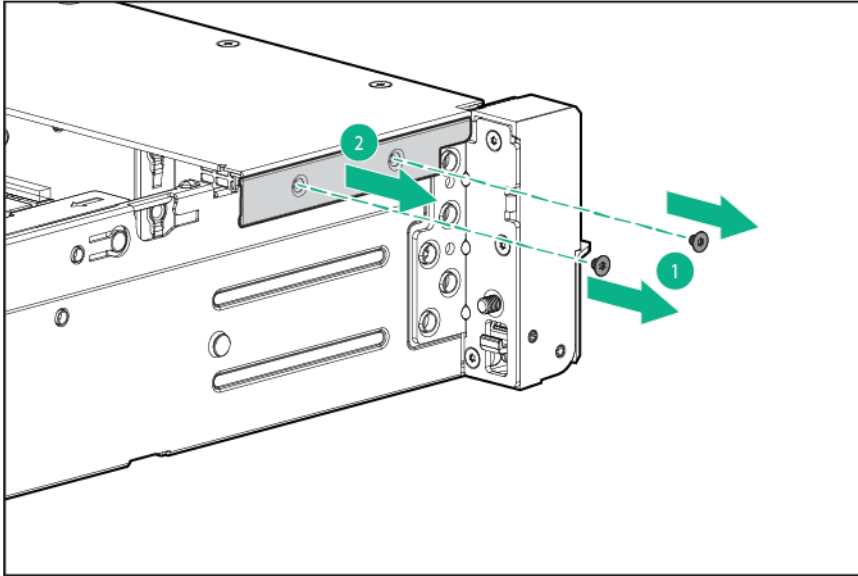

7. Disconnect the Location Discovery Services ear cable.

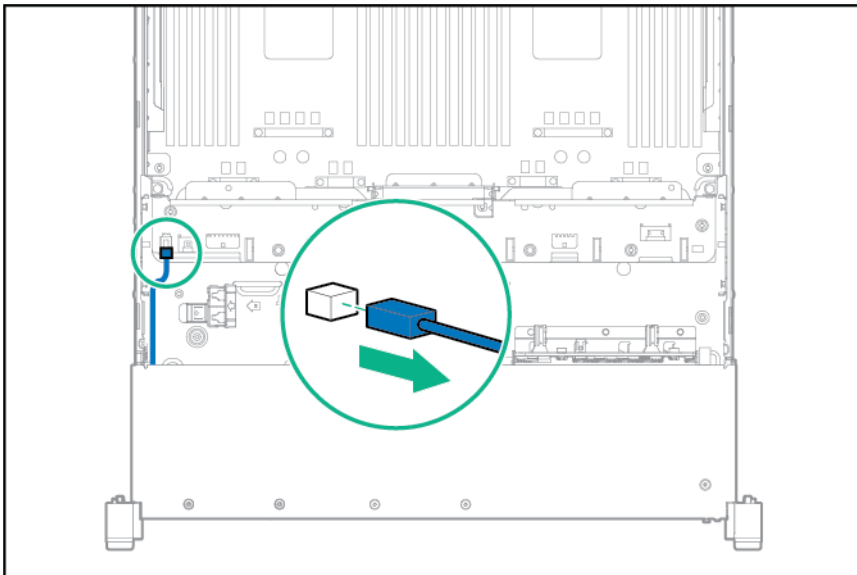

8. Remove the Location Discovery Services ear.

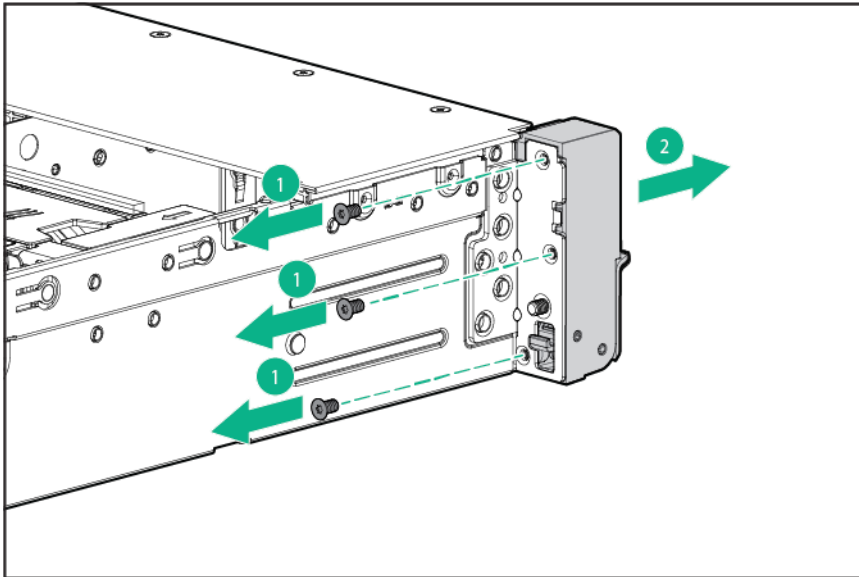

To replace the component:

1. Install the Location Discovery Services Ear option and route the Location Discovery Services cable through the side channel.

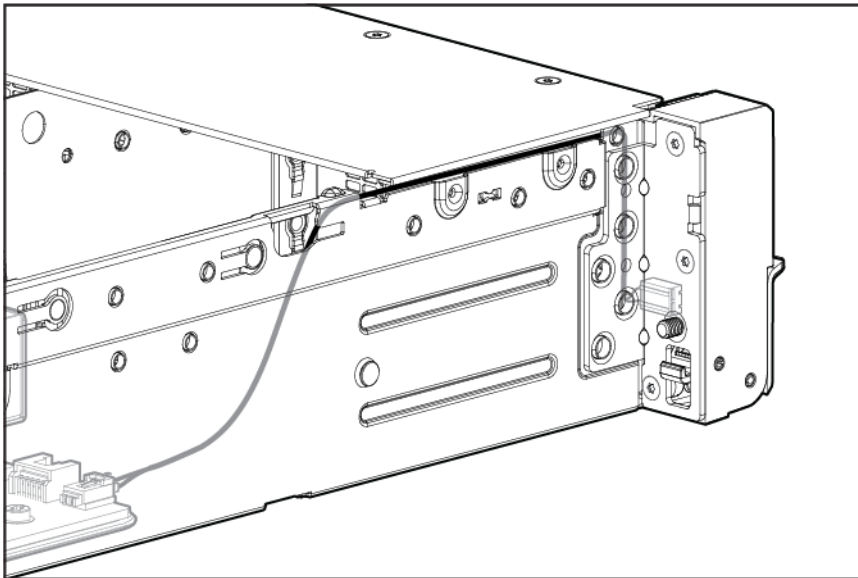
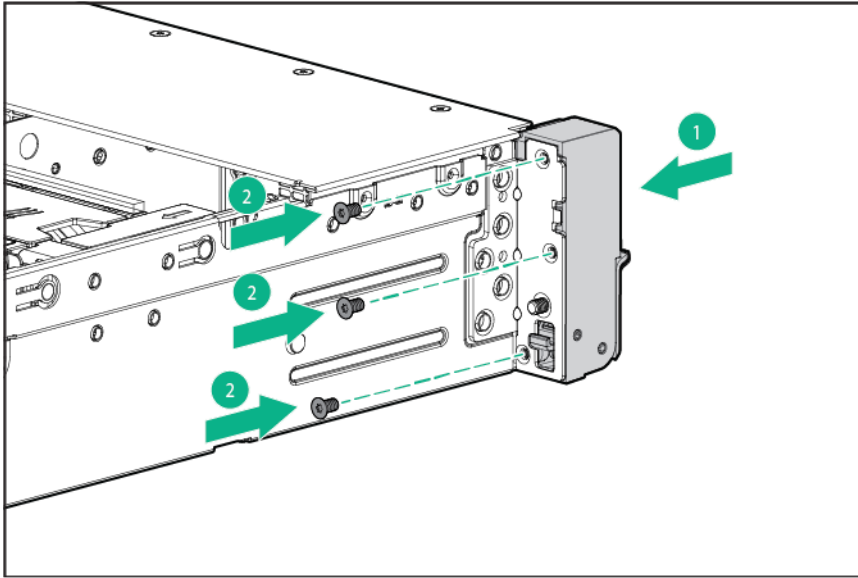

2. Install the cable protection panel.

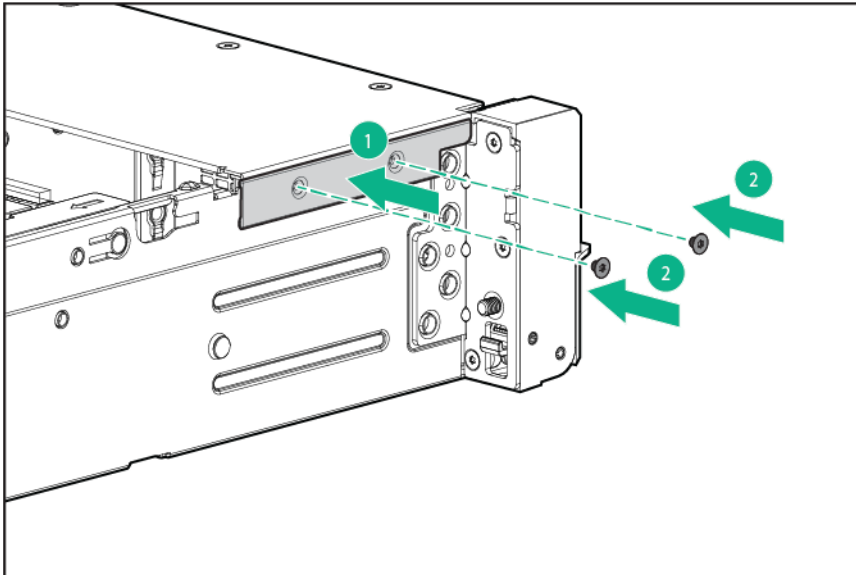

3. Connect the Location Discovery Services cable.

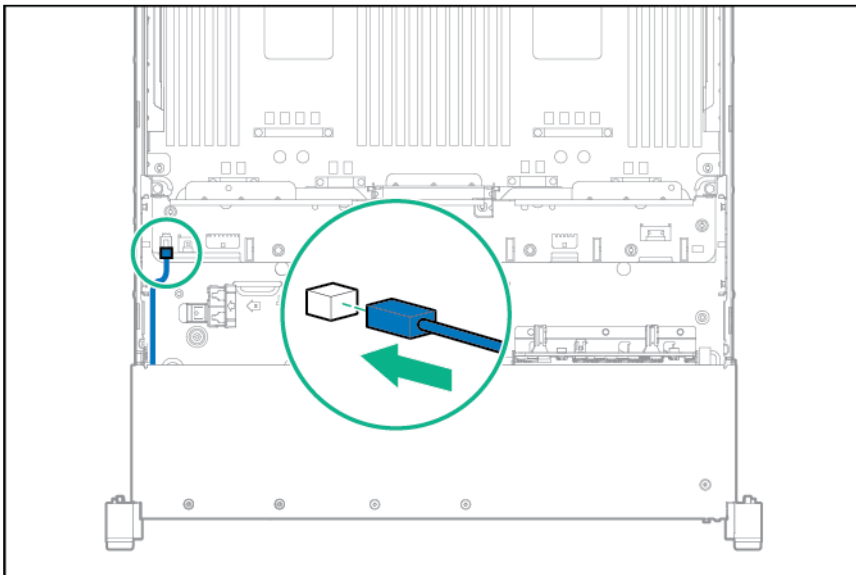

4. Install the fan cage ("Fan cage" on page 39).
5. Install the access panel ("Access panel" on page 31).
6. Slide the server into the rack.
7. Connect each power cord to the server.
8. Connect each power cord to the power source.
9. Power up the server.

Expansion slot blanks



WARNING: To reduce the risk of personal injury, electric shock, or damage to the equipment, remove the power cord to remove power from the server. The front panel Power On/Standby button does not completely shut off system power. Portions of the power supply and some internal circuitry remain active until AC power is removed.

CAUTION: For proper cooling, do not operate the server without the access panel, baffles, expansion slot covers, blanks, or the optional mezzanine tray installed. If the server supports hot-plug components, minimize the amount of time the access panel is open.

To remove the component:

1. Power down the server (on page 28).
2. Remove all power:
 - a. Disconnect each power cord from the power source.
 - b. Disconnect each power cord from the server.
3. Extend the server from the rack (on page 27).
4. Remove the access panel ("Access panel" on page 31).
5. Remove the primary PCIe riser cage ("Primary 3-slot PCI riser cage" on page 33).
6. Remove the expansion slot blank.

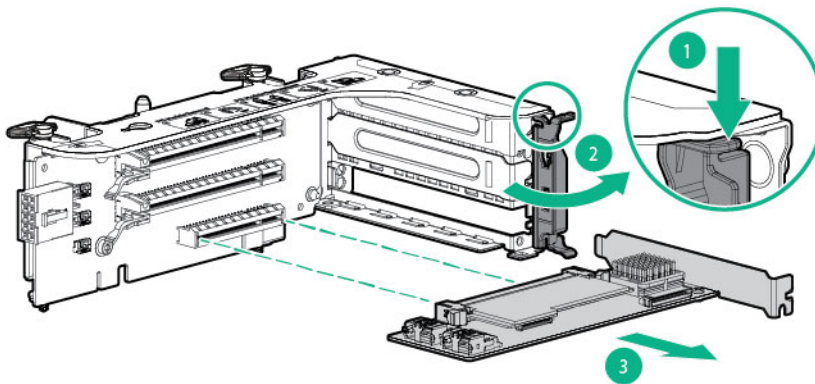

To replace the component, reverse the removal procedure.

Expansion boards

Half-length expansion board

WARNING: To reduce the risk of personal injury, electric shock, or damage to the equipment, remove the power cord to remove power from the server. The front panel Power On/Standby button does not completely shut off system power. Portions of the power supply and some internal circuitry remain active until AC power is removed.

To remove the component:

1. Power down the server (on page 28).
2. Remove all power:
 - a. Disconnect each power cord from the power source.
 - b. Disconnect each power cord from the server.
3. Extend the server from the rack (on page 27).
4. Remove the access panel ("Access panel" on page 31).
5. Disconnect any external cables that are connected to the expansion board.
6. Disconnect any internal cables that are connected to the expansion board.
7. Remove the PCIe riser cage ("Primary 3-slot PCI riser cage" on page 33).

8. Remove the expansion board.

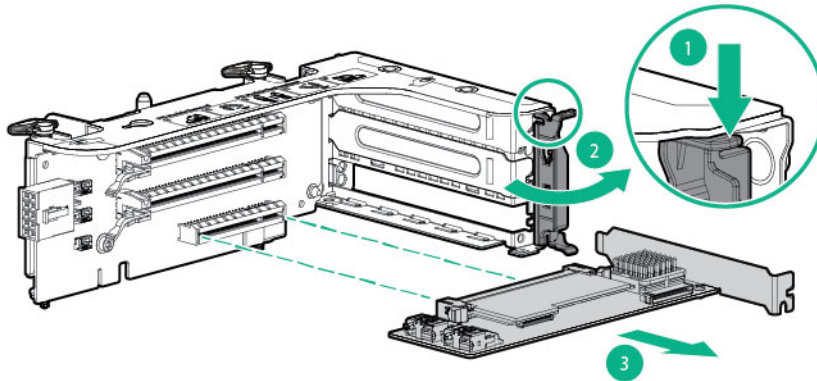

To replace the component, reverse the removal procedure.

SAS expander card option

1. Power down the server (on page 28).
2. Remove all power:
 - a. Disconnect each power cord from the power source.
 - b. Disconnect each power cord from the server.
3. Extend the server from the rack (on page 27).
4. Remove the access panel ("[Access panel](#)" on page 31).
5. Depending on the server options installed, do one of the following:
 - o Remove the air baffle ("[Air baffle](#)" on page 32).
 - o Remove the mezzanine tray ("[Mezzanine tray option](#)" on page 33).
6. Remove the fan cage ("[Fan cage](#)" on page 39).
7. Remove the primary PCI riser cage ("[Primary 3-slot PCI riser cage](#)" on page 33).
8. Disconnect the cables from the expander card.
9. Remove the expander card.

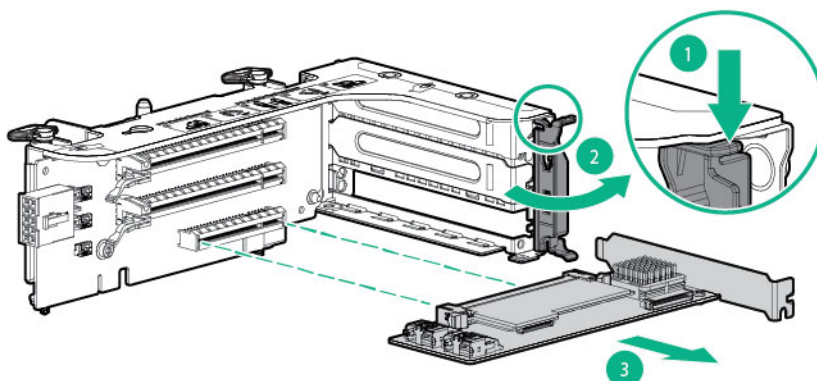

To replace the component:

1. Remove the primary PCI riser cage ("[Primary 3-slot PCI riser cage](#)" on page 33).



IMPORTANT: The 12G SAS Expander Card is not supported in the secondary PCI riser cage.

2. Install the SAS expander card. The cables are not shown for clarity.



IMPORTANT: The 12G SAS Expander Card is only supported in slot 2.

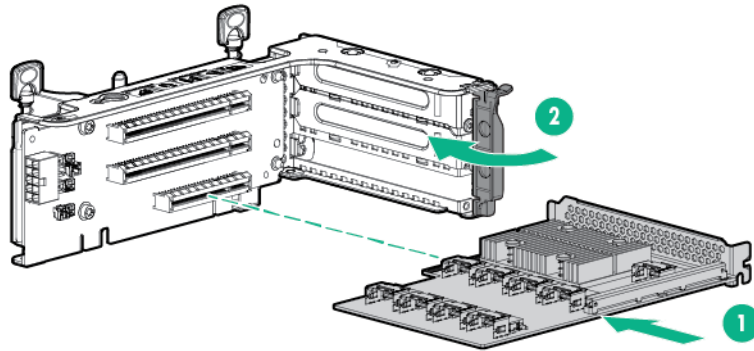

IMPORTANT: If using a PCI slot-based controller, install the controller in slot 1.

3. Install the PCI riser cage.
4. Using the labels on the cables to determine the correct connections, connect the cables from the SAS expander card to the controller:
 - o HPE Flexible Smart Array Controller with 2 x4 connectors (Group B SAS cables)

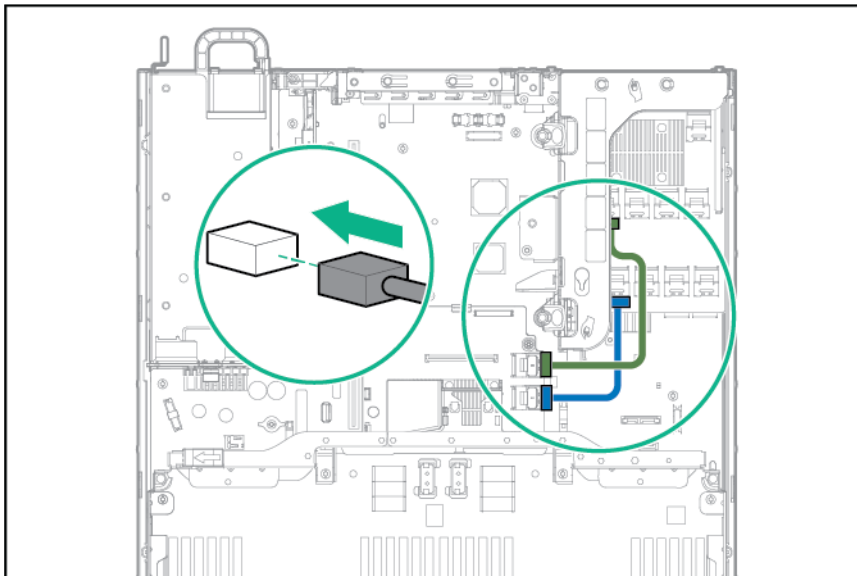

- o PCI slot-based Smart Array controller with x8 connector (Group A SAS cables)

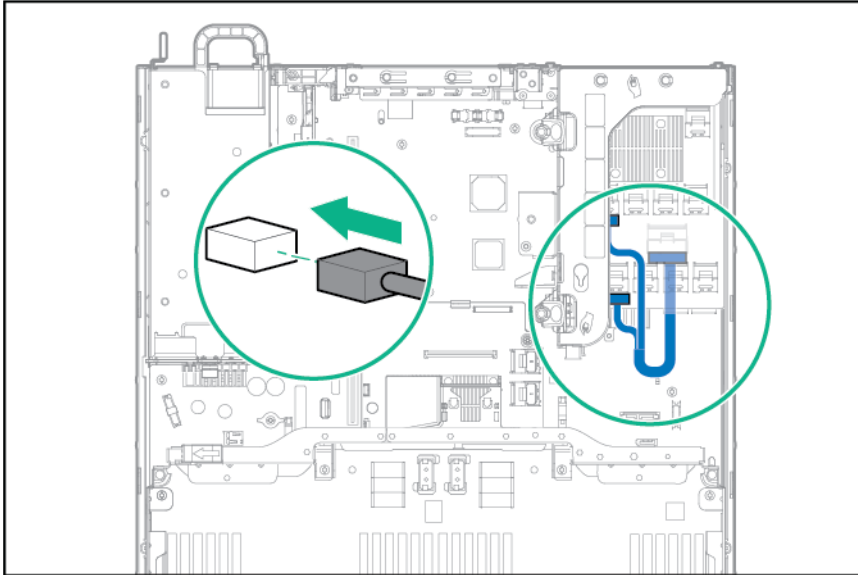

5. Connect the cables to the drive cage backplanes:



IMPORTANT: You might need to remove the far right DIMM to route cables through the cable trough. After the cables have been routed, install the DIMM.

- o 24SFF backplanes (Group C SAS cables)

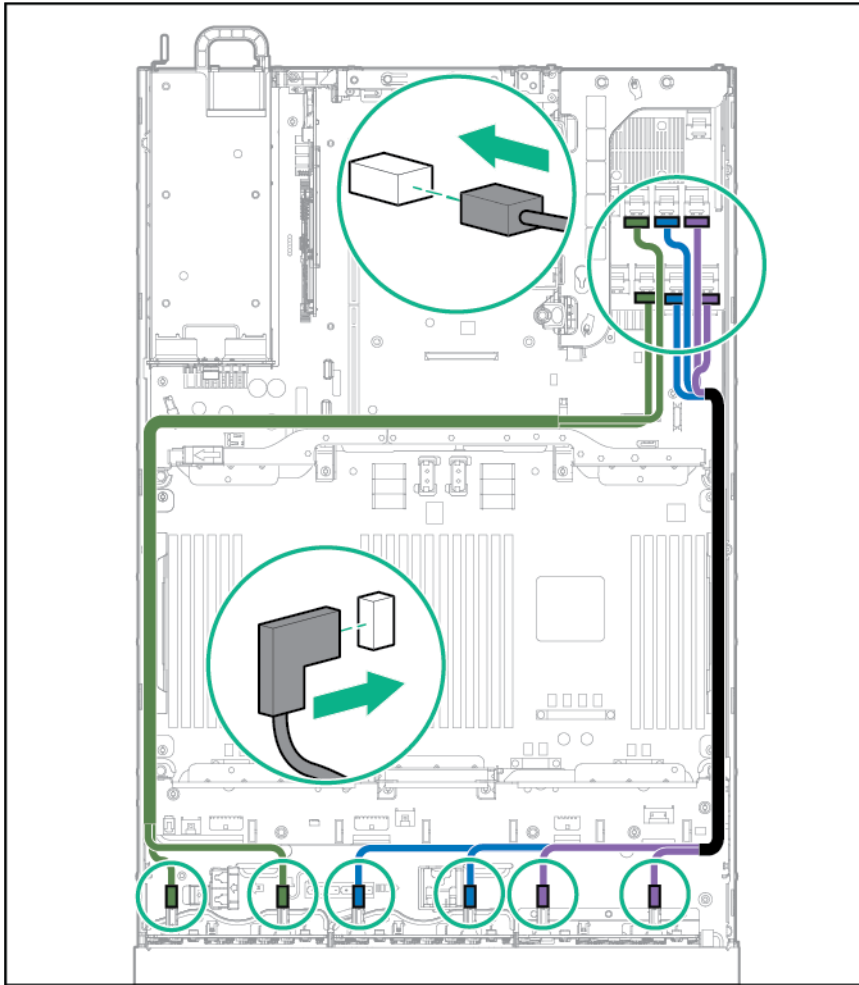

- o 18SFF backplanes (Group C SAS cables)

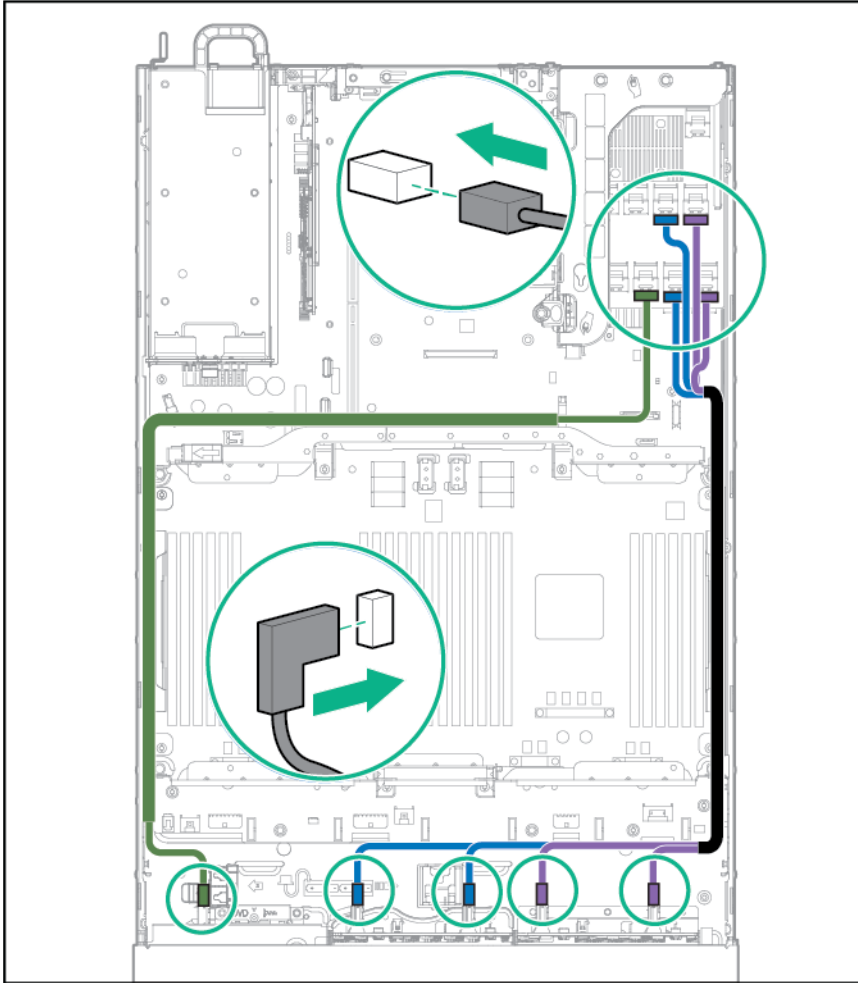

- 16SFF backplanes (Group C SAS cables)

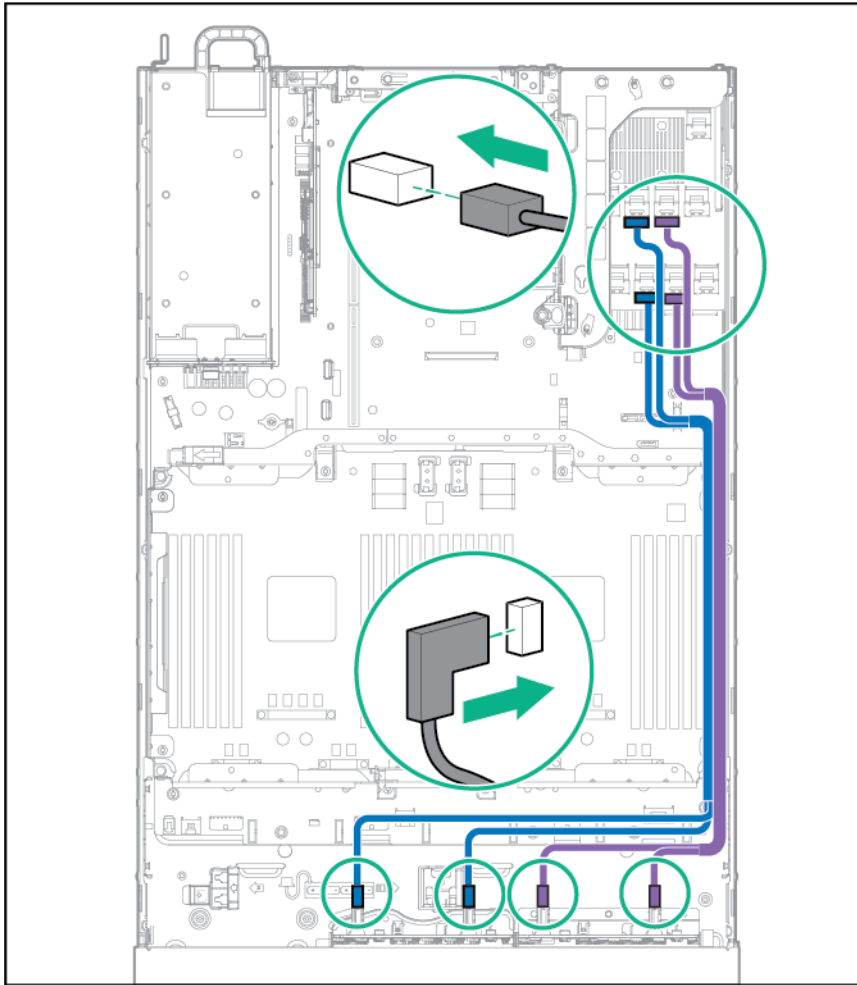

6. Install the fan cage ("Fan cage" on page 39).
7. Depending on the server options installed, do one of the following:
 - Install the air baffle ("Air baffle" on page 32).
 - Install the mezzanine tray ("Mezzanine tray option" on page 33).
8. Install the access panel ("Access panel" on page 31).
9. Install the server into the rack.
10. Connect each power cord to the server.
11. Connect each power cord to the power source.
12. Power up the server.

To replace the component, reverse the removal procedure.

AROC controller

- △ **CAUTION:** Hewlett Packard Enterprise recommends performing a complete backup of all server data before performing a controller or adapter installation or removal.
- △ **CAUTION:** In systems that use external data storage, be sure that the server is the first unit to be powered down and the last to be powered back up. Taking this precaution ensures that the system does not erroneously mark the drives as failed when the server is powered up.

To remove the component:

1. Power down the server (on page 28).
2. Remove all power:
 - a. Disconnect each power cord from the power source.
 - b. Disconnect each power cord from the server.
3. Extend the server from the rack (on page 27).
4. Remove the access panel ("Access panel" on page 31).
5. Remove the fan cage ("Fan cage" on page 39).
6. Depending on the server options installed, do one of the following:
 - o Remove the air baffle ("Air baffle" on page 32).
 - o Remove the mezzanine tray ("Mezzanine tray option" on page 33).
7. Remove the controller.

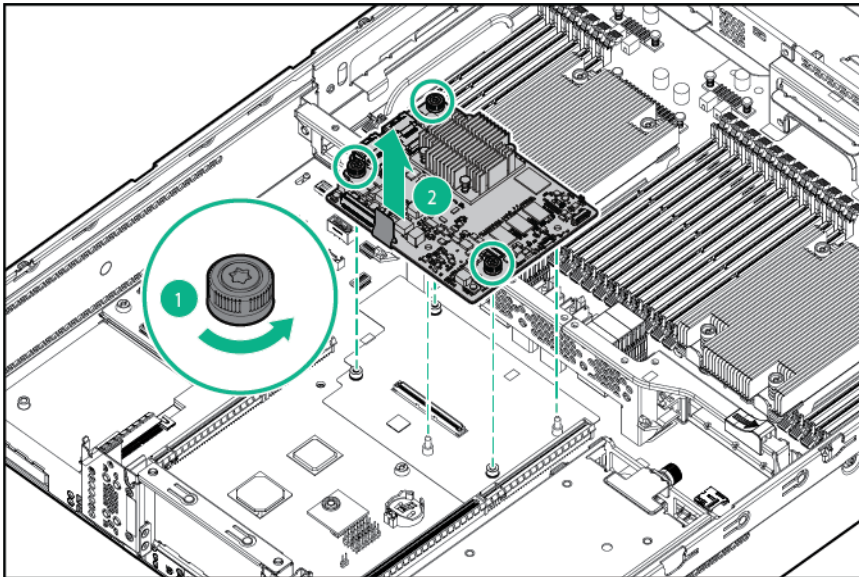

To replace the component, reverse the removal procedure.

Power supply backplane

⚠ WARNING: To reduce the risk of personal injury, electric shock, or damage to the equipment, remove the power cord to remove power from the server. The front panel Power On/Standby button does not completely shut off system power. Portions of the power supply and some internal circuitry remain active until AC power is removed.

To remove the component:

1. Power down the server (on page 28).
2. Remove all power:
 - a. Disconnect each power cord from the power source.
 - b. Disconnect each power cord from the server.
3. Remove all power supplies ("AC power supply" on page 76).
4. Extend the server from the rack (on page 27).
5. Remove the access panel ("Access panel" on page 31).

6. Remove the power supply backplane.

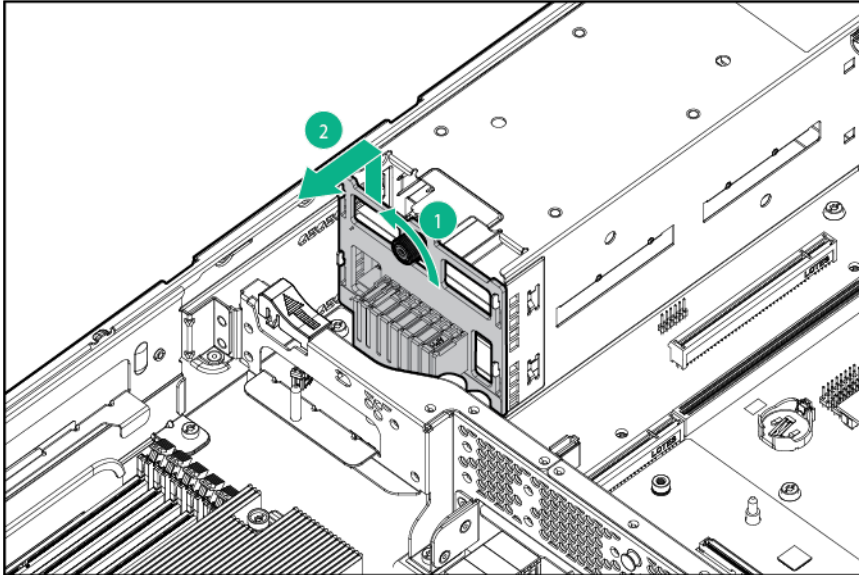

To replace the component, reverse the removal procedure.

DIMMs



WARNING: To reduce the risk of personal injury, electric shock, or damage to the equipment, remove the power cord to remove power from the server. The front panel Power On/Standby button does not completely shut off system power. Portions of the power supply and some internal circuitry remain active until AC power is removed.



IMPORTANT: This server does not support mixing RDIMMs and UDIMMs. Attempting to mix these two types causes the server to halt during BIOS initialization.

To identify the DIMMs installed in the server, see "DIMM slot locations (on page 102)."

To remove the component:

1. Power down the server (on page 28).
2. Remove all power:
 - a. Disconnect each power cord from the power source.
 - b. Disconnect each power cord from the server.
3. Extend the server from the rack (on page 27).
4. Remove the access panel ("Access panel" on page 31).
5. Depending on the server options installed, do one of the following:
 - o Remove the air baffle ("Air baffle" on page 32).
 - o Remove the mezzanine tray ("Mezzanine tray option" on page 33).

6. Remove the DIMM.

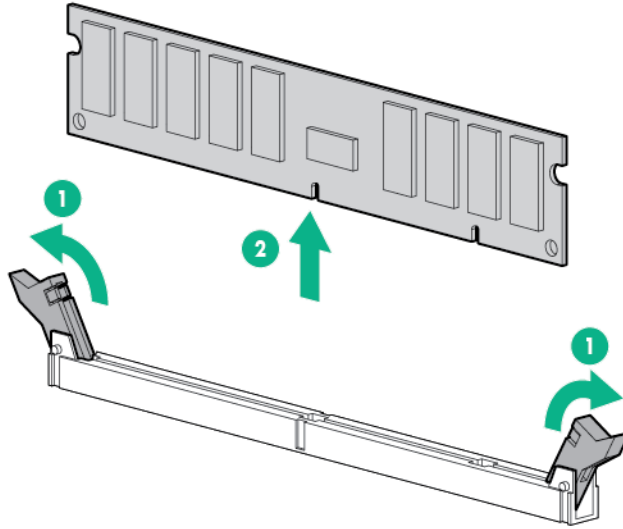

To replace the component, reverse the removal procedure.

For DIMM configuration information, see the server user guide.

HPE Smart Storage Battery

1. Power down the server (on page 28).
2. Remove all power:
 - a. Disconnect each power cord from the power source.
 - b. Disconnect each power cord from the server.
3. Extend the server from the rack (on page 27).
4. Remove the access panel ("[Access panel](#)" on page 31).
5. Remove the fan cage ("[Fan cage](#)" on page 39).
6. Disconnect the battery cable.

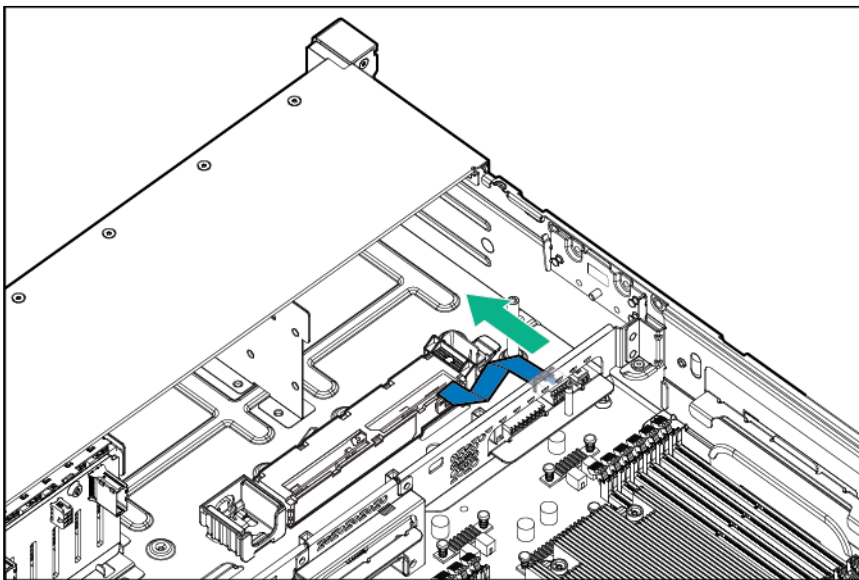

7. Remove the HPE Smart Storage battery.

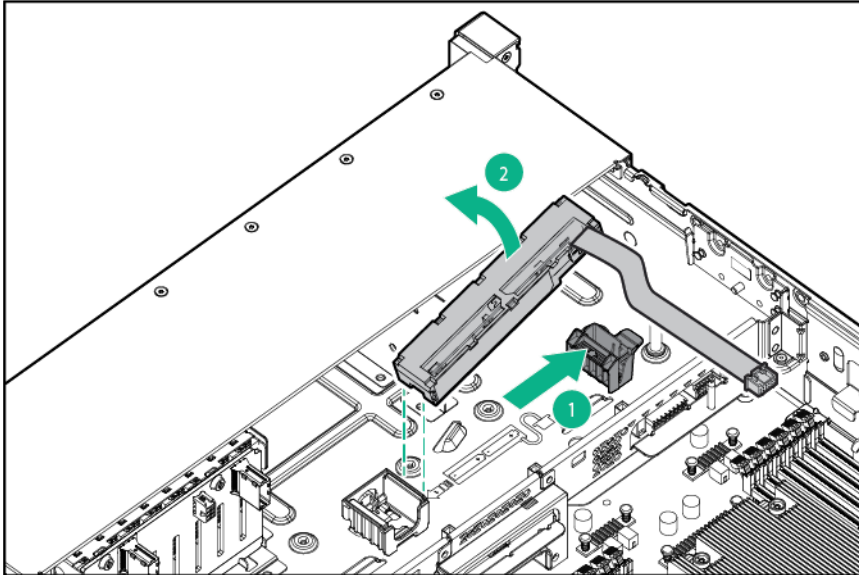

To replace the component, reverse the removal procedure.

Heatsink

-
- ⚠ **WARNING:** To reduce the risk of personal injury from hot surfaces, allow the drives and the internal system components to cool before touching them.
-
- ⚠ **WARNING:** To reduce the risk of personal injury, electric shock, or damage to the equipment, remove the power cord to remove power from the server. The front panel Power On/Standby button does not completely shut off system power. Portions of the power supply and some internal circuitry remain active until AC power is removed.
-
- ⚠ **CAUTION:** The heatsink thermal interface media is not reusable and must be replaced if the heatsink is removed from the processor after it has been installed.
-

To remove the component:

1. Power down the server (on page 28).
2. Remove all power:
 - a. Disconnect each power cord from the power source.
 - b. Disconnect each power cord from the server.
3. Extend the server from the rack (on page 27).
4. Remove the access panel ("Access panel" on page 31).
5. Depending on the server options installed, do one of the following:
 - Remove the air baffle ("Air baffle" on page 32).
 - Remove the mezzanine tray ("Mezzanine tray option" on page 33).

6. Remove the heatsink.

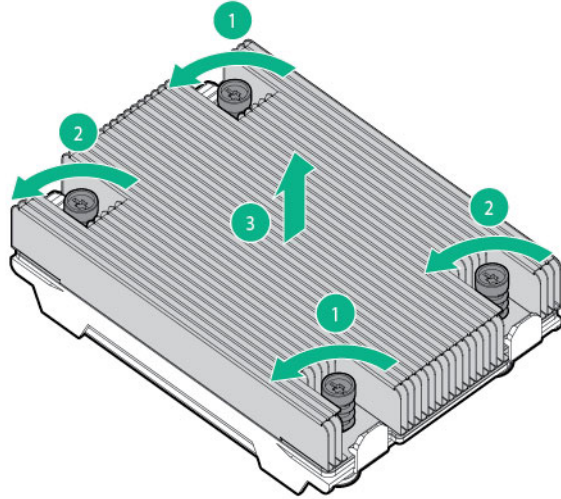

To replace the component:

1. Remove the thermal interface protective cover from the heatsink.

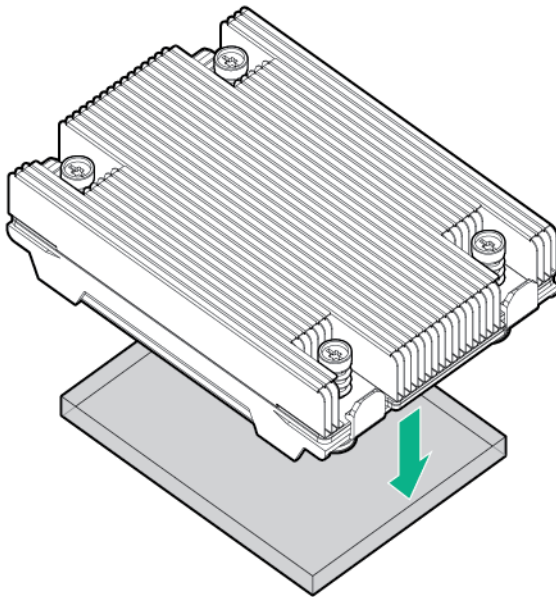

2. Install the heatsink.

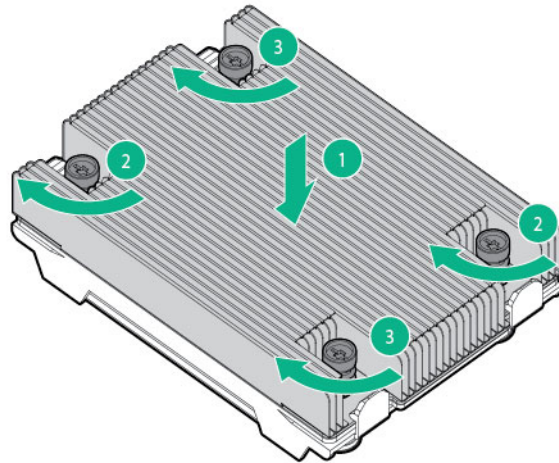

3. Depending on the server options installed, do one of the following:
 - o Install the air baffle ("Air baffle" on page 32).
 - o Install the mezzanine tray ("Mezzanine tray option" on page 33).
4. Install the access panel ("Access panel" on page 31).
5. Slide the server into the rack.
6. Connect each power cord to the server.
7. Connect each power cord to the power source.
8. Power up the server.

Processor

-
- WARNING:** To reduce the risk of personal injury from hot surfaces, allow the drives and the internal system components to cool before touching them.
-
- WARNING:** To reduce the risk of personal injury, electric shock, or damage to the equipment, remove the power cord to remove power from the server. The front panel Power On/Standby button does not completely shut off system power. Portions of the power supply and some internal circuitry remain active until AC power is removed.
-
- CAUTION:** To prevent possible server malfunction and damage to the equipment, multiprocessor configurations must contain processors with the same part number.
-
- CAUTION:** The heatsink thermal interface media is not reusable and must be replaced if the heatsink is removed from the processor after it has been installed.
-
- CAUTION:** To prevent possible server overheating, always populate processor socket 2 with a processor and a heatsink or a processor socket cover and a heatsink blank.
-
- IMPORTANT:** Processor socket 1 must be populated at all times or the server does not function.
-

To remove the component:

1. Power down the server (on page 28).
2. Remove all power:
 - a. Disconnect each power cord from the power source.
 - b. Disconnect each power cord from the server.
3. Extend the server from the rack (on page 27).
4. Remove the access panel ("Access panel" on page 31).
5. Depending on the server options installed, do one of the following:
 - o Remove the air baffle ("Air baffle" on page 32).
 - o Remove the mezzanine tray ("Mezzanine tray option" on page 33).
6. Remove the heatsink ("Heatsink" on page 70).
7. Open each of the processor locking levers in the order indicated, and then open the processor retaining bracket.

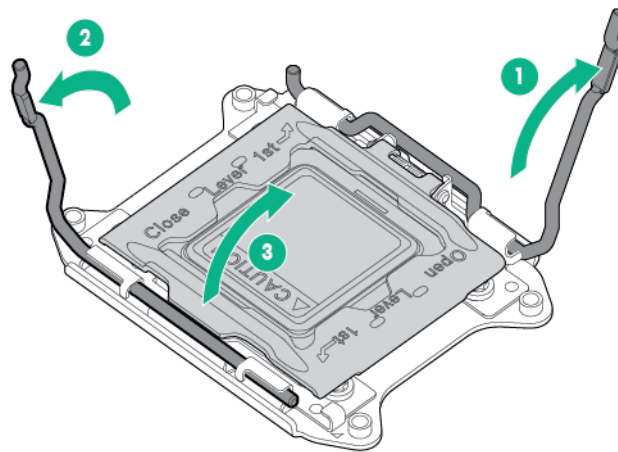

8. Remove the processor from the processor retaining bracket.

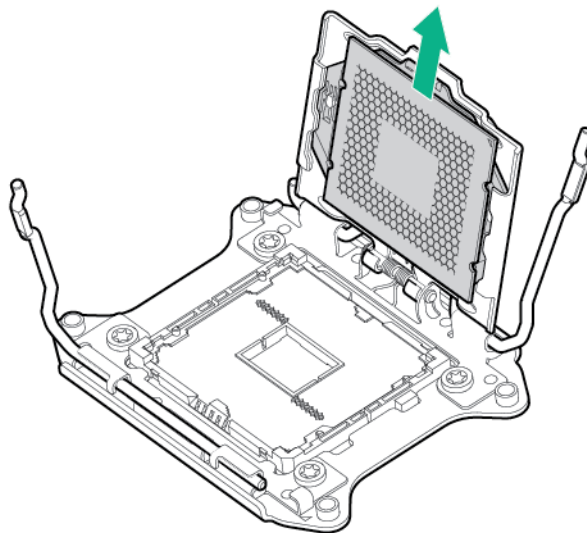

-
- △ **CAUTION:** To avoid damage to the processor, do not touch the bottom of the processor, especially the contact area.
-

To replace the component:

1. Install the processor. Verify that the processor is fully seated in the processor retaining bracket by visually inspecting the processor installation guides on either side of the processor. **THE PINS ON THE SYSTEM BOARD ARE VERY FRAGILE AND EASILY DAMAGED.**

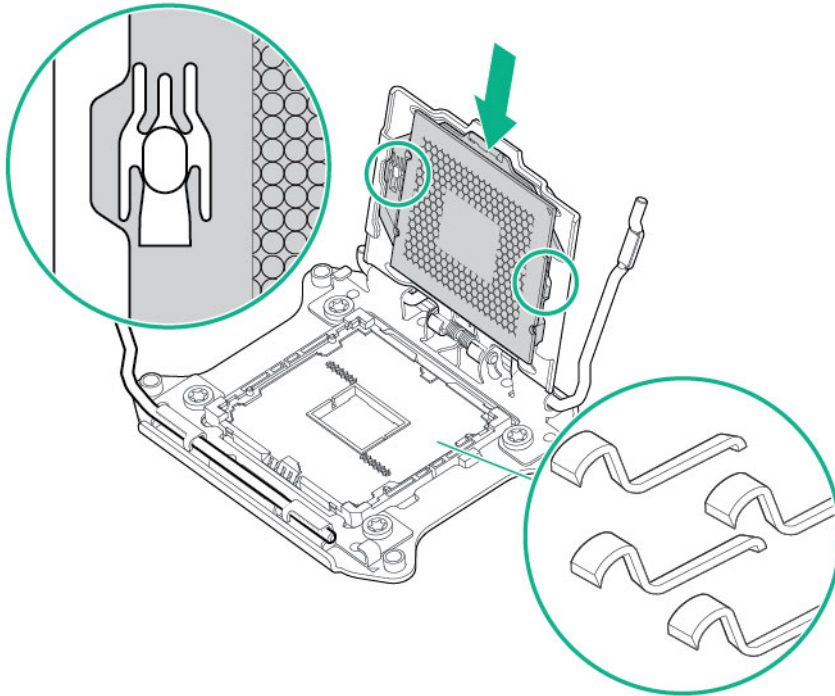

-
- △ **CAUTION: THE PINS ON THE SYSTEM BOARD ARE VERY FRAGILE AND EASILY DAMAGED.** To avoid damage to the system board, do not touch the processor or the processor socket contacts.
-

2. Close the processor retaining bracket. When the processor is installed properly inside the processor retaining bracket, the processor retaining bracket clears the flange on the front of the socket.

- △ **CAUTION:** Do not press down on the processor. Pressing down on the processor may cause damage to the processor socket and the system board. Press only in the area indicated on the processor retaining bracket.
-

3. Press and hold the processor retaining bracket in place, and then close each processor locking lever. Press only in the area indicated on the processor retaining bracket.

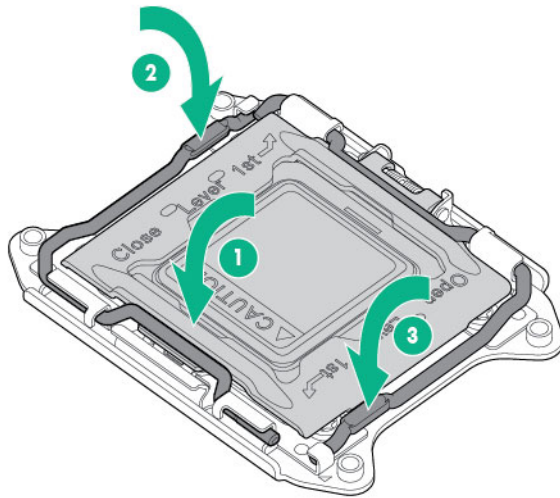

4. Install the heatsink.

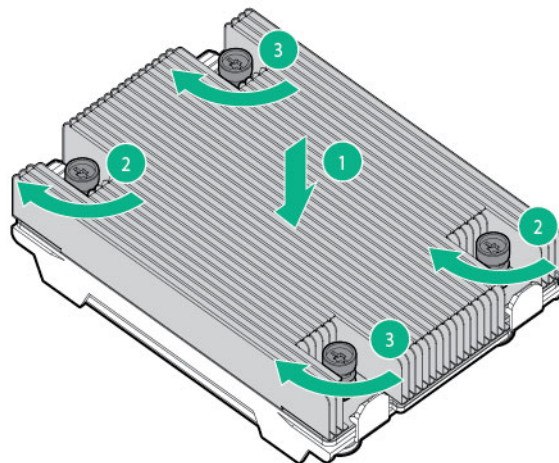

5. Depending on the server options installed, do one of the following:
 - Install the air baffle ("[Air baffle](#)" on page 32).
 - Install the mezzanine tray ("[Mezzanine tray option](#)" on page 33).
6. Install the access panel ("[Access panel](#)" on page 31).
7. Slide the server into the rack.
8. Connect each power cord to the server.
9. Connect each power cord to the power source.
10. Power up the server.

Power supply blank

Remove the component as indicated.

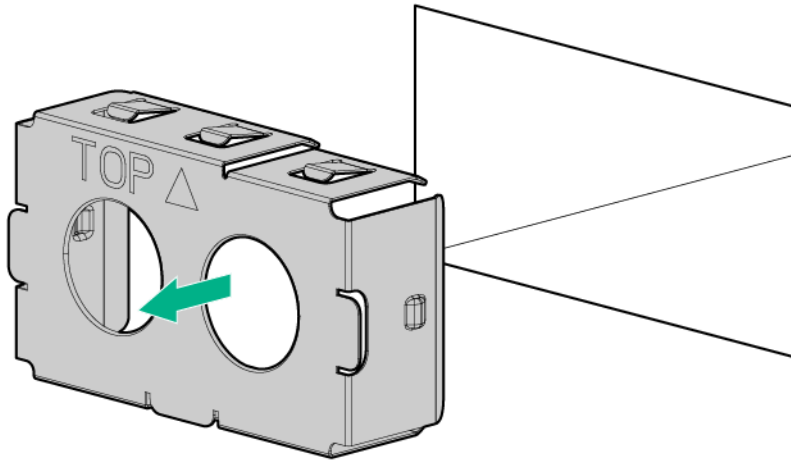

To replace the component, reverse the removal procedure.

AC power supply

CAUTION: To prevent improper cooling and thermal damage, do not operate the server unless all bays are populated with either a component or a blank.

To remove the component:

1. Power down the server (on page 28).
2. Remove all power:
 - a. Disconnect each power cord from the power source.
 - b. Disconnect each power cord from the server.
3. Access the product rear panel (on page 30).
4. Remove the power supply.

WARNING: To reduce the risk of personal injury from hot surfaces, allow the power supply or power supply blank to cool before touching it.

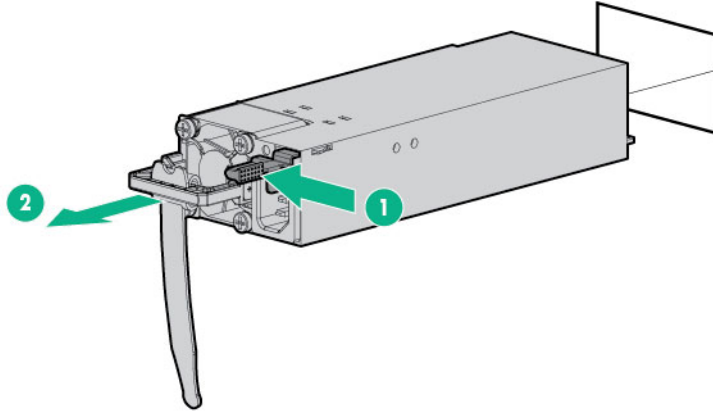

To replace the component, reverse the removal procedure.

System board

⚠ WARNING: To reduce the risk of personal injury, electric shock, or damage to the equipment, remove the power cord to remove power from the server. The front panel Power On/Standby button does not completely shut off system power. Portions of the power supply and some internal circuitry remain active until AC power is removed.

To remove the component:

1. Power down the server (on page 28).
2. Remove all power:
 - a. Disconnect each power cord from the power source.
 - b. Disconnect each power cord from the server.
3. Extend the server from the rack (on page 27).
4. Remove all power supplies ("AC power supply" on page 76).
5. Remove the access panel ("Access panel" on page 31).
6. Depending on the server options installed, do one of the following:
 - o Remove the air baffle ("Air baffle" on page 32).
 - o Remove the mezzanine tray ("Mezzanine tray option" on page 33).
7. Remove the primary PCI riser cage ("Primary 3-slot PCI riser cage" on page 33).
8. If installed, remove the secondary PCIe riser cage ("Remove the secondary PCI riser cage" on page 35).
9. Remove the Smart Storage Battery ("HPE Smart Storage Battery" on page 69).
10. Remove the FlexibleLOM ("FlexibleLOM" on page 54).
11. Remove all DIMMs ("DIMMs" on page 68).
12. Remove the power supplies ("AC power supply" on page 76).
13. Remove the power supply backplane ("Power supply backplane" on page 67).
14. Disconnect all cables connected to the system board.
15. Remove the heatsink ("Heatsink" on page 70).
16. Remove the processor ("Processor" on page 72).

17. Remove the system board.

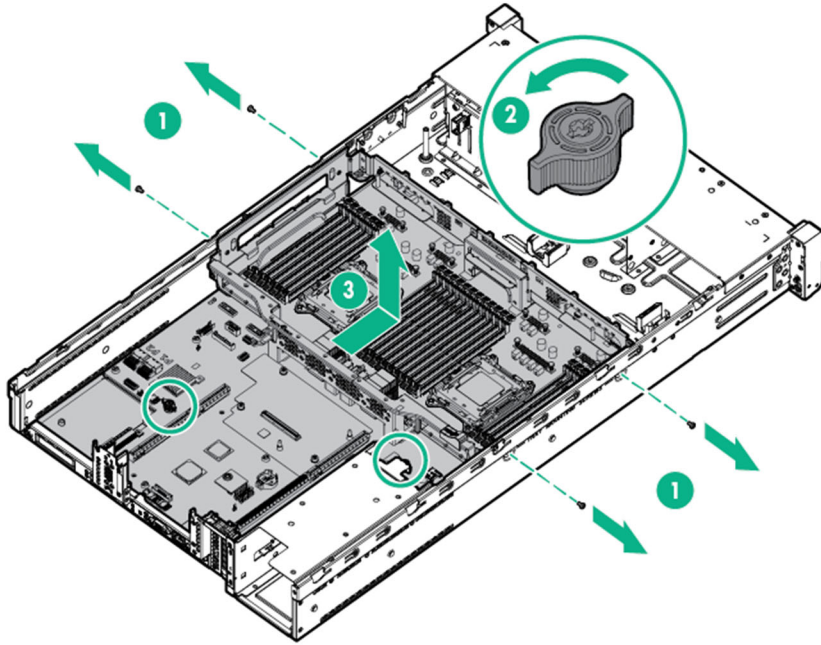

To replace the component:

1. Install the spare system board.

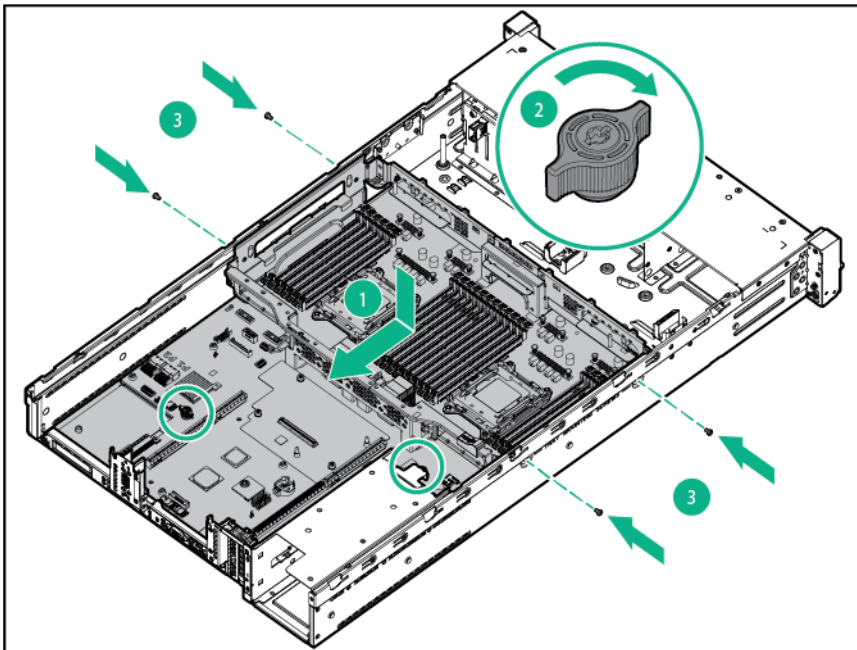

2. Open each of the processor locking levers in the order indicated in the following illustration, and then open the processor retaining bracket.

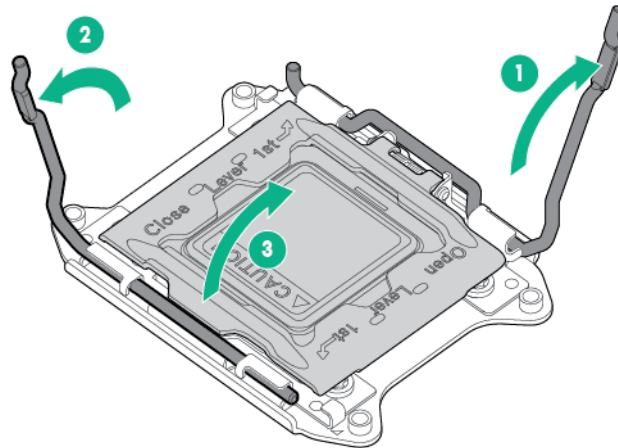

3. Remove the clear processor socket cover. Retain the processor socket cover for future use.

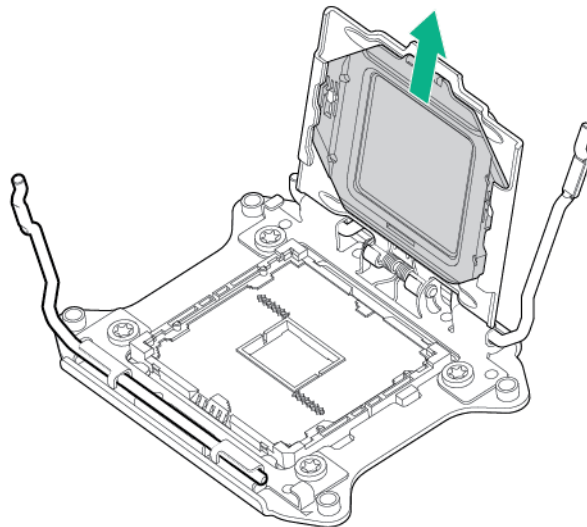

CAUTION: THE PINS ON THE SYSTEM BOARD ARE VERY FRAGILE AND EASILY DAMAGED. To avoid damage to the system board, do not touch the processor or the processor socket contacts.

4. Install the processor. Verify that the processor is fully seated in the processor retaining bracket by visually inspecting the processor installation guides on either side of the processor. **THE PINS ON THE SYSTEM BOARD ARE VERY FRAGILE AND EASILY DAMAGED.**

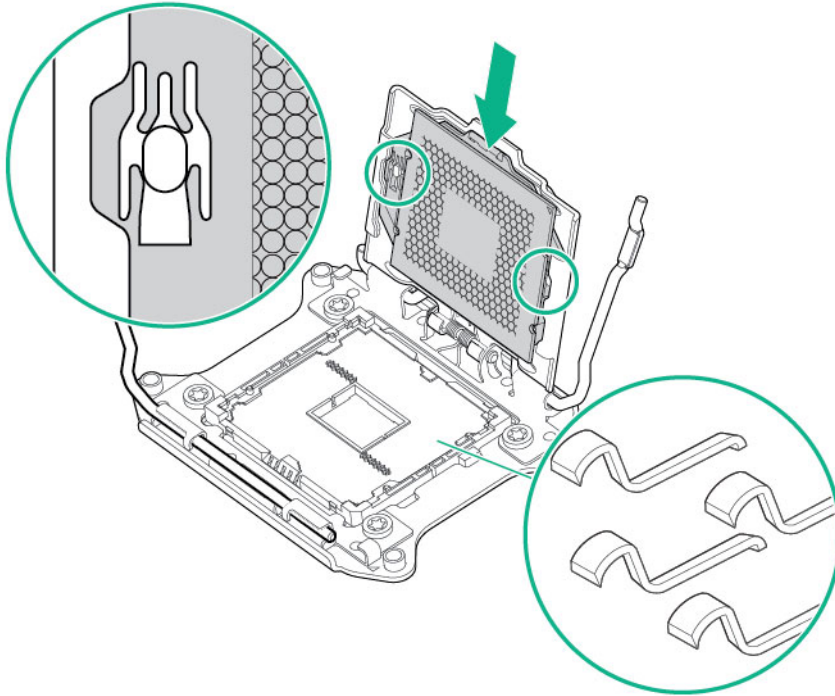

5. Close the processor retaining bracket. When the processor is installed properly inside the processor retaining bracket, the processor retaining bracket clears the flange on the front of the socket.

CAUTION: Do not press down on the processor. Pressing down on the processor may cause damage to the processor socket and the system board. Press only in the area indicated on the processor retaining bracket.

CAUTION: Close and hold down the processor cover socket while closing the processor locking levers. The levers should close without resistance. Forcing the levers closed can damage the processor and socket, requiring system board replacement.

6. Press and hold the processor retaining bracket in place, and then close each processor locking lever. Press only in the area indicated on the processor retaining bracket.

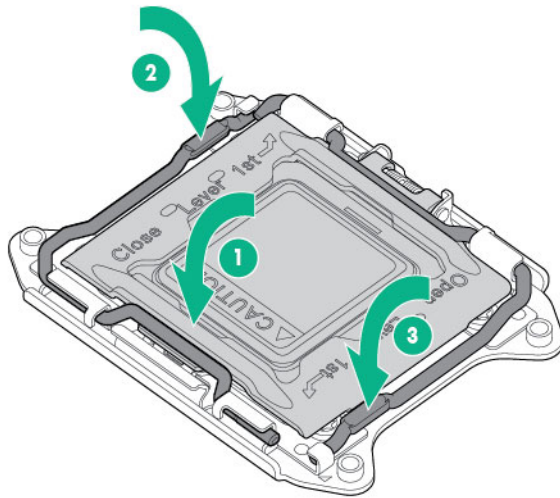

7. Install the processor socket cover onto the processor socket of the failed system board.
8. Clean the old thermal grease from the heatsink and the top of the processor with the alcohol swab. Allow the alcohol to evaporate before continuing.
9. Apply all the grease to the top of the processor in the following pattern to ensure even distribution.

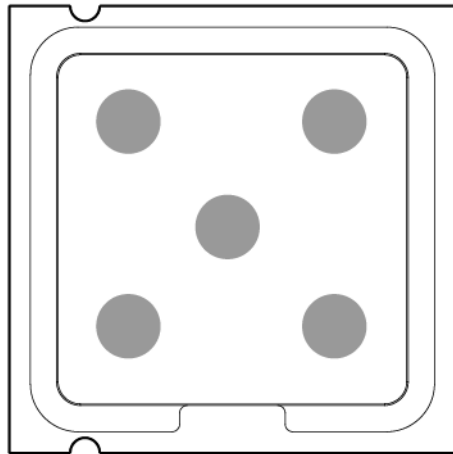

10. Install the heatsink.

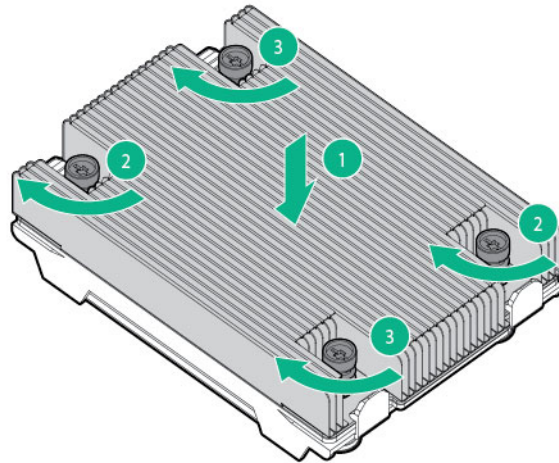

IMPORTANT: Install all components with the same configuration that was used on the failed system board.

11. Install all components removed from the failed system board.
12. Install the access panel ("[Access panel](#)" on page 31).
13. Install the power supplies ("[AC power supply](#)" on page 76).
14. Power up the server.

After you replace the system board, you must re-enter the server serial number and the product ID.

1. During the server startup sequence, press the **F9** key to access RBSU.
2. Select the **Advanced Options** menu.
3. Select **Service Options**.
4. Select **Serial Number**. The following warnings appear:
WARNING! WARNING! WARNING! The serial number is loaded into the system during the manufacturing process and should NOT be modified. This option should only be used by qualified service personnel. This value should always match the serial number sticker located on the chassis.
Warning: The serial number should ONLY be modified by qualified personnel. This value should always match the serial number located on the chassis.
5. Press the **Enter** key to clear the warning.
6. Enter the serial number and press the **Enter** key.
7. Select **Product ID**. The following warning appears:
Warning: The Product ID should ONLY be modified by qualified personnel. This value should always match the Product ID on the chassis.
8. Enter the product ID and press the **Enter** key.
9. Press the **Esc** key to close the menu.
10. Press the **Esc** key to exit RBSU.
11. Press the **F10** key to confirm exiting RBSU. The server automatically reboots.

Setting the server power supply requirements

The server supports one power supply redundancy mode in UEFI System Utilities. To determine if your current server hardware configuration can support a specific redundancy setting, use the HPE Power Advisor on the Hewlett Packard Enterprise website (<http://www.hpe.com/info/poweradvisor/online>).

By default, the server is configured for 1 + 1 power redundancy. In a two-power supply configuration, the server will continue to operate if one power supply fails.

To set the server power supply requirements:

1. Use the HPE Power Advisor (<http://www.hpe.com/info/poweradvisor/online>) to determine the power draw of the system and verify that the server will continue to operate redundantly in the default configuration.
2. To change the redundancy setting in the UEFI System Utilities, proceed with the following steps.
3. To access the UEFI System Utilities, press **F9** during POST.
4. From the System Utilities screen, select **System Configuration > BIOS/Platform Configuration (RBSU) > Advanced Options**.
5. Select the appropriate redundancy configuration from the **Power Supply Requirements** menu, and then press **Enter**.
6. Press **F10** to Save or **F12** to Save and Exit.

System battery

If the server no longer automatically displays the correct date and time, you might need to replace the battery that provides power to the real-time clock.



WARNING: The computer contains an internal lithium manganese dioxide, a vanadium pentoxide, or an alkaline battery pack. A risk of fire and burns exists if the battery pack is not properly handled. To reduce the risk of personal injury:

- Do not attempt to recharge the battery.
 - Do not expose the battery to temperatures higher than 60°C (140°F).
 - Do not disassemble, crush, puncture, short external contacts, or dispose of in fire or water.
 - Replace only with the spare designated for this product.
-

To remove the component:

1. Power down the server (on page 28).
2. Remove all power:
 - a. Disconnect each power cord from the power source.
 - b. Disconnect each power cord from the server.
3. Do one of the following:
 - Extend the server from the rack (on page 27).
 - Remove the server from the rack (on page 28).
4. Remove the access panel ("Access panel" on page 31).
5. Locate the battery ("System board components" on page 99).

6. Remove the battery.

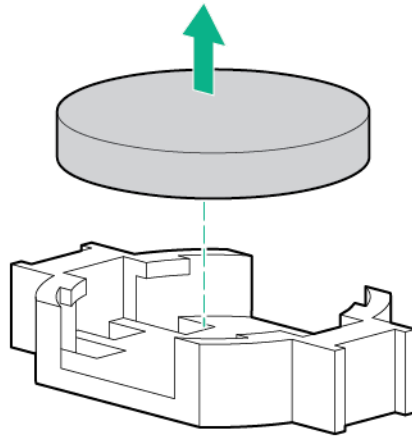

To replace the component, reverse the removal procedure.

For more information about battery replacement or proper disposal, contact an authorized reseller or an authorized service provider.

HP Trusted Platform Module

The TPM is not a customer-removable part.

△ CAUTION: Any attempt to remove an installed TPM from the system board breaks or disfigures the TPM security rivet. Upon locating a broken or disfigured rivet on an installed TPM, administrators should consider the system compromised and take appropriate measures to ensure the integrity of the system data.

If you suspect a TPM board failure, leave the TPM installed and remove the system board ("[System board](#)" on page 77). Contact a Hewlett Packard Enterprise authorized service provider for a replacement system board and TPM board.

Troubleshooting

Troubleshooting resources

The *HPE ProLiant Gen9 Troubleshooting Guide, Volume I: Troubleshooting* provides procedures for resolving common problems and comprehensive courses of action for fault isolation and identification, issue resolution, and software maintenance on ProLiant servers and server blades. To view the guide, select a language:

- English (http://www.hpe.com/support/Gen9_TSG_en)
- French (http://www.hpe.com/support/Gen9_TSG_fr)
- Spanish (http://www.hpe.com/support/Gen9_TSG_es)
- German (http://www.hpe.com/support/Gen9_TSG_de)
- Japanese (http://www.hpe.com/support/Gen9_TSG_ja)
- Simplified Chinese (http://www.hpe.com/support/Gen9_TSG_zh_cn)

The *HPE ProLiant Gen9 Troubleshooting Guide, Volume II: Error Messages* provides a list of error messages and information to assist with interpreting and resolving error messages on ProLiant servers and server blades. To view the guide, select a language:

- English (http://www.hpe.com/support/Gen9_EMG_en)
- French (http://www.hpe.com/support/Gen9_EMG_fr)
- Spanish (http://www.hpe.com/support/Gen9_EMG_es)
- German (http://www.hpe.com/support/Gen9_EMG_de)
- Japanese (http://www.hpe.com/support/Gen9_EMG_ja)
- Simplified Chinese (http://www.hpe.com/support/Gen9_EMG_zh_cn)

Diagnostic tools

Product QuickSpecs

For more information about product features, specifications, options, configurations, and compatibility, see the product QuickSpecs on the Hewlett Packard Enterprise website (<http://www.hpe.com/info/qs>).

HPE iLO

iLO is a remote server management processor embedded on the system boards of HPE ProLiant and Synergy servers. iLO enables the monitoring and controlling of servers from remote locations. HPE iLO management is a powerful tool that provides multiple ways to configure, update, monitor, and repair servers remotely. iLO (Standard) comes preconfigured on HPE servers **without an additional cost or license**.

Features that enhance server administrator productivity are licensed. For more information, see the HPE iLO documentation on the Hewlett Packard Enterprise website (<http://www.hpe.com/info/ilo-docs>).

Active Health System

The HPE Active Health System provides the following features:

- Combined diagnostics tools/scanners
- Always on, continuous monitoring for increased stability and shorter downtimes
- Rich configuration history
- Health and service alerts
- Easy export and upload to Service and Support

The Active Health System monitors and records changes in the server hardware and system configuration. The Active Health System assists in diagnosing problems and delivering rapid resolution if server failures occur.

The Active Health System collects the following types of data:

- Server model
- Serial number
- Processor model and speed
- Storage capacity and speed
- Memory capacity and speed
- Firmware/BIOS

Active Health System does not collect information about Active Health System users' operations, finances, customers, employees, partners, or data center, such as IP addresses, host names, user names, and passwords. Active Health System does not parse or change operating system data from third-party error event log activities, such as content created or passed through by the operating system.

The data that is collected is managed according to the Hewlett Packard Enterprise Data Privacy policy. For more information see the Hewlett Packard Enterprise website (<http://www.hpe.com/info/privacy>).

The Active Health System, in conjunction with the system monitoring provided by Agentless Management or SNMP Pass-thru, provides continuous monitoring of hardware and configuration changes, system status, and service alerts for various server components.

The Agentless Management Service is available in the SPP, which can be downloaded from the Hewlett Packard Enterprise website (<http://www.hpe.com/servers/spp/download>). The Active Health System log can be downloaded manually from iLO 4 or HPE Intelligent Provisioning and sent to Hewlett Packard Enterprise.

For more information, see the following documents:

- *iLO User Guide* on the Hewlett Packard Enterprise website (<http://www.hpe.com/info/ilo/docs>)
- *Intelligent Provisioning User Guide* on the Hewlett Packard Enterprise website (<http://www.hpe.com/info/intelligentprovisioning/docs>)

HPE ProLiant Pre-boot Health Summary

If the server will not start up, you can use iLO to display diagnostic information on an external monitor. This feature is supported on servers that support external video and have a UID button or an SUV connector. When power is available to the server but the server is not powered on, iLO runs on auxiliary power and can take control of the server video adapter to display the HPE ProLiant Pre-boot Health Summary.

For additional information, see the following documents:

- *iLO 4 User Guide* — See the Hewlett Packard Enterprise website (<http://www.hpe.com/info/ilo/docs>).
- *ProLiant Gen9 Troubleshooting Guide, Volume I: Troubleshooting* — See "Troubleshooting Resources (on page 85)."

Integrated Management Log

The IML records hundreds of events and stores them in an easy-to-view form. The IML timestamps each event with 1-minute granularity.

You can view recorded events in the IML in several ways, including the following:

- From within SIM
- From within UEFI System Utilities ("[HPE UEFI System Utilities](#)" on page 87)
- From within the Embedded UEFI shell (on page 89)
- From within operating system-specific IML viewers:
 - For Windows: IML Viewer
 - For Linux: IML Viewer Application
- From within the HPE iLO web interface
- From within Insight Diagnostics ("[HPE Insight Diagnostics](#)" on page 91)

HPE UEFI System Utilities

The UEFI System Utilities is embedded in the system ROM. The UEFI System Utilities enable you to perform a wide range of configuration activities, including:

- Configuring system devices and installed options
- Enabling and disabling system features
- Displaying system information

- Selecting the primary boot controller
- Configuring memory options
- Selecting a language
- Launching other pre-boot environments such as the Embedded UEFI Shell and Intelligent Provisioning

For more information on the UEFI System Utilities, see the *HPE UEFI System Utilities User Guide for HPE ProLiant Gen9 Servers* on the Hewlett Packard Enterprise website (<http://www.hpe.com/info/uefi/docs>).

Scan the QR code located at the bottom of the screen to access mobile-ready online help for the UEFI System Utilities and UEFI Shell. For on-screen help, press **F1**.

Using UEFI System Utilities

To use the UEFI System Utilities, use the following keys.

Action	Key
Access System Utilities	F9 during server POST
Navigate menus	Up and Down arrows
Select items	Enter
Save selections	F10
Access Help for a highlighted configuration option*	F1

*Scan the QR code on the screen to access online help for the UEFI System Utilities and UEFI Shell.

Default configuration settings are applied to the server at one of the following times:

- Upon the first system power-up
- After defaults have been restored

Default configuration settings are sufficient for typical server operations; however, you can modify configuration settings as needed. The system prompts you for access to the UEFI System Utilities each time the system is powered up.

Flexible boot control

This feature enables you to do the following:

- Add Boot Options
 - Browse all FAT16 and FAT32 file systems.
 - Select an X64 UEFI application with an .EFI extension to add as a new UEFI boot option, such as an OS boot loader or other UEFI application.

The new boot option is appended to the boot order list. When you select a file, you are prompted to enter the boot option description (which is then displayed in the Boot menu), as well as any optional data to be passed to an .EFI application.
- Boot to System Utilities

After pre-POST, the boot options screen appears. During this time, you can access the UEFI System Utilities by pressing the **F9** key.
- Choose between supported modes: Legacy BIOS Boot Mode or UEFI Boot Mode



IMPORTANT: If the default boot mode settings are different than the user defined settings, the system may not boot the OS installation if the defaults are restored. To avoid this issue, use the User Defined Defaults feature in UEFI System Utilities to override the factory default settings.

For more information, see the *HPE UEFI System Utilities User Guide for HPE ProLiant Gen9 Servers* on the Hewlett Packard Enterprise website (<http://www.hpe.com/info/uefi/docs>).

Restoring and customizing configuration settings

You can reset all configuration settings to the factory default settings, or you can restore system default configuration settings, which are used instead of the factory default settings.

You can also configure default settings as necessary, and then save the configuration as the custom default configuration. When the system loads the default settings, it uses the custom default settings instead of the factory defaults.

Secure Boot configuration

Secure Boot is integrated in the UEFI specification on which the Hewlett Packard Enterprise implementation of UEFI is based. Secure Boot is completely implemented in the BIOS and does not require special hardware. It ensures that each component launched during the boot process is digitally signed and that the signature is validated against a set of trusted certificates embedded in the UEFI BIOS. Secure Boot validates the software identity of the following components in the boot process:

- UEFI drivers loaded from PCIe cards
- UEFI drivers loaded from mass storage devices
- Pre-boot UEFI shell applications
- OS UEFI boot loaders

Once enabled, only firmware components and operating systems with boot loaders that have an appropriate digital signature can execute during the boot process. Only operating systems that support Secure Boot and have an EFI boot loader signed with one of the authorized keys can boot when Secure Boot is enabled. For more information about supported operating systems, see the *HPE UEFI System Utilities and Shell Release Notes for HPE ProLiant Gen9 Servers* on the Hewlett Packard Enterprise website (<http://www.hpe.com/info/uefi/docs>).

A physically present user can customize the certificates embedded in the UEFI BIOS by adding/removing their own certificates.

When Secure Boot is enabled, the System Maintenance Switch does not restore all manufacturing defaults when set to the ON position. For security reasons, the following are not restored to defaults when the System Maintenance Switch is in the ON position:

- Secure Boot is not disabled and remains enabled.
- The Boot Mode remains in UEFI Boot Mode even if the default boot mode is Legacy Boot Mode.
- The Secure Boot Database is not restored to its default state.
- iSCSI Software Initiator configuration settings are not restored to defaults.

Embedded UEFI shell

The system BIOS in all ProLiant Gen9 servers includes an Embedded UEFI Shell in the ROM. The UEFI Shell environment provides an API, a command line prompt, and a set of CLIs that allow scripting, file manipulation, and system information. These features enhance the capabilities of the UEFI System Utilities.

For more information, see the following documents:

- *HPE UEFI Shell User Guide for HPE ProLiant Gen9 Servers* on the Hewlett Packard Enterprise website (<http://www.hpe.com/info/uefi/docs>)
- *UEFI Shell Specification* on the UEFI website (<http://www.uefi.org/specifications>)

Embedded Diagnostics option

The system BIOS in all ProLiant Gen9 servers includes an Embedded Diagnostics option in the ROM. The Embedded Diagnostics option can run comprehensive diagnostics of the server hardware, including processors, memory, drives, and other server components.

For more information on the Embedded Diagnostics option, see the *HPE UEFI System Utilities User Guide for HPE ProLiant Gen9 Servers* on the Hewlett Packard Enterprise website (<http://www.hpe.com/info/uefi/docs>).

iLO RESTful API support for UEFI

The ProLiant Gen9 servers include support for a UEFI compliant System BIOS, along with UEFI System Utilities and Embedded UEFI Shell pre-boot environments. ProLiant Gen9 servers also support configuring the UEFI BIOS settings using the iLO RESTful API, a management interface that server management tools can use to perform configuration, inventory, and monitoring of a ProLiant server. The iLO RESTful API uses basic HTTPS operations (GET, PUT, POST, DELETE, and PATCH) to submit or return JSON-formatted data with iLO web server.

For more information about the iLO RESTful API and the RESTful Interface Tool, see the Hewlett Packard Enterprise website (<http://www.hpe.com/info/restfulinterface/docs>).

Re-entering the server serial number and product ID

After you replace the system board, you must re-enter the server serial number and the product ID.

1. During the server startup sequence, press the **F9** key to access UEFI System Utilities.
2. Select the **System Configuration > BIOS/Platform Configuration (RBSU) > Advanced Options > Advanced System ROM Options > Serial Number**, and then press the **Enter** key.
3. Enter the serial number and press the **Enter** key. The following message appears:

```
The serial number should only be modified by qualified service personnel.  
This value should always match the serial number located on the chassis.
```
4. Press the **Enter** key to clear the warning.
5. Enter the serial number and press the **Enter** key.
6. Select **Product ID**. The following warning appears:

```
Warning: The Product ID should ONLY be modified by qualified service  
personnel. This value should always match the Product ID located on the  
chassis.
```
7. Enter the product ID and press the **Enter** key.
8. Press the **F10** key to confirm exiting System Utilities. The server automatically reboots.

HPE ProLiant Pre-boot Health Summary

If the server will not start up, you can use iLO to display diagnostic information on an external monitor. This feature is supported on servers that support external video and have a UID button or an SUV connector. When power is available to the server but the server is not powered on, iLO runs on auxiliary power and can take control of the server video adapter to display the HPE ProLiant Pre-boot Health Summary.

For additional information, see the following documents:

- *iLO 4 User Guide* — See the Hewlett Packard Enterprise website (<http://www.hpe.com/info/ilo/docs>).
- *ProLiant Gen9 Troubleshooting Guide, Volume I: Troubleshooting* — See "Troubleshooting Resources (on page 85)."

HPE Insight Diagnostics

The Insight Diagnostics is a proactive server management tool, available in both offline and online versions, that provides diagnostics and troubleshooting capabilities to assist IT administrators who verify server installations, troubleshoot problems, and perform repair validation.

The Insight Diagnostics Offline Edition performs various in-depth system and component testing while the OS is not running. To run this utility, boot the server using Intelligent Provisioning.

The Insight Diagnostics Online Edition is a web-based application that captures system configuration and other related data needed for effective server management. Available in Microsoft Windows and Linux versions, the utility helps to ensure proper system operation.

For more information or to download the utility, see the Hewlett Packard Enterprise website (<http://www.hpe.com/info/InsightDiagnostics>). The Insight Diagnostics Online Edition is also available in the SPP.

HPE Insight Diagnostics survey functionality

HPE Insight Diagnostics (on page 91) provides survey functionality that gathers critical hardware and software information on ProLiant servers.

This functionality supports operating systems that are supported by the server. For operating systems supported by the server, see the Hewlett Packard Enterprise website (<http://www.hpe.com/info/supportos>).

If a significant change occurs between data-gathering intervals, the survey function marks the previous information and overwrites the survey data files to reflect the latest changes in the configuration.

Survey functionality is installed with every Intelligent Provisioning-assisted Insight Diagnostics installation, or it can be installed through the SPP.

USB support

Hewlett Packard Enterprise servers support both USB 2.0 ports and USB 3.0 ports. Both types of ports support installing all types of USB devices (USB 1.0, USB 2.0, and USB 3.0), but may run at lower speeds in specific situations:

- USB 3.0 capable devices operate at USB 2.0 speeds when installed in a USB 2.0 port.
- When the server is configured for UEFI Boot Mode, Hewlett Packard Enterprise provides legacy USB support in the pre-boot environment prior to the operating system loading for USB 1.0, USB 2.0, and USB 3.0 speeds.
- When the server is configured for Legacy BIOS Boot Mode, Hewlett Packard Enterprise provides legacy USB support in the pre-boot environment prior to the operating system loading for USB 1.0 and USB 2.0 speeds. While USB 3.0 ports can be used with all devices in Legacy BIOS Boot Mode, they are not available at USB 3.0 speeds in the pre-boot environment. Standard USB support (USB support from within the operating system) is provided by the OS through the appropriate USB device drivers. Support for USB 3.0 varies by operating system.

For maximum compatibility of USB 3.0 devices with all operating systems, Hewlett Packard Enterprise provides a configuration setting for USB 3.0 Mode. Auto is the default setting. This setting impacts USB 3.0 devices when connected to USB 3.0 ports in the following manner:

- **Auto (default)**—If configured in Auto Mode, USB 3.0 capable devices operate at USB 2.0 speeds in the pre-boot environment and during boot. When a USB 3.0 capable OS USB driver loads, USB 3.0 devices transition to USB 3.0 speeds. This mode provides compatibility with operating systems that do not support USB 3.0 while still allowing USB 3.0 devices to operate at USB 3.0 speeds with state-of-the-art operating systems.
- **Enabled**—If Enabled, USB 3.0 capable devices operate at USB 3.0 speeds at all times (including the pre-boot environment) when in UEFI Boot Mode. This mode should not be used with operating systems that do not support USB 3.0. If operating in Legacy Boot BIOS Mode, the USB 3.0 ports cannot function in the pre-boot environment and are not bootable.
- **Disabled**—If configured for Disabled, USB 3.0 capable devices function at USB 2.0 speeds at all times.

The pre-OS behavior of the USB ports is configurable in the UEFI System Utilities, so that the user can change the default operation of the USB ports. For more information, see the *HPE UEFI System Utilities User Guide for HPE ProLiant Gen9 Servers* on the Hewlett Packard Enterprise website (<http://www.hpe.com/info/uefi/docs>).

External USB functionality

Hewlett Packard Enterprise provides external USB support to enable local connection of USB devices for server administration, configuration, and diagnostic procedures.

For additional security, external USB functionality can be disabled through USB options in UEFI System Utilities.

Internal USB functionality

An internal USB connector is available for use with security key devices and USB drive keys. This solution provides for use of a permanent USB key installed in the internal connector, avoiding issues of clearance on the front of the rack and physical access to secure data.

HPE Smart Storage Administrator

The HPE SSA is a configuration and management tool for HPE Smart Array controllers. Starting with HPE ProLiant Gen8 servers, HPE SSA replaces ACU with an enhanced GUI and additional configuration features.

The HPE SSA exists in three interface formats: the HPE SSA GUI, the HPE SSA CLI, and HPE SSA Scripting. Although all formats provide support for configuration tasks, some of the advanced tasks are available in only one format.

Some HPE SSA features include the following:

- Supports online array capacity expansion, logical drive extension, assignment of online spares, and RAID or stripe size migration
- Provides diagnostic and SmartSSD Wear Gauge functionality on the Diagnostics tab
- For supported controllers, provides access to additional features.

For more information about HPE SSA, see the Hewlett Packard Enterprise website (<http://www.hpe.com/servers/ssa>).

Automatic Server Recovery

ASR is a feature that causes the system to restart when a catastrophic operating system error occurs, such as a blue screen, ABEND (does not apply to HPE ProLiant DL980 Servers), or panic. A system fail-safe timer, the ASR timer, starts when the System Management driver, also known as the Health Driver, is loaded. When the operating system is functioning properly, the system periodically resets the timer. However, when the operating system fails, the timer expires and restarts the server.

ASR increases server availability by restarting the server within a specified time after a system hang. At the same time, the SIM console notifies you by sending a message to a designated pager number that ASR has restarted the system. You can disable ASR from the System Management Homepage or through RBSU.

Component identification

Front panel components

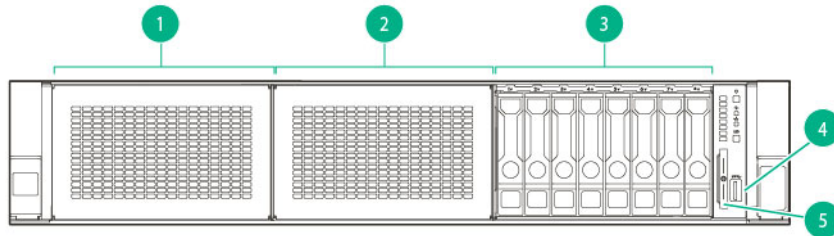

Item	Description
1	Bay 1 — Optional hard drive or universal media bay
2	Bay 2 — Optional hard drive bay
3	Bay 3 — Fixed 8SFF drive bay
4	Front USB 3.0 connector
5	Serial label pull tab

Front panel LEDs

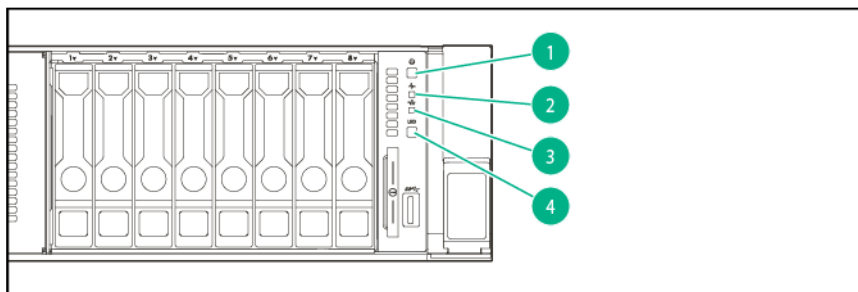

Item	Description	Status
1	Power On/Standby button and system power LED*	Solid green = System on Flashing green (1 Hz/cycle per sec) = Performing power on sequence Solid amber = System in standby Off = No power present**
2	Health LED*	Solid green = Normal Flashing green (1 Hz/cycle per sec) = iLO is rebooting Flashing amber = System degraded Flashing red (1 Hz/cycle per sec) = System critical†
3	NIC status LED*	Solid green = Link to network Flashing green (1 Hz/cycle per sec) = Network active Off = No network activity

Item	Description	Status
4	UID button/LED*	Solid blue = Activated Flashing blue: <ul style="list-style-type: none"> • 1 Hz/cycle per sec = Remote management or firmware upgrade in progress • 4 Hz/cycle per sec = iLO manual reboot sequence initiated • 8 Hz/cycle per sec = iLO manual reboot sequence in progress Off = Deactivated

*When all four LEDs described in this table flash simultaneously, a power fault has occurred. For more information, see "Power fault LEDs (on page 95)."

**Facility power is not present, power cord is not attached, no power supplies are installed, power supply failure has occurred, or the power button cable is disconnected.

†If the health LED indicates a degraded or critical state, review the system IML or use iLO to review the system health status.

Power fault LEDs

The following table provides a list of power fault LEDs, and the subsystems that are affected. Not all power faults are used by all servers.

Subsystem	LED behavior
System board	1 flash
Processor	2 flashes
Memory	3 flashes
Riser board PCIe slots	4 flashes
FlexibleLOM	5 flashes
Removable HPE Flexible Smart Array controller/Smart SAS HBA controller	6 flashes
System board PCIe slots	7 flashes
Power backplane or storage backplane	8 flashes
Power supply	9 flashes

Systems Insight Display option LEDs

The HPE Systems Insight Display LEDs represent the system board layout. The display enables diagnosis with the access panel installed.

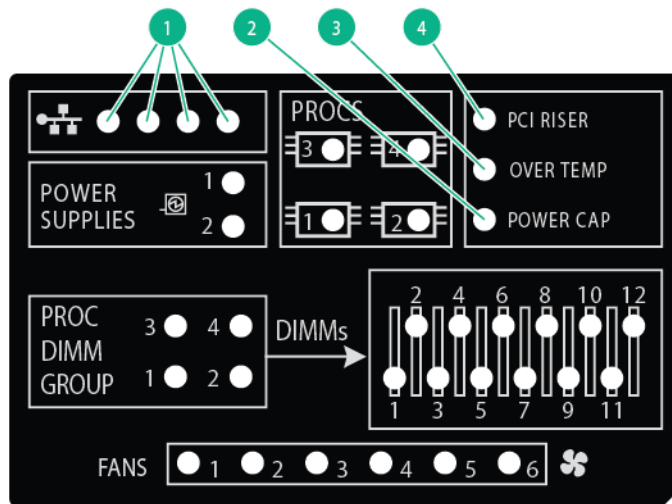

Item	Description	Status
1	NIC link/activity	<ul style="list-style-type: none"> Off = No link to network. If the power is off, view the rear panel RJ-45 LEDs for status. Flashing green = Network link and activity Solid green = Network link
2	Power cap	<ul style="list-style-type: none"> Off = System is in standby, or no cap is set. Solid green = Power cap applied
3	Over temp	<ul style="list-style-type: none"> Off = Normal Solid amber = High system temperature detected
4	PCI riser	<ul style="list-style-type: none"> On = PCIe riser not seated properly Off = Normal
—	All other LEDs	<ul style="list-style-type: none"> Off = Normal Amber = Failure <p>For more information on the activation of these LEDs, see "Systems Insight Display LED combinations (on page 96)."</p>

Systems Insight Display LED combinations

When the health LED on the front panel illuminates either amber or red, the server is experiencing a health event. Combinations of illuminated Systems Insight Display LEDs, the system power LED, and the health LED indicate system status.

Systems Insight Display LED and color	Health LED	System power LED	Status
Processor (amber)	Red	Amber	One or more of the following conditions might exist: <ul style="list-style-type: none"> • Processor in socket <i>X</i> has failed. • Processor <i>X</i> is not installed in the socket. • Processor <i>X</i> is unsupported. • ROM detects a failed processor during POST.
Processor (amber)	Amber	Green	Processor in socket <i>X</i> is in a pre-failure condition.
DIMM (amber)	Red	Green	One or more DIMMs have failed.
DIMM (amber)	Amber	Green	DIMM in slot <i>X</i> is in a pre-failure condition.
Over temp (amber)	Amber	Green	The Health Driver has detected a cautionary temperature level.
Over temp (amber)	Red	Amber	The server has detected a hardware critical temperature level.
Fan (amber)	Amber	Green	One fan has failed or has been removed.
Fan (amber)	Red	Green	Two or more fans have failed or been removed.
Power supply (amber)	Red	Amber	One or more of the following conditions might exist: <ul style="list-style-type: none"> • Only one power supply is installed and that power supply is in standby. • Power supply fault • System board fault
Power supply (amber)	Amber	Green	One or more of the following conditions might exist: <ul style="list-style-type: none"> • Redundant power supply is installed and only one power supply is functional. • AC power cord is not plugged into redundant power supply. • Redundant power supply fault • Power supply mismatch at POST or power supply mismatch through hot-plug addition
Power cap (off)	—	Amber	Standby
Power cap (green)	—	Flashing green	Waiting for power
Power cap (green)	—	Green	Power is available.



IMPORTANT: If more than one DIMM slot LED is illuminated, further troubleshooting is required. Test each bank of DIMMs by removing all other DIMMs. Isolate the failed DIMM by replacing each DIMM in a bank with a known working DIMM.

Rear panel components

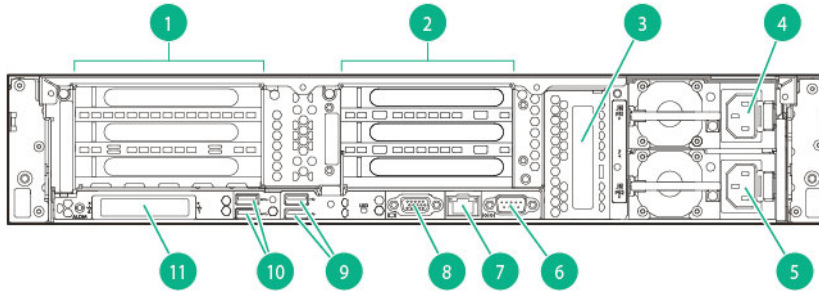

Item	Description
1	PCIe slots 1 to 3 (top to bottom)
2	PCIe slots 4 to 6 (top to bottom)
3	PCIe slot 7
4	Power supply 1 power connector
5	Power supply 2 power connector
6	Serial connector
7	iLO connector
8	VGA connector
9	USB 2.0 connectors (2)
10	USB 3.0 connectors (2)
11	FlexibleLOM ports (Shown: 4x1Gb/Optional: 2x10Gb); port 1 on right side

Non-hot-plug PCIe riser board slot definitions

- Primary riser cage connector, connected to processor 1 or the Southbridge

Slot	PCIe 3-slot riser cage*	PCIe 2-slot x16 riser cage
1 - HL/FH	PCIe3 x16 (8, 4, 2, 1)	—
2 - HL/FH	PCIe3 x16 (8, 4, 2, 1)	PCIe3 x16 (16, 8, 4, 2, 1)
3 - HL/FH	PCIe3 x8 (8, 4, 2, 1)	PCIe3 x8 (8, 4, 2, 1)

- Secondary riser cage connector, connected to processor 2 (Processor 2 must be installed)

Slot	PCIe 3-slot riser cage*	PCIe 2-slot x16 riser cage
4 - HL/FH	PCIe3 x16 (16, 8, 4, 2, 1)	—
5 - HL/FH	PCIe3 x16 (8, 4, 2, 1)	—
6 - HL/FH	PCIe3 x8 (8, 4, 2, 1)	—

- Third slot connector, connected to processor 2 (Processor 2 must be installed)

Slot	PCIe slot
7 - HL/LP	PCIe3 x16 (8, 4, 2, 1)

*Depending on the server model, the server might ship with one or two riser cages installed.

Notes:

"Primary" denotes that the riser cage is installed in the primary riser connector.

"Secondary" denotes that the riser cage is installed in the secondary riser connector.

Installing the riser cages listed in the table above in either the primary or secondary riser connectors determines the form factor of the PCIe cards supported by those riser cages.

FL/FH denotes full-length, full-height. HL/FH denotes half-length, full-height. LP denotes low profile.

The PCIe 2-slot x16 riser cage supports a maximum power of 150 W with a power cable. This cable must be used for PCIe card wattages greater than 75 W.

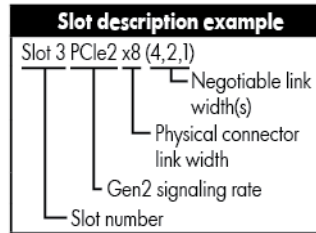

System board components

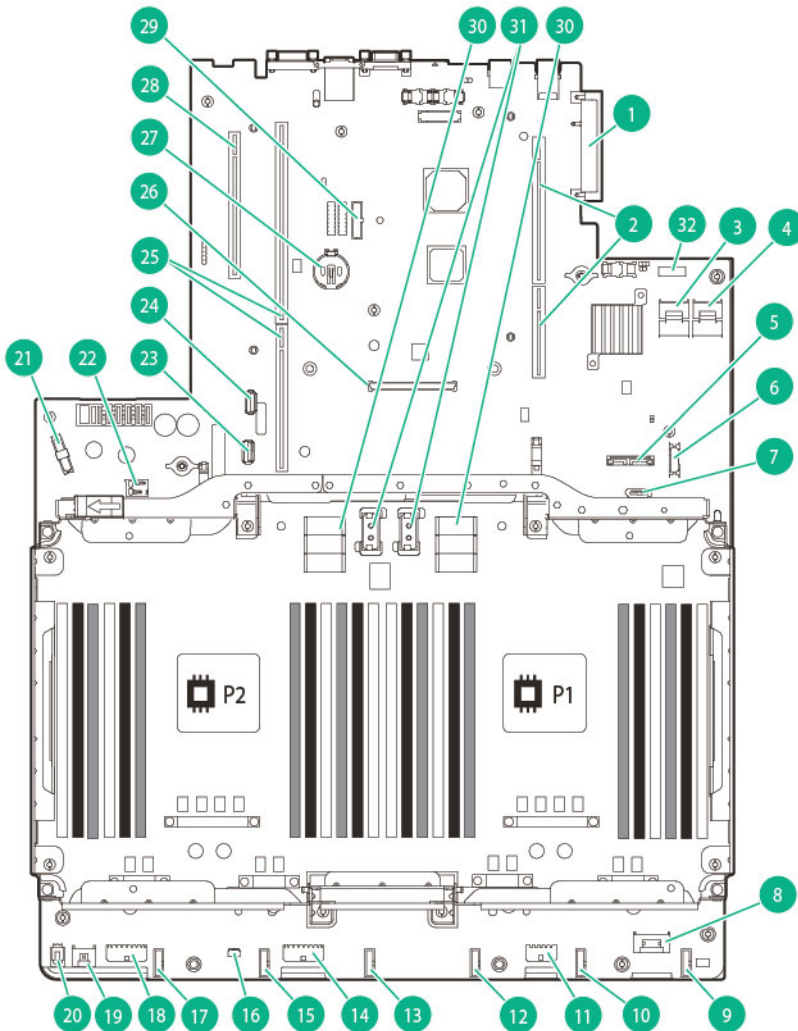

Item	Description
1	FlexibleLOM connector
2	Primary (processor 1) PCIe riser connector
3	x4 SATA port 1
4	x4 SATA port 2
5	Optical/SATA port 4
6	Front power/USB 3.0 connector
7	SATA port 5
8	Front panel connector
9	Fan 6 connector
10	Fan 5 connector
11	Bay 3 drive backplane power connector
12	Fan 4 connector
13	Fan 3 connector
14	Bay 2 drive backplane power connector
15	Fan 2 connector
16	Bay 1 sideband connector
17	Fan 1 connector
18	Bay 1 drive backplane power connector
19	HPE Smart Storage Battery connector
20	Optional Location Discovery Services connector
21	Optional front VGA/USB 2.0 connector
22	microSD card slot
23	Internal USB 3.0 connector
24	Internal USB 2.0 connector
25	Secondary (processor 2) PCIe riser connector
26	AROC connector
27	System battery
28	Additional PCIe slot 7 connector
29	TPM connector
30	Upper mezzanine data connectors
31	Upper mezzanine power connectors
32	System maintenance switch

System maintenance switch

Position	Setting (default = off)
1	Off = iLO security enabled On = iLO security disabled
2	Off = Normal operation On = RBSU does not commit any configuration changes.
5	Off = Normal operation On = Password disabled
6	Off = Normal operation On = Clear CMOS and NVRAM
7	Off = Set default boot mode to UEFI. On = Set default boot mode to Legacy.

Position	Setting (default = off)
3, 4, 8, 9, 10, 11, 12	Reserved

NMI functionality

An NMI crash dump enables administrators to create crash dump files when a system is hung and not responding to traditional debug mechanisms.

Crash dump log analysis is an essential part of diagnosing reliability problems, such as hangs in operating systems, device drivers, and applications. Many crashes freeze a system, and the only available action for administrators is to cycle the system power. Resetting the system erases any information that could support problem analysis, but the NMI feature preserves that information by performing a memory dump before a hard reset.

To force the OS to invoke the NMI handler and generate a crash dump log, the administrator can use the iLO Virtual NMI feature.

For more information, see the Hewlett Packard Enterprise website (<http://www.hpe.com/support/NMI-CrashDump>).

DIMM slot locations

DIMM slots are numbered sequentially (1 through 12) for each processor. The supported AMP modes use the letter assignments for population guidelines.

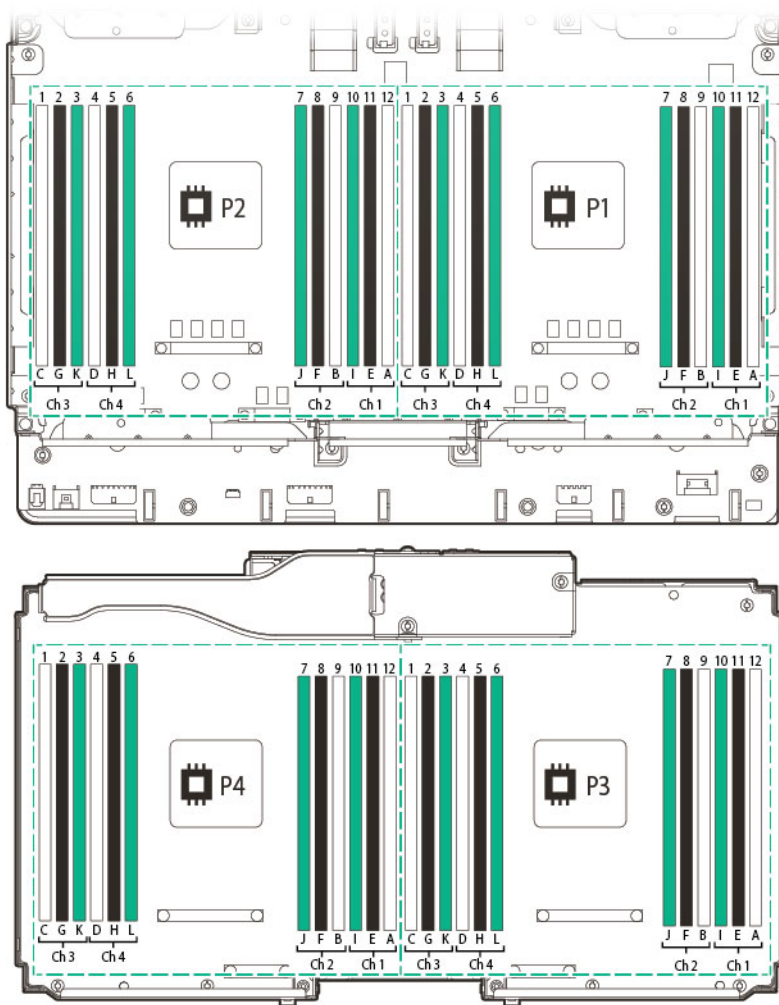

Hot-plug drive bay numbering

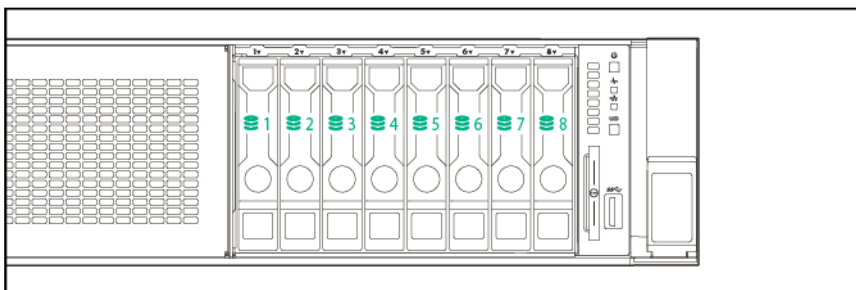

Hot-plug drive LED definitions

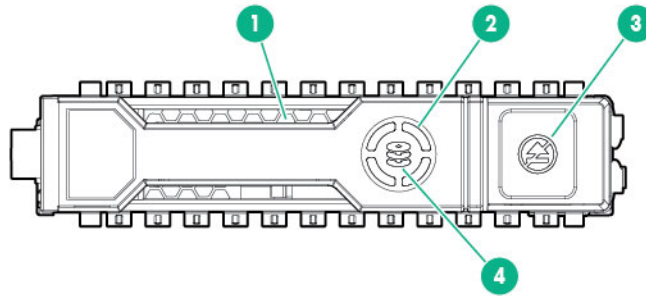

Item	LED	Status	Definition
1	Locate	Solid blue	The drive is being identified by a host application.
		Flashing blue	The drive carrier firmware is being updated or requires an update.
2	Activity ring	Rotating green	Drive activity
		Off	No drive activity
3	Do not remove	Solid white	Do not remove the drive. Removing the drive causes one or more of the logical drives to fail.
		Off	Removing the drive does not cause a logical drive to fail.
4	Drive status	Solid green	The drive is a member of one or more logical drives.
		Flashing green	The drive is rebuilding or performing a RAID migration, strip size migration, capacity expansion, or logical drive extension, or is erasing.
		Flashing amber/green	The drive is a member of one or more logical drives and predicts the drive will fail.
		Flashing amber	The drive is not configured and predicts the drive will fail.
		Solid amber	The drive has failed.
	Off	The drive is not configured by a RAID controller.	

Hot-plug fans



CAUTION: To avoid damage to server components, all fan modules must be installed in fan bays for any processor configuration.

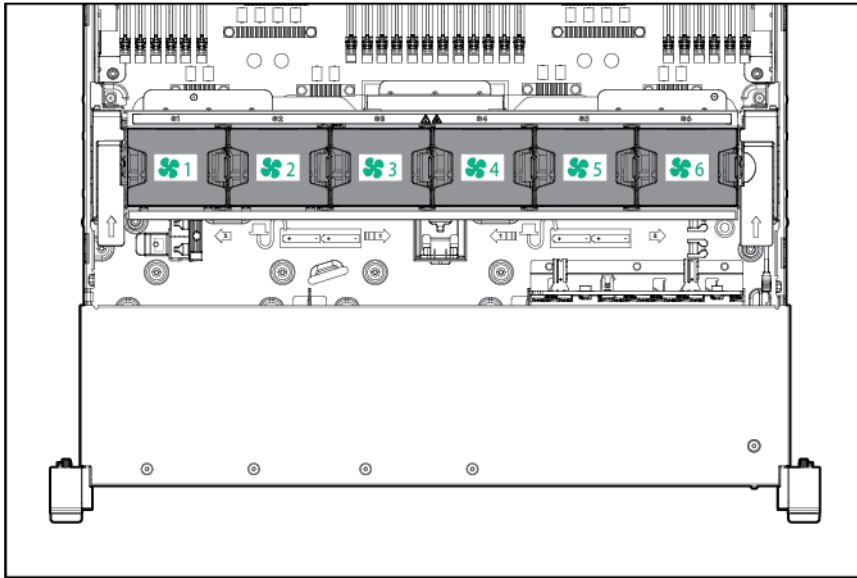

For all processor configurations, the HPE ProLiant DL560 Gen9 Server requires six fan modules for redundancy. A fan failure causes a loss of cooling redundancy. A second fan failure or a missing fan module causes an orderly shutdown of the server.

The server supports variable fan speeds. The fans operate at minimum speed until a temperature change requires a fan speed increase to cool the server.

The server shuts down in the following temperature-related scenarios:

- At POST and in the OS, HPE iLO performs an orderly shutdown if a cautionary temperature level is detected. If the server hardware detects a critical temperature level before an orderly shutdown occurs, the server performs an immediate shutdown.
- When the Thermal Shutdown feature is disabled in RBSU, HPE iLO does not perform an orderly shutdown when a cautionary temperature level is detected. Disabling this feature does not disable the server hardware from performing an immediate shutdown when a critical temperature level is detected.



CAUTION: A thermal event can damage server components when the Thermal Shutdown feature is disabled in RBSU.



IMPORTANT: An immediate shutdown is a hardware-controlled function and it overrides any firmware or software actions.

Storage and expansion diagram

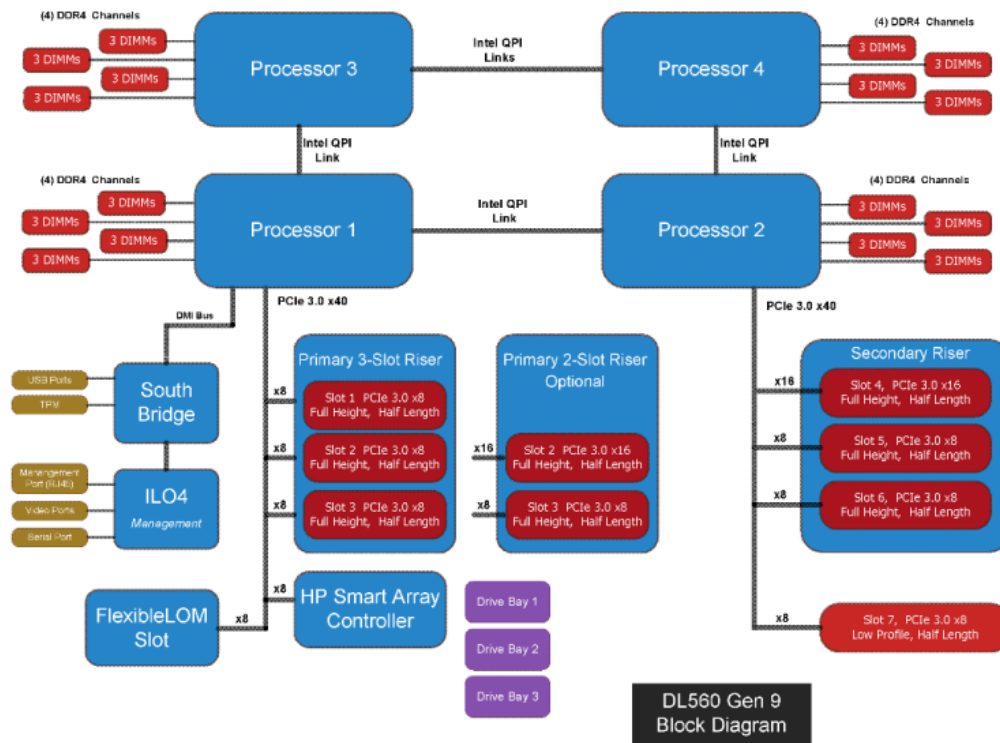

Cabling

Mini-SAS cable option

Cabling configurations and requirements vary depending on the product and installed options:

- For information on cable installation, see the documentation included with the hardware option kit.
- For more information about product features, specifications, options, configurations, and compatibility, see the product QuickSpecs on the Hewlett Packard Enterprise website (<http://www.hpe.com/info/qs>).

SAS drive cabling



IMPORTANT: You might need to remove the far right DIMM to route cables through the cable trough. After the cables have been routed, install the DIMM.

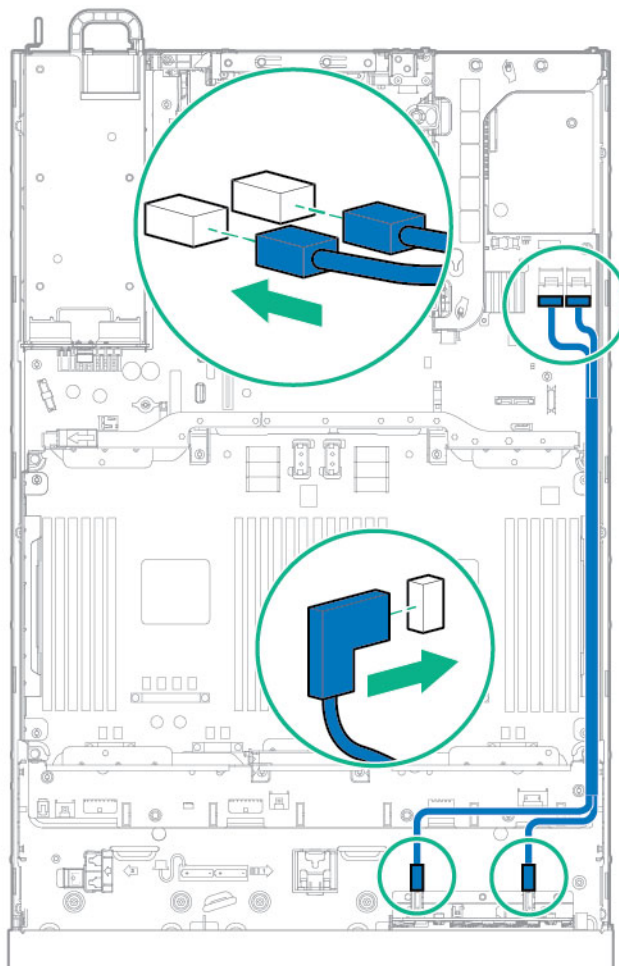

SAS expander card option cabling

Cabling groups:

- Group A — Controller to SAS expander card

Cable	Description	Connection to SAS expander	Connection to controller
793961-001	2x4 SAS cable, H240 HBA connector	Port 1, Port 2	R2
793962-001	2x4 SAS cable, H240 HBA connector	Port 1, Port 2	Slot 7
793963-001	1x8 SAS cable, P440/P840 controller connector	Port 1, Port 2	R1
793964-001	1x8 SAS cable, P440 controller connector	Port 1, Port 2	R2, Slot 7

- Group B — SAS expander card to AROC controller

Cable	Description	Connection to SAS expander	Connection to controller
793956-001	2x4 SAS cable	Port 1, Port 2	R1

- Group C — SAS expander card to front SFF drive cage

Cable	Description	Connection to SAS expander	Connection to drive bay
793957-001	2x4 Mini-SAS cable	Port 3, Port 4	Bay 1
793958-001	2x4 Mini-SAS cable	Port 5, Port 6	Bay 2
793959-001	2x4 Mini-SAS cable	Port 7, Port 8	Bay 3
793960-001	1x4 SAS cable, SFF cable	Port 3	R1, Port 3

Specifications

Environmental specifications

Specification	Value
Temperature range*	
Operating	10°C to 35°C (50°F to 95°F)
Shipping	-30°C to 50°C (-22°F to 122°F)
Storage	-30°C to 60°C (-22°F to 140°F)
Maximum wet bulb temperature	28°C (82.4°F)
Relative humidity (noncondensing)**	
Operating	10% to 90%
Non-operating	5% to 95%

* All temperature ratings shown are for sea level. An altitude derating of 1°C per 300 m (1.8°F per 1,000 ft) to 3048 m (10,000 ft) is applicable. No direct sunlight allowed. Maximum rate of change is 20°C/hr (36°F/hr). The upper limit and rate of change might be limited by the type and number of options installed. System performance during standard operating support might be reduced if operating with a fan fault or above 30°C (86°F).

For certain approved hardware configurations, the supported system inlet temperature range is extended:

-Temperatures 5°C to 10°C (41°F to 50°F) and 35°C to 40°C (95°F to 104°F) at sea level with an altitude derating of 1.0°C per every 175 m (1.8°F per every 574 ft) above 900 m (2953 ft) to a maximum of 3048 m (10,000 ft).

-Temperatures 40°C to 45°C (104°F to 113°F) at sea level with an altitude derating of 1.0°C per every 125 m (1.8°F per every 410 ft) above 900 m (2953 ft) to a maximum of 3048 m (10,000 ft).

The approved hardware configurations for this system are listed on the Hewlett Packard Enterprise website (<http://www.hpe.com/servers/ASHRAE>).

** Storage maximum humidity of 95% is based on a maximum temperature of 45°C (113°F). Altitude maximum for storage corresponds to a pressure minimum of 70 KPa.

Mechanical specifications

Specification	Value
Height	8.73 cm (3.44 in)
Depth	74.93 cm (29.50 in)
Width	44.54 cm (17.54 in)
Weight (maximum)	27.66 kg (61.00 lb)
Weight (minimum)	18.59 kg (41.00 lb)

Power supply specifications

Depending on installed options, the server is configured with one of the following power supplies:

- HPE 1500 W Common Slot Platinum Plus Hot-plug Power Supply ("HPE 1500 W Common Slot Platinum Plus Hot-Plug Power Supply (94% efficiency)" on page 109)
- HPE 1200 W Common Slot Platinum Plus Hot-plug Power Supply (94% efficiency) (on page 109)
- HPE 1500 W Common Slot -48 VDC Hot-plug Power Supply (on page 110)

For detailed power supply specifications, see the QuickSpecs on the Hewlett Packard Enterprise website (<http://www.hpe.com/info/proliant/powersupply>).

HPE 1500 W Common Slot Platinum Plus Hot-Plug Power Supply (94% efficiency)

Specification	Value
Input requirements	
Rated input voltage	200 to 240 VAC
Rated input frequency	50 Hz to 60 Hz
Rated input current	8.3 A at 200 VAC
Maximum rated input power	1652 W at 230 VAC input
BTUs per hour	5637 at 230 VAC input
Power supply output	
Power supply output	1500 W
Rated steady-state power	1500 W at 200 V to 240 VAC input
Maximum peak power	1500 W at 200 V to 240 VAC input

HPE 1200 W Common Slot Platinum Plus Hot-Plug Power Supply (94% efficiency)

Specification	Value
Input requirements	
Rated input voltage	100 VAC, 100 to 120 VAC
Rated input frequency	50 Hz to 60 Hz
Rated input current	<ul style="list-style-type: none"> • 9.2 A at 100 VAC • 9.5 A at 110 to 120 VAC • 6.6 A at 200 to 240 VAC
Maximum rated input power	<ul style="list-style-type: none"> • 1000 W at 120 VAC input • 1320 W at 230 VAC input
BTUs per hour	<ul style="list-style-type: none"> • 3408 at 120 VAC input • 4500 at 230 VAC input
Power supply output	
Power supply output	<ul style="list-style-type: none"> • 800 W at 100 VAC input (low line) • 900 W at 108 V to 132 VAC input (low line) • 1200 W at 200 V to 240 VAC input (high line)
Rated steady-state power	<ul style="list-style-type: none"> • 800 W at 100 VAC input • 900 W at 120 VAC input • 1200 W at 200 V to 240 VAC input

Maximum peak power	<ul style="list-style-type: none"> • 800 W at 100 VAC input • 900 W at 120 VAC input • 1200 W at 200 V to 240 VAC input
--------------------	--

HPE 1500 W Common Slot -48 VDC Hot-plug Power Supply

Specification	Value
Input requirements	
Rated input voltage	-40 VDC to -72 VDC
Rated input current	<ul style="list-style-type: none"> • 42.0 A at -40 VDC input • 33.5 A at -48 VDC input • 22.2 A at -72 VDC input
Rated input power (W)	<ul style="list-style-type: none"> • 1621 W at -40 VDC input • 1607 W at -48 VDC input, nominal input • 1598 W at -72 VDC input
Rated input power (BTUs per hour)	<ul style="list-style-type: none"> • 5530 at -40 VDC input • 5484 at -48 VDC input • 5451 at -72 VDC input
Power supply output	
Rated steady-state power (W)	1500 W at -40 VDC to -72 VDC
Maximum peak power (W)	1500 W at -40 VDC to -72 VDC



CAUTION: This equipment is designed to permit the connection of the earthed conductor of the DC supply circuit to the earthing conductor at the equipment. If this connection is made, all of the following must be met:

- This equipment must be connected directly to the DC supply system earthing electrode conductor or to a bonding jumper from an earthing terminal bar or bus to which the DC supply system earthing electrode conductor is connected.
- This equipment must be located in the same immediate area (such as adjacent cabinets) as any other equipment that has a connection between the earthed conductor of the same DC supply circuit and the earthing conductor, and also the point of earthing of the DC system. The DC system must be earthed elsewhere.
- The DC supply source is to be located within the same premises as the equipment.
- Switching or disconnecting devices must not be in the earthed circuit conductor between the DC source and the point of connection of the earthing electrode conductor.



CAUTION: To reduce the risk of electric shock or energy hazards:

- This equipment must be installed by trained service personnel, as defined by the NEC and IEC 60950-1, Second Edition, the standard for Safety of Information Technology Equipment.
- Connect the equipment to a reliably grounded SELV source. An SELV source is a secondary circuit that is designed so normal and single fault conditions do not cause the voltages to exceed a safe level (60 V DC).
- The branch circuit overcurrent protection must be rated 24 A.

Hot-plug power supply calculations

For hot-plug power supply specifications and calculators to determine electrical and heat loading for the server, see the Hewlett Packard Enterprise Power Advisor website (<http://www.hpe.com/info/poweradvisor/online>).

Acronyms and abbreviations

DDR

double data rate

EV

enterprise value (HPE SSD endurance class)

FBWC

flash-backed write cache

iLO

Integrated Lights-Out

IML

Integrated Management Log

MDL

midline (HPE Midline drive family)

MLC

multilevel cell (NAND memory type used in SSDs)

NMI

nonmaskable interrupt

NVRAM

nonvolatile memory

PCIe

Peripheral Component Interconnect Express

POST

Power-On Self Test

RBSU

ROM-Based Setup Utility

RI

Read Intensive

SAS

serial attached SCSI

SATA

serial ATA

SC

Smart Carrier

SFF

small form factor

TPM

Trusted Platform Module

UID

unit identification

USB

universal serial bus

WI

Write Intensive

Documentation feedback

Hewlett Packard Enterprise is committed to providing documentation that meets your needs. To help us improve the documentation, send any errors, suggestions, or comments to Documentation Feedback (<mailto:docsfeedback@hpe.com>). When submitting your feedback, include the document title, part number, edition, and publication date located on the front cover of the document. For online help content, include the product name, product version, help edition, and publication date located on the legal notices page.

Index

A

- AC power supply 76
- access panel 31
- air baffle 32
- ASR (Automatic Server Recovery) 93
- Automatic Server Recovery (ASR) 93

B

- backplane, hard drive 42, 43
- backplane, power supply 67
- blue screen event 101
- boot configurations 89
- boot options 87, 88, 90
- buttons 94

C

- cable management arm 30
- cables 106
- cabling 106, 107
- cautions 25, 26
- Change Control 87, 88
- components 15, 18, 25, 94
- components, identification 15, 18, 94
- configuration settings 89
- connectors 94
- controller 66
- controller options 66
- crash dump analysis 101
- CSR (customer self repair) 5
- customer self repair (CSR) 5

D

- diagnostic tools 86, 88, 90, 91, 93
- diagnostics utility 91
- DIMM identification 102
- DIMM slot locations 102
- DIMM slots 68
- DIMMs 68
- documentation feedback 114
- drive 40
- drive bays 41
- drive blank 40
- drive cage assembly 41
- drive LEDs 103
- drives 103

E

- electrostatic discharge 25
- embedded UEFI shell 89
- error messages 85
- expansion 105
- expansion boards 60
- expansion slot blanks 59
- extend server from rack 27
- external USB functionality 92

F

- fan cage 39
- fans 38, 39, 103
- features 94
- FlexibleLOM 54
- front bezel 55
- front panel buttons 94
- front panel components 94
- front panel LEDs 94

G

- grounding methods 25
- grounding requirements 25

H

- hard drive LEDs 103
- hard drives, determining status of 103
- health driver 93
- heatsink 70
- Hewlett Packard Enterprise Technical Support 5
- hot-plug drive 40, 102
- hot-plug fans 103
- hot-plug power supply calculations 111
- HP Trusted Platform Module option 83
- HPE iLO 86
- HPE Insight Diagnostics 91
- HPE Insight Diagnostics survey functionality 91
- HPE ProLiant Pre-boot Health Summary 87
- HPE Smart Storage Administrator (HPE SSA) 92
- HPE Smart Storage Battery 69, 83
- HPE SSA (HPE Smart Storage Administrator) 92
- HPE Systems Insight Manager (SIM) 91

I

- illustrated parts catalog 15
- iLO (Integrated Lights-Out) 86
- IML (Integrated Management Log) 87

Insight Diagnostics 91
Integrated Management Log (IML) 87
Intelligent Provisioning 87, 88, 91
internal USB connector 91
internal USB functionality 92

L

LEDs 94, 96, 103
LEDs, front panel 94, 103
LEDs, hard drive 103
LEDs, power supply 95
LEDs, SAS hard drive 203
LEDs, troubleshooting 85
location discovery services 56

M

maintenance 25
management tools 86
mechanical components 15
mechanical specifications 108
memory dump 101
mezzanine tray 33
Mini-SAS cable 106, 107
Mini-SAS cabling 107

N

NMI functionality 101
NMI switch 101

O

operating system crash 93, 101
optical drive 53

P

part numbers 15
PCI expansion slots 98
PCI riser cage 33
PCIe riser board 34
POST error messages 85
power calculator 111
power specifications 108
power supplies 76, 108
power supply 76, 108, 111
power supply backplane 67
power supply blank 76
power supply calculations 111
power supply LEDs 95
power supply specifications 109, 110
power supply, hot-plug 108, 111
powering down 28
preparation procedures 26
problem diagnosis 85, 86
processor option 72
processors 72

ProLiant Pre-boot Health Summary 87

Q

QuickSpecs 86

R

rack, extending server from 25, 27
RAID configuration 92
rear components 98
rear panel components 98
rear panel connectors 98
rear panel, accessing 30
removal and replacement procedures 25
remove server from rack 28
RESTful API 90

S

safety considerations 25
SAS expander 61, 107
SAS hard drive cabling 106
secondary PCI riser cage blank 35
secure boot configuration 89
serial number 90
server warnings and cautions 26
Service Pack for ProLiant 91
software 87
specifications 108, 111
specifications, environmental 108
specifications, mechanical 108
specifications, server 108
static electricity 25
storage configuration 105
switch, NMI 101
switches 101
symbols on equipment 25
system board replacement 77, 83
system components 18, 94, 99
system maintenance switch 100, 101
Systems Insight Display 30, 36, 96
Systems Insight Display LEDs 96

T

T-10/T-15 Torx screwdriver 25
technical support 5
tools 25
TPM (Trusted Platform Module) 83
troubleshooting 85

U

UEFI, server profile 89
UID LED 101
universal media bay 44, 46
USB support 91
utilities 86, 87, 88

W

warnings 26

warranty 5

warranty information 5