

phil&teds®
adapt&survive!™

dot™
instructions

IMPORTANT:

**This document contains instructions
and must be kept for future reference.**

Please read thoroughly before use.

please register your product
purchase online now

philandteds.com/register







cleaning & caring

check dot™ for cuts & bruises. if your product is damaged in any way, or you're not sure how to use it, please consult our web support (www.philandteds.com/support). here you can get in touch with a local customer care team, made of real live people.

caring for dot™

unlike your children, your dot™ likes to stay clean.

- code brown got you down? never fear! dot™ fabric can be sponge cleaned with warm water, using mild natural soap. do not use detergents or bleach on dot™.
- improper care will void any warranties. do not use dot™ if deterioration is detected or suspected.

important information

aerotech tyres

- tyres are not under warranty, however dot™ uses aerotech tyres which are immune from punctures & eliminate the need for tube replacements.



for more information on caring for your
dot™, philandteds.com/support

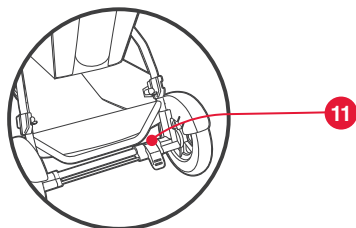
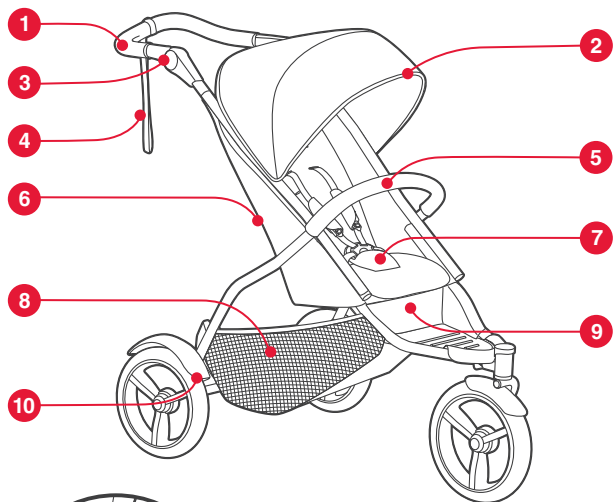



- 1 handlebar
- 2 sunhood
- 3 handlebar adjustor
- 4 wrist strap
- 5 grab bar
- 6 recline strap
- 7 harness
- 8 parcel tray
(max load 5kg / 11lbs)
- 9 fast fold
- 10 mud guards
- 11 brake



- | | | | |
|----|---|----|--|
| 1 | Guidon | 1 | Griff |
| 2 | Capote | 2 | Sonnenverdeck |
| 3 | Bouton de réglage
de la poignée | 3 | Hanbremse |
| 4 | Sangle poignet | 4 | jogging-Band |
| 5 | Arceau de maintien | 5 | Buggybügel |
| 6 | Sangle pour l'inclinaison | 6 | Liege- Verstellriemen |
| 7 | Harnais | 7 | Gurt |
| 8 | Panier de rangement
(max load 5kg / 11lbs) | 8 | Gepäckkorb (maximale
Belastung 5kg / 11lbs) |
| 9 | Pliage facile d'une main | 9 | Sicheres Lenken mit nur
einer Hand |
| 10 | Garde-boue arrière | 10 | Schutzbleche hinten |
| 11 | Frein | 11 | Bremse |



- | | | | |
|----|---------------------------------|----|---|
| 1 | Manillar | 1 | Duw beugel |
| 2 | Tapa sol | 2 | Zonnekap |
| 3 | Freno de mano | 3 | Duw beugel versteller |
| 4 | Correa para la muñeca | 4 | Polsband |
| 5 | Barra delantera | 5 | Bumper |
| 6 | Correa de inclinación | 6 | Zit-positie verstelriem |
| 7 | Arnés | 7 | Veiligheidsharnas |
| 8 | cesta (carga máx. 5kg) | 8 | Boodschappentakje
(max load 5kg / 11lbs) |
| 9 | Mecanismo de plegar
fastfold | 9 | Met één hand in te klappen |
| 10 | Protectores traseros | 10 | Spatborden achter |
| 11 | Freno | 11 | Rem |



max load
20kg / 44lbs



max load
9kg / 20lbs



C1 max load
20kg / 44lbs

C2 max load
9kg / 20lbs

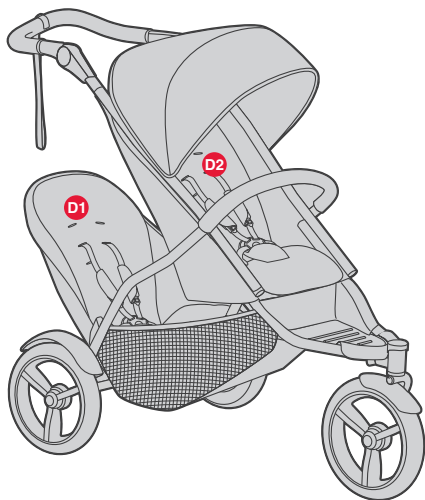

D1 max load
15kg / 33lbs

D2 max load
20kg / 44lbs



E1

max load

12kg / 26lbs*

*parent facing mode

is for single use only



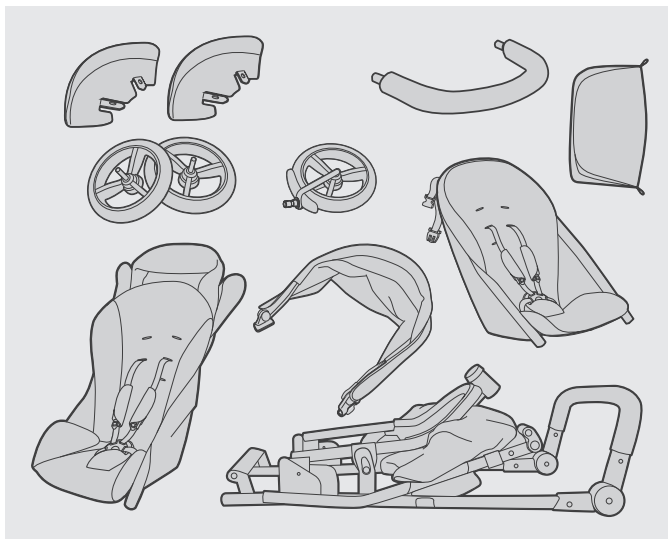

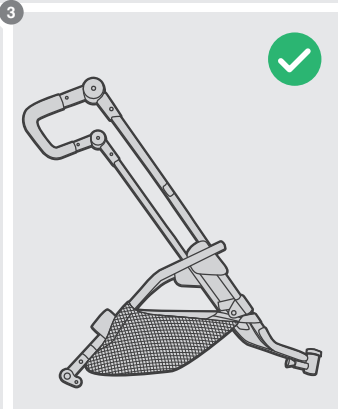
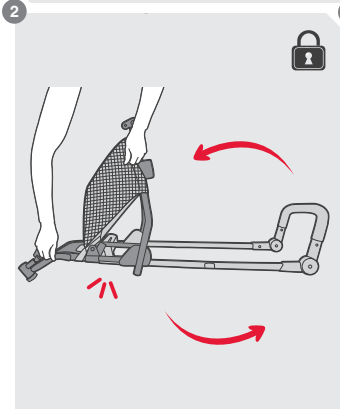
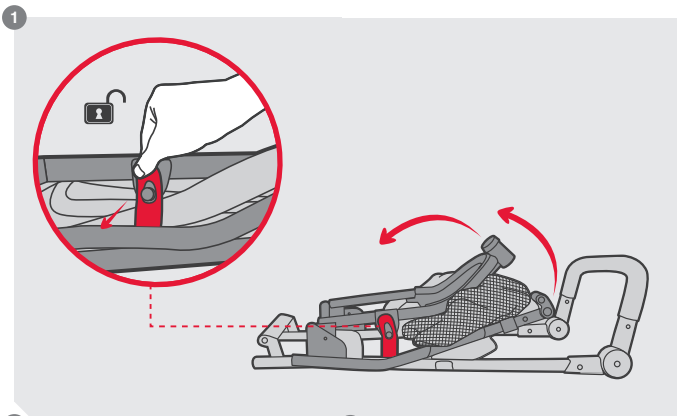



1

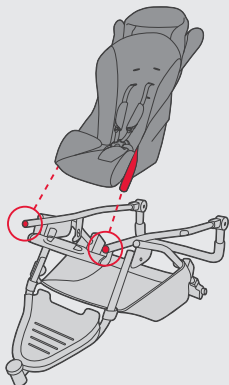

2

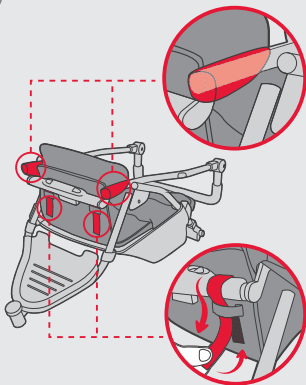

3

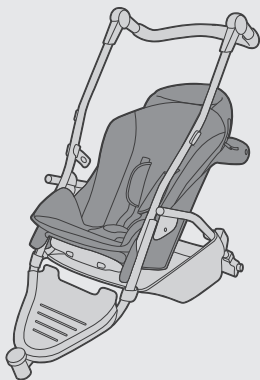

4

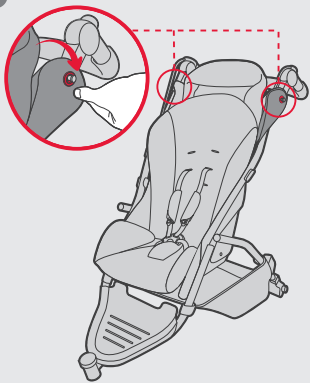

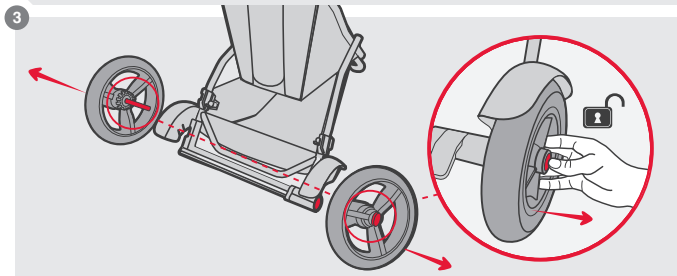
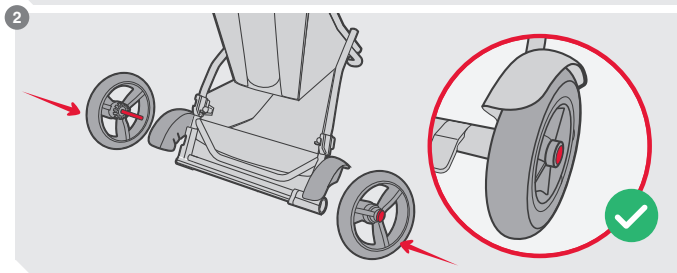
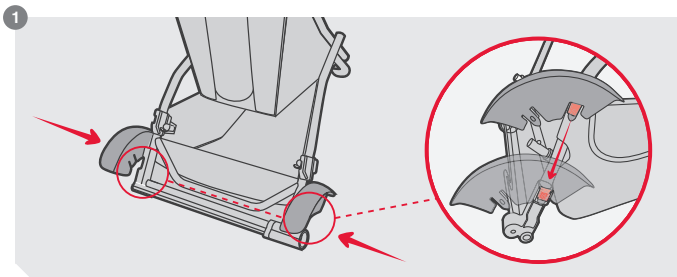



max load
20kg / 44lbs

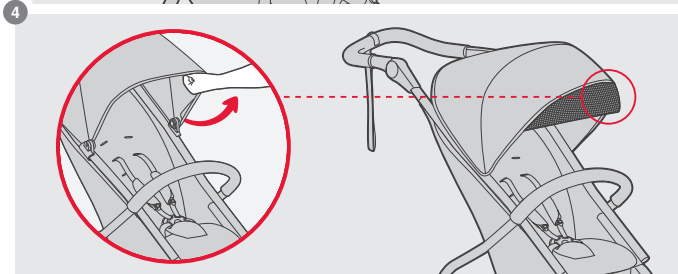
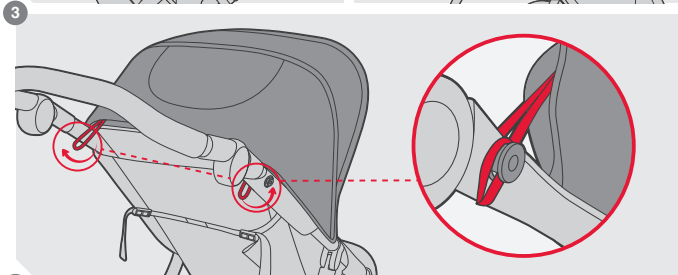
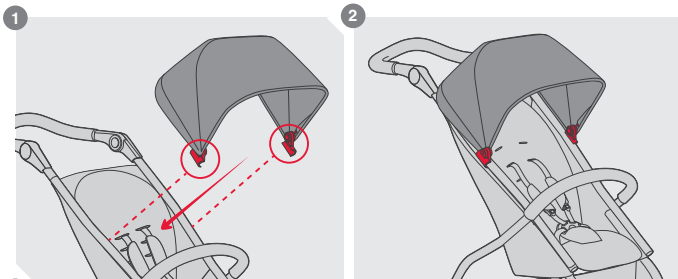

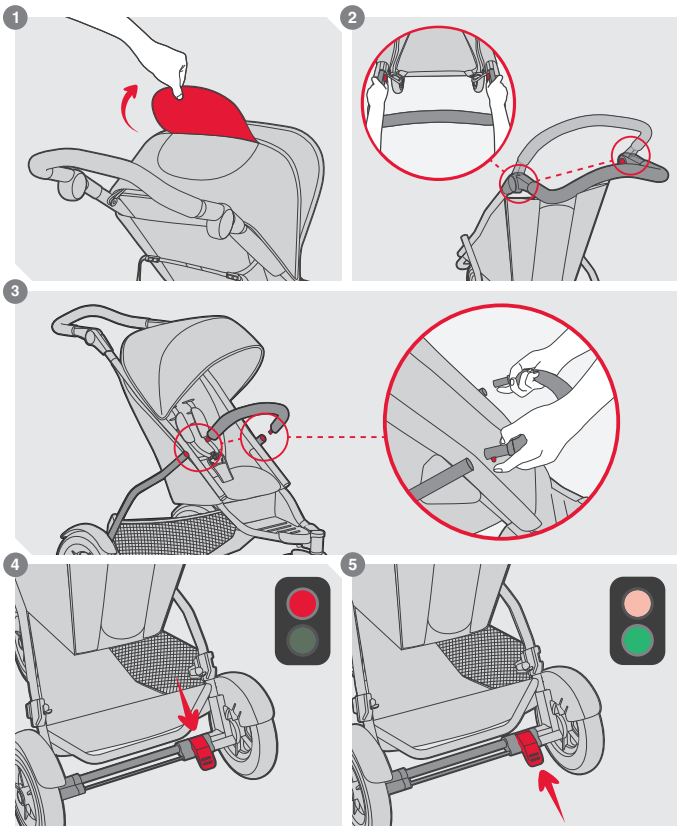

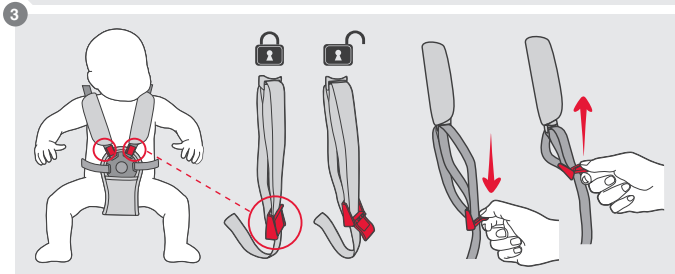
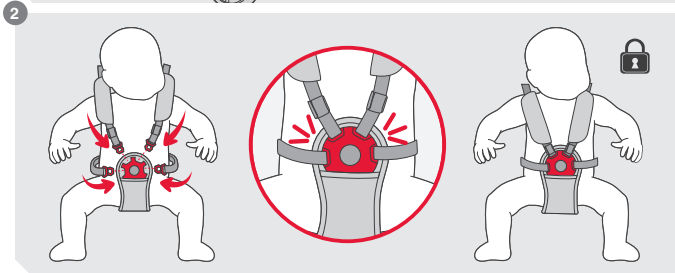
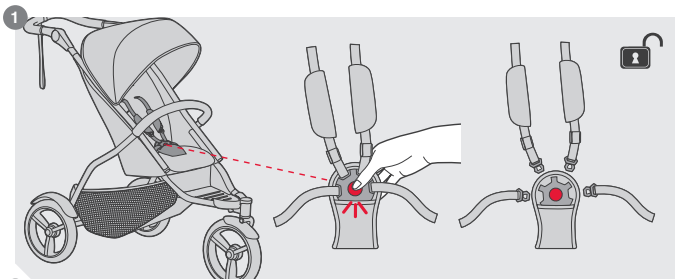

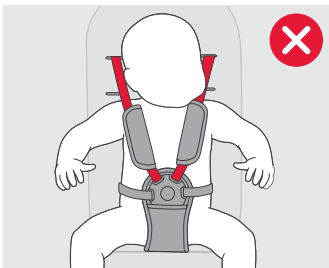
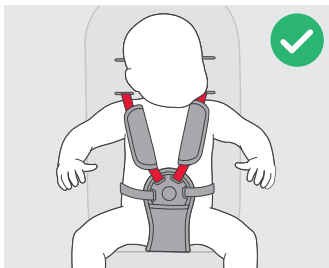
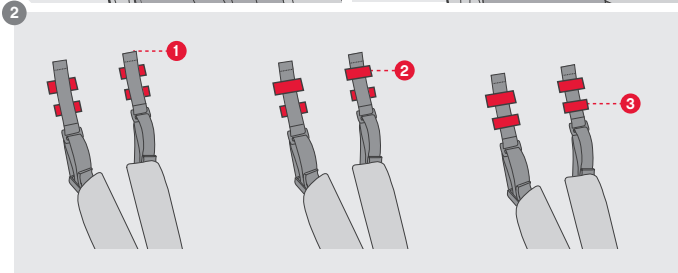
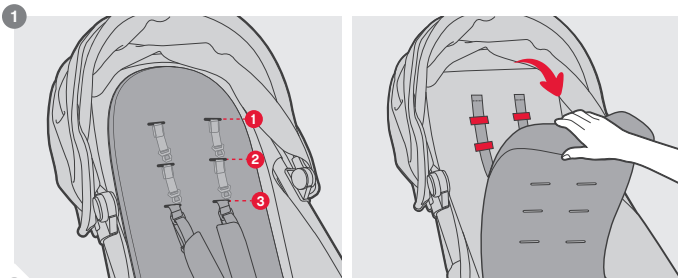

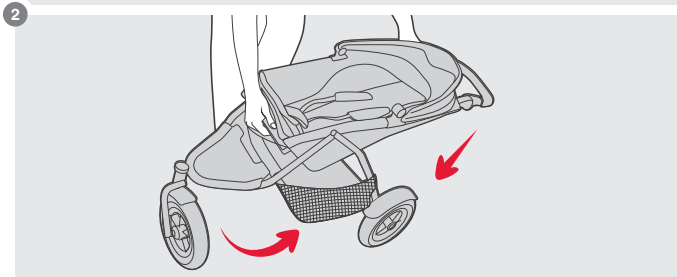
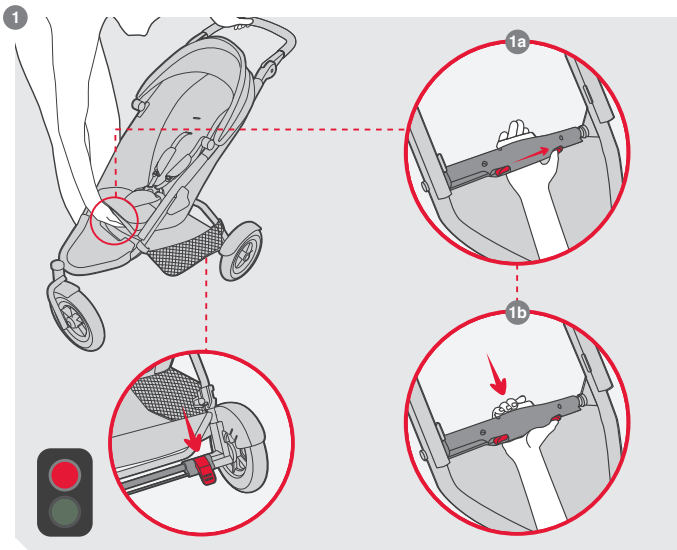

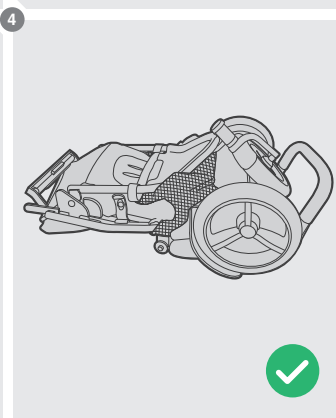
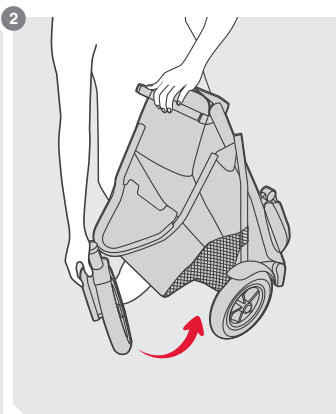
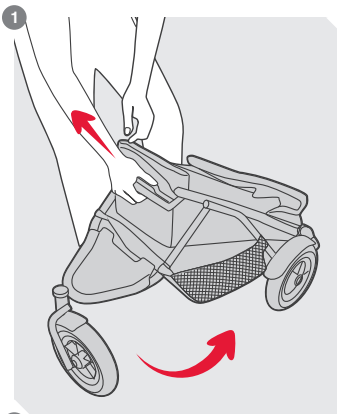





max load
9kg / 20lbs



a

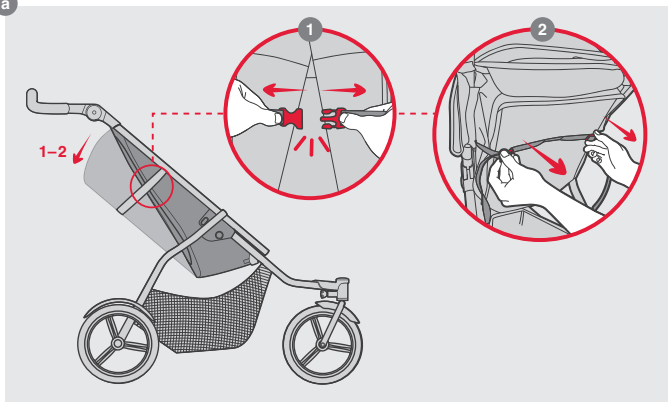



b

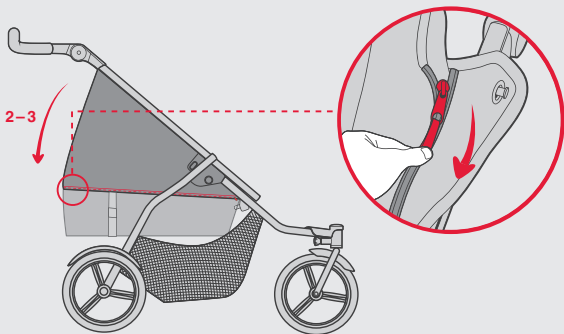

c

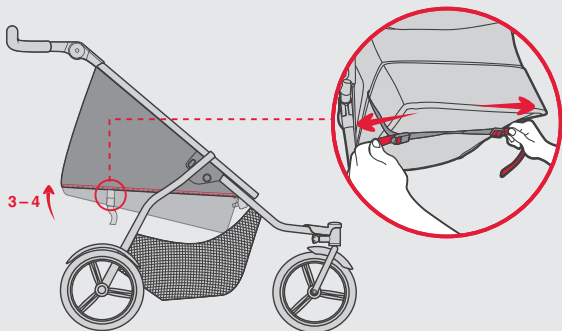

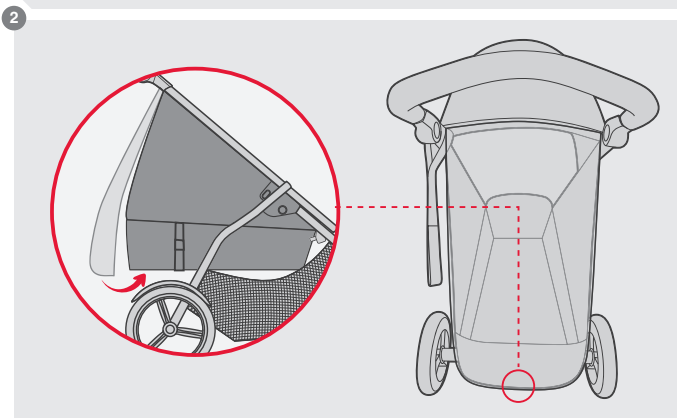
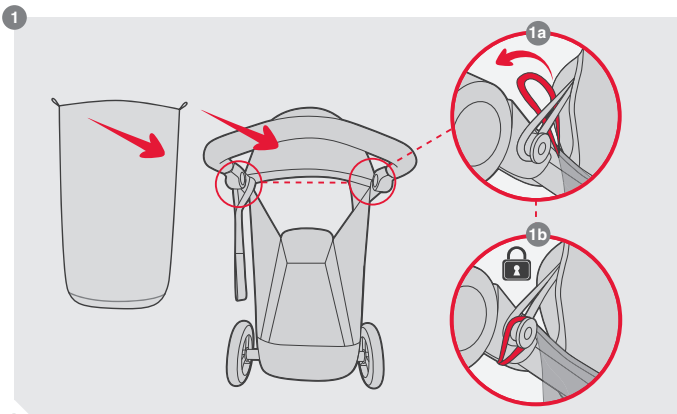



C1 max load
20kg / 44lbs

C2 max load
9kg / 20lbs

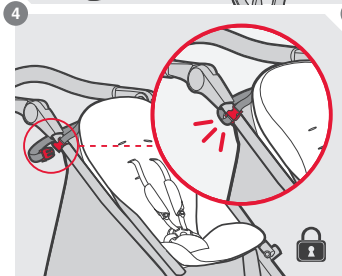
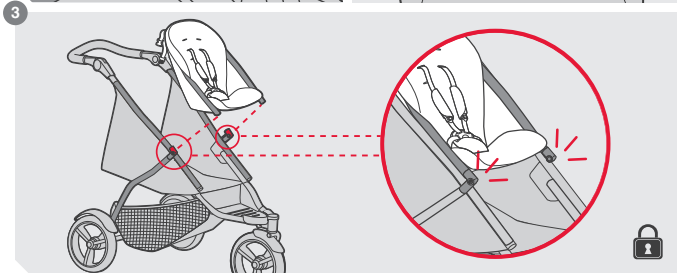
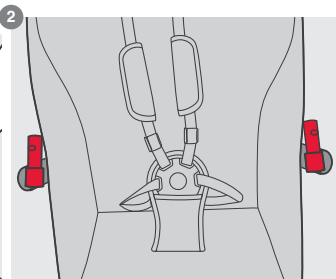
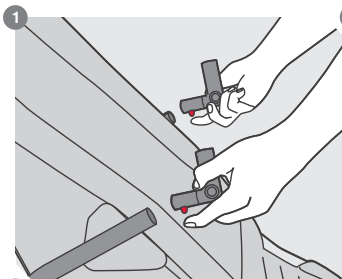



D1 max load
15kg / 33lbs

D2 max load
20kg / 44lbs

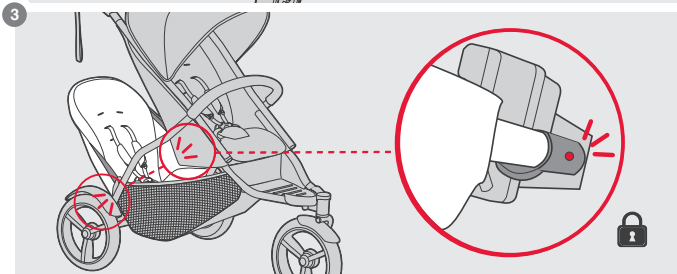
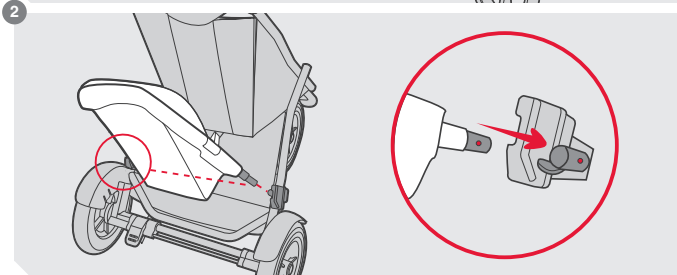
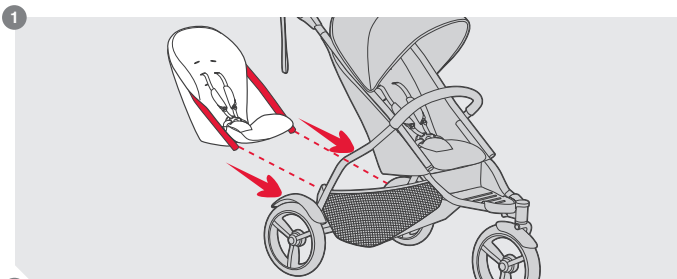

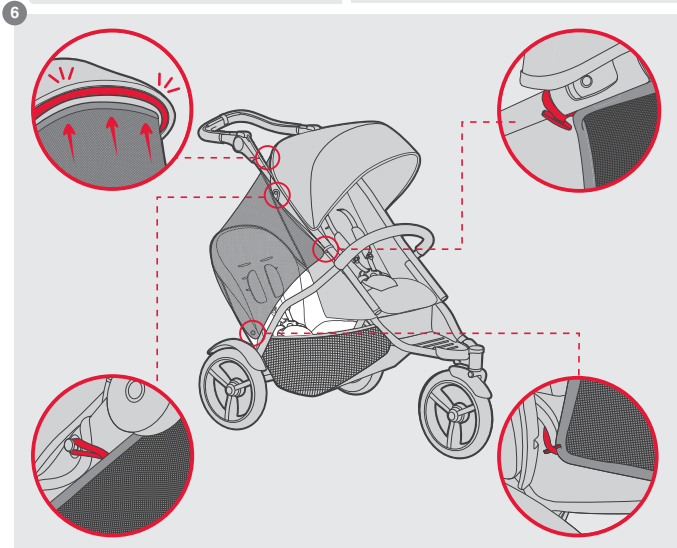
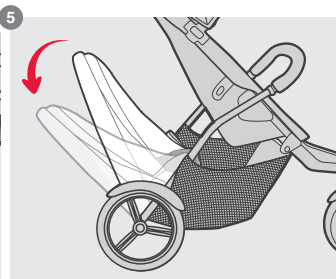
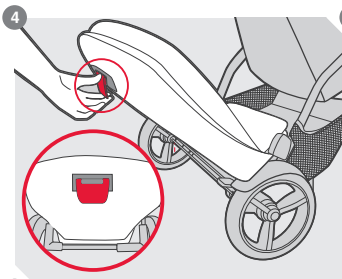





E1

max load

12kg / 26lbs*

*parent facing mode

is for single use only



1

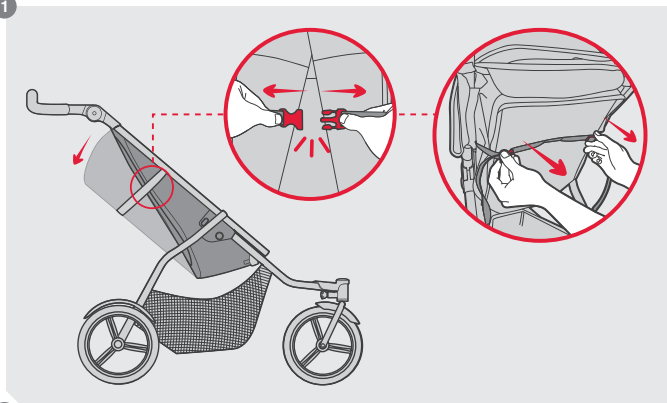

2

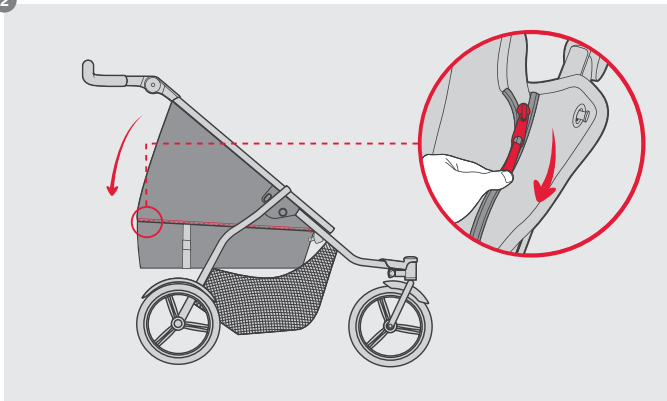



3

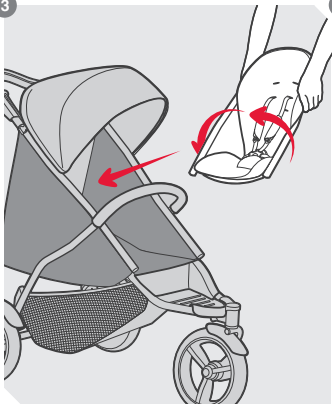

4



5

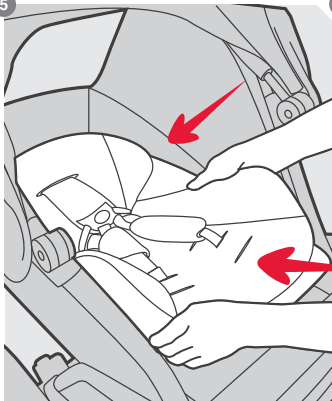

6

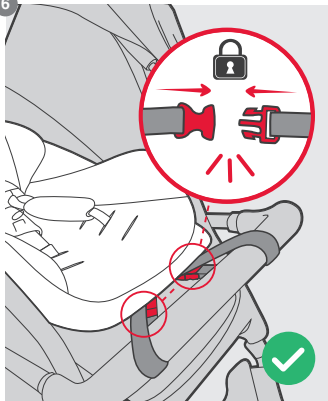







AUS/NZL

phil&teds
102-112 Daniell Street
Newtown, Wellington 6021
New Zealand
+ 64 4 3800 833

USA/CAN

phil&teds USA Inc
221 Jefferson Street
Fort Collins, CO 80524
USA.
1 800 839 4985

GBR

phil&teds
71-73 Victoria St
Windsor, Berkshire
SL4 1EH, United Kingdom
+44 (0) 20-30519264

EUR/FRA

phil&teds
Calle Linaje, 3
Malaga 29001,
Spain
+34 91 290 14 82

CHN

phil&teds
No.10 East Chuangyeyuan
Road, Yangzhou
China
0086-514-87634533

Designed in New Zealand. Made in China
Conçu en Nouvelle-Zélande. Fabriqué en Chine

Conforme aux exigences de sécurité

8182-06

phil&teds®
adapt&survive!™

dot™
care & warnings

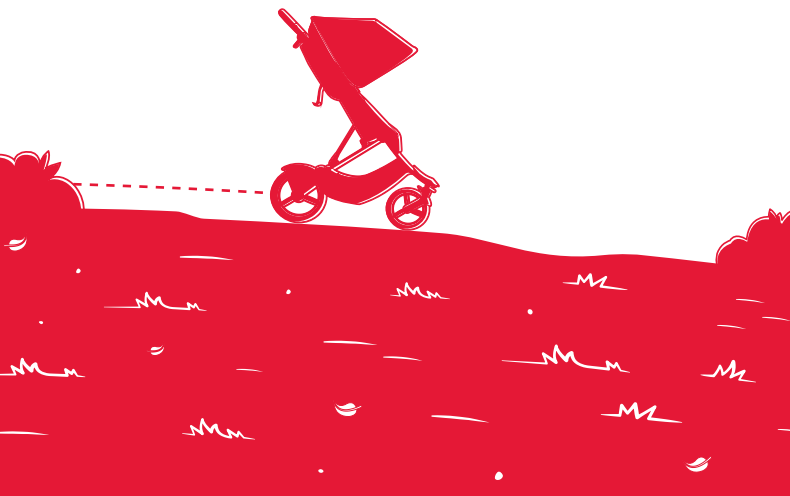

so you chose a
dot™? fine choice
I must say!

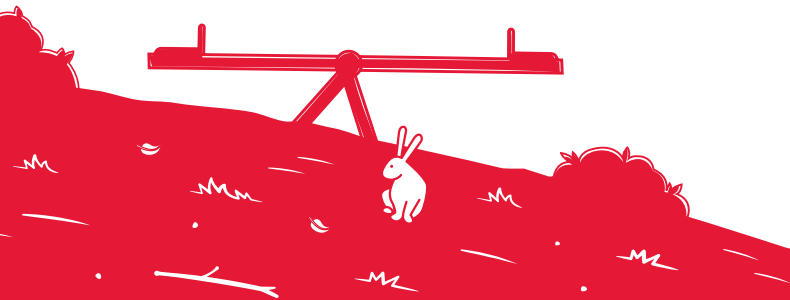



This document contains important information and must be kept for future reference.

Please read thoroughly before use.



for rights & remedies, refer to
www.philanteds.com/warranty

this vehicle is intended for children
from newborn to 5 years.

- main seat – 20kg / 44lbs
- main seat (lie flat) – 9kg / 20lbs
- double kit (back) – 15kg / 33lbs
- double kit (front) – 20kg / 44lbs
- parent facing seat – 12kg / 26lbs

please register your product
purchase online now at

philanteds.com/register

cleaning & caring

check dot™ for cuts & bruises. if your product is damaged in any way, or you're not sure how to use it, please consult our web support (www.philandteds.com/support). here you can get in touch with a local customer care team, made of real live people.

caring for dot™

unlike your children, your dot™ likes to stay clean.

- brush dirt (or cracker crumbs) off the frame & wheels regularly.
- clean frame with non-abrasive household cleaner & a soft cloth & always dry frame if wet.
- dot™ doesn't like sand or sea salt in its crannies (does anyone?), so give dot™ a good rinse after visiting the beach.
- code brown got you down? never fear! dot™ fabric can be sponge cleaned with warm water, using mild natural soap. do not use detergents or bleach on dot™.
- keep dot™ cool & somewhere dark when in storage.
- improper care will void any warranties. do not use dot™ if deterioration is detected or suspected.

--- important information ---

- always load / unload your children on level ground.
- ensure the brake is engaged during the loading & unloading of children.
- do not use stroller on stairs or escalators.
- always use the wrist safety strap.
- excessive wear can reduce effectiveness & safety. parts may need lubrication. inspect essential components for:
 - fraying – especially webbing straps & safety harness.
 - wear – locks, snap fasteners, tyres, plastic & moving parts.
 - safety – locks must not be loose.



important information

aerotech tyres

- tyres are not under warranty, however dot™ uses aerotech tyres which are immune from punctures & eliminate the need for tube replacements.
- with use, the surface of the aerotech tyre can show signs of minor pitting – this is normal for this material, & does not affect performance of the product.

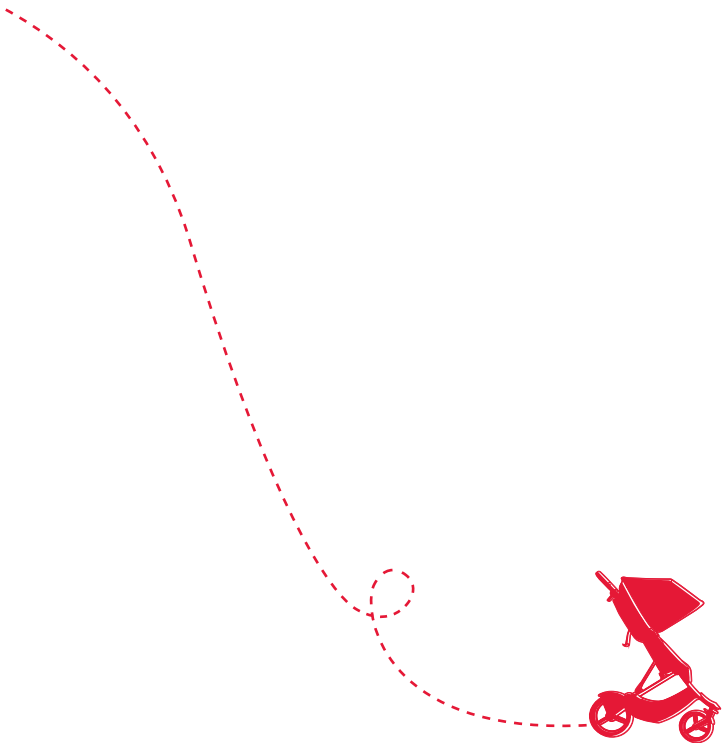



this product complies with requirements applicable in market of sale, refer to philandteds.com/certification

WARNINGS

European safety standard states:

IMPORTANT: Read the instructions carefully before use and keep them for future reference. Your child's safety may be affected if you do not follow these instructions.

- This vehicle is intended for children from newborn up to 5 years and up to a maximum weight of 20kg/44lbs.
- The buggy shall only be used for a maximum of 2 children. Never leave your child unattended.
- Accessories or replacement parts that are not approved by the manufacturer or distributor should not be used.
- Any load attached to the handle and/or back of the backrest and/or the sides of the stroller will affect stability of the stroller. Always use the restraint system.
- Always use the crotch strap in combination with the waist belt.
- Check that the



pram body or seat unit attachment devices are correctly engaged before use. • This product is not suitable for running or skating. • Ensure that all locking devices are engaged before use. • Use a harness as soon as your child can sit unaided. • The parking device shall be engaged during the loading and unloading of children. • The carry handles must be left out of the reclined position when in use (if applicable). • The reclined position is suitable for a child who cannot sit up by itself, roll over and cannot push itself up on its hands and knees. Maximum weight of child in reclined position is 9kg/20lbs. • To avoid injury ensure that your child is kept away when unfolding and folding this product. • Do not let your child play with this product. • It is recommended that the most reclined position be used for new born babies. • Do not place more than 5kg/11lbs in the parcel tray. • Do not add a mattress thicker than 20mm. • A car seat used on a stroller does not replace a cot or a bed. Should your child need to sleep, place it in a suitable pram body, cot or bed.



WARNINGS

American safety standard states:

- Never leave your child unattended in the stroller.
- Always use the safety harness to avoid serious injury from falling or sliding out.
- Always secure all safety harness straps. Child may slip into leg openings and strangle. Never use in a reclined carriage position unless child securely restrained.
- This vehicle is intended for children from newborn to 5 years and up to a maximum weight of 20kg/44lbs.
- To prevent the stroller from becoming unstable, do not place parcels or accessory items anywhere except in the storage basket and pockets provided. Do not hang items such as shopping bags from the frame.
- Do not place more than 5kg/11lbs in the parcel tray.
- Excessive weight may cause a hazardous unstable condition to exist.



WARNINGS

Australia / New Zealand safety standard states:

To avoid injury or death:

- Always apply the brakes whenever the stroller is stationary. Do not leave children unattended.
- Secure the child in the harness at all times.
- Do not carry extra children or bags on this stroller.
- Make sure children are clear of any moving parts if you adjust the stroller.
- Use the harness at all times.
- When not in use disconnect shoulder straps from the waist buckle or strap as harness can form loops that can lead to strangulation.
- Do not use this seat with any other models of stroller.
- It is unsafe to use accessories other than those approved by the vehicles manufacturer.
- Care should be taken if the stroller is used on stairs or escalators.
- The stroller should not be used near an open fire or exposed flame.
- This vehicle is intended for children up to a maximum weight of 20kg/44lbs.
- Do not place more than 5kg/11lbs in



the parcel tray. • Use the tether strap to stop the stroller rolling away. • Do not use the bassinet once the child can sit up unaided. • Maximum weight of child in reclined position is 9kg/20lbs. • The stroller is designed for use on flat or gently sloping surfaces and maybe unstable on higher sloping and uneven surfaces, resulting in the possibility of the stroller tipping over. • Due care should be exercised when folding or unfolding the stroller, as there is potential for fingers or body parts to be injured. • The stroller should only be carried or lifted when it is properly folded. Do not carry or lift the stroller by the wheels, the grab bar or the harness - position your hands at the center of the side frame. • When folding the stroller, please check visually that the automatic frame lock is engaged.



WARNINGS

Canadian safety standard states:

- Always use the safety harness to avoid serious injury from falling or sliding out.
- Do not place more than 5kg/11lbs in the parcel tray.
- The stroller may become unstable if a parcel bag, other than one recommended by the manufacturer, is used.
- The stroller may become unstable if the recommended load is exceeded.
- Take care when folding or unfolding the stroller to prevent your fingers being entrapped.



Vous avez opté pour
une **dot™**? Un choix
judicieux !

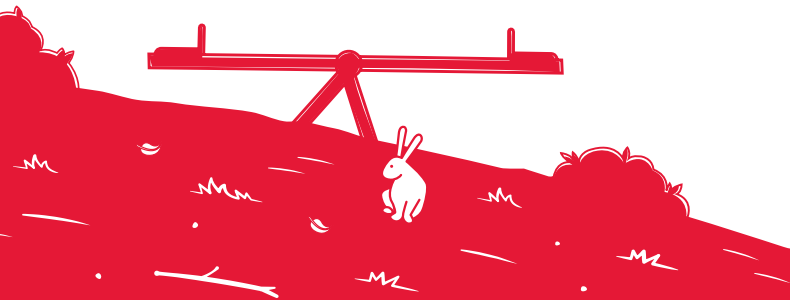



Ce document contient des informations importantes et doit être conservé pour une utilisation ultérieure.

Merci de lire cette notice avec attention avant de commencer l'installation du produit car une installation incorrecte serait dangereuse.



Pour connaître vos droits et recours, merci de consulter www.philanteds.com/warranty

Ce véhicule est conçu pour
des enfants de 0 à 5 ans

- Assise principale – 20kg / 44lbs
- inclinaison à plat – 9kg / 20lbs
- second siège (verso) – 15kg / 33lbs
- second siège (recto) – 20kg / 44lbs
- siège pour une position face aux parents – 12kg / 26lbs

Pour valider votre garantie, veuillez
enregistrer votre produit sur notre site:

philanteds.com/register

précautions & entretien

Examinez avec attention votre produit. Si vous constatez une anomalie sur votre produit ou si vous ne savez pas comment l'utiliser, rendez vous sur le site (www.philandteds.com/support) Vous pouvez contacter une équipe locale de SAV, composée d'interlocuteurs à votre écoute.

Entretien de votre dot™

Contrairement aux enfants, votre dot™ aime rester propre.

- Utilisez régulièrement une brosse pour éliminer la saleté (ou les miettes de gâteau) du châssis et des roues.
- Nettoyez le châssis avec un chiffon doux et un nettoyant ménager non abrasif. Séchez systématiquement le châssis lorsque celui-ci est mouillé.
- La dot™ n'aime pas le sable et le sel de mer dans ses rouages (qui aime ça ?), pensez donc à la rincer soigneusement après vos balades sur la plage.
- Alerte, un cadeau dans la couch! Pas de problème! Les tissus de la dot™ peuvent être nettoyés avec une éponge, en utilisant de l'eau tiède et du savon naturel doux. N'utilisez ni détergent, ni Javel sur la dot™.
- Rangez votre dot™ dans un endroit frais et sombre.
- Un usage inapproprié priverait votre produit de toute garantie. N'utilisez pas votre promenade s'il est détérioré.

Information Importante

- Retirer vos enfants de la poussette que sur terrain plat.
- Mettez les freins lorsque la poussette est immobilisée. Mettez les freins pour sortir un enfant de la poussette ou l'installer.
- Des précautions particulières devront être prises lors de l'utilisation de la poussette dans les escaliers ou les escaliers roulants.
- Passez systématiquement la dragonne autour de votre poignet lorsque vous utilisez la poussette.
- Certaines pièces peuvent avoir besoin d'être lubrifiées.

A surveiller sur les principaux composants:

- Effilochage – tout particulièrement les sangles et le harnais de sécurité.
- Usure – boucles, fermoirs, pneus, pièces en plastique, zips et parties amovibles.
- Sécurité – les boucles ne doivent pas être lâches.



information Importante

Aerotech pneus

- Les pneus ne sont pas sous garantie, mais comme la dot™ est équipée de pneus anti-crevaisons Aerotech, pas de chambre à air à changer.
- Avec le temps, la surface des roues Aerotech peut montrer des signes mineurs d'usure, ce qui est normal, mais elle n'affecte pas la performance du produit.

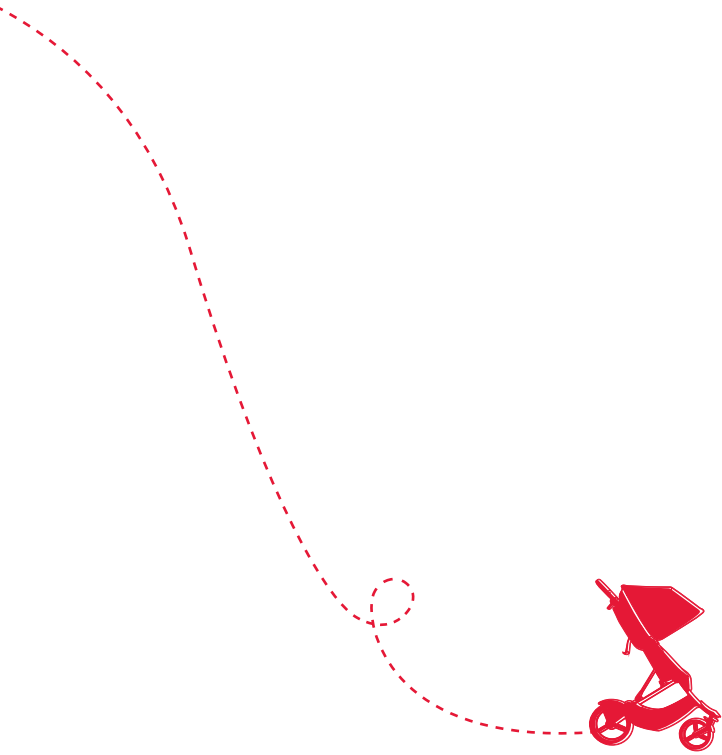



Obligations normatives et légales du marché,
consulter www.philandteds.com/certification

WARNINGS

La norme européenne stipule:

**IMPORTANT – À CONSERVER POUR CONSULTATION
ULTÉRIEURE – À LIRE SOIGNEUSEMENT**

**Lire ces instructions avec attention avant utilisation
et les conserver pour les besoins futurs. Si vous ne
respectiez pas ces instructions, la sécurité de votre
enfant pourrait en être affectée.**

- Cette poussette est conçue pour des enfants de la naissance à 5 ans et jusqu'au poids maximum de 20kg/44lbs.
- La poussette ne peut transporter plus de 2 enfants.
- **AVERTISSEMENT** - S'assurer que tous les dispositifs de verrouillage sont correctement enclenchés avant utilisation.
- **AVERTISSEMENT** Le fait d'accrocher au guidon une charge influe sur la stabilité de la poussette.



• AVERTISSEMENT Ne jamais utiliser l'entrejambe sans la ceinture de maintien. • AVERTISSEMENT Vérifier que les dispositifs de fixation de la nacelle ou du siège sont correctement enclenchés avant usage. • AVERTISSEMENT Ne jamais laisser votre enfant sans surveillance. • AVERTISSEMENT S'assurer que tous les dispositifs de verrouillage sont enclenchés avant utilisation. • AVERTISSEMENT Pour éviter toute blessure, maintenir votre enfant à l'écart lors du dépliage et du pliage du produit. • AVERTISSEMENT Ne pas laisser votre enfant jouer avec ce produit. • AVERTISSEMENT Utiliser un harnais dès que l'enfant peut tenir assis tout seul. • AVERTISSEMENT Toujours utiliser le système de retenue. • AVERTISSEMENT Vérifier que les dispositifs de fixation de la nacelle, du siège ou du siège-auto sont correctement enclenchés avant utilisation. • AVERTISSEMENT Ce produit ne convient pas pour faire du jogging ou des promenades en rollers. • Ce produit convient pour les enfants ne pouvant pas tenir assis seuls, ni se retourner et se relever sur leurs mains et leurs genoux. Poids maximal de l'enfant : 9kg/20lbs.



WARNINGS

La norme canadienne stipule:

- Ne laissez jamais votre enfant dans la poussette sans surveillance.
- Veillez à toujours utiliser le harnais afin d'éviter les risques de chute ou de glissement.
- Ne pas placer une charge supérieure à 5kg/11lbs dans le panier de la poussette.
- Afin d'éviter le déséquilibre de la poussette, n'utilisez aucun panier autre que celui recommandé par le fabricant.
- La poussette pourrait devenir instable si la charge supportée était supérieure à celle recommandée.
- Attention à ne pas vous coincer les doigts lorsque vous pliez /dépliez la poussette.





Du hast dir also einen
dot™? ausgesucht? Eine
ausgezeichnete Wahl!

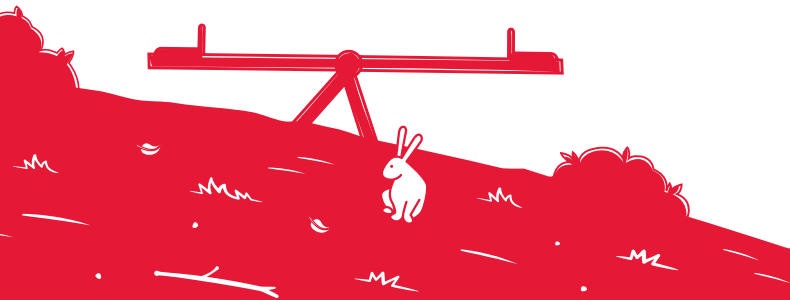



Diese Anleitung enthält wichtige Informationen und muss zur späteren Einsichtnahme sorgfältig aufbewahrt werden.

Bitte lesen Sie sich diese Bedienungsanleitung sorgfältig und vollständig durch, da bei unsachgemäßem Einsatz die Gefahr von schweren Personen- oder Sachschäden besteht.



Besuchen Sie: www.philandteds.com/warranty
für Verbraucherrechte und Gewährleistungen

Dieser Kinderwagen ist für Neugeborene bis zu einem Alter von 5 Jahren geeignet.

- Hauptsitz – 20kg / 44lbs
- flach – 9kg / 20lbs
- Zweitsitz (Hinten) – 15kg / 33lbs
- Zweitsitz (vorne) – 20kg / 44lbs
- Zum Elternteil ausgerichteter Sitz – 12kg / 26lbs

Bitte registrieren Sie Ihr Produkt durch unsere online Registrierung bei:

philanteds.com/register

Reinigung & Pflege

Überprüfen Sie das Produkt auf Kratzer & Beulen. Falls das Produkt beschädigt ist oder Sie nicht sicher sind, wie Sie es in Gebrauch nehmen, besuchen Sie uns im Internet www.philandteds.com/support
Hier kannst du Verbindung zu einem lokalen Kundendienstteam aufnehmen, das aus echten Leuten besteht.

Pflege des dot™

Anders als Kinder möchte der dot™ gerne sauber bleiben.

- Entferne Schmutz (und Kekskrümel) regelmäßig vom Rahmen und den Rädern.
- Reinige den Rahmen mit einem scheuerfreien Reinigungsmittel und einem weichen Tuch. Trockne den Rahmen immer gut ab.
- dot™ mag keinen Sand und kein Meersalz in seinen Ritzen (wem gefällt das schon?). Spüle ihn nach einem Strandbesuch bitte gut ab.
- Hat die Windel mal wieder versagt? Keine Angst! Das Material von dot™ kann mit einem Schwamm und einer warmen, milden Seifenlösung gereinigt werden. Zum Säubern von dot™ dürfen keine Reinigungs- oder Bleichmittel verwendet werden.
- dot™ sollte an einem kühlen und dunklen Ort gelagert werden.

Wichtige Information

- Unsachgemässer Gebrauch lässt die Garantierechte erlöschen. Benutzen Sie den dot™ nicht, wenn Sie eine Beschädigung entdeckt haben oder deren Vorhandensein vermuten.
- Beim herausnehmen des Kindes stellen Sie sicher dass ihr Kinderwagen steht auf ebenen Boden.
- Verwenden Sie beim Parken eines Buggys stets die Bremsvorrichtung. Verwenden Sie beim Hineinsetzen bzw. Herausholen von Kindern stets die Bremsvorrichtung.
- Seien Sie bei der Benutzung des Buggys auf Treppen und Rolltreppen besonders vorsichtig.
- Während der Benutzung des Buggys sollte immer das Handband angelegt sein.
- Ausgiebige Benutzung kann die Funktionalität und die Sicherheit beeinträchtigen. Einige Teile müssen von Zeit zu Zeit nachgeölt werden. Überprüfen Sie wichtige Bestandteile auf:
 - Verschleiß – besonders Gurte und Sicherheitsgurte.
 - Abnutzung – Verschlüsse, Klick-Verschlüsse, Reifen, Plastikteile und sich bewegende Teile.
 - Sicherheit – Sicherheitsverschlüsse müssen immer fest sitzen.



Wichtige Information

Aerotech Reifen

- Die Reifen werden nicht von unserer Garantie abgedeckt. dot™ ist jedoch mit pannensicheren Aerotech-Reifen ausgerüstet, deren Schläuche nicht ausgewechselt werden müssen.
- Die Aerotech Reifen können bei starker Verwendung Anzeichen von geringem Lochfraß aufzeigen. Dies ist normal und beeinträchtigt die Leistungsfähigkeit des Produktes nicht.

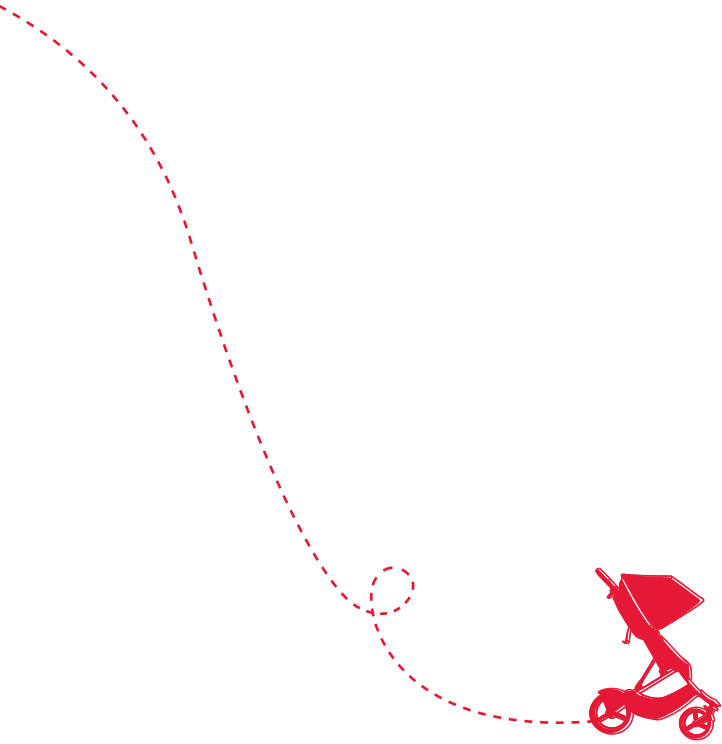



Der dot™ erfüllt folgende Normen des Arbeitsmarktes,
siehe: www.philandteds.com/certification

WARNUNGEN

- Nur mit phil&teds dot™ Zubehör benutzen.

WARNUNGEN

Der europäische Sicherheitsstandard besagt:

Lesen Sie die Gebrauchsanweisung sorgfältig vor Gebrauch und bewahren Sie sie zum Nachschlagen auf. Die Sicherheit Ihres Kindes kann beeinträchtigt werden, wenn Sie diese Gebrauchsanweisung nicht befolgen.

- Never leave your child unattended in the stroller.
- Always becoming unstable, do not place parcels or accessory
- Dieser Kinderwagen ist für Kinder im Alter von Neugeborenen bis zu 5 Jahren oder einem Maximalgewicht von 20kg/44lbs zugelassen.
- Das



Kind unbeaufsichtigt im Kinderwagen zu lassen, kann gefährlich sein. • Der Buggy darf maximal für 2 Kinder benutzt werden. • Zubehör oder Ersatzteile, die nicht vom Hersteller empfohlen werden, dürfen nicht eingesetzt werden. • Alle Lasten, die am Griff befestigt werden, beeinträchtigen die Stabilität des Buggys. • Verwenden sie den Gurt zwischen den Beinen des Kindes immer in Verbindung mit dem Hüftgurt. • Überprüfen Sie, ob Aufsatz und Sitz des Buggys korrekt und sicher befestigt sind, bevor Sie ihn einsetzen. • Dieses Produkt ist nicht geeignet zum Joggen oder Skaten. • Stellen Sie sicher, dass alle Sicherheitsverschlüsse sicher geschlossen sind, bevor Sie den Kinderwagen gebrauchen. • Benutzen Sie den Sicherheitsgurt sobald Ihr Kind alleine sitzen kann. • Überschreiten Sie die Maximallast der Gepäckablage von 5kg/11lbs nicht. • Benutzen Sie keine zusätzliche Einlage oder Matratze, dicker als 20mm. • Beim Hineinsetzen oder Herausheben des Kindes müssen die Bremsen angezogen und arretiert sein.



¿Así que te has
decantado por la
dot™? ¡Qué elección
más sabia!

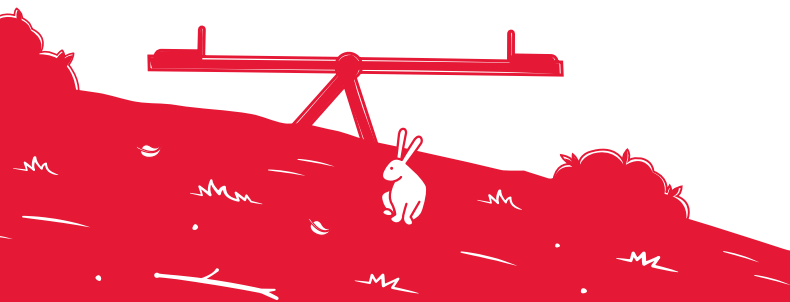



Este documento contiene información importante y debe ser guardado para futuras referencias.

Por favor lee cuidadosamente antes de comenzar la instalación. Una instalación incorrecta puede ser peligrosa



Para mas información visita
www.philandteds.com/warranty

Este vehículo está destinado para niños desde recién nacidos hasta los 5 años de edad.

- asiento principal – 20kg / 44lbs
- tumbado – 9kg / 20lbs
- double kit (Atras) – 15kg / 33lbs
- double kit (Delantera) – 20kg / 44lbs
- mirando a los papás – 12kg / 26lbs

Please Registra tu compra del producto a través de nuestro registro de garantía en línea visitando:

philanteds.com/register

limpiar & cuidar

Comprueba si el dot™ tiene cortes y moratones. Si el producto está dañado de alguna forma, o si no sabes con certeza cómo usarlo, ponte en contacto (www.philandteds.com/support) desde donde podrás tener acceso al equipo de servicio al cliente local. Desde aquí puedes ponerte en contacto con el equipo de atención al cliente, compuesto por personas de carne y hueso.

Cuidar a tu dot™

A diferencia de los niños, al dot™ le gusta estar limpio.

- Quita con un cepillo la suciedad (o las miguitas de pan) del chasis y las ruedas con frecuencia.
- Utiliza un limpiador doméstico no abrasivo y un trapo suave para limpiar el chasis. Seca el chasis siempre que se moje.
- A la dot™ no le gusta que haya arena ni sal de mar en sus recovecos (¿y a quién sí?): aclárala bien después de ir a la playa.
- ¿El bebé ha plantado un pino? ¡No pasa nada! La tela de la dot™ se puede lavar con una esponja, agua tibia y un jabón suave y natural. No utilices ni detergentes ni lejía en la dot™.
- Guarda la dot™ en un lugar fresco y oscuro.
- Cuidado incorrecto anulará cualquier garantía. No utilice dot™ si se detecta un deterioro o sospecha.

----- Información importante -----

- Siempre retire su hijo a nivel del suelo.
- aplica los frenos al aparcar la silla de paseo. Aplica los frenos al meter o sacar a los niños.
- Ten cuidado si utilizas la silla de paseo en escaleras normales o mecánicas.
- Siempre use la correa alrededor de su muñeca al usar el cochecillo.
- Hay partes que pueden necesitar lubricante. Inspeccione los componentes esenciales:
 - Deshilachado – especialmente en las costuras de las correas y del arnés de seguridad.
 - Desgaste por uso – seguros, neumáticos, partes de plástico y partes móviles.
 - Seguridad – los seguros nunca deben de estar flojos.



Información importante

Aerotech Neumático

- Los neumáticos no están cubiertos por la garantía, pero la dot™ lleva neumáticos Aerotech, que no se pinchan y con los que no hay que cambiar las cámaras.
- Con el uso, la superficie del neumático Aerotech puede mostrar signos de picaduras menores – esto es normal para este material, y esto no afecta al rendimiento del producto.

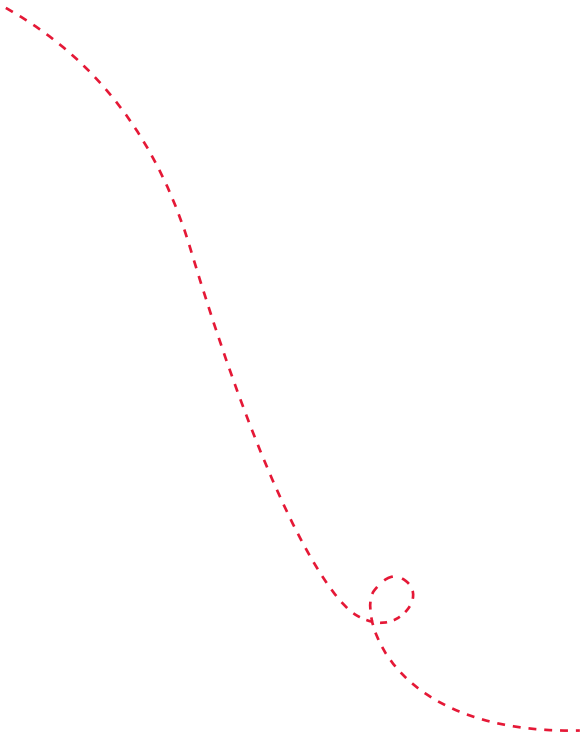



El dot™ cumple con los requisitos aplicables en el mercado para la venta, consulte www.philandteds.com/certification

ADVERTENCIAS

El Estándar de Seguridad Europeo dicta:

Lee las instrucciones cuidadosamente antes del uso y consérvalas para futura referencia. La seguridad del niño puede ser afectada si no se siguen estas instrucciones.

- Este vehículo está planeado para niños de recién nacido a 5 años y peso máximo de 20kg/44lbs.
- Puede ser peligroso dejar al niño sin supervisión.
- El coche de paseo debe usarse para un máximo de 2 niños.
- Accesorios o partes de repuesto que no sean aprobados por el fabricante o distribuidor autorizado, no deben usarse.
- Asegure todos los seguros estén puestos antes de su uso.
- Siempre use la correa de la entrepierna en combinación con el cinturón.
- Cheque que el cuerpo del coche y los dispositivos de la unidad del asiento



estén correctamente ajustados antes de su uso. • Este producto no es para correr o patinar. • Cualquier carga en el manubrio, afecta la estabilidad del coche de paseo. Use el arnés tan pronto como su niño pueda sentarse sin ayuda. • No ponga más de 5kg/11lbs en la canastilla. • No agregar colchon mas grueso a 20mm. • El dispositivo de estacionamiento debe estar puesto durante la carga y descarga del niño.



Dus je hebt een
dot™? gekozen?
Goede keus!

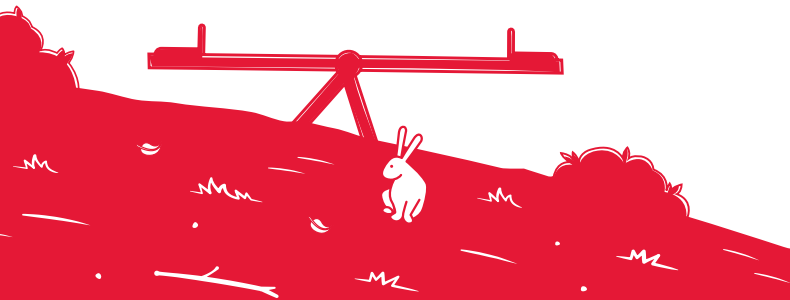



**This document contains important
Dit document bevat belangrijke
informatie en moet worden bewaard
voor toekomstig gebruik.**

**Gelieve aandachtig door te lezen
voordat u begint met de installatie
aangezien onjuiste installatie
gevaarlijk kan zijn.**



Voor de rechten en hulp bij eventuele problemen,
ga naar www.philanteds.com/warranty

Dit voertuig is bedoeld voor kinderen
vanaf geboorte tot 5 jaar.

- hoofdzitplaats – 20kg / 44lbs
- Plat liggen voor pasgeborene – 9kg / 20lbs
- dobbelsett (Tilbake) – 15kg / 33lbs
- dobbelsett (front) – 20kg / 44lbs
- naar de ouder gericht zitje – 12kg / 26lbs

Registreer uw aankoop door via
onze online product registratie op:

philanteds.com/register

shoonmaken & verzorgen

Controleer of je dot™ geen beschadigingen heeft. Als dit toch het geval is of je weet niet hoe de dot™ te gebruiken, neem dan direct contact op met web-support (www.philandteds.com/support).

Verzorging van je dot™

Kinderen vinden het niet erg om vies te worden, je dot™ wel.

- Borstel vuil (of kruimels) regelmatig van het frame en de wielen af.
- Reinig het frame met een niet-schurend reinigingsmiddel en een zachte doek. Droog het frame altijd af als het nat is.
- Dot™ houdt niet van zand of zeezout in hoekjes en gaatjes (net als iedereen!), dus spoel dot™ goed af als je naar het strand bent geweest.
- Verdacht luchtje? Geen angst! De stof van dot™ kan met een spons en warm water en een milde natuurlijke zeep worden gereinigd. Gebruik geen wasmiddelen of bleekmiddel op dot™.
- Berg dot™ in een koele & donkere ruimte op.
- Door onzorgvuldig gebruik vervallen alle garanties. Gebruik de dot™ niet wanneer verval of het vermoeden ervan intreedt.

Belangrijke Informatie

- Laad uw kinderen altijd uit op een vlakke ondergrond.
- Gebruik tijdens het parkeren van de buggy altijd de rem. Zet de buggy altijd op de rem voordat je de kinderen erin zet of eruit haalt.
- wees voorzichtig als je de buggy gebruikt op trappen en roltrappen.
- Doe de polsband altijd om uw pols als je de buggy gebruikt.
- Buitensporige slijtage kan ten koste gaan van de effectiviteit en de veiligheid. Het kan nodig zijn de onderdelen regelmatig te smeren.

Controleer essentiële onderdelen op:

- rafelen – vooral geweven riemen en veiligheidsharnas.
- Slijtage – vergrendelingen, klikbevestigingen, banden, kunststof onderdelen, ritsen en bewegende delen.
- Veiligheid – vergrendelingen moeten vastzitten.



Belangrijke Informatie

Aerotech Banden

- De banden vallen niet onder de garantie, maar dot™ heeft Aerotech banden, waar geen gaatjes in kunnen komen, waardoor vervanging van binnenbanden niet nodig is.
- Er kunnen wat kleine pitjes ontstaan op het oppervlak van de Aerotech banden na gebruik. Dit is normaal en dit heeft geen invloed op de prestatie van het product.

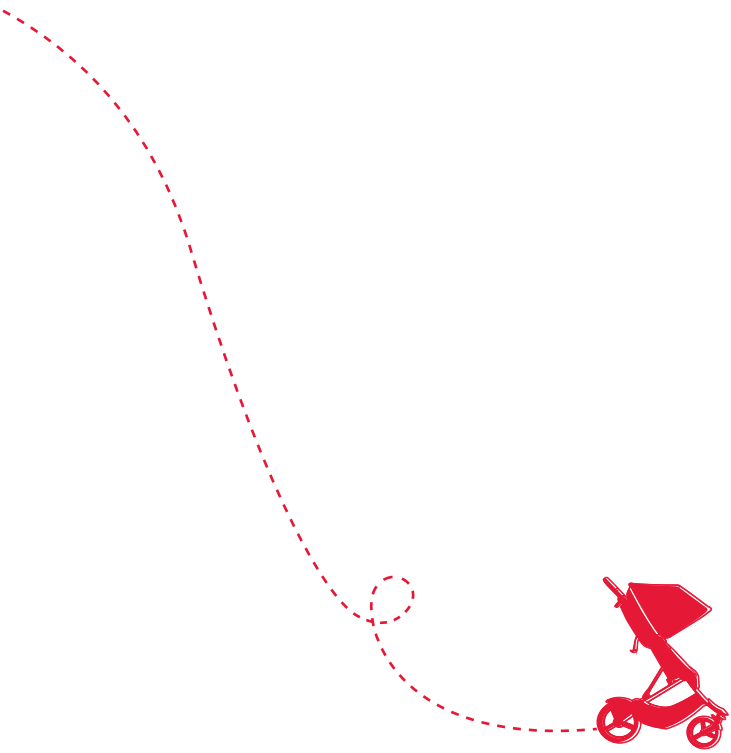



et dot™ zitje voldoet aan alle eisen die gelden in het land van verkoop, zie hiervoor ook www.philandteds.com/certifications

WAARSCHWINGEN

European Safety Standard:

Lees de instructies aandachtig door en bewaar de instructies bij je buggy om ze evt later na te kunnen slaan. Oneigenlijk gebruik of het niet opvolgen van alle veiligheidsvoorschriften kan tot verwondingen leiden.

- Deze buggy is bedoeld voor kinderen tot 5 jaar of met een maximum gewicht van 20kg/44lbs.
- Het kan gevaarlijk zijn om kinderen zonder toezicht te laten.
- De buggy wordt enkel gebruikt voor maximaal 2 kinderen.
- Accessoires of reserve onderdelen welke niet zijn goedgekeurd door de fabrikant of distributeur mogen niet worden gebruikt.
- Elke belasting van de duwstang heeft invloed op de stabiliteit van de buggy.
- Gebruik de kruisgordel altijd in combinatie met de buikgordel.
- Controleer

of het frame en zitje correct zijn afgesteld alvorens de buggy te gebruiken. • Deze buggy is niet geschikt om mee te rennen of skaten. • Zorg voordat je de buggy gaat gebruiken dat alle vergrendelingsvoorzieningen vastzitten. • Gebruik het veiligheidsharnas zodra uw kind zonder hulp kan zitten. • Doe niet meer dan 5kg/11lbs in het boodschappenmandje. • Geen matras plaatsen die dikker is dan 20mm. • Zet de buggy altijd op de parkeerrem voordat je de kinderen erin zet of eruit haalt.

© Phil and Teds Most Excellent Buggy Company Ltd 2010.

We (Phil and Teds Most Excellent Buggy Company Ltd) own the intellectual property rights in our brands, designs and inventions featured in this publication. These include, without limitation, the Mountain Buggy, life without limit, and INLINE trade marks and product names. We actively pursue people who infringe our intellectual property.

©Phil & Teds Most Excellent Buggy Company Ltd 2010.

Nous (Phil and Teds Most Excellent Buggy Company Ltd) sommes détenteurs de tous les droits de propriété intellectuelle associés à nos marques, modèles et inventions mentionnés dans le présent document. Ceux-ci incluent, sans que cela soit limitatif, les marques commerciales the Mountain Buggy, life without limit, INLINE trade marks et product names. Nous engageons des poursuites contre tous ceux qui enfreignent nos droits de notre propriété intellectuelle.

© Phil and Teds Most Excellent Buggy Company Ltd 2010.

Wir (Phil and Teds Most Excellent Buggy Company Ltd) sind Eigentümer aller geistigen Eigentumsrechte bezüglich unserer in dieser Veröffentlichung aufgeführten Marken, Designs und Erfindungen. Diese schließen die Marken und Mountain Buggy, life without limit, INLINE trade marks und product names. Personen, die unsere Eigentumsrechte verletzen, werden von uns aktiv verfolgt.

© Phil and Teds Most Excellent Buggy Company Ltd 2010.

Nos pertenecen a nosotros (Phil and Teds Most Excellent Buggy Company Ltd) los derechos de propiedad intelectual de nuestras marcas, diseños e inventos mostrados en la presente publicación. Se incluyen, sin limitarse a, las marcas the Mountain Buggy, life without limit, INLINE trade marks e product names. Iniciaremos acciones legales contra aquéllos que violen nuestra propiedad intelectual.

© Phil and Teds Most Excellent Buggy Company Ltd 2010.

Wij (Phil and Teds Most Excellent Buggy Company Ltd) bezitten de intellectuele eigendomsrechten op onze merken, ontwerpen en uitvindingen die in deze publicatie worden vermeld. Dit zijn, zonder beperking, de handelsmerken the Mountain Buggy, life without limit, and INLINE trade marks en de product names. We dienen daadwerkelijk een aanklacht in tegen degenen die inbreuk maken op ons intellectueel eigendomsrecht.

© Phil and Teds Most Excellent Buggy Company Ltd 2010.

Vi (Phil and Teds Most Excellent Buggy Company Ltd) äger upphovsrätten till de varumärken, designer, former och uppfinningar som visas i denna publikation. Dessa inkluderar men är ej begränsade till varumärkena Mountain Buggy, life without limit och INLINE samt produktnamnen. Vi förföljer aktivt de som kränker vår upphovsrätt.

phil&teds[®]

adapt&survive![™]

AUS/NZL

phil&teds
102-112 Daniell Street
Newtown, Wellington 6021
New Zealand
+ 64 4 3800 833

EUR

phil&teds Spain
Calle Casas de Campos
N°15, 3ª Planta
Malaga 29001, Spain
+34-91-290 14 82

USA/CAN

phil&teds USA Inc
221 Jefferson Street
Fort Collins, CO 80524
USA.
1 800 839 4985

FRA

phil&teds France
15 rue Gertrude Bell
56000 Vannes
FRANCE
+ 33 (0) 2 97 44 88 26

GBR

phil&teds UK
71-73 Victoria St
Windsor, Berkshire
SL4 1EH, United Kingdom
+44 (0) 20-30519264

CHN

phil&teds China
No.10 East Chuangyeyuan
Road, Yangzhou
China
0086-514-87634533

Designed in New Zealand. Made in China
Conçu en Nouvelle-Zélande. Fabriqué en Chine

Conforme aux exigences de sécurité

8183-04