

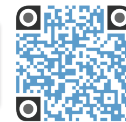

WR48A-D2

Worktop 48" Refrigerator with One Door and Two Drawers



WR48A-D2
02/05/20
Item # 13520

W x D x H
48" x 30" x 40"*
*with 6" casters



Item #: _____
Project: _____
Qty: _____
AIA#: _____

Features

- ▶ Engineered to maintain NSF-7 temperatures in 100°F ambient.
- ▶ Stainless steel exterior front, sides, and top with stainless steel interior sides, back, and floor
- ▶ Front breathing air flow design
 - Environmentally friendly R290 hydrocarbon refrigerant
 - Cabinet, doors and drawers are insulated with 2" CFC free, foamed in place polyurethane
 - Exclusive "stepped" door design to protect door gasket
 - Extruded aluminum flush mount door handle
 - Field reversible doors
 - Spring assisted self-closing doors with stay open feature
 - Drawer slides are constructed of 16 gauge stainless steel with acetal rollers
 - Drawer frames are formed of 16 gauge stainless steel and securely fastened in the cabinet
 - Top and bottom drawers will accommodate (1) 1/2 size pan & (1) 1/3 size pan. In addition, top drawer will also accommodate (1) 1/4 size pan and (1) 1/6 size pan. Alternate pan orientation (top drawers only) provides (1) full size pan positioned longways front to back and (3) 1/9 size pans.
 - Magnetic door/drawer gasket is easily removable for cleaning
 - E-coated evaporator coil
 - One epoxy coated shelf per door section is standard
 - Anodized aluminum shelf supports adjustable in 1/2" increments
 - Standard with 6" casters (two with brakes)
 - 10 ft. cord and plug



Dimensions / Capacity

Interior Storage Capacity (CF)	13.66 ft ³
Interior Storage Capacity (CF) (AHAM)	12 ft ³
Overall Width x Depth (including 1" bumper)	48" x 31"
Height (including 6" casters)	40"
Door Opening Width x Height	19.5" x 23"
Depth with Door Fully Open (including 1" bumper)	52.5
Depth with Drawer Fully Open (including 1" bumper)	52"
Adjustable shelves / Shelf Dimensions (W x D)	1 / 21.38" x 16"
Crated Weight	295 lbs.
Crated Length x Width x Height	51" x 32" x 40.25"

Two-Section WR48A-D2

Electrical / Refrigeration

Voltage	115/60/1
HACR Breaker	15.0 Amps
Electrical Connection (NEMA)	5-15P
Voltage Range	104-126
Ambient Temp. Range	45° to 100°F
Control Setpoint Range	32° to 52°F
Amperage	2.6
Energy Consumption (kWh/day) @NSF	1.4
Heat Rejection (BTU/Hr.) @NSF	203
Approx. Nominal Compres. BTU/HR (HP)	988(1/6HP)
Refrigerant / Charge Amount (oz)	R290 (3.0 oz)

Two-Section WR48A-D2

Options

- 2.25" Casters
- 4" Casters
- Overshelves
- Stainless steel back
- Drawer divider bars
- Stainless steel shelves

Warranty

* 3 Year - parts and Labor on entire machine.
5 Year - Parts on Compressor
Valid in United States, Canada, Puerto Rico and U.S. Territories. Contact factory for warranty in other countries.

Note: Made to order. Allow 4-6 weeks.

Door or drawer can be located in any section of the cabinet. Location must be indicated at time of ordering.

Hoshizaki reserves the right to change specifications without notice.



WR48A-D2

Worktop 48" Refrigerator
with One Door and Two Drawers



WR48A-D2
02/05/20
Item # 13520

FRONT VIEW

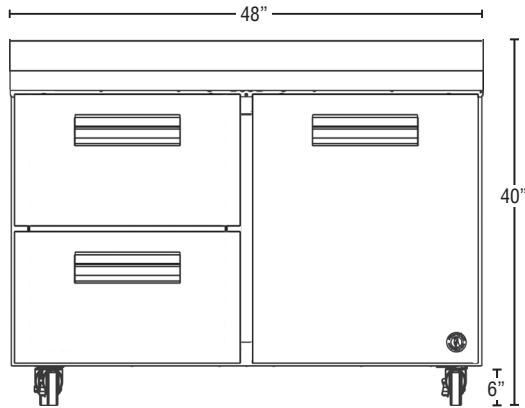

SIDE VIEW

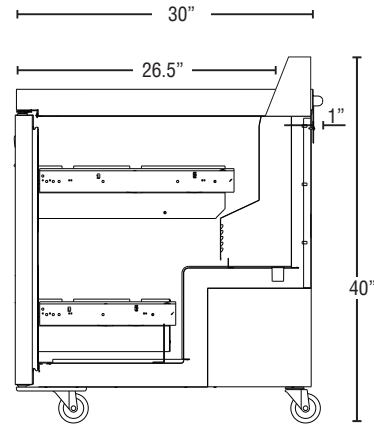

PLAN VIEW

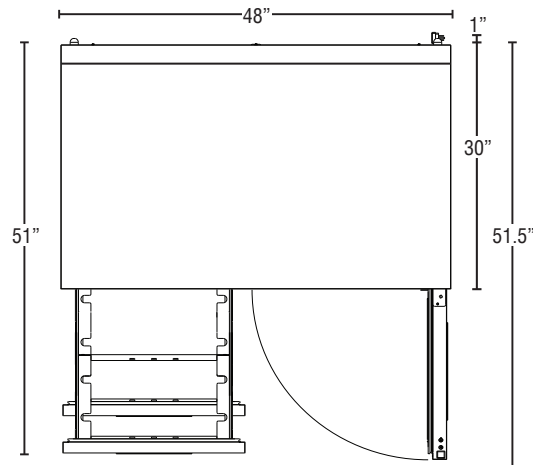

Cabinet Construction

The exterior cabinet top, front, and sides, are constructed of high quality stainless steel. The exterior back and bottom are constructed of coated steel. The cabinet interior features stainless steel back, sides, and floor with an ABS top. One heavy duty epoxy coated shelf per section is standard. Mounted on anodized aluminum pilasters the shelves are adjustable in 1/2" increments. Cabinet walls and doors are insulated with 2" of environmentally friendly, CFC free, foamed in place polyurethane. 4" polyolefin, stem casters (two with brakes) are standard.

Drawer Construction

Drawer fronts are constructed of high grade stainless steel inside and out and are insulated with CFC free foamed in place polyurethane. The top drawer will also accommodate (1) 1/2 size pan & (1) 1/3 size pan 6" deep at the front of the drawer opening and provide capacity for (1) 1/4 size pan and (1) 1/6 size pan 4" deep in the rear of the drawer. HS-5432 is recommended for this configuration. Drawer frames are formed of heavy duty stainless steel and securely fastened in the cabinet. The drawer slides are heavy duty stainless steel with acetal rollers to prevent metal to metal contact between the drawer slides and reduce wear. The drawer slides have a dynamic load capacity of 175 lbs. and have been life tested (fully loaded) three hundred thousand openings and closings without showing significant wear. The flush mount handles are constructed of extruded aluminum. Snap-in magnetic drawer gaskets are durable and easily removed for cleaning.

Door Construction

Doors are constructed of high grade stainless steel exterior with an ABS interior liner. Hoshizaki's exclusive "stepped" design protects the gasket while product is removed from the cabinet. Doors are provided with a one piece, extruded aluminum, flush mount handle. Spring assisted self-closing doors are equipped with a stay open feature past 90 degrees. Snap-in magnetic door gaskets are durable and easily removed for cleaning. Field reversible door hinging is standard and does not require a kit.

Refrigeration System

The high efficiency refrigeration system is self-contained with an E-coated evaporator for extended life. Condensate removal is accomplished with an energy efficient non-electric evaporation system. A capillary tube controls the flow of environmentally friendly R290 refrigerant through the evaporator. Refrigeration system utilizes an "off cycle" defrost to eliminate any ice on the evaporator coil. 115 volt units are equipped with a ten foot cord and plug (20.0 amps or less).