



INSTALLATION INSTRUCTIONS

MECHANICAL ADVANCE IGNITION FOR HARLEY DAVIDSON® BIG TWINS Part # 20100 (Dual Fire) & 20200 (Single Fire)

READ THESE INSTRUCTIONS COMPLETELY BEFORE BEGINNING INSTALLATION!

Check the contents of the kit:

Mechanical Advance Ignition Module
Trigger rotor
3x Spade Terminal
Magnet
Spacer kit

STEP #1: REMOVE STOCK IGNITION COMPONENTS

CONVERTING POINTS IGNITION TO COMPU-FIRE IGNITION

Refer to Figure 1.

1. Turn the ignition switch to the "off" position.
2. Disconnect the ground (-) cable from the battery.
3. Remove the optional cover (1), the ignition side cover (2) and gasket (3).
4. Remove the two standoffs (4) and washers (5) that secure the point plate (6) to the ignition housing. Disconnect the wire going to the points and remove the plate assembly.
5. Remove the bolt (7) that holds the advance assembly (9) to the engine. Remove the breaker points cam piece (8) only. **MAKE SURE THE ADVANCE ASSEMBLY (9) REMAINS FULLY SEATED ON THE SHAFT.**

CONVERTING LATE 1978-1979 OEM ELECTRONICS TO COMPU-FIRE IGNITION

Refer to Figure 2.

NOTE: THESE MODELS USE A MECHANICAL ADVANCE ASSEMBLY. THIS ASSEMBLY WILL BE USED WITH THE COMPU-FIRE TRIGGER WHEEL.

6. Turn the ignition switch to the "off" position.
7. Disconnect the ground (-) cable from the battery.
8. Remove the ignition side cover (10), gasket (11) & ignition module (12). Remove the timer plate (17). Remove hex head bolt (14) in the advance assembly (19) securing the trigger rotor (18). Remove the trigger rotor (18). **MAKE SURE THE ADVANCE ASSEMBLY (19) REMAINS FULLY SEATED ON THE SHAFT.**

CONVERTING 1980 AND LATER OEM ELECTRONICS TO COMPU-FIRE IGNITION

NOTE: 1980 AND LATER BIKES ARE NOT EQUIPPED WITH A MECHANICAL ADVANCE ASSEMBLY. IN ORDER TO USE THE COMPU-FIRE MECHANICAL ADVANCE IGNITION, HARLEY-DAVIDSON® P/N 325 17-70 WILL BE REQUIRED.

Refer to Figure 3.

9. Drill out the rivets (20) in the outer cover (21) with a 3/8" drill bit and remove the outer cover.
10. Remove the inner cover (22) and gasket (23).
11. Remove the two standoffs (24). Disconnect the sensor wire connector from the ignition module. Push the terminals out through the back of the connector housing. This allows the terminals to pass through the hole in the ignition housing when the sensor plate is removed.
12. Remove the sensor plate (26).
13. Remove the bolt (27) securing the rotor (28).
14. Remove the rotor (28).
15. Fit the new mechanical advance mechanism (HD P/N 32517-70) to the camshaft being sure that the indexing pin on the bottom of the advance mechanism engages the slot on the end of the cam (Figure 4). **MAKE SURE THE ADVANCE ASSEMBLY REMAINS FULLY SEATED ON THE SHAFT. DO NOT INSTALL THE ADVANCE ASSEMBLY BOLT (27) AT THIS TIME.**

STEP #2: INSTALL THE COMPU-FIRE IGNITION COMPONENTS

NOTE: DO NOT use washers Figure 1 (5). Figure 2 (16) or Figure 3 (25).

16. Refer to FIGURE 5. Install the electronic ignition plate assembly (35). Thread me wire through the hole in the housing as you install the assembly. Locate me plate so that the holes for the standoff screws (32) that secure it fall in the middle of the adjustment slots and the V notch in the plate assembly is over the V grooved area in the housing (Figure 6). This groove is at either the 7 o'clock or 11 o'clock position.
17. Install the two standoff screws (32) just tight enough so the plate assembly can be rotated to set timing.

18. BE SURE the advance mechanism (36) is straight on the shaft and mount the trigger rotor (34) to the advance mechanism (36). NOTE: THE ROTOR FITS ON THE ADVANCE MECHANISM IN TWO WAYS, 180 DEGREES APART. ONLY ONE WAY IS RIGHT! ALIGN THE FLAT SURFACE ON THE BOTTOM OF THE ROTOR SHAFT WITH THE ROLL PIN INSTALLED IN THE ADVANCE ASSEMBLY PLATE. The rotor is installed properly when the top of the rotor is located just below the end of the advance mechanism shaft. Secure the trigger rotor and advance mechanism with the supplied bolt, using Blue Loctite® to prevent loosening. Torque bolt to 25 in.-lbs. Rotate the trigger rotor counterclockwise by hand to insure the advance mechanism is working freely. When released, the rotor should snap back to its original position.
19. Remove the point wire or module wires from the coil. Pull the wires from the COMPU-FIRE ignition plate through the hole in the housing. Be sure the wires do not interfere with the trigger rotor. Route the wires through the cable clamp next to the housing. Leave cable clamp loose until timing adjustment is complete.

STEP #3: SET THE IGNITION TIMING

AT THIS POINT THE TIMING IS SET USING THE BUILT-IN ACCU-RAY TIMING LIGHT. This procedure greatly simplifies the timing of the ignition system and is much simpler than it sounds. Read steps 20 through 28 completely before beginning.

20. MAKE SURE the ignition switch is off. RECONNECT BATTERY GROUND CABLE.
21. Remove the plug from the timing mark observation hole.
22. With the transmission in top gear move the bike until the front cylinder advance mark is in the center of the hole, see Figure 11.
23. Rotate the COMPU-FIRE rotor to its maximum counterclockwise (advance position and observe its position with respect to the ignition plate. Refer to Figure 12. It will be close to one of the two positions shown in Figure 12a or 12b. It should be close to the position shown in Figure 12a. If not, push the bike to rotate the flywheel one more revolution.
24. The RED wire must now be connected directly to the positive (+) battery terminal. BE CAREFUL NOT TO SHORT THE BATTERY TO GROUND, Carefully slit the harness jacket about one inch to expose the inner wires. Remove the excess jacket. Strip the red wire and connect it to the positive (+) battery terminal. DO NOT strip any of the other wires.
25. The ACCU-RAY timing light may be on or off. Use the large disk magnet supplied in the hardware kit to turn this light on and off to get familiar with it. Place the magnet against the rotor in the area shown in Figure 13. When the side of the magnet with orange dot is facing you the light will turn on. Turning the magnet over will turn the light off.
26. The plate needs to be adjusted to the point that the ACCU-RAY timing light just turns on when the rotor is rotated to its maximum counterclockwise (advance) position. If the light comes on before reaching this point, rotate the plate slightly counterclockwise. If the rotor can be rotated to its maximum counterclockwise position and the light does not come on, rotate the plate slightly clockwise.
27. Repeat the process until the ACCU-RAY timing light just turns on when the rotor reaches its maximum position. Use the disk magnet to turn the light off between adjustments when necessary. (See Figure 13).
28. The ignition system is now timed.
29. Tighten the standoffs.

30. Reinstall the observation hole plug and the ignition side covers) and tighten the cable clamp.
31. Disconnect the red wire from the battery.
32. Route the cable to the coil(s) making sure it does not touch hot surfaces. Cut the harness to length.
33. Carefully slit the harness jacket to expose the inner wires. Remove the excess jacket.

STEP #4: CONNECT WIRES TO THE COIL(S)

CAUTION!! CONNECTING THE WIRES INCORRECTLY CAN DAMAGE THE ELECTRONICS MODULE.

COMPU-FIRE Ignition Systems may be used with any high quality coil with 2 to 3 ohms of primary resistance. For the maximum possible energy output, COMPU-FIRE Coils P/N 30640 for single fire or P/N 30650 for dual fire applications offer 50,000 Volt output.

Dual Fire. Single Plug. P/N 20100

Refer to Figure 7.

RED wire: Positive (+) coil primary terminal. This is the terminal that has the wire already on it from the ignition switch.

BLACK wire: Negative (-) coil primary terminal. This is the terminal that had the wire already on it from the breaker points or stock ignition module.

Single Fire. Single Plug. P/N 20200

Refer to Figure 8.

RED wire: Positive (+) coil primary terminals. These are the two primary coil terminals that will be wired together and will have a wire on them from the ignition switch. Some dual coil packs have only a single terminal for the positive coil primaries. Both coils are connected to this terminal internally.

BLACK wire: Negative (-) primary terminal on the coil for the FRONT cylinder. This terminal had the wire on it that went to the breaker points or stock ignition module.

WHITE wire: Negative (-) primary terminal on the coil for the REAR cylinder.

For Single fire Dual Plug

Refer to Figure 9.

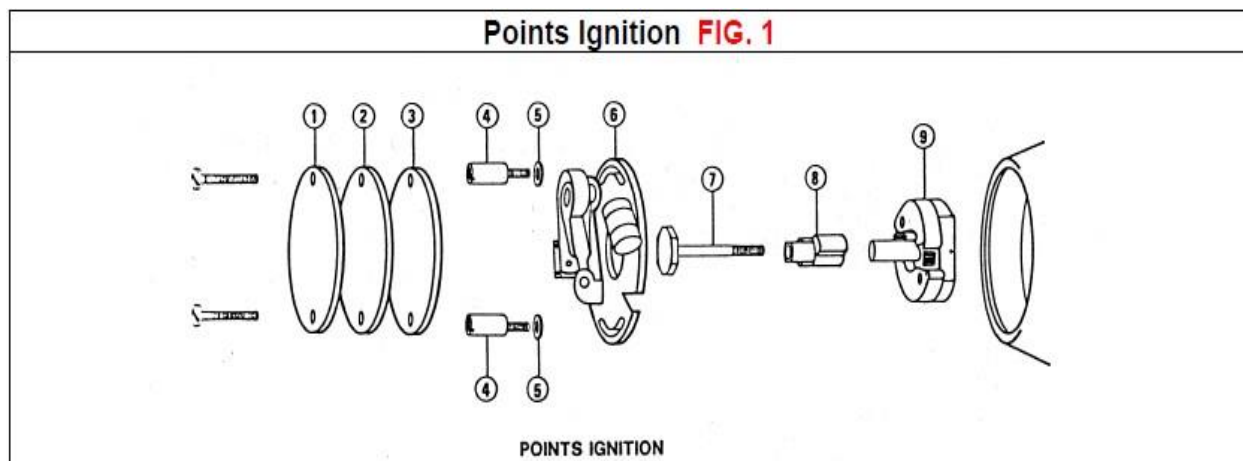

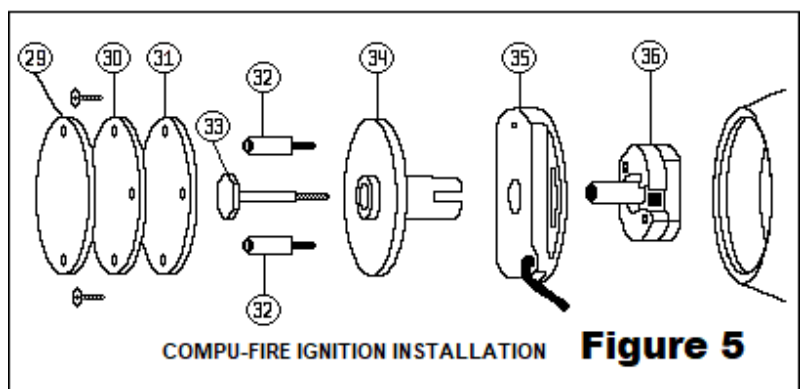
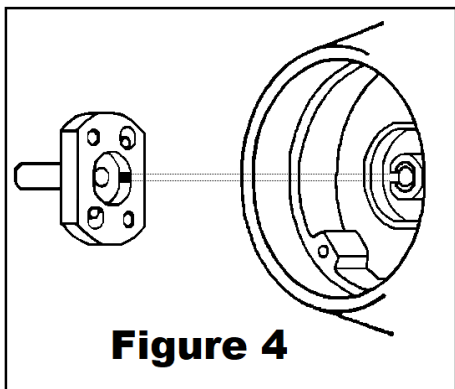
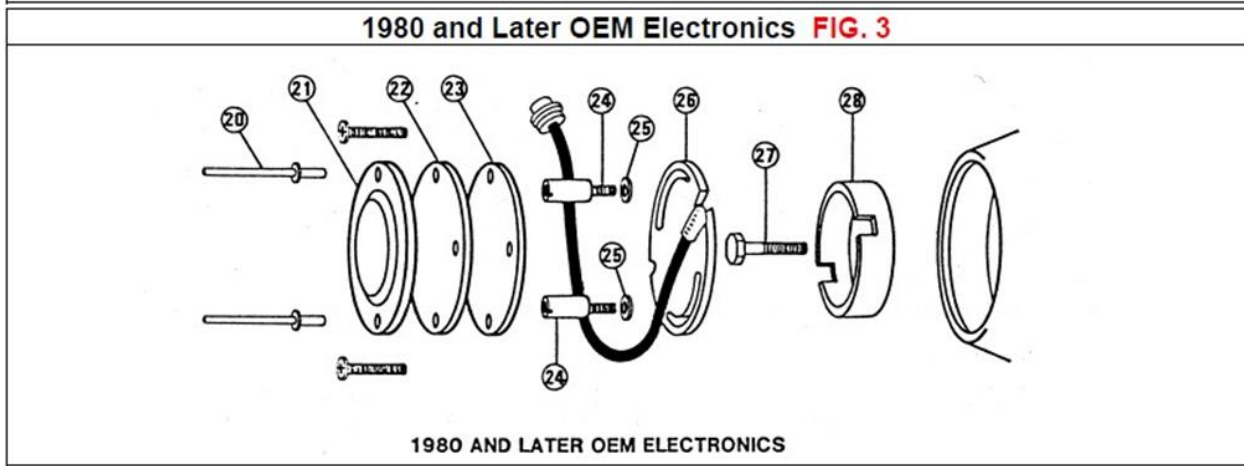
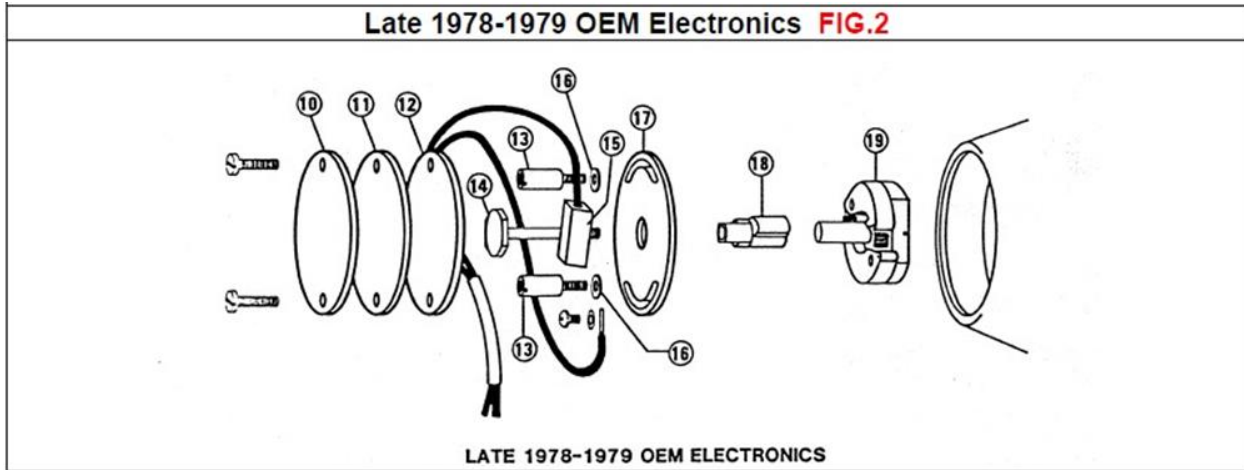

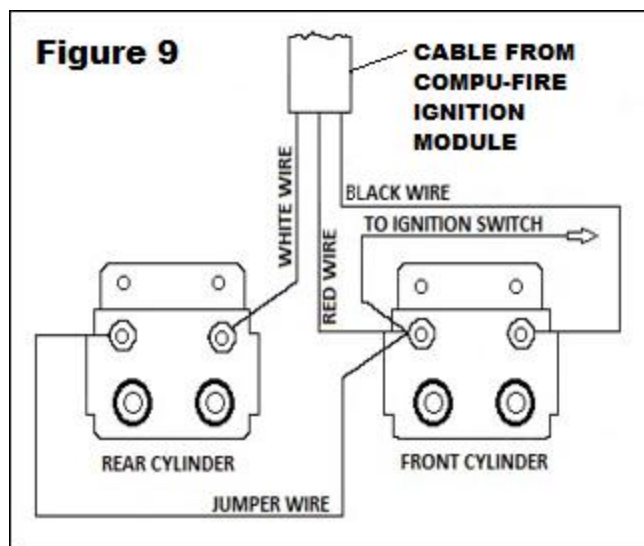
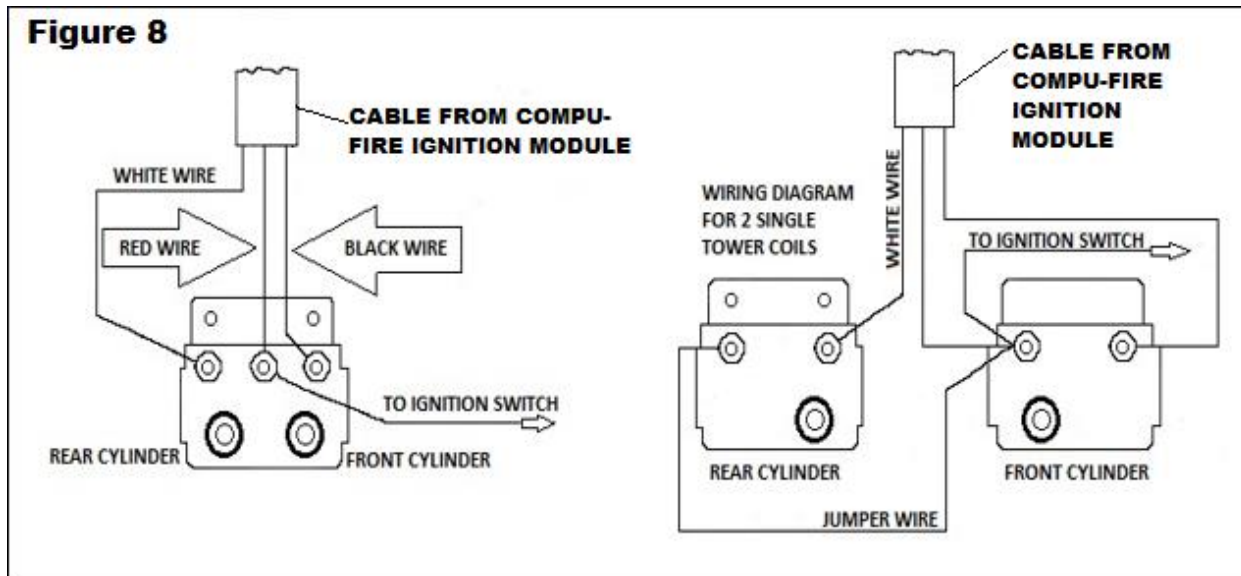
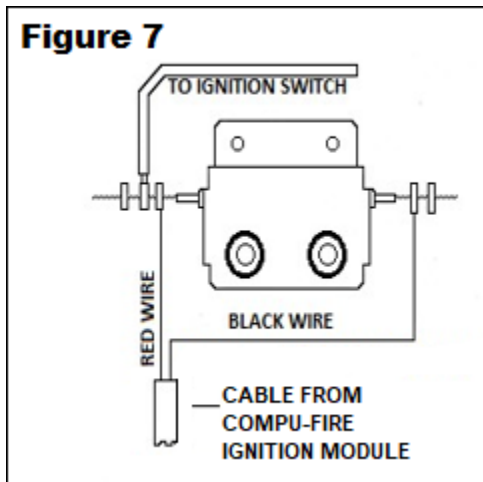
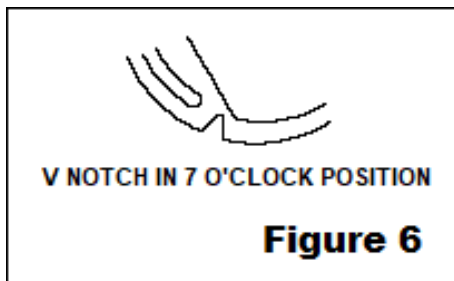

For technical assistance call 909/547-9058

**PerTronix, LLC.
440 E. Arrow Hwy.
San Dimas, CA 91773**



LIMITED WARRANTY

PerTronix, LLC. Warrants to the original Purchaser of its solid-state ignition system (product) that the module, trigger rotor and wiring (components) shall be free from defects in material and workmanship for a period of (12) months from the date of purchase.

If within the period of the foregoing warranty PerTronix finds, after inspection, that the product or any component thereof is defective, PerTronix will, at its option, repair such products or component or replace them with identical or similar parts PROVIDED that within such period Purchaser Promptly Notifies PerTronix, in writing, of such defects.