

# Dell EMC PowerEdge R940xa

## Installation and Service Manual

## Notes, cautions, and warnings

 **NOTE:** A NOTE indicates important information that helps you make better use of your product.

 **CAUTION:** A CAUTION indicates either potential damage to hardware or loss of data and tells you how to avoid the problem.

 **WARNING:** A WARNING indicates a potential for property damage, personal injury, or death.

<b>Chapter 1: About this document</b> .....	<b>7</b>
<b>Chapter 2: PowerEdge R940xa system overview</b> .....	<b>8</b>
Front view of the system.....	8
Control panels.....	9
LCD panel.....	9
Back view of the system.....	11
Inside the system.....	12
Locating the information tag of your system.....	12
System information label.....	13
<b>Chapter 3: Initial system setup and configuration</b> .....	<b>19</b>
Setting up your system.....	19
iDRAC configuration.....	19
Options to set up iDRAC IP address.....	19
Log in to iDRAC.....	20
Options to install the operating system.....	20
Methods to download firmware and drivers.....	20
Downloading drivers and firmware.....	21
<b>Chapter 4: Installing and removing system components</b> .....	<b>22</b>
Safety instructions.....	22
Before working inside your system.....	23
After working inside your system.....	23
Recommended tools.....	23
Front bezel.....	23
Removing the optional front bezel.....	24
Installing the optional front bezel.....	24
Drives.....	25
Drives.....	25
Removing a drive blank.....	25
Installing the drive blank.....	26
Removing a drive carrier.....	27
Installing the drive carrier.....	28
Removing the drive from the drive carrier.....	29
Installing the drive into the drive carrier.....	29
System cover.....	30
Removing the system cover.....	30
Installing the system cover.....	31
Support bar.....	32
Removing the support bar.....	32
Installing the support bar.....	33
Cooling fans.....	34
Removing the cooling fan.....	34

Installing a cooling fan.....	35
Cooling fan assembly.....	36
Removing the cooling fan assembly.....	36
Installing the cooling fan assembly.....	37
Optional USB 3.0 module.....	38
Removing the USB 3.0 module.....	38
Installing the USB 3.0 module.....	39
Optional optical drive.....	40
Removing the optical drive.....	40
Installing the optical drive.....	42
Control panel.....	44
Removing the left control panel.....	44
Installing the left control panel.....	45
Removing the right control panel.....	46
Installing the right control panel.....	47
Air shroud.....	49
Air shroud A .....	50
GPU shroud.....	52
Air shroud B.....	54
Air shroud C.....	56
NVDIMM-N battery.....	58
Removing the NVDIMM-N battery.....	58
Installing the NVDIMM-N battery.....	59
Drive backplane.....	59
Removing the drive backplane .....	61
Installing the backplane.....	63
Cable routing.....	65
System memory.....	68
General memory module installation guidelines.....	70
NVDIMM-N memory module installation guidelines .....	70
PMem installation guidelines .....	74
Mode-specific guidelines.....	77
Removing a memory module.....	80
Installing the memory module.....	81
Processors and heat sinks.....	82
Removing a processor and heat sink module.....	82
Removing the processor from the processor and heat sink module.....	84
Installing the processor on the processor and heat sink module.....	86
Installing a processor and heat sink module.....	87
Expansion cards and expansion card risers.....	89
Expansion card installation guidelines.....	89
Removing the expansion card riser.....	104
Installing the expansion card riser.....	106
Removing the expansion card from the riser.....	108
Installing the expansion card in the riser.....	109
Removing the expansion card from the system board.....	110
Installing the expansion card on the system board.....	112
GPU card installation guidelines.....	113
Removing the GPU.....	114
Installing the GPU.....	116

M.2 SSD module.....	118
Removing the M.2 BOSS module.....	118
Installing the M.2 BOSS module.....	119
Optional IDSDM or vFlash module.....	120
Removing the MicroSD card.....	120
Installing the MicroSD card.....	121
Removing the IDSDM or vFlash module.....	122
Installing the IDSDM or vFlash module.....	122
Network daughter card.....	123
Removing the network daughter card.....	123
Installing the network daughter card.....	124
System battery.....	125
Replacing the system battery.....	125
Optional internal USB memory key.....	126
Replacing the optional internal USB memory key.....	126
Power supply units.....	127
Hot spare feature.....	127
Removing a power supply unit blank.....	127
Installing the power supply unit blank.....	128
Removing a power supply unit.....	128
Installing the power supply unit.....	129
Wiring instructions for a DC power supply unit.....	130
Power interposer board.....	131
Removing the power interposer board.....	131
Installing the power interposer board.....	132
Trusted Platform Module.....	133
Upgrading the Trusted Platform Module.....	133
Initializing TPM for BitLocker users.....	134
Initializing the TPM 1.2 for TXT users.....	135
Initializing the TPM 2.0 for TXT users.....	135
System board.....	135
Removing the System Board.....	135
Installing the system board.....	137
Restore the service tag using Easy Restore.....	138
<b>Chapter 5: Jumpers and connectors .....</b>	<b>140</b>
System board connectors.....	141
System board jumper settings.....	143
Disabling a forgotten password.....	143
<b>Chapter 6: System diagnostics and indicator codes .....</b>	<b>145</b>
Status LED indicators.....	145
System health and system ID indicator codes.....	146
iDRAC Quick Sync 2 indicator codes.....	146
iDRAC Direct LED indicator codes.....	147
NIC indicator codes.....	147
Power supply unit indicator codes.....	148
Drive indicator codes.....	149
System diagnostics.....	150

Dell Embedded System Diagnostics.....	150
<b>Chapter 7: Getting help.....</b>	<b>151</b>
Contacting Dell.....	151
Documentation feedback.....	151
Accessing system information by using QRL.....	151
Quick Resource Locator for PowerEdge R940xa system.....	152
Receiving automated support with SupportAssist .....	152
Recycling or End-of-Life service information.....	153
<b>Chapter 8: Documentation resources.....</b>	<b>154</b>

# About this document

This document provides an overview about the system, information on installing and replacing components, technical specifications, diagnostic tools, and guidelines to be followed while installing certain components.

## PowerEdge R940xa system overview

The PowerEdge R940xa is a 4U rack server that supports up to:

- Four Intel Xeon Processor Scalable family processors
- 48 DIMM slots
- Four AC or DC power supply units with 2+2 redundancy, auto sensing, and autoswitching capability.
- 2.5-inch x 32 (SAS/SATA HDD/SSDs and that includes 4 NVMe SSDs).

For more information, see the Dell EMC PowerEdge R940xa Technical Specifications on the product documentation page.

**NOTE:** All instances of SAS, SATA hard drives, NVMe, and SSDs are referred to as drives in this document, unless specified otherwise.

### Topics:

- [Front view of the system](#)
- [Back view of the system](#)
- [Inside the system](#)
- [Locating the information tag of your system](#)
- [System information label](#)

## Front view of the system

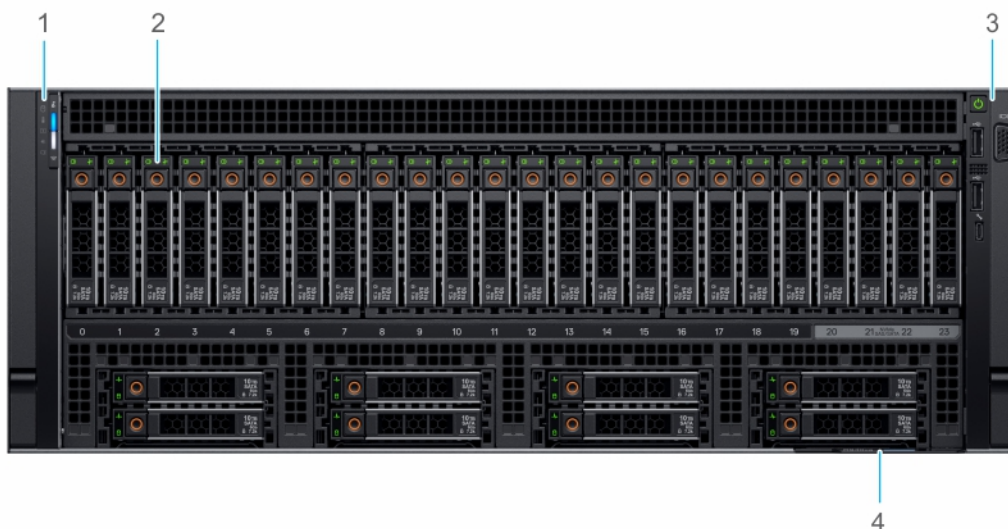

**Figure 1. Front view of 32 x 2.5-inch drive system**

- |                        |                    |
|------------------------|--------------------|
| 1. Left control panel  | 2. Drives (32)     |
| 3. Right control panel | 4. Information tag |



# Control panels

## Left control panel view

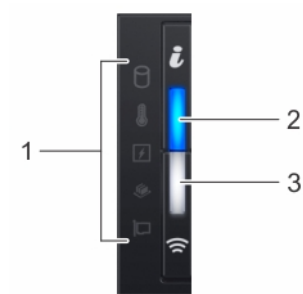

Figure 2. Left control panel view

1. Status LED indicators
2. System health and system ID indicator
3. iDRAC Quick Sync 2 wireless indicator (optional)

## Right control panel view

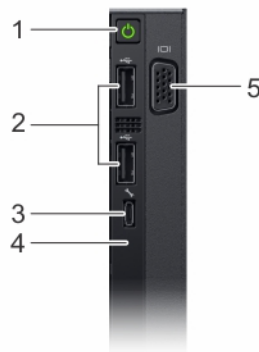

Figure 3. Right control panel view

1. Power button
2. USB 2.0 port (2)
3. iDRAC Direct port
4. iDRAC Direct LED
5. VGA port

**NOTE:** For more information, see the Dell EMC PowerEdge R940xa Technical Specifications on the product documentation page.

## LCD panel

The LCD panel provides system information, status, and error messages to indicate if the system is functioning correctly or requires attention. The LCD panel can also be used to configure or view the system's iDRAC IP address. For information about the event and error messages generated by the system firmware and agents that monitor system components, go to [qrl.dell.com](http://qrl.dell.com) > **Look Up** > **Error Code**, type the error code, and then click **Look it up**.

The statuses and conditions of the LCD panel are outlined here:

- The LCD backlight is white during normal operating conditions.
- When the system needs attention, the LCD backlight turns amber, and displays an error code followed by descriptive text.

**NOTE:** If the system is connected to a power source and an error is detected, the LCD turns amber regardless of whether the system is turned on or off.

- When the system turns off and there are no errors, LCD enters the standby mode after five minutes of inactivity. Press any button on the LCD to turn it on.
- If the LCD panel stops responding, remove the bezel and reinstall it. If the problem persists, see the PowerEdge T640 Technical Specs at [www.dell.com/poweredgemanuals](http://www.dell.com/poweredgemanuals)
- The LCD backlight remains off if LCD messaging is turned off using the iDRAC utility, the LCD panel, or other tools.

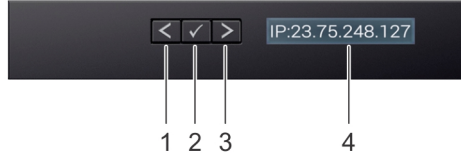

Figure 4. LCD panel features



Table 1. LCD panel features

Item	Button or display	Description
1	Left	Moves the cursor back in one-step increments.
2	Select	Selects the menu item highlighted by the cursor.
3	Right	Moves the cursor forward in one-step increments. During message scrolling: <ul style="list-style-type: none"> <li>• Press and hold the right button to increase scrolling speed.</li> <li>• Release the button to stop.</li> </ul> <b>NOTE:</b> The display stops scrolling when the button is released. After 45 seconds of inactivity, the display starts scrolling.
4	LCD display	Displays system information, status, and error messages or iDRAC IP address.

## Viewing Home screen

The **Home** screen displays user-configurable information about the system. This screen is displayed during normal system operation when there are no status messages or errors. When the system turns off and there are no errors, LCD enters the standby mode after five minutes of inactivity. Press any button on the LCD to turn it on.

### Steps

1. To view the **Home** screen, press one of the three navigation buttons (Select, Left, or Right).
2. To navigate to the **Home** screen from another menu, complete the following steps:
  - a. Press and hold the navigation button till the up arrow  is displayed.
  - b. Navigate to the  using the up arrow .
  - c. Select the **Home** icon.
  - d. On the **Home** screen, press the **Select** button to enter the main menu.

## Setup menu

**NOTE:** When you select an option in the **Setup** menu, you must confirm the option before proceeding to the next action.

Option	Description
iDRAC	Select <b>DHCP</b> or <b>Static IP</b> to configure the network mode. If <b>Static IP</b> is selected, the available fields are <b>IP</b> , <b>Subnet (Sub)</b> , and <b>Gateway (Gtw)</b> . Select <b>Setup DNS</b> to enable DNS and to view domain addresses. Two separate DNS entries are available.

Option	Description
<b>Set error</b>	Select <b>SEL</b> to view LCD error messages in a format that matches the IPMI description in the SEL. This enables you to match an LCD message with an SEL entry.  Select <b>Simple</b> to view LCD error messages in a simplified user-friendly description. For information about the event and error messages generated by the system firmware and agents that monitor system components, go to <a href="http://qrl.dell.com">qrl.dell.com</a> > <b>Look Up</b> > <b>Error Code</b> , type the error code, and then click <b>Look it up</b> .
<b>Set home</b>	Select the default information to be displayed on the <b>Home</b> screen. See View menu section for the options and option items that can be set as the default on the <b>Home</b> screen.

## View menu

**NOTE:** When you select an option in the **View** menu, you must confirm the option before proceeding to the next action.

Option	Description
<b>iDRAC IP</b>	Displays the <b>IPv4</b> or <b>IPv6</b> addresses for iDRAC9. Addresses include <b>DNS (Primary and Secondary)</b> , <b>Gateway, IP</b> , and <b>Subnet</b> (IPv6 does not have Subnet).
<b>MAC</b>	Displays the MAC addresses for <b>iDRAC</b> , <b>iSCSI</b> , or <b>Network</b> devices.
<b>Name</b>	Displays the name of the <b>Host</b> , <b>Model</b> , or <b>User String</b> for the system.
<b>Number</b>	Displays the <b>Asset tag</b> or the <b>Service tag</b> for the system.
<b>Power</b>	Displays the power output of the system in BTU/hr or Watts. The display format can be configured in the <b>Set home</b> submenu of the <b>Setup</b> menu.
<b>Temperature</b>	Displays the temperature of the system in Celsius or Fahrenheit. The display format can be configured in the <b>Set home</b> submenu of the <b>Setup</b> menu.

## Back view of the system

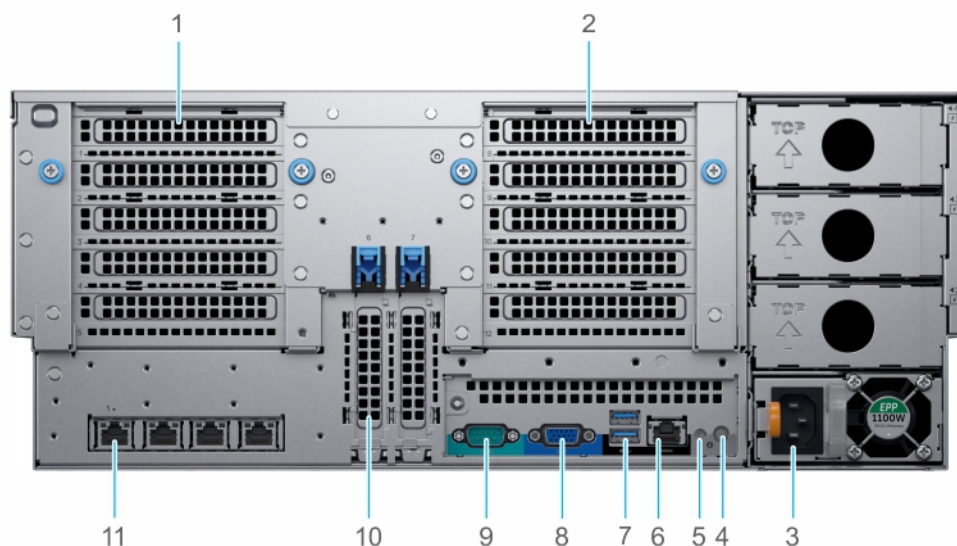

**Figure 5. Back view of the system**

- |   |  |
|---|--|
| 1. Full-height expansion riser 1            | 2. Full-height expansion riser 2         |
| 3. Power supply units (4)                   | 4. System identification button          |
| 5. System status indicator cable port (CMA) | 6. iDRAC9 dedicated port                 |
| 7. USB 3.0 ports (2)                        | 8. VGA port                              |
| 9. Serial port                              | 10. Low profile expansion card slots (2) |

## 11. NIC ports (4)

For more information, see the Dell EMC PowerEdge R940xa Technical Specifications on the product documentation page.

**NOTE:** The expansion card configurations are X8 PCIe Riser 1+X8 PCIe Riser 2 or X16 PCIe Riser 1+X16 PCIe Riser 2.

## Inside the system

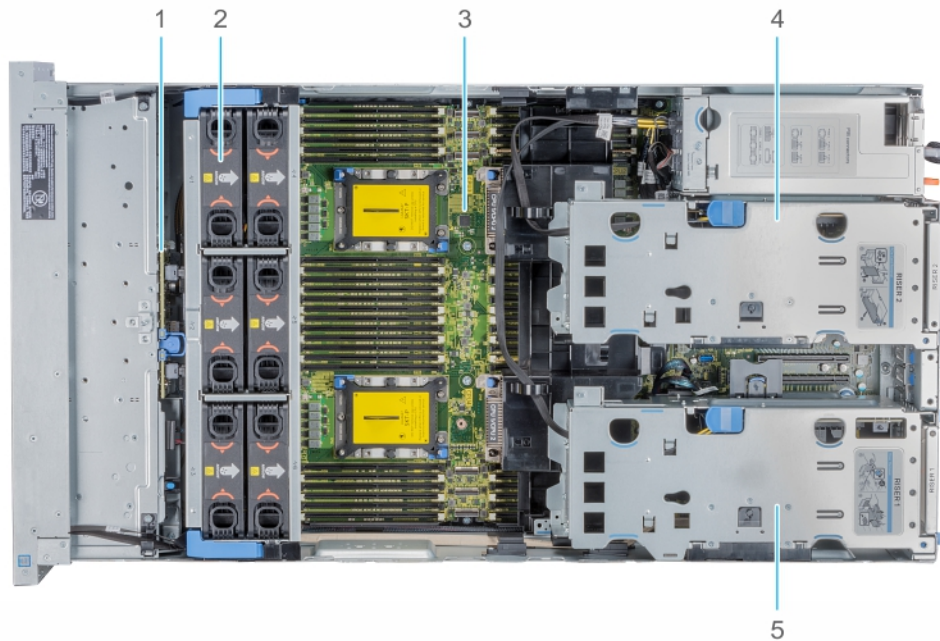

**Figure 6. Inside the system**

1. Drive backplane
2. Cooling fan assembly
3. System board
4. Riser 2
5. Riser 1

## Locating the information tag of your system

You can identify your system using the unique Express Service Code and Service Tag. Pull out the information tag in front of the system to view the Express Service Code and Service Tag. Alternatively, the information may be on a sticker on the back of the system chassis. The mini Enterprise Service Tag (EST) is found on the back of the system chassis. This information is used by Dell to route support calls to the appropriate personnel.

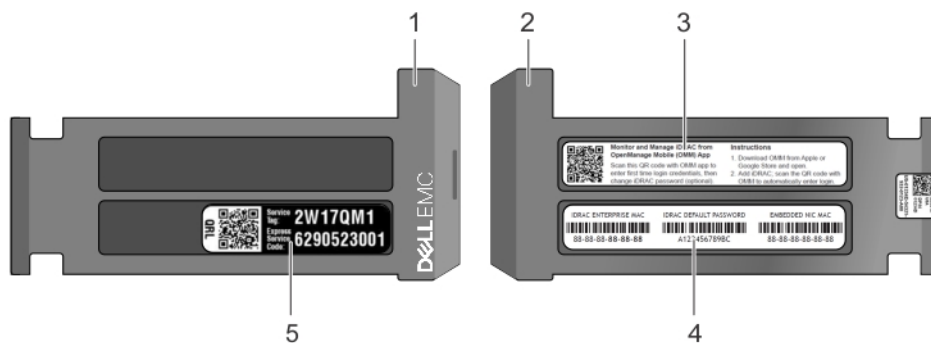

Figure 7. Locating the information tag of your system

1. Information tag (Top view)
2. Information tag (Bottom view)
3. OpenManage Mobile (OMM) label
4. iDRAC MAC address and iDRAC secure password label

**NOTE:** If you have opted for secure default access to iDRAC, the iDRAC secure default password is available on the back of the system Information tag. This label will be blank, if you have not opted for secure default access to iDRAC, then the default user name and password are **root** and **calvin**.

5. Service Tag

## System information label

### PowerEdge R940xa – Front system information label

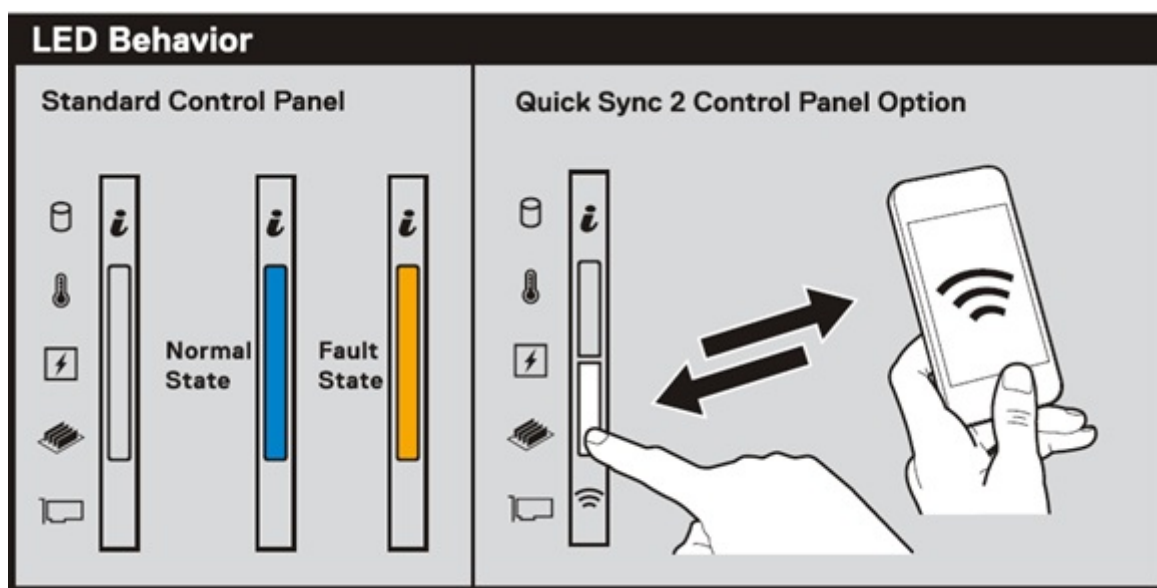

Figure 8. LED behavior

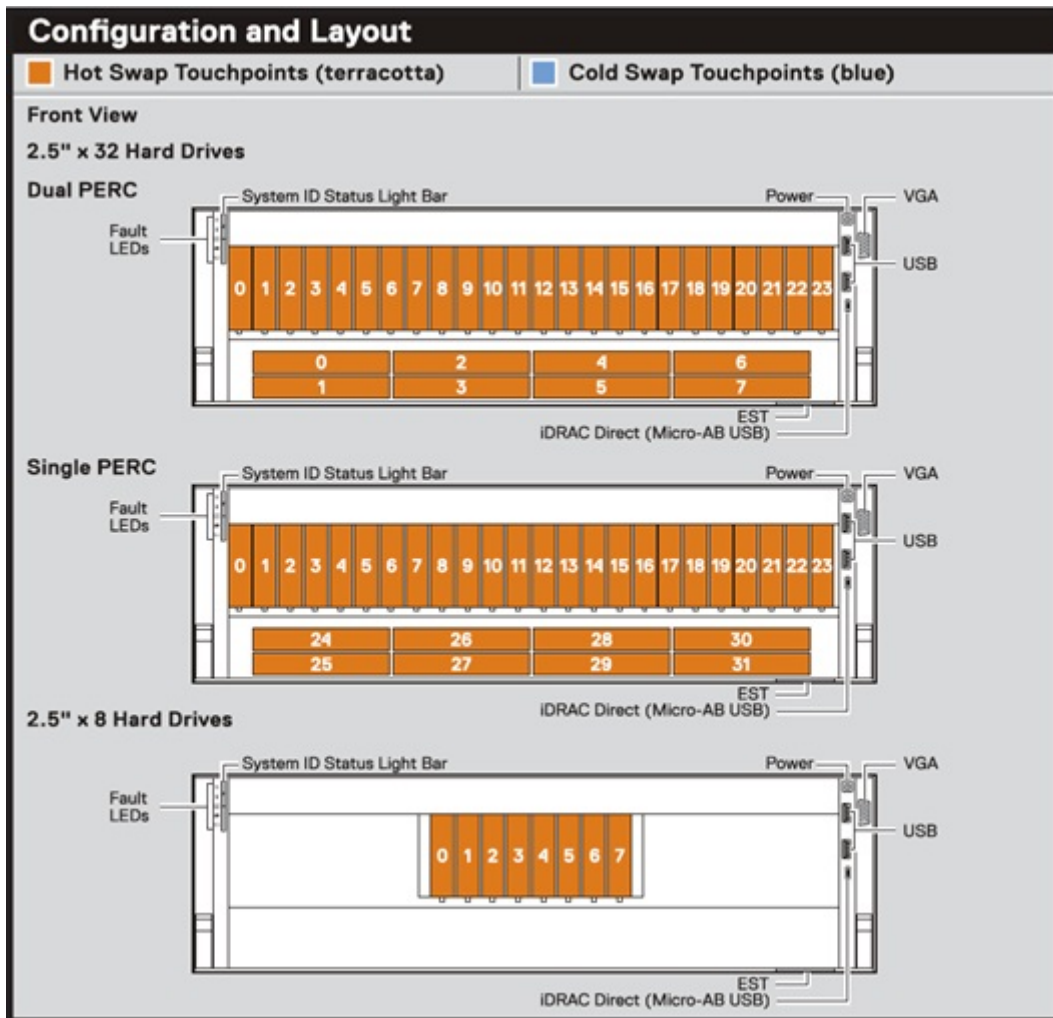

Figure 9. Configuration and layout

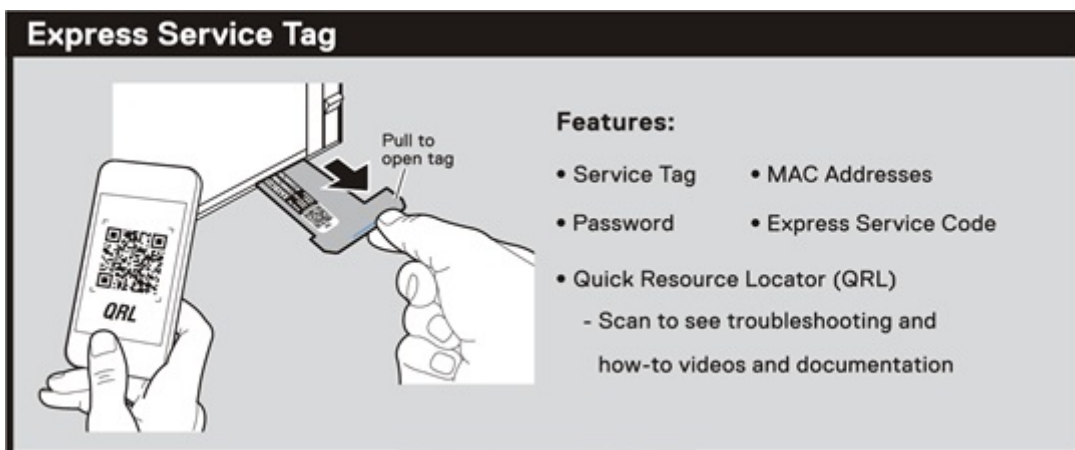

Figure 10. Express service tag

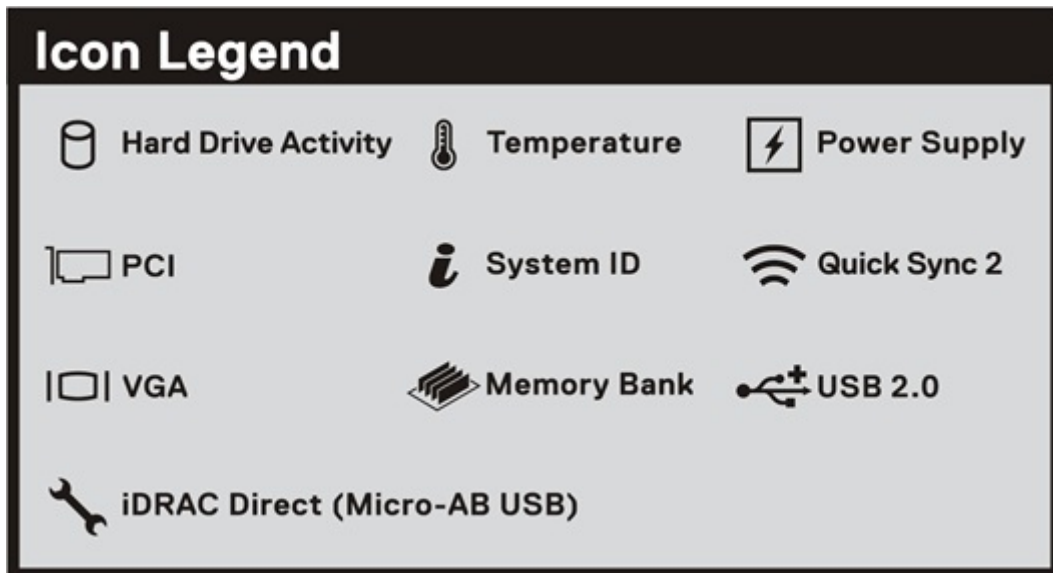

Figure 11. Icon Legend

## PowerEdge R940xa – Service information

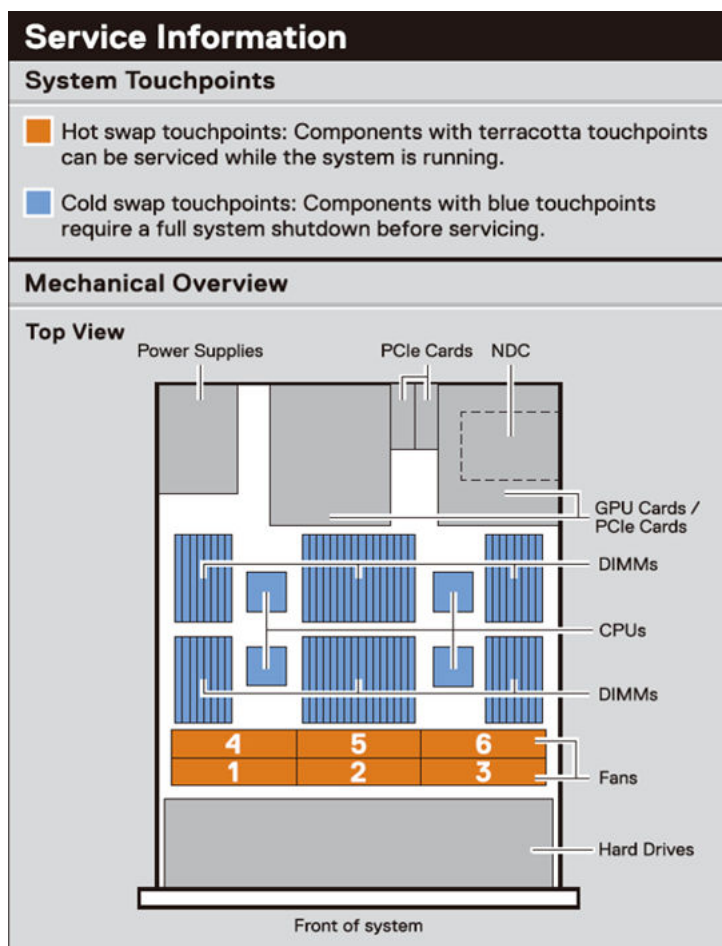

Figure 12. Service Information

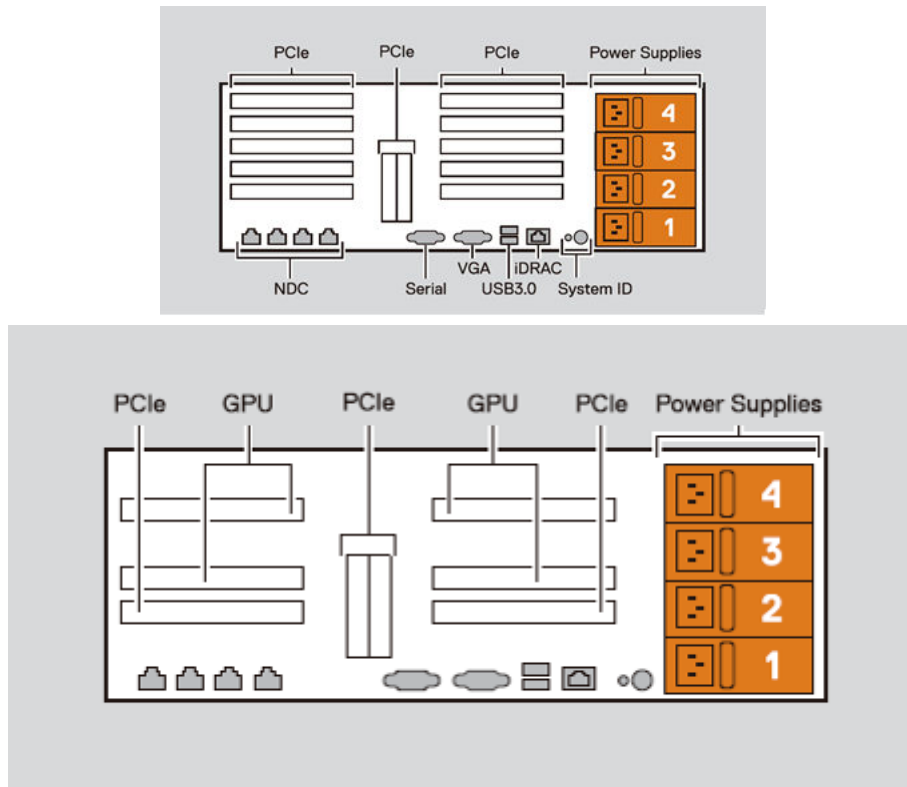

Figure 13. Rear view configuration





Jumper Settings		
Jumper	Setting	Description
PWRD_EN	 (default)	BIOS password is enabled.
		BIOS password is disabled. iDRAC local access unlocked at next AC power cycle. iDRAC password reset is enabled in F2 iDRAC setting menu.
	 (default)	BIOS configuration settings retained at system boot.
NVRAM_CLR		BIOS configuration settings cleared at system boot.

Figure 14. Jumper settings



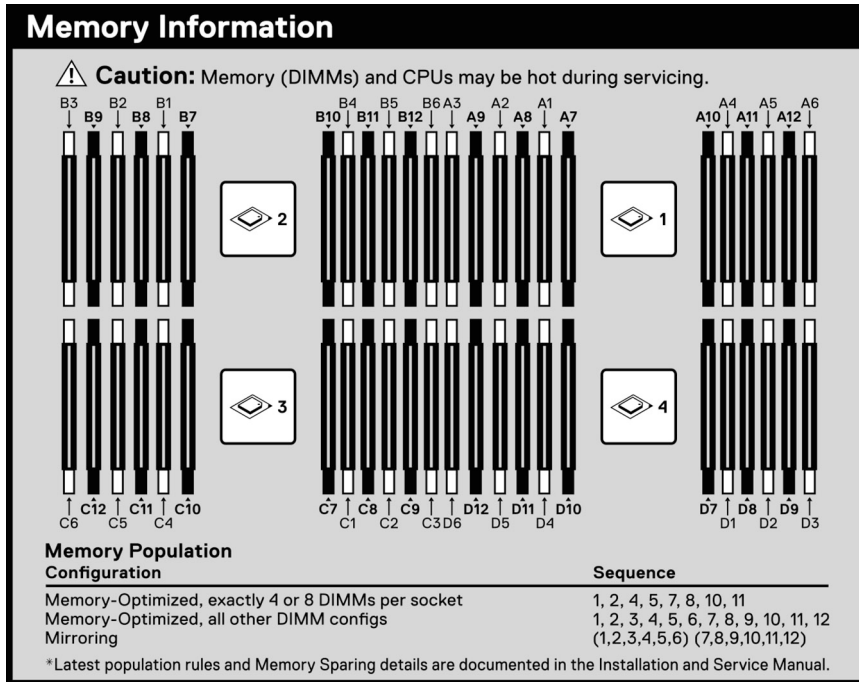

Figure 15. Memory information

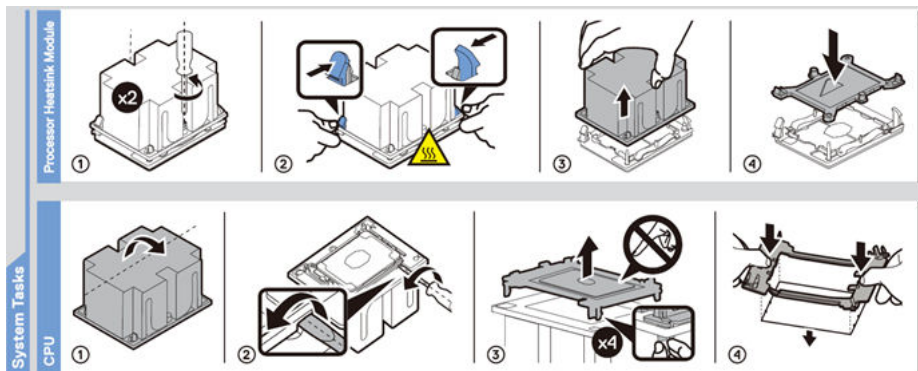

Figure 16. System tasks

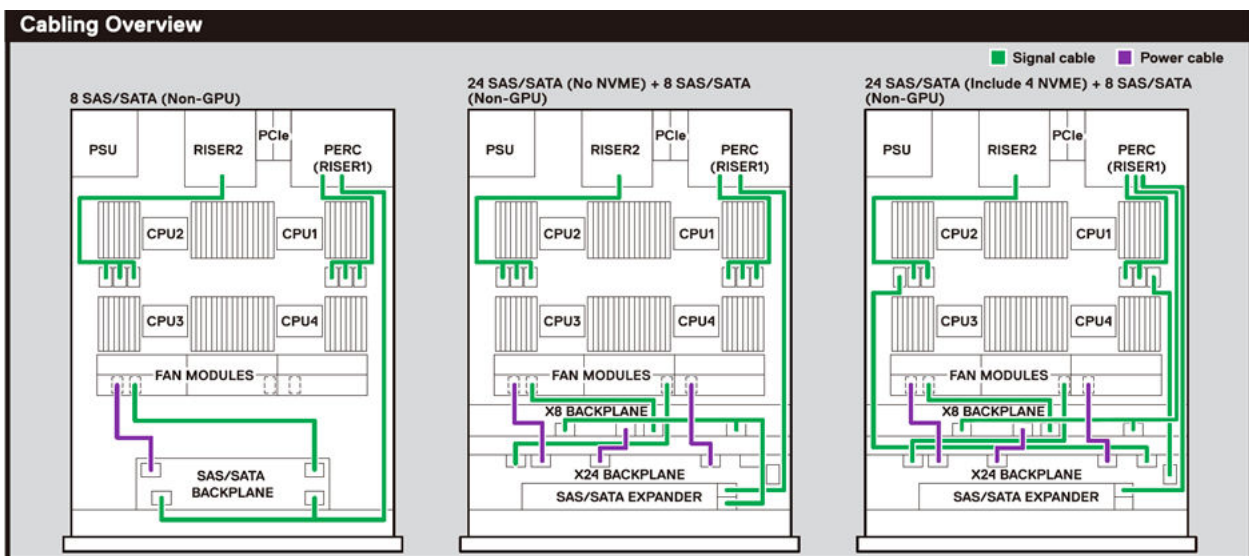

Figure 17. Cabling overview

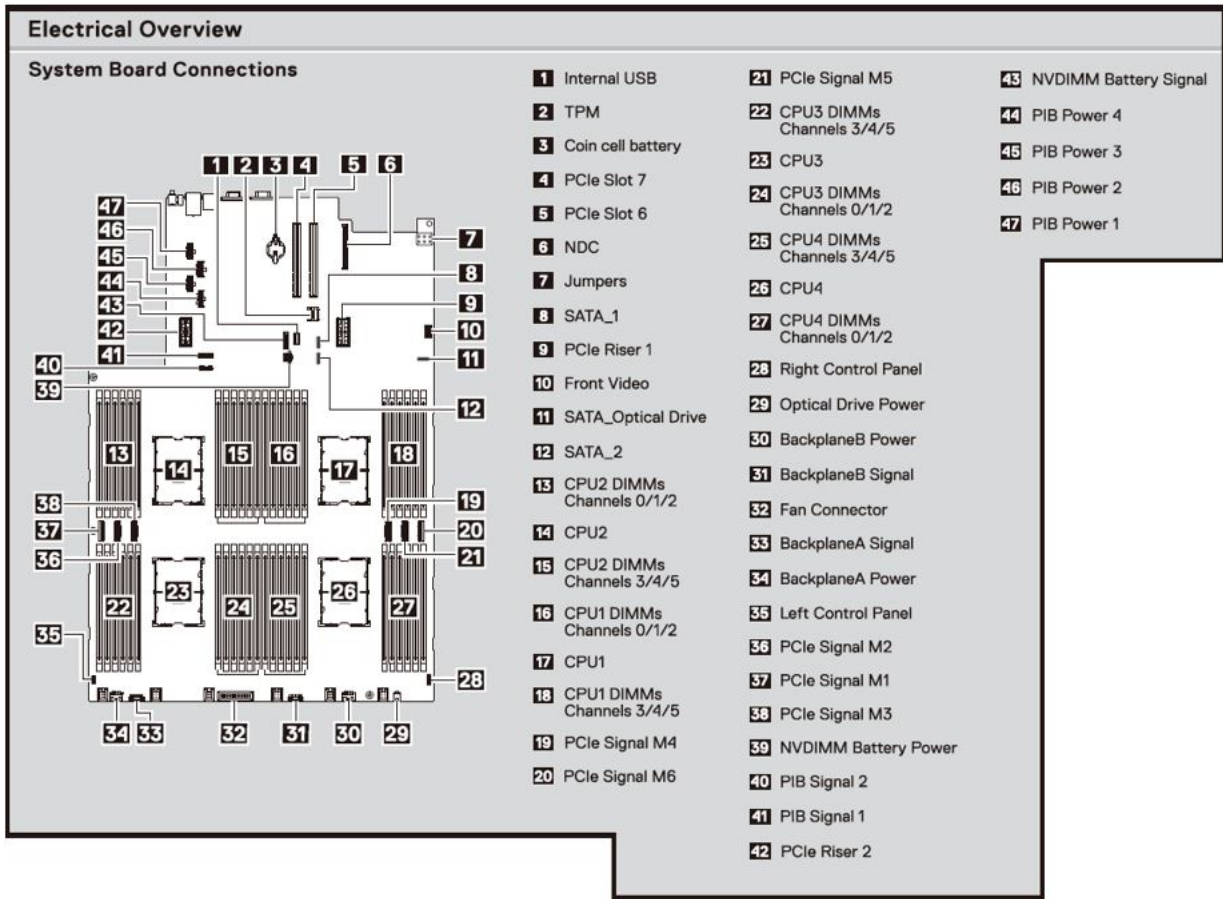

Figure 18. Electrical overview

# Initial system setup and configuration

## Topics:

- [Setting up your system](#)
- [iDRAC configuration](#)
- [Options to install the operating system](#)

## Setting up your system

Perform the following steps to set up your system:

### Steps

1. Unpack the system.
2. Install the system into the rack. For more information about installing the system into the rack, see the *Rail Installation Guide* at [www.dell.com/poweredgemanuals](http://www.dell.com/poweredgemanuals).
3. Connect the peripherals to the system.
4. Connect the system to its electrical outlet.
5. Power on the system by pressing the power button or by using iDRAC.
6. Power on the attached peripherals.

For more information about setting up your system, see the *Getting Started Guide* that shipped with your system.

For information on how to manage basic settings and features of the system, see the Dell EMC PowerEdge R940xa BIOS and UEFI Reference Guide on the product documentation page.

## iDRAC configuration

The Integrated Dell Remote Access Controller (iDRAC) is designed to make system administrators more productive and improve the overall availability of Dell systems. iDRAC alerts administrators about system issues and enables them to perform remote system management. This reduces the need for physical access to the system.

## Options to set up iDRAC IP address

To enable communication between your system and iDRAC, you must first configure the network settings based on your network infrastructure.

 **NOTE:** For static IP configuration, you must request for it at the time of purchase.

This option is set to **DHCP** by Default. You can set up the IP address by using one of the following interfaces:

Interfaces	Document/Section
<b>iDRAC Settings utility</b>	<i>Dell Integrated Dell Remote Access Controller User's Guide</i> at <a href="http://www.dell.com/poweredgemanuals">www.dell.com/poweredgemanuals</a>
<b>Dell Deployment Toolkit</b>	<i>Dell Deployment Toolkit User's Guide</i> at <a href="http://www.dell.com/openmanagemanuals">www.dell.com/openmanagemanuals</a> > OpenManage Deployment Toolkit
<b>Dell Lifecycle Controller</b>	<i>Dell Lifecycle Controller User's Guide</i> at <a href="http://www.dell.com/poweredgemanuals">www.dell.com/poweredgemanuals</a>
<b>Server LCD panel</b>	<a href="#">LCD panel</a> section

## Interfaces Document/Section

**iDRAC Direct and Quick Sync 2 (optional)** See *Dell Integrated Dell Remote Access Controller User's Guide* at [www.dell.com/poweredge manuals](http://www.dell.com/poweredge manuals)

**NOTE:** To access iDRAC, ensure that you connect the ethernet cable to the iDRAC9 dedicated network port. You can also access iDRAC through the shared LOM mode, if you have opted for a system that has the shared LOM mode enabled.

## Log in to iDRAC

You can log in to iDRAC as:

- iDRAC user
- Microsoft Active Directory user
- Lightweight Directory Access Protocol (LDAP) user

If you have opted for secure default access to iDRAC, you must use the iDRAC secure default password available on the system Information tag. If you have not opted for secure default access to iDRAC, then use the default user name and password `-root` and `calvin`. You can also log in by using your Single Sign-On or Smart Card.

**NOTE:** You must have the iDRAC credentials to log in to iDRAC.

**NOTE:** Ensure that you change the default username and password after setting up the iDRAC IP address.

For more information about logging in to the iDRAC and iDRAC licenses, see the latest *Integrated Dell Remote Access Controller User's Guide* at [www.dell.com/poweredge manuals](http://www.dell.com/poweredge manuals).

You can also access iDRAC by using RACADM. For more information, see the *RACADM Command Line Interface Reference Guide* at [www.dell.com/poweredge manuals](http://www.dell.com/poweredge manuals).

## Options to install the operating system

If the system is shipped without an operating system, install a supported operating system by using one of the following resources:

**Table 2. Resources to install the operating system**

Resources	Location
iDRAC	<a href="http://www.dell.com/idrac manuals">www.dell.com/idrac manuals</a>
Lifecycle Controller	<a href="http://www.dell.com/idrac manuals">www.dell.com/idrac manuals</a> > Lifecycle Controller
OpenManage Deployment Toolkit	<a href="http://www.dell.com/openmanage manuals">www.dell.com/openmanage manuals</a> > OpenManage Deployment Toolkit
Dell certified VMware ESXi	<a href="http://www.dell.com/virtualizationsolutions">www.dell.com/virtualizationsolutions</a>
Installation and How-to videos for supported operating systems on PowerEdge systems	<a href="#">Supported Operating Systems for Dell EMC PowerEdge systems</a>

## Methods to download firmware and drivers

You can download the firmware and drivers by using any of the following methods:

**Table 3. Firmware and drivers**

Methods	Location
From the Dell EMC support site	<a href="http://www.dell.com/support/home">www.dell.com/support/home</a>
Using Dell Remote Access Controller Lifecycle Controller (iDRAC with LC)	<a href="http://www.dell.com/idrac manuals">www.dell.com/idrac manuals</a>

**Table 3. Firmware and drivers (continued)**

Methods	Location
Using Dell Repository Manager (DRM)	<a href="http://www.dell.com/openmanagemanuals">www.dell.com/openmanagemanuals</a> > Repository Manager
Using Dell OpenManage Essentials	<a href="http://www.dell.com/openmanagemanuals">www.dell.com/openmanagemanuals</a> > OpenManage Essentials
Using Dell OpenManage Enterprise	<a href="http://www.dell.com/openmanagemanuals">www.dell.com/openmanagemanuals</a> > OpenManage Enterprise
Using Dell Server Update Utility (SUU)	<a href="http://www.dell.com/openmanagemanuals">www.dell.com/openmanagemanuals</a> > Server Update Utility
Using Dell OpenManage Deployment Toolkit (DTK)	<a href="http://www.dell.com/openmanagemanuals">www.dell.com/openmanagemanuals</a> > OpenManage Deployment Toolkit
Using iDRAC virtual media	<a href="http://www.dell.com/idracmanuals">www.dell.com/idracmanuals</a>

## Downloading drivers and firmware

Dell EMC recommends that you download and install the latest BIOS, drivers, and systems management firmware on your system.

### Prerequisites

Ensure that you clear the web browser cache before downloading the drivers and firmware.

### Steps

1. Go to [www.dell.com/support/home](http://www.dell.com/support/home).
2. In the **Drivers & Downloads** section, type the Service Tag of your system in the **Enter a Service Tag or product ID** box, and then click **Submit**.  
 **NOTE:** If you do not have the Service Tag, select **Detect Product** to allow the system to automatically detect the Service Tag, or click **View products**, and navigate to your product.
3. Click **Drivers & Downloads**.  
The drivers that are applicable to your system are displayed.
4. Download the drivers to a USB drive, CD, or DVD.

# Installing and removing system components

**CAUTION:** Many repairs may only be done by a certified service technician. You should only perform troubleshooting and simple repairs as authorized in your product documentation, or as directed by the online or telephone service and support team. Damage due to servicing that is not authorized by Dell is not covered by your warranty. Read and follow the safety instructions that are shipped with your product.

## Topics:

- Safety instructions
- Before working inside your system
- After working inside your system
- Recommended tools
- Front bezel
- Drives
- System cover
- Support bar
- Cooling fans
- Cooling fan assembly
- Optional USB 3.0 module
- Optional optical drive
- Control panel
- Air shroud
- NVDIMM-N battery
- Drive backplane
- System memory
- Processors and heat sinks
- Expansion cards and expansion card risers
- M.2 SSD module
- Optional IDSDM or vFlash module
- Network daughter card
- System battery
- Optional internal USB memory key
- Power supply units
- Power interposer board
- Trusted Platform Module
- System board

## Safety instructions

**NOTE:** Whenever you need to lift the system, get others to assist you. To avoid injury, do not attempt to lift the system by yourself.

**WARNING:** Opening or removing the system cover while the system is powered on may expose you to a risk of electric shock.

**CAUTION:** Do not operate the system without the cover for a duration exceeding five minutes. Operating the system without the system cover can result in component damage.

**CAUTION:** Many repairs may only be done by a certified service technician. You should only perform troubleshooting and simple repairs as authorized in your product documentation, or as directed by the online or

telephone service and support team. Damage due to servicing that is not authorized by Dell is not covered by your warranty. Read and follow the safety instructions that are shipped with your product.

**NOTE:** It is recommended that you always use an antistatic mat and antistatic strap while working on components inside the system.

**CAUTION:** To ensure proper operation and cooling, all bays in the system and system fans must be always populated with a component or a blank.

## Before working inside your system

### Prerequisites

Follow the safety guidelines listed in [Safety instructions](#).

### Steps

1. Turn off the system, including all attached peripherals.
2. Disconnect the system from the electrical outlet and disconnect the peripherals.
3. If applicable, remove the system from the rack.  
For more information, see the *Rail Installation Guide* at <https://www.dell.com/poweredgemanuals>.
4. [Remove the system cover](#).

## After working inside your system

### Prerequisites

Follow the safety guidelines listed in [Safety instructions](#).

### Steps

1. [Replace the system cover](#).
2. If applicable, install the system into the rack.  
For more information, see the *Rail Installation Guide* at <https://www.dell.com/poweredgemanuals>.
3. Reconnect the peripherals and connect the system to the electrical outlet.
4. Turn on the attached peripherals and then turn on the system.

## Recommended tools

You need the following tools to perform the removal and installation procedures:

- Key to the bezel lock  
The key is required only if your system includes a bezel.
- Phillips #1 screwdriver
- Phillips #2 screwdriver
- Torx #T30 screwdriver
- Wrist grounding strap

## Front bezel

A lock on the bezel is used to protect unauthorized access to the drives. The system status can be viewed on the bezel with the LCD panel. For more information, see [LCD panel](#).

## Removing the optional front bezel

### Prerequisites

Follow the safety guidelines listed in [Safety instructions](#).

### Steps

1. Unlock the bezel by using the bezel key.
2. Press the release button, and pull the left end of the bezel.
3. Unhook the right end, and remove the bezel.



Figure 19. Removing the optional front bezel with the LCD panel

### Next steps

1. [Replace the front bezel.](#)

## Installing the optional front bezel

### Prerequisites

1. Follow the safety guidelines listed in [Safety instructions](#).
2. Locate and remove the bezel key.

**i** **NOTE:** The bezel key is part of the optional front bezel.

### Steps

1. Align and insert the right end of the bezel onto the system.
2. Press the release button and fit the left end of the bezel onto the system.
3. Lock the bezel using the key.



Figure 20. Installing the optional front bezel with the LCD panel



## Drives

Drives are supplied in hot swappable drive carriers that fit in the drive slots.

**CAUTION:** Before attempting to remove or install a drive while the system is running, see the documentation for the storage controller card to ensure that the host adapter is configured correctly.

**CAUTION:** Do not turn off or restart your system while a drive is being formatted. Doing so can cause a drive failure.

When you format a drive, allow enough time for the formatting to complete. Be aware that high-capacity drives can take a long time to format.

## Drives

The PowerEdge R940xa system supports SAS, SATA, Nearline SAS hard drives/SSDs, or NVMe drives.

The supported drive and SSD options for the PowerEdge R940xa system are:

- **8 drives system** - Up to eight 2.5 inch (SAS, SATA or Nearline SAS) front accessible drives in slots 0 through 7.
- **32 drives system** - Up to 24 2.5 inch (SAS, SATA or Nearline SAS) including 4 NVMe front accessible drives in slots 0 to 23 of upper drives bay, and up to eight 2.5 inch (SAS, SATA or Nearline SAS) front accessible drives in slots 24 to 31 of lower drives bay.

## Removing a drive blank

### Prerequisites

1. Follow the safety guidelines listed in [Safety instructions](#).
2. [Remove the Front bezel](#), if installed.

3. Remove the front bezel.

**CAUTION:** To maintain proper system cooling, drive blanks must be installed in all empty drive slots.

**CAUTION:** Mixing drive blanks from previous generations of PowerEdge servers is not supported.

#### Steps

1. Press the release button.
2. Slide the drive blank out of the drive slot.

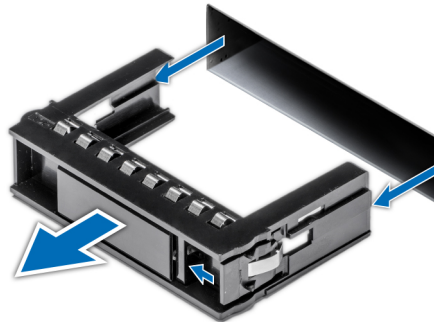

Figure 21. Removing a drive blank

#### Next steps

1. Replace the Drive or a drive blank.

**NOTE:** The procedure to install a drive blank is similar to a drive installation.

## Installing the drive blank

#### Prerequisites

1. Follow the safety guidelines listed in [Safety instructions](#).
2. Remove the front bezel.

**CAUTION:** Mixing drive blanks from previous generations of PowerEdge servers is not supported.

#### Steps

1. Insert the drive blank into the drive slot.
2. Push the blank until the release button clicks into place.

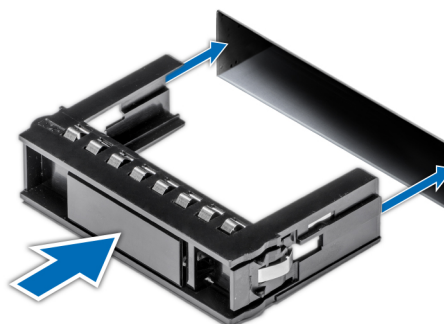

Figure 22. Installing the drive blank

### Next steps

1. [Replace the front bezel.](#)

## Removing a drive carrier

### Prerequisites

1. Follow the safety guidelines listed in [Safety instructions](#).
2. Follow the procedure listed in [Before working inside your system](#).
3. Using the management software, prepare the drive for removal.

If the drive is online, the green activity or fault indicator flashes while the drive is turning off. When the drive indicators are off, the drive is ready for removal. For more information, see the documentation for the storage controller.

**CAUTION:** Before attempting to remove or install a drive while the system is running, see the documentation for the storage controller card to ensure that the host adapter is configured correctly to support drive removal and insertion.

**CAUTION:** Mixing drives from previous generations of PowerEdge servers is not supported.

**CAUTION:** To prevent data loss, ensure that your operating system supports drive installation. See the documentation supplied with your operating system.

4. [Remove the front bezel.](#)

### Steps

1. Press the release button to open the drive carrier release handle.
2. Holding the handle, slide the drive carrier out of the drive slot.



Figure 23. Removing a drive carrier

### Next steps

1. [Replace the drive carrier or drive blank.](#)

# Installing the drive carrier

## Prerequisites

- CAUTION:** Before removing or installing a drive while the system is running, see the documentation for the storage controller card to ensure that the host adapter is configured correctly to support drive removal and insertion.
- CAUTION:** Combining SAS and SATA drives in the same RAID volume is not supported.
- CAUTION:** When installing a drive, ensure that the adjacent drives are fully installed. Inserting a drive carrier and attempting to lock its handle next to a partially installed carrier can damage the partially installed carrier's shield spring and make it unusable.
- NOTE:** Ensure that the drive carrier's release handle is in the open position before inserting the carrier into the slot.
- CAUTION:** To prevent data loss, ensure that your operating system supports hot-swap drive installation. See the documentation supplied with your operating system.
- CAUTION:** When a replacement hot swappable drive is installed and the system is powered on, the drive automatically begins to rebuild. Ensure that the replacement drive is blank or contains data that you wish to overwrite. Any data on the replacement drive is immediately lost after the drive is installed.

1. Follow the safety guidelines listed in [Safety instructions](#).
2. [Remove the front bezel](#).
3. [Remove the drive or drive blank](#).

## Steps

1. Insert the drive carrier into the drive slot and slide until the drive connects with the backplane.
  - NOTE:** To open the release handle, press the release button on the front of the drive carrier.
2. Close the drive carrier release handle to lock the drive in place.



Figure 24. Installing the drive carrier

## Next steps

1. [Replace the front bezel](#).

## Removing the drive from the drive carrier

### Prerequisites

1. Follow the safety guidelines listed in [Safety instructions](#).
2. Follow the procedure listed in [Before working inside your system](#).
3. [Remove the front bezel](#).

### Steps

1. Using a Phillips #1 screwdriver, remove the screws from the slide rails on the drive carrier.

**NOTE:** If the 2.5-inch drive has Torx screw, use Torx 6 screwdriver to remove the drive from a 3.5-inch drive adapter. 

2. Lift the drive out of the drive carrier.



Figure 25. Removing the drive from the drive carrier

### Next steps

1. [Replace the drive into the drive carrier](#).

## Installing the drive into the drive carrier

### Prerequisites

1. [Remove the front bezel](#).

**NOTE:** When installing a drive into the drive carrier, ensure that the screws are torqued to 4 in-lbs.

### Steps

1. Insert the drive into the drive carrier with the connector end of the drive towards the back of the carrier.
2. Align the screw holes on the drive with the screws holes on the drive carrier.
3. Using a Phillips #1 screwdriver, tighten the screws that secure the drive to the drive carrier.

**NOTE:** If the 2.5-inch drive has Torx screw, use Torx 6 screwdriver to install the drive to a 3.5-inch drive adapter. 



**Figure 26. Installing a drive into the drive carrier**

#### **Next steps**

1. [Replace the front bezel.](#)

## **System cover**

System cover provides security for the entire system and also helps in maintaining proper air flow inside the system.

## **Removing the system cover**

#### **Prerequisites**

1. Follow the safety guidelines listed in [Safety instructions](#).
2. Turn off the system, including any attached peripherals.
3. Disconnect the system from the electrical outlet and disconnect the peripherals.

#### **Steps**

1. Use a 1/4 inch flat head or a Phillips #2 screwdriver to turn the latch release lock counterclockwise to the unlock position.
2. Open the latch till the system cover slides back.
3. Lift the cover from the system.



**Figure 27. Removing the system cover**

#### **Next steps**

1. [Replace the system cover.](#)

## **Installing the system cover**

#### **Prerequisites**

1. Follow the safety guidelines listed in [Safety instructions](#).
2. Ensure that all internal cables are routed correctly and connected, and no tools or extra parts are left inside the system.

#### **Steps**

1. Place the system cover on the system.
2. Push the system cover to the front of the system and press the latch down.
3. Use a 1/4 inch flat head or Phillips #2 screwdriver to turn the latch release lock clockwise to the locked position.



**Figure 28. Installing system cover**

### Next steps

1. Follow the procedure listed in [After working inside your system.](#)

## Support bar

The support bar provides support for the chassis walls.

## Removing the support bar

### Prerequisites

1. Follow the safety guidelines listed in [Safety instructions.](#)
2. Follow the procedure listed in [Before working inside your system.](#)

### Steps

1. Loosen the thumb screws on the support bar.
2. Pull the blue release pins inward.
3. Lift the support bar from of the system.



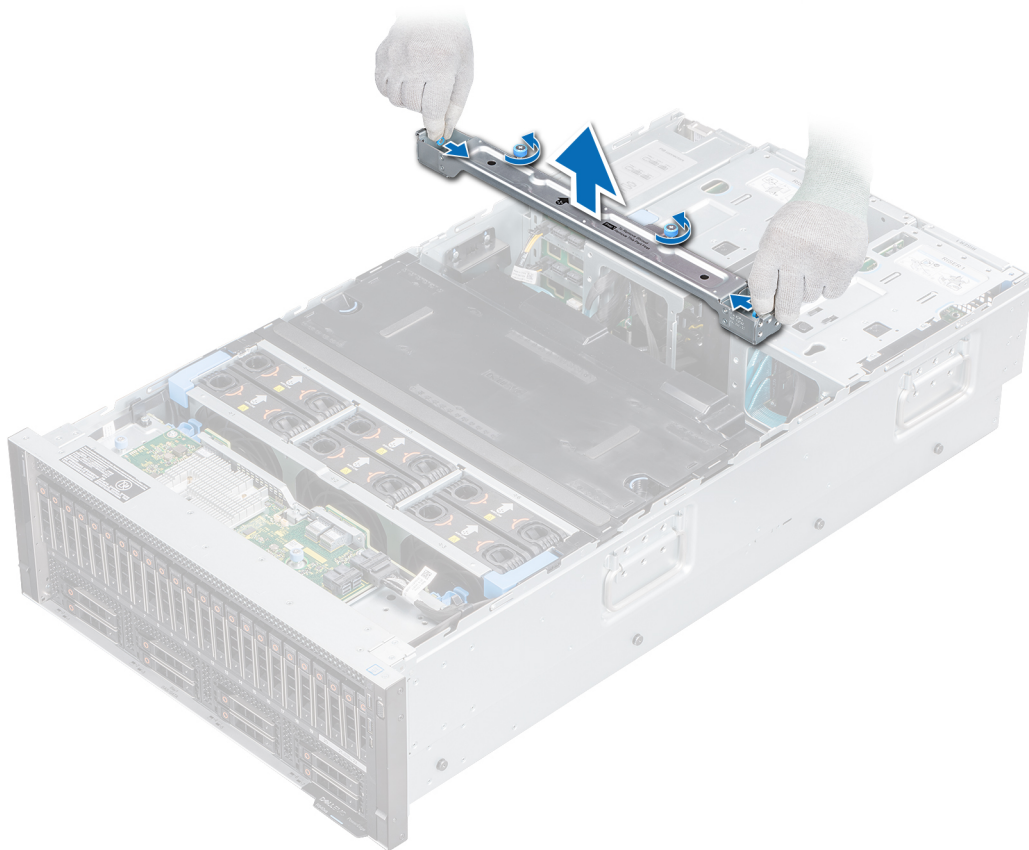

**Figure 29. Removing the support bar**

#### **Next steps**

1. [Replace the support bar.](#)

## **Installing the support bar**

#### **Prerequisites**

1. Follow the safety guidelines listed in [Safety instructions](#).
2. Follow the procedure listed in [Before working inside your system](#).

#### **Steps**

1. Align the support bar slots with the tabs on the system chassis.
2. Pull the blue release pins and lower the support bar into the system until it locks in place.
3. Tighten the thumb screws to secure the support with the chassis.

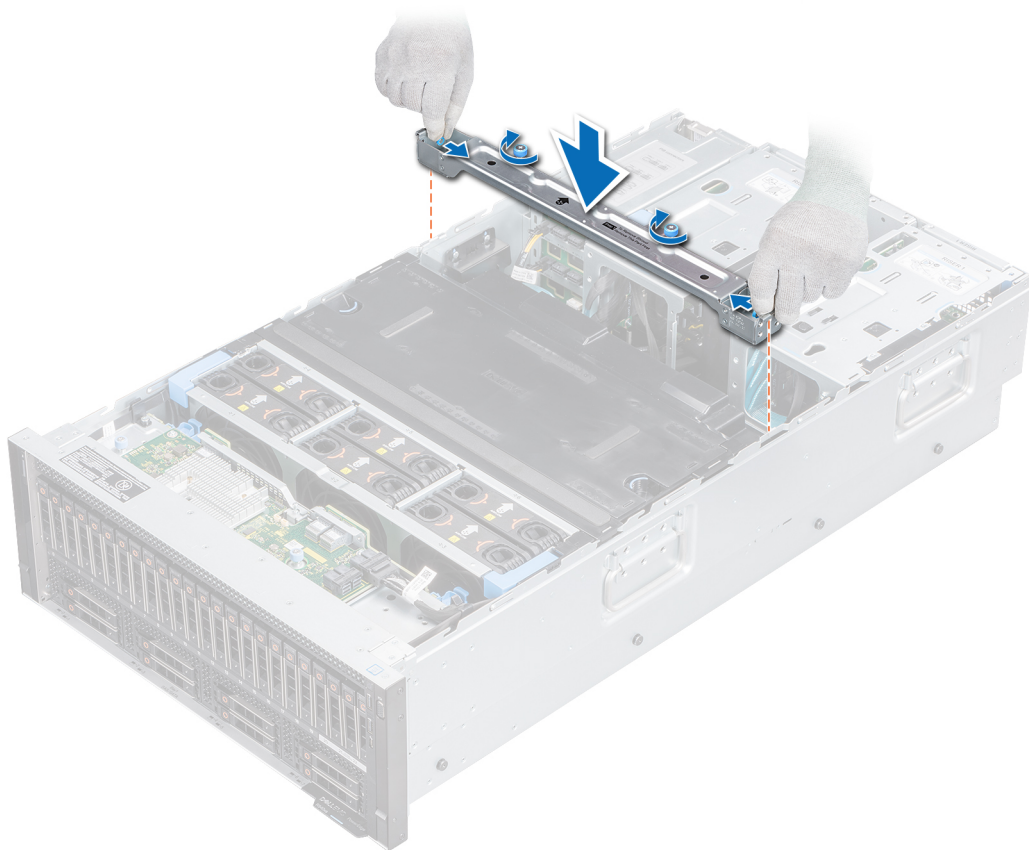

**Figure 30. Installing the support bar**

### Next steps

Follow the procedure listed in [After working inside your system](#).

## Cooling fans

The cooling fans are integrated into the system to dissipate the heat generated by the functioning of the system. These fans provide cooling for the processors, expansion cards, and memory modules.

## Removing the cooling fan

### Prerequisites

**NOTE:** Opening or removing the system cover when the system is on may expose you to a risk of electric shock. Exercise utmost care while removing or installing cooling fans.

**CAUTION:** The cooling fans are hot swappable. To maintain proper cooling while the system is on, replace only one fan at a time.

**CAUTION:** Do not operate the system with the cover removed for a duration exceeding five minutes.

1. Follow the safety guidelines listed in [Safety instructions](#).
2. Follow the procedure listed in [Before working inside your system](#).

### Steps

1. Press the release tab.

2. Lift the cooling fan out of the cooling fan assembly.

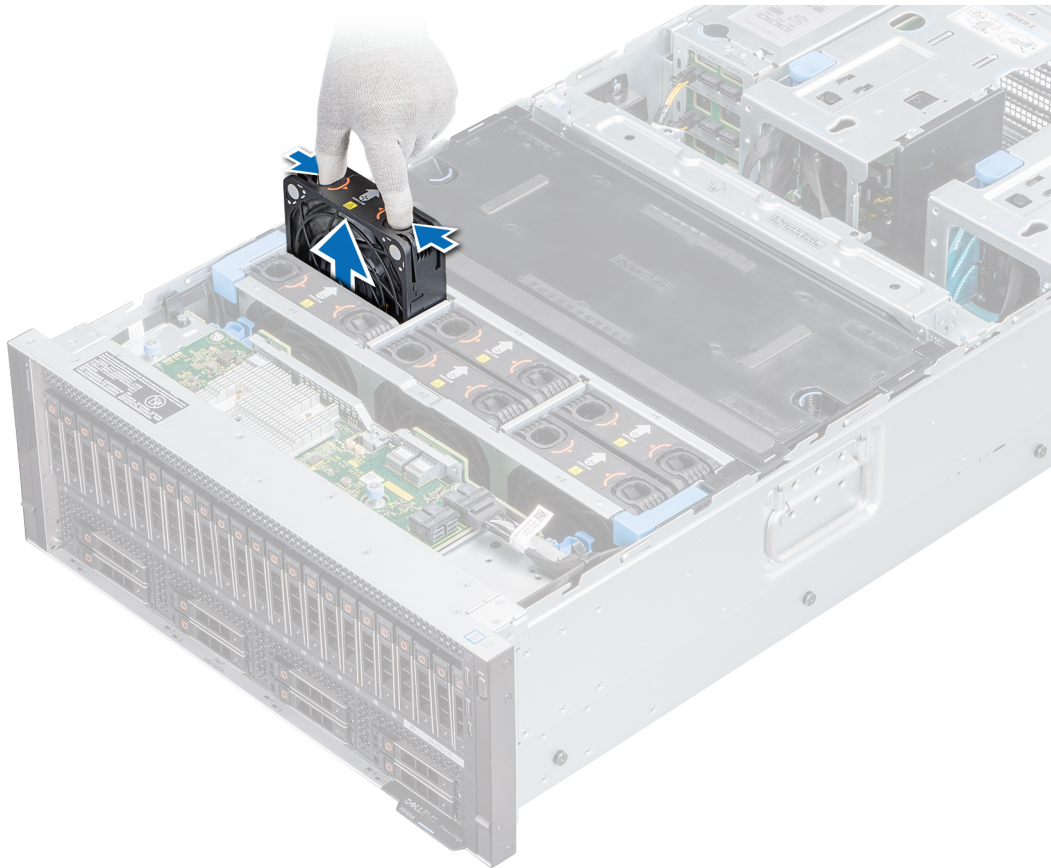

**Figure 31. Removing the cooling fan**

#### Next steps

1. [Replace the cooling fan.](#)

## Installing a cooling fan

#### Prerequisites

**CAUTION:** Opening or removing the system cover when the system is on may expose you to a risk of electric shock. Exercise utmost care while removing or installing cooling fans.

**CAUTION:** The cooling fans are hot swappable. To maintain proper cooling while the system is on, replace only one fan at a time.

**CAUTION:** Do not operate the system with the cover removed for a duration exceeding five minutes.

1. Follow the safety guidelines listed in [Safety instructions](#).

#### Steps

1. Holding the touch points on the cooling fan, align the connector on the cooling fan with the slots in the cooling fan assembly.
2. Slide the cooling fan into the cooling fan assembly until the release tab locks into place.

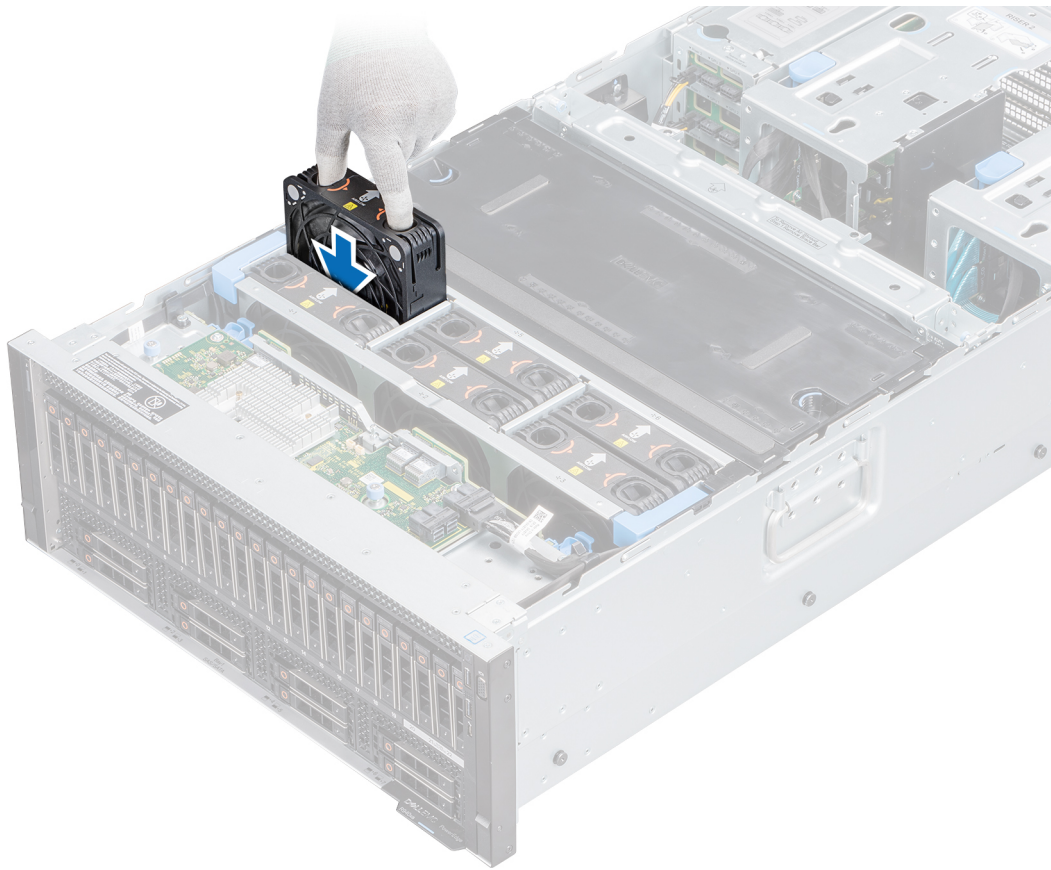

**Figure 32. Installing cooling fan**

#### **Next steps**

1. Follow the procedure listed in [After working inside your system.](#)

## **Cooling fan assembly**

The cooling fan assembly houses the array of cooling fans. A failure in the server's cooling system can result in the server overheating and may lead to damage.

## **Removing the cooling fan assembly**

#### **Prerequisites**

1. Follow the safety guidelines listed in [Safety instructions.](#)
2. Follow the procedure listed in [Before working inside your system.](#)

#### **Steps**

1. Lift the release levers to unlock the cooling fan assembly.
2. Hold the release levers, and lift the cooling fan assembly out of the system.

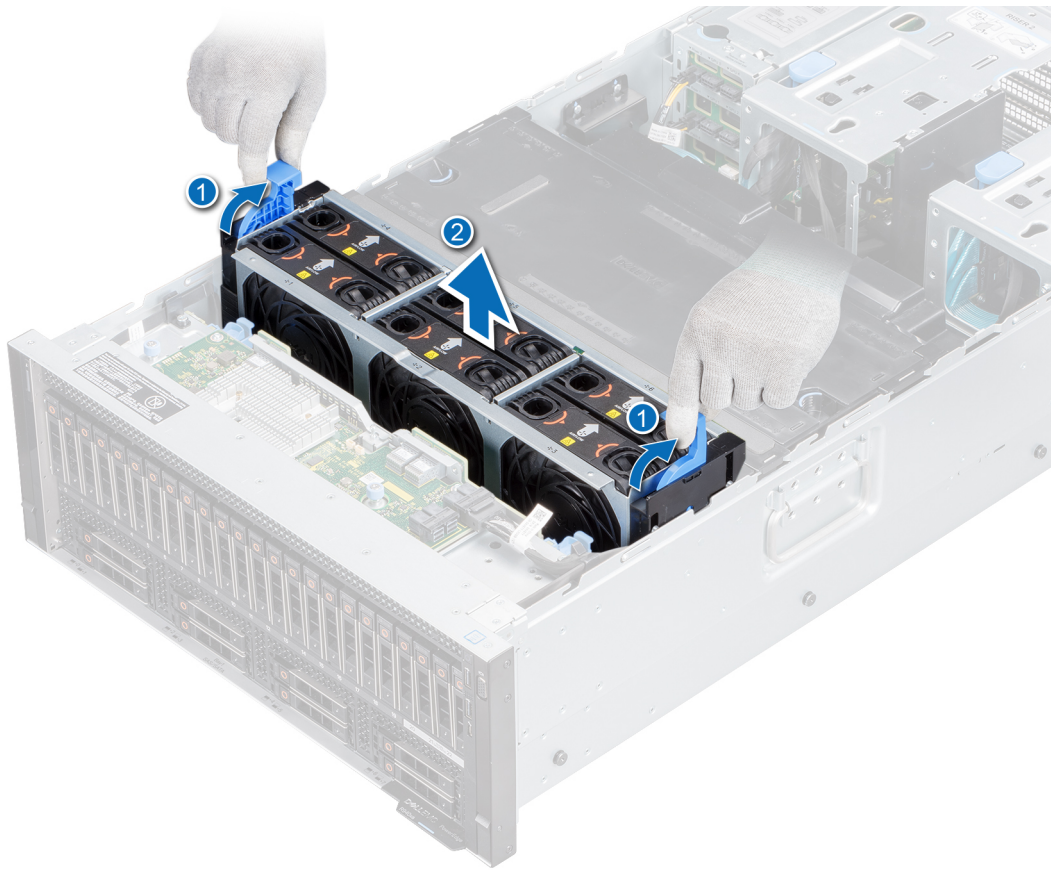

Figure 33. Removing the cooling fan assembly

#### Next steps

1. [Replace the cooling fan assembly.](#)

## Installing the cooling fan assembly

#### Prerequisites

1. Follow the safety guidelines listed in [Safety instructions](#).
2. Follow the procedure listed in [Before working inside your system](#).

 **CAUTION:** Observe the routing of the cable as you remove it from the system. Route the cable properly when you replace it to prevent the cable from being pinched or crimped.

#### Steps

1. Align the guide slots on the cooling fan assembly with the standoffs on the system.
2. Lower the cooling fan assembly into the system until the cooling fan connectors engage with the connectors on the system board.
3. Press the release levers to lock the cooling fan assembly in place.

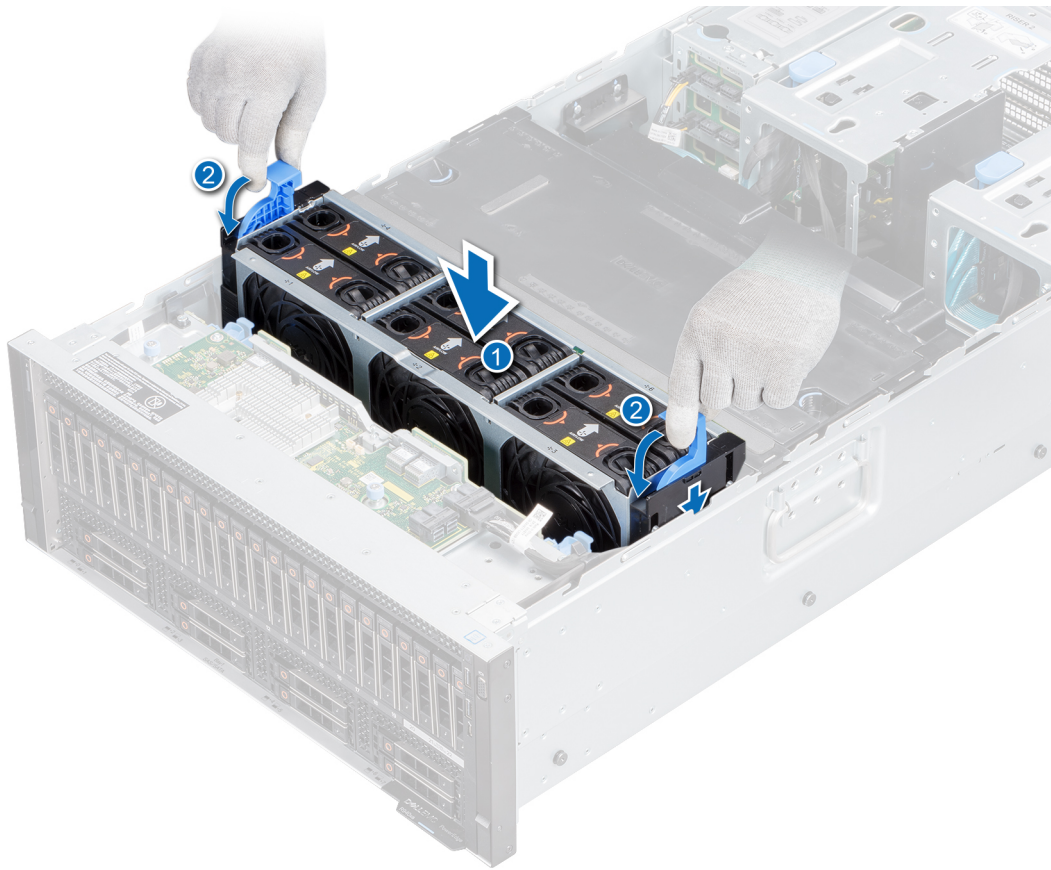

**Figure 34. Installing the cooling fan assembly**

#### **Next steps**

1. Follow the procedure listed in [After working inside your system](#).

## **Optional USB 3.0 module**

An additional USB 3.0 port can be added to the front of the system. The USB 3.0 module cable connects to the internal USB port on the system board. The default internal USB port is available under the expansion riser 2.

The internal USB memory key is supported only in the 8 x 2.5 inch hard-drive configuration.

## **Removing the USB 3.0 module**

#### **Prerequisites**

1. Follow the safety guidelines listed in [Safety instructions](#).
2. Follow the procedure listed in [Before working inside your system](#).
3. [Remove the front bezel](#).
4. [Remove the support bar](#).
5. [Remove the air shrouds](#).
6. [Remove the cooling fan assembly](#).

#### **Steps**

1. Disconnect the cables from the system board.
2. Using a Phillips #2 screwdriver, loosen the screw on the USB 3.0 module.

3. **NOTE:** Observe the routing of the cable as you remove it from the system. Route the cable properly when you replace it to prevent the cable from being pinched or crimped.

Slide the USB 3.0 module out of the system.

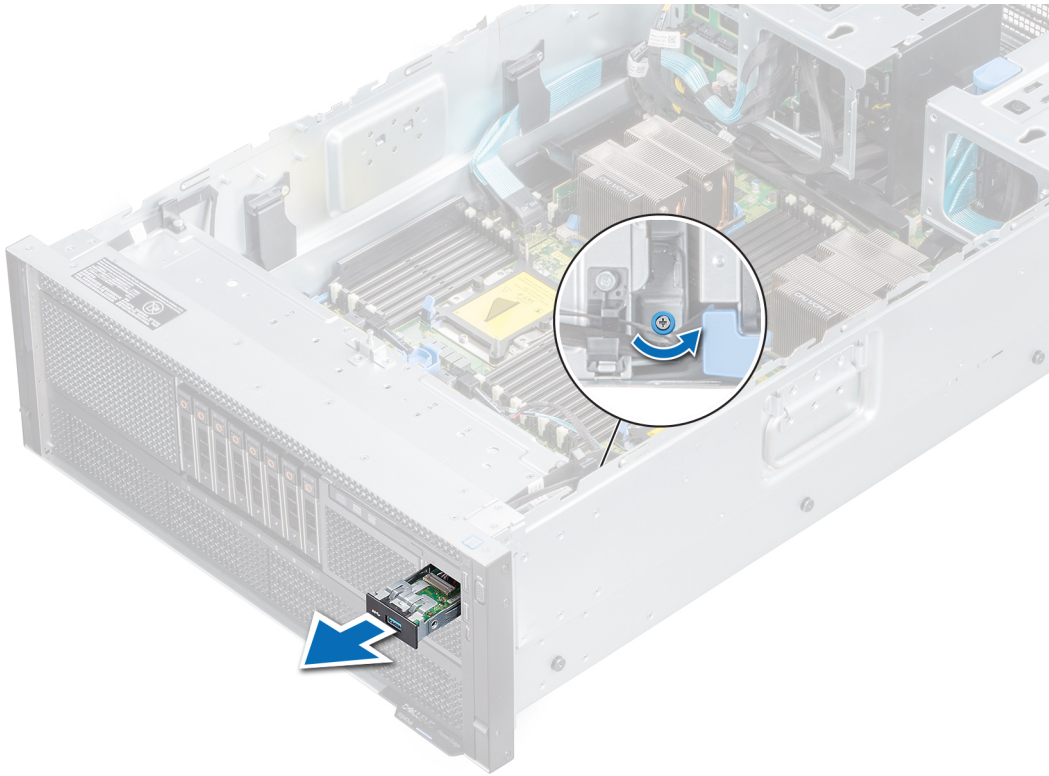

**Figure 35. Removing USB 3.0 module**

#### Next steps

1. [Replace the USB 3.0 module or the USB 3.0 blank.](#)

**NOTE:** The procedure to remove a USB 3.0 blank is similar to the USB 3.0 module.

## Installing the USB 3.0 module

#### Prerequisites

1. Follow the safety guidelines listed in [Safety instructions](#).
2. Follow the procedure listed in [Before working inside your system](#).
3. [Remove the front bezel.](#)
4. [Remove the support bar.](#)
5. [Remove the air shrouds.](#)
6. [Remove the cooling fan assembly.](#)

#### Steps

1. Route the power and the USB cables on the USB 3.0 module through the USB 3.0 module slot on the front of the system.
2. Insert the USB 3.0 module into the slot on the front panel.
3. Align the screw on the module with the screw hole on the system.
4. Using a Phillips #2 screwdriver, tighten the screw to secure the module to the system.
5. Route and connect the USB cable to the internal USB port and power cable to the system board.

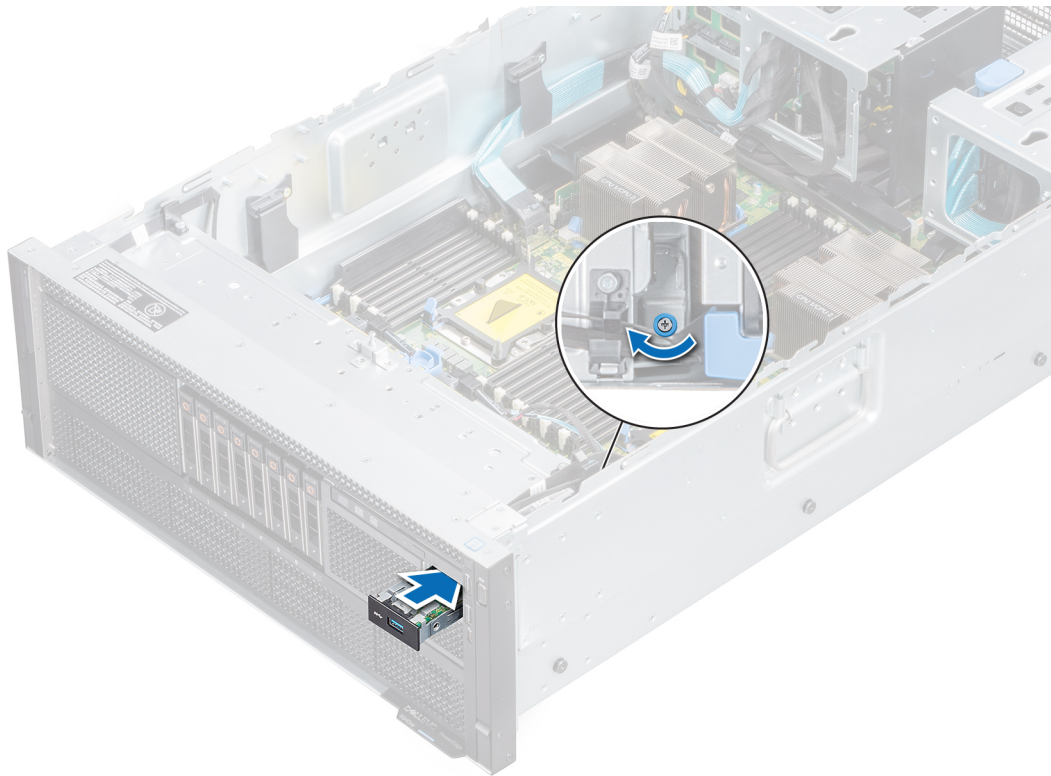

**Figure 36. Installing the USB 3.0 module**

**NOTE:** To locate the connector, see [System board connectors](#).

#### Next steps

1. [Replace the cooling fan assembly.](#)
2. [Replace the air shrouds.](#)
3. [Replace the support bar.](#)
4. [Replace the front bezel.](#)
5. Follow the procedure listed in [After working inside your system.](#)

## Optional optical drive

Optical drives retrieve and store data on optical discs such as CD and DVD. Optical drives can be categorized into two basic types: optical disc readers and optical disc writers.

The optical drive is supported only in the 8 x 2.5 inch hard-drive configuration.

## Removing the optical drive

#### Prerequisites

1. Follow the safety guidelines listed in [Safety instructions](#).
2. Follow the procedure listed in [Before working inside your system](#).
3. [Remove the front bezel.](#)
4. [Remove the support bar.](#)
5. [Remove the air shrouds.](#)
6. [Remove the cooling fan assembly.](#)
7. Disconnect the power and data cables from the connectors on the optical drive.



**NOTE:** Ensure that you note the routing of the power and data cable on the side of the system as you remove them from the system board and drive.

### Steps

1. Press the release tab to release the optical drive.
2. Slide the optical drive out of the system.

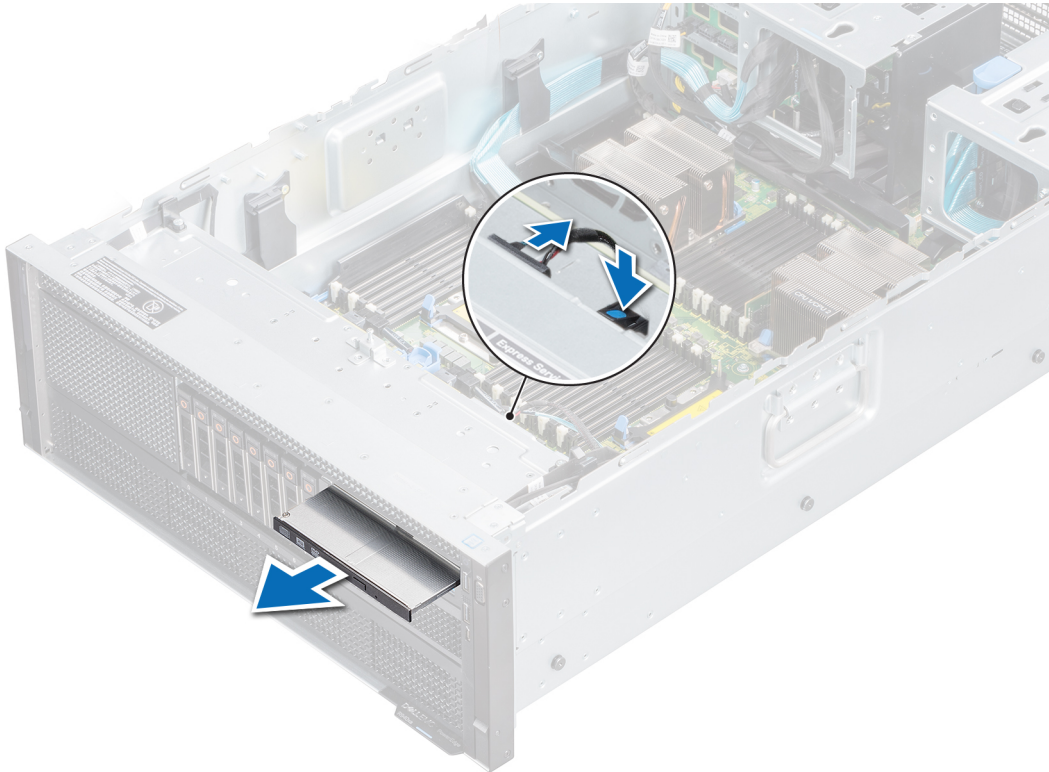

**Figure 37. Removing optical drive**

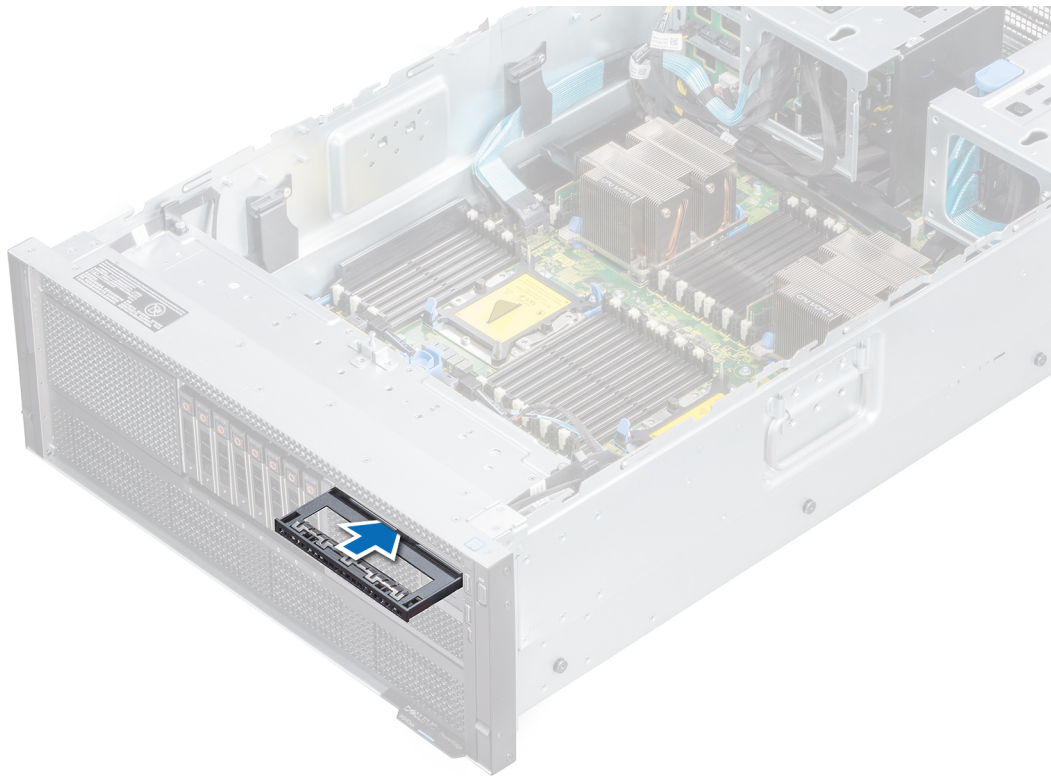

**Figure 38. Installing optical drive blank**

#### **Next steps**

1. [Replace the optical drive.](#)

## **Installing the optical drive**

#### **Prerequisites**

1. Follow the safety guidelines listed in [Safety instructions](#).
2. Follow the procedure listed in [Before working inside your system](#).
3. [Remove the front bezel](#).
4. [Remove the support bar](#).
5. [Remove the air shroud](#).
6. [Remove the cooling fan assembly](#).

#### **Steps**

1. If installed, remove the optical drive blank.

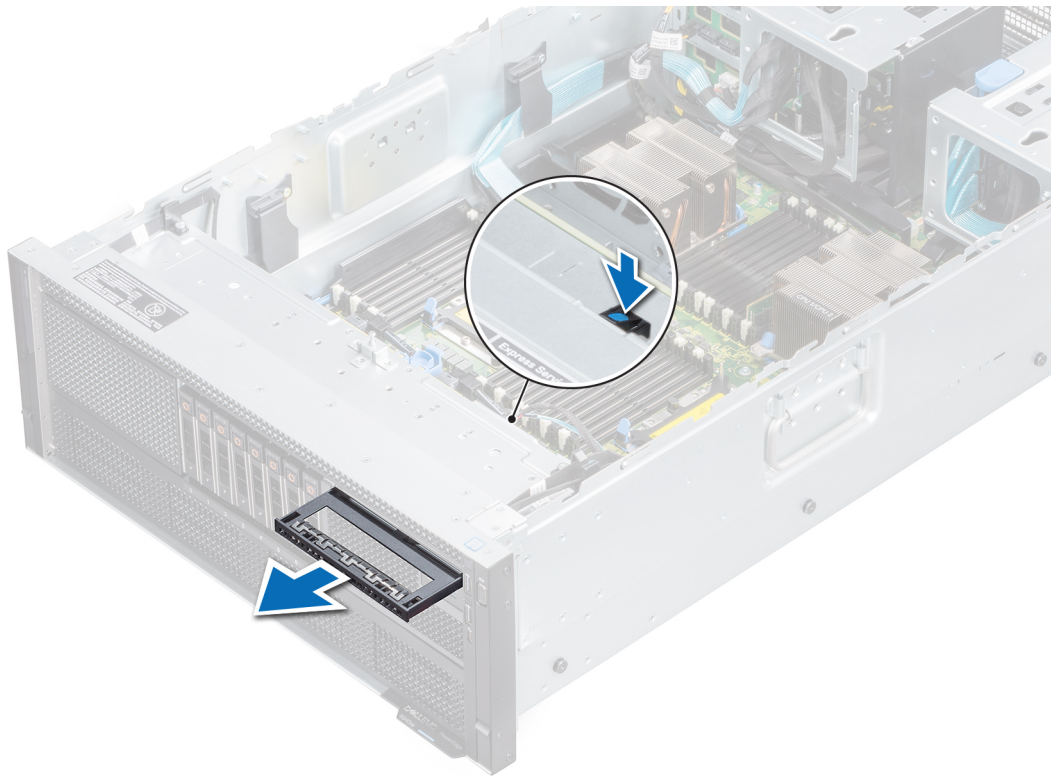

**Figure 39. Removing the optical drive blank**

2. Align the optical drive with the optical drive slot on the front of the system.
3. Slide in the optical drive until the release tab snaps into place.

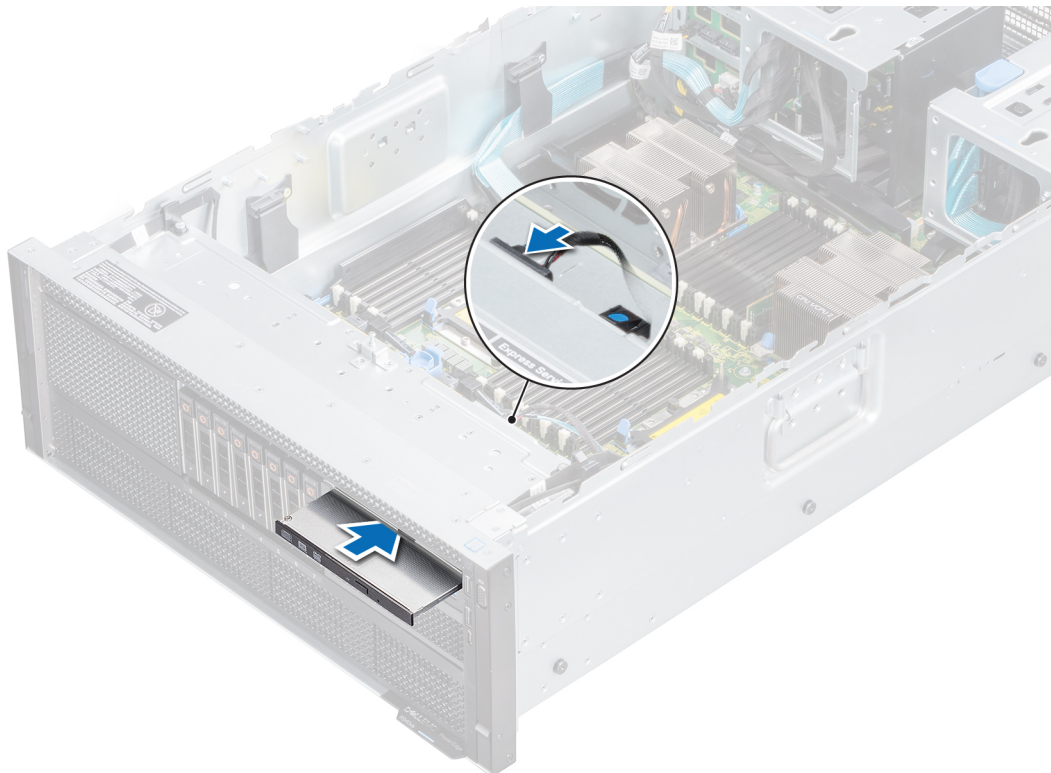

**Figure 40. Installing the optical drive**

### Next steps

1. Connect the power and data cables to the connector on the optical drive and the connector on the system board.  
**i** **NOTE:** Route the cable properly on the side of the system to prevent it from being pinched or crimped.
2. [Replace the cooling fan assembly.](#)
3. [Replace the air shrouds.](#)
4. [Replace the support bar.](#)
5. [Replace the front bezel.](#)
6. Follow the procedure listed in [After working inside your system.](#)

## Control panel

A control panel allows you to manually control the inputs to the server.

Your system supports:

- Left control panel: Contains status LEDs, system ID button, and iDRAC Quick Sync 2 (optional).
- Right control panel: Contains power button, USB 2.0 port, VGA port, micro USB for iDRAC Direct, and status LED for iDRAC Direct.

## Removing the left control panel

### Prerequisites

1. Follow the safety guidelines listed in [Safety instructions.](#)
2. Follow the procedure listed in [Before working inside your system.](#)
3. [Remove the front bezel.](#)
4. [Remove the support bar.](#)
5. [Remove the air shrouds.](#)
6. [Remove the cooling fan assembly.](#)

### Steps

1. Lift the cable latch and disconnect the control panel cable from the system board connector.  
**i** **NOTE:** Ensure that you note the routing of the cables as you remove them from the system.
2. Using a Phillips #1 screwdriver, remove the screws that secure cable cover and remove it from the system.
3. Remove the screws that secure the control panel and ribbon cable to the system.
4. Holding the control panel and ribbon cable, remove the control panel and ribbon cable away from the system.

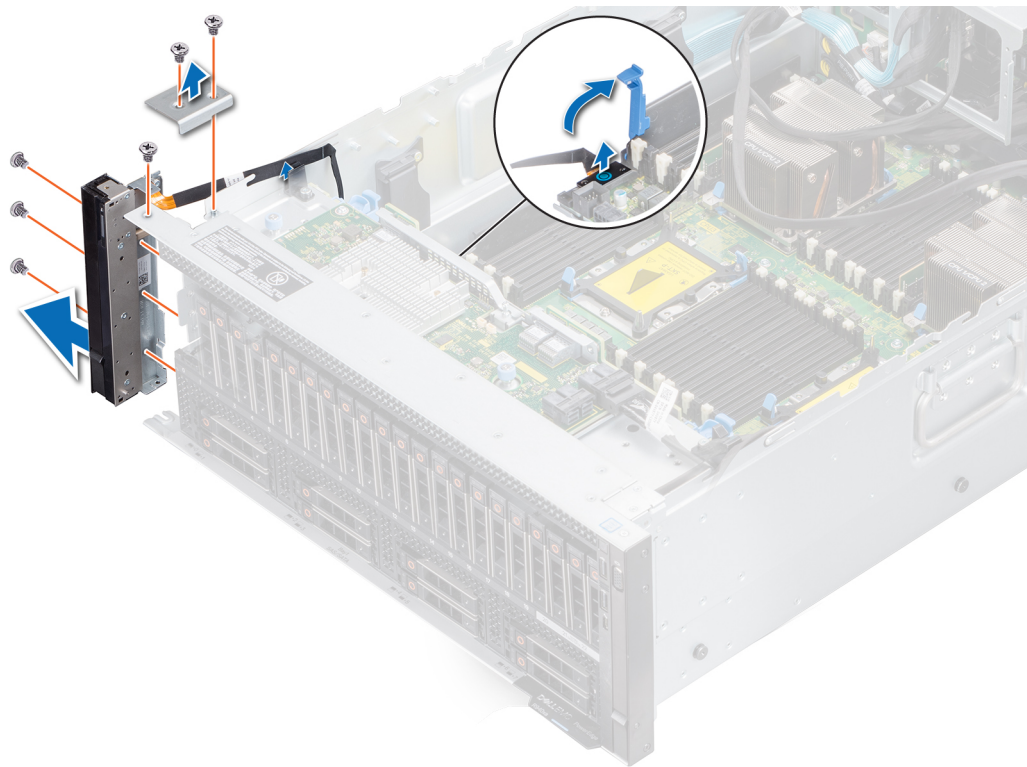

**Figure 41. Removing left control panel**

#### Next steps

1. [Replace the left control panel.](#)

## Installing the left control panel

#### Prerequisites

1. Follow the safety guidelines listed in [Safety instructions](#).
2. Follow the procedure listed in [Before working inside your system](#).
3. [Remove the front bezel.](#)
4. [Remove the support bar.](#)
5. [Remove the air shrouds.](#)
6. [Remove the cooling fan assembly.](#)

#### Steps

1. Route the control panel cable through the side wall of the system.
2. Align the control panel assembly with the control panel slot on the system and place the assembly in the slot on the system.
3. Connect the control panel cable to the system board connector and secure it using cable latch.

**NOTE:** Route the cables properly when you replace them to prevent them from being pinched or crimped.

4. Using a Phillips #1 screwdriver, install the screws that secure the control panel and ribbon cable to the system.

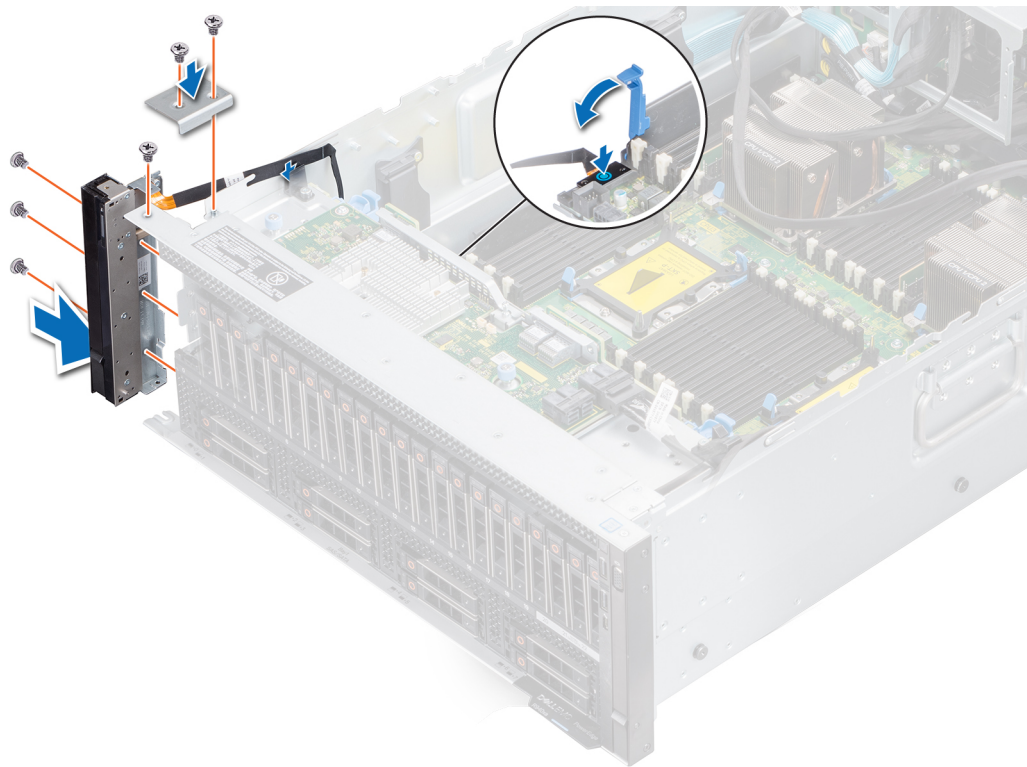

**Figure 42. Installing the left control panel**

#### **Next steps**

1. [Replace the cooling fan assembly.](#)
2. [Replace the air shrouds.](#)
3. [Replace the support bar.](#)
4. [Replace the front bezel.](#)
5. Follow the procedure listed in [After working inside your system.](#)

## **Removing the right control panel**

#### **Prerequisites**

1. Follow the safety guidelines listed in [Safety instructions.](#)
2. Follow the procedure listed in [Before working inside your system.](#)
3. [Remove the front bezel.](#)
4. [Remove the support bar.](#)
5. [Remove the air shroud.](#)
6. [Remove the cooling fan assembly.](#)

#### **Steps**

1. Disconnect the VGA cable from the system board.
2. Lift the cable latch and disconnect the control panel cable from the system board connector.
3. Using a Phillips #1 screwdriver, remove the screws that secure cable cover and remove it from the system.
4. Remove the screws that secure the control panel and ribbon cable to the system.
5. Holding the control panel and ribbon cable, remove the control panel and ribbon cable away from the system.

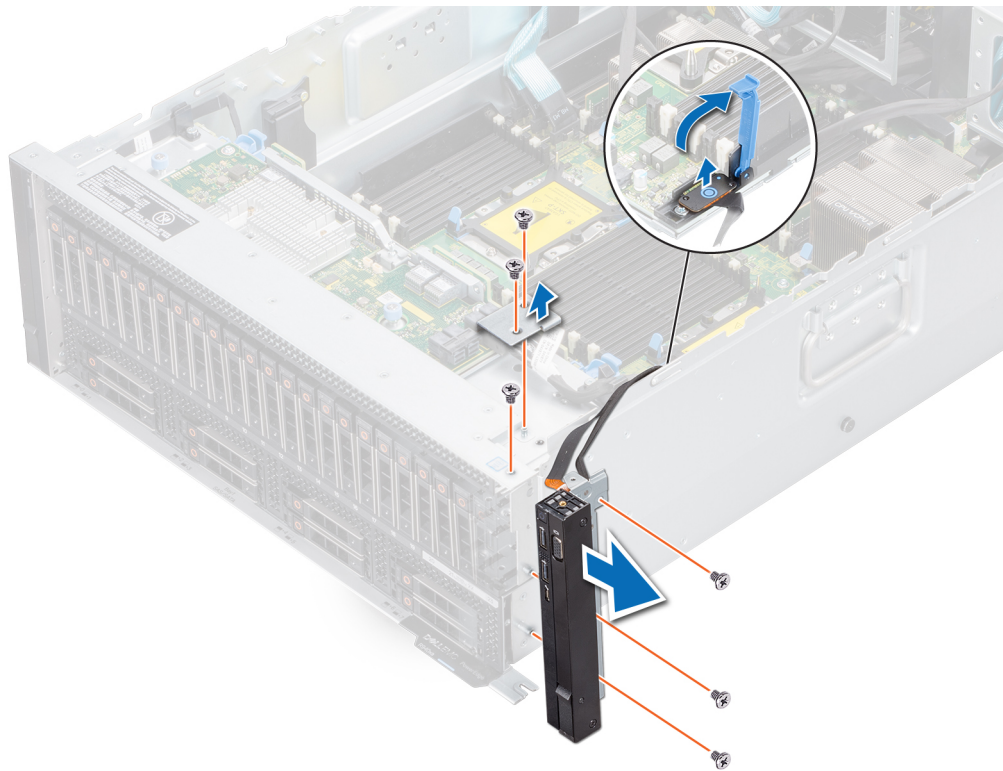

**Figure 43. Removing right control panel**

#### **Next steps**

1. [Replace the right control panel.](#)

## **Installing the right control panel**

#### **Prerequisites**

1. Follow the safety guidelines listed in [Safety instructions](#).
2. Follow the procedure listed in [Before working inside your system](#).
3. [Remove the front bezel.](#)
4. [Remove the support bar.](#)
5. [Remove the air shroud.](#)
6. [Remove the cooling fan assembly.](#)

#### **Steps**

1. Route the control panel cable through the side wall of the system.
2. Align the control panel assembly with the control panel slot on the system and place the assembly in the slot on the system.
3. Connect the VGA cable to the system board.
4. Connect the control panel cable to the system board connector and secure it using cable latch.
5. Using a Phillips #1 screwdriver, install the screws that secure the control panel and ribbon cable to the system.

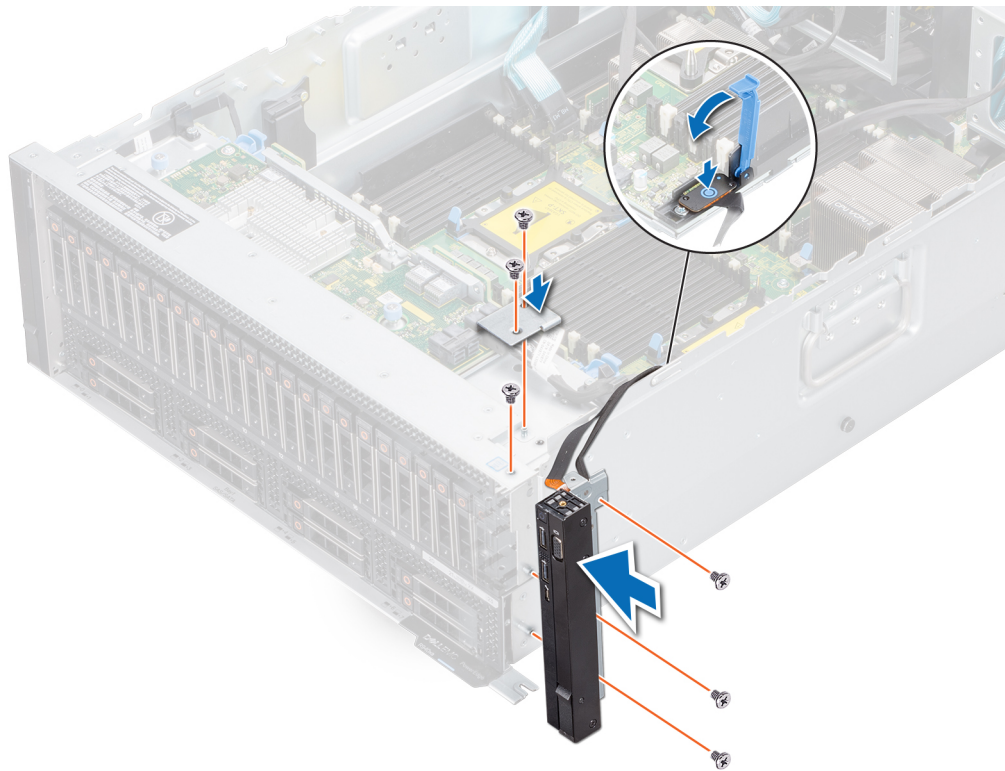

**Figure 44. Installing right control panel**

**Next steps**

1. [Replace the cooling fan assembly.](#)
2. [Replace the air shrouds.](#)
3. [Replace the support bar.](#)
4. [Replace the front bezel.](#)
5. Follow the procedure listed in [After working inside your system.](#)



# Air shroud

The air shroud directs the airflow across the entire system. The air shrouds maintain uniform airflow inside the system

The PowerEdge R940xa has four air shrouds as mentioned below:

 **NOTE:** Ensure that you install or remove the air shrouds in the order mentioned below:

1. Air shroud A
2. GPU shroud
3. Air shroud B
4. Air shroud C

# Air shroud A

## Removing the air shroud A

### Prerequisites

**CAUTION:** Never operate your system without the air shroud. The system may get overheated quickly, resulting in shutdown of the system and loss of data.

1. Follow the safety guidelines listed in [Safety instructions](#).
2. Follow the procedure listed in [Before working inside your system](#).
3. [Remove the support bar](#).

### Steps

1. Press the blue release latches.
2. Lift the air shroud out of the system.

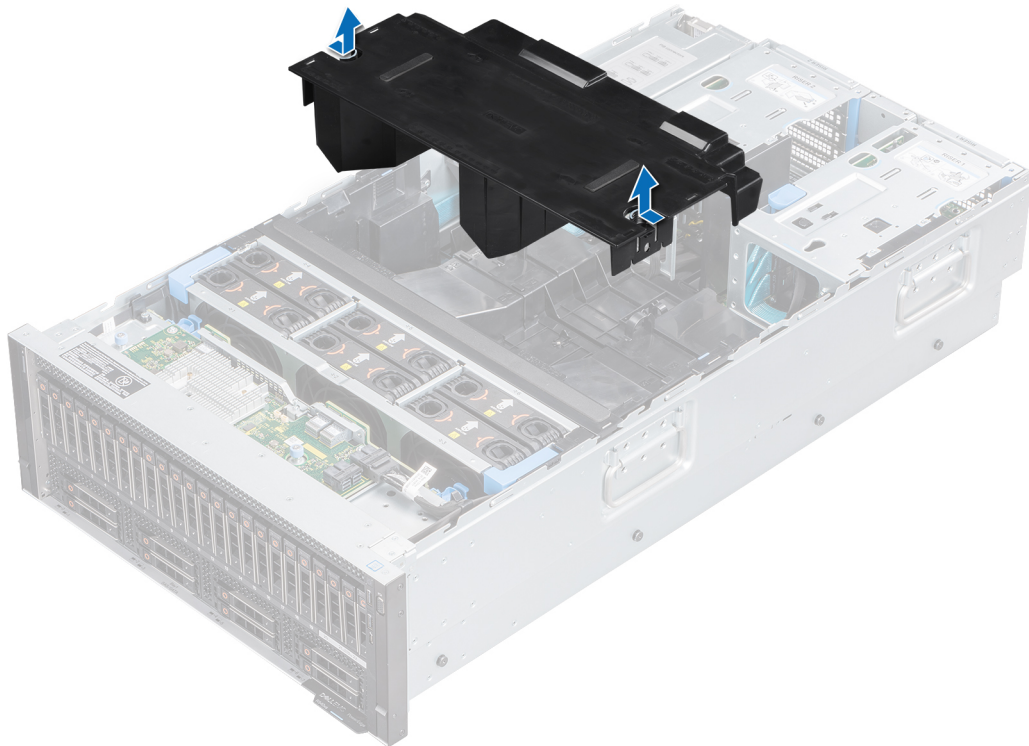

Figure 45. Removing the air shroud A

### Next steps

1. [Replace the air shroud A](#).

## Installing the air shroud A

### Prerequisites

1. Follow the safety guidelines listed in [Safety instructions](#).
2. Follow the procedure listed in [Before working inside your system](#).

3. Remove the support bar.
4. If applicable, route the cables inside the system along the system wall and secure the cables by using the cable latch.

### Steps

1. Align the slots on air shroud A with the guides on shroud B.
2. Lower the air shroud into the system until the blue release tabs locks in place .

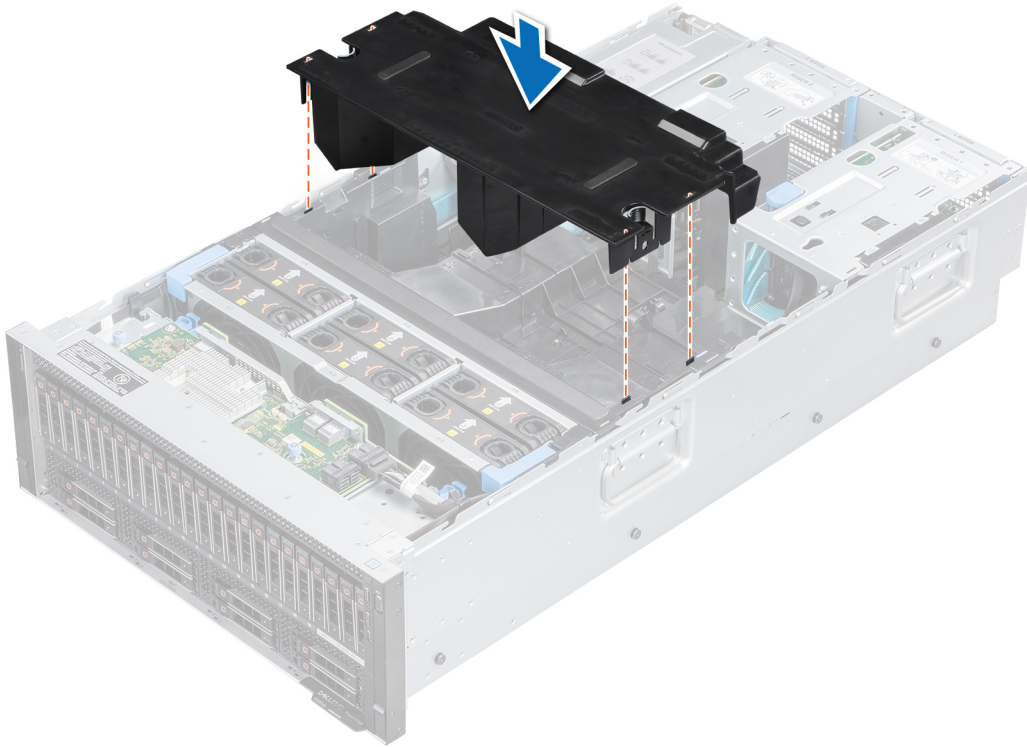

**Figure 46. Installing the air shroud A**

### Next steps

1. Replace the support bar.
2. Follow the procedure listed in [After working inside your system.](#)

# GPU shroud

## Removing the GPU shroud

### Prerequisites

**NOTE:** The GPU shroud must be removed only when a GPU is installed in the system.

1. Follow the safety guidelines listed in [Safety instructions](#).
2. Follow the procedure listed in [Before working inside your system](#).
3. [Remove the support bar](#).
4. [Remove the air shroud A](#).

### Steps

1. Hold the GPU shroud by the edges on either side of the touch points.
2. Lift it from the system.

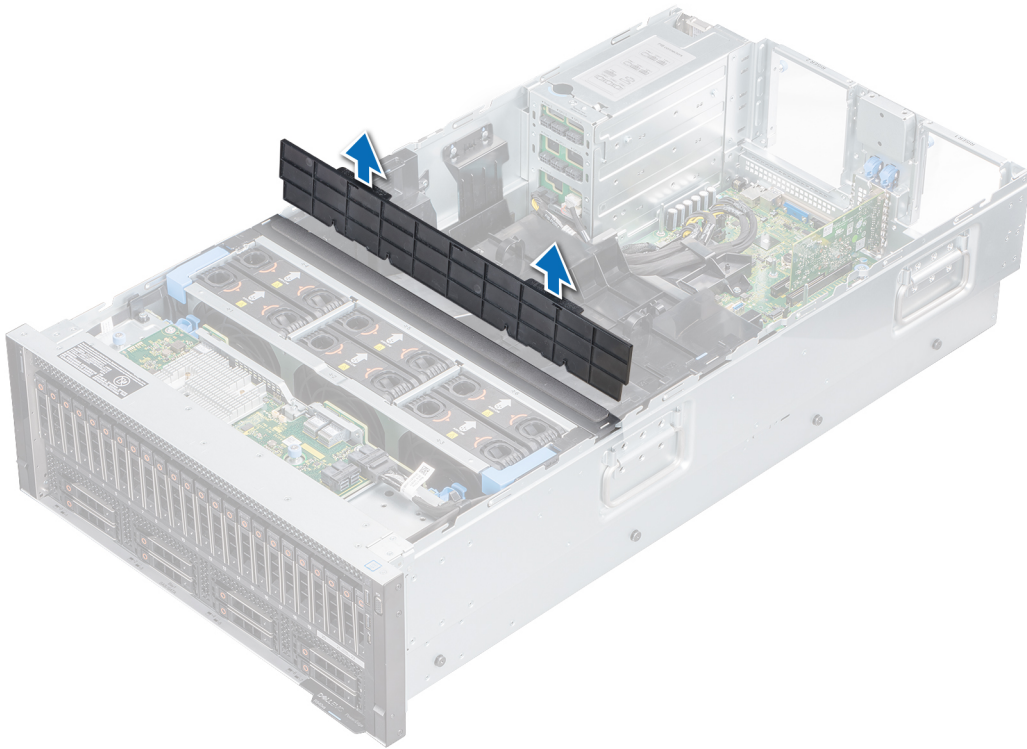

Figure 47. Removing the GPU Shroud

### Next steps

1. [Install the GPU](#).

## Installing the GPU shroud

### Prerequisites

1. Follow the safety guidelines listed in [Safety instructions](#).

2. Follow the procedure listed in [Before working inside your system](#).
3. [Remove the support bar](#).
4. [Remove the air shroud A](#).
5. Route the cables inside the system along the system wall and secure the cables by using the cable latch.

### Steps

1. Align the slots on the GPU shroud with the tabs on air shroud B.
2. Lower the GPU shroud into the system until it is firmly seated.

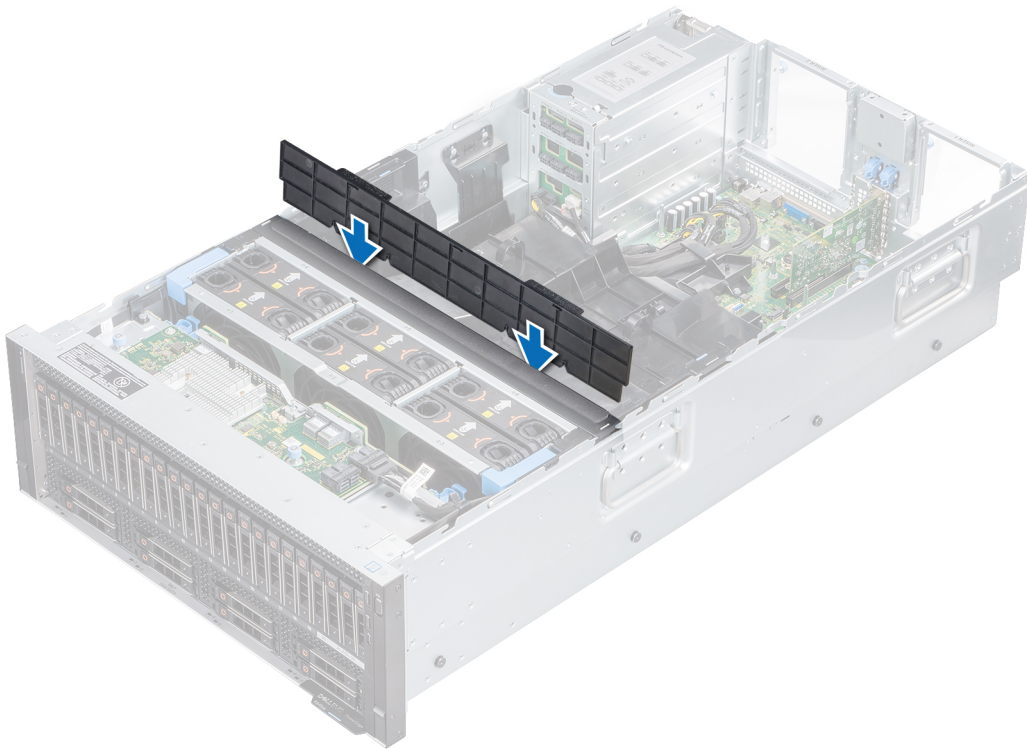

**Figure 48. Installing the GPU shroud**

### Next steps

1. [Replace the air shroud A](#)
2. [Replace the support bar](#)
3. Follow the procedure listed in [After working inside your system](#).

# Air shroud B

## Removing the air shroud B

### Prerequisites

1. Follow the safety guidelines listed in [Safety instructions](#).
2. Follow the procedure listed in [Before working inside your system](#).
3. [Remove the support bar](#).
4. [Remove the air shroud A](#).
5. [Remove the NVDIMM-N battery](#), if installed.

### Steps

1. Hold the air shroud on the blue touch points.
2. Lift it out of the system.

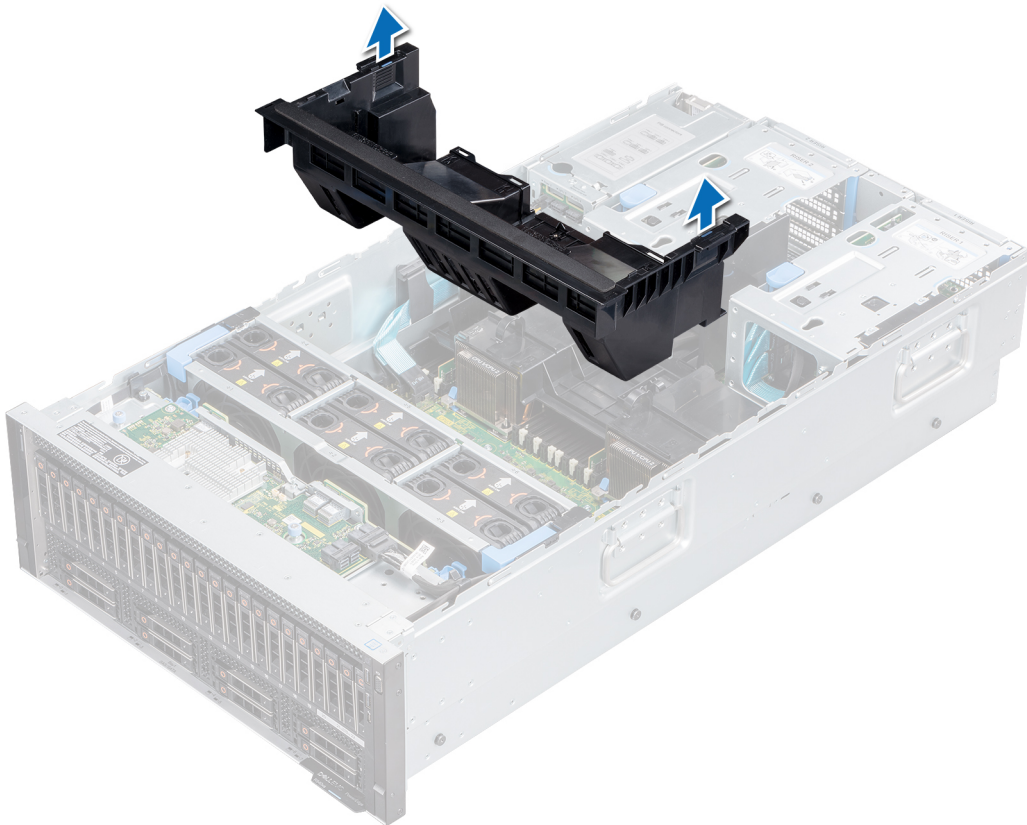

Figure 49. Removing the Air Shroud B

### Next steps

1. [Replace the air shroud B](#).

## Installing the air shroud B

### Prerequisites

1. Follow the safety guidelines listed in [Safety instructions](#).

2. Follow the procedure listed in [Before working inside your system](#).
3. If applicable, route the cables inside the system along the system wall and secure the cables by using the cable latch.
4. [Remove the support bar](#).
5. [Remove the air shroud A](#).

### Steps

1. Align the slots on the air shroud with the tabs on the system chassis and air shroud C.
2. Lower the air shroud into the system until it is firmly seated.

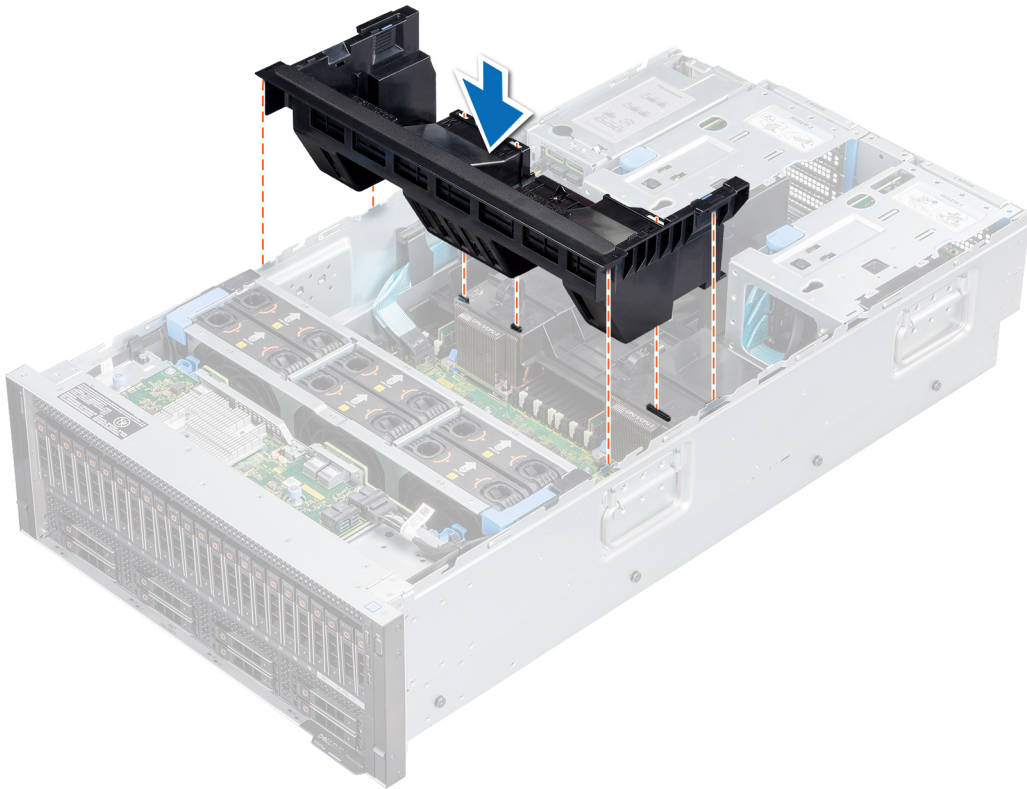

**Figure 50. Installing the air shroud B**

### Next steps

1. [Replace the NVDIMM-N battery](#).
2. [Replace the air shroud A](#)
3. [Replace the support bar](#)
4. Follow the procedure listed in [After working inside your system](#).

# Air shroud C

## Removing the Air Shroud C

### Prerequisites

**CAUTION:** Ensure that the riser 1 cables do not get pinched or crimped while placing the air shroud C.

1. Follow the safety guidelines listed in [Safety instructions](#).
2. Follow the procedure listed in [Before working inside your system](#).
3. Remove the support bar.
4. Remove the air shrouds A.
5. Remove the NVDIMM-N battery, if installed.
6. Remove the air shroud B.

### Steps

1. Release the cables from the cable retention clips on the shroud.
2. Disengage the air shroud from the retention tabs on the left side of the chassis wall.
3. Lift the air shroud out of the system.

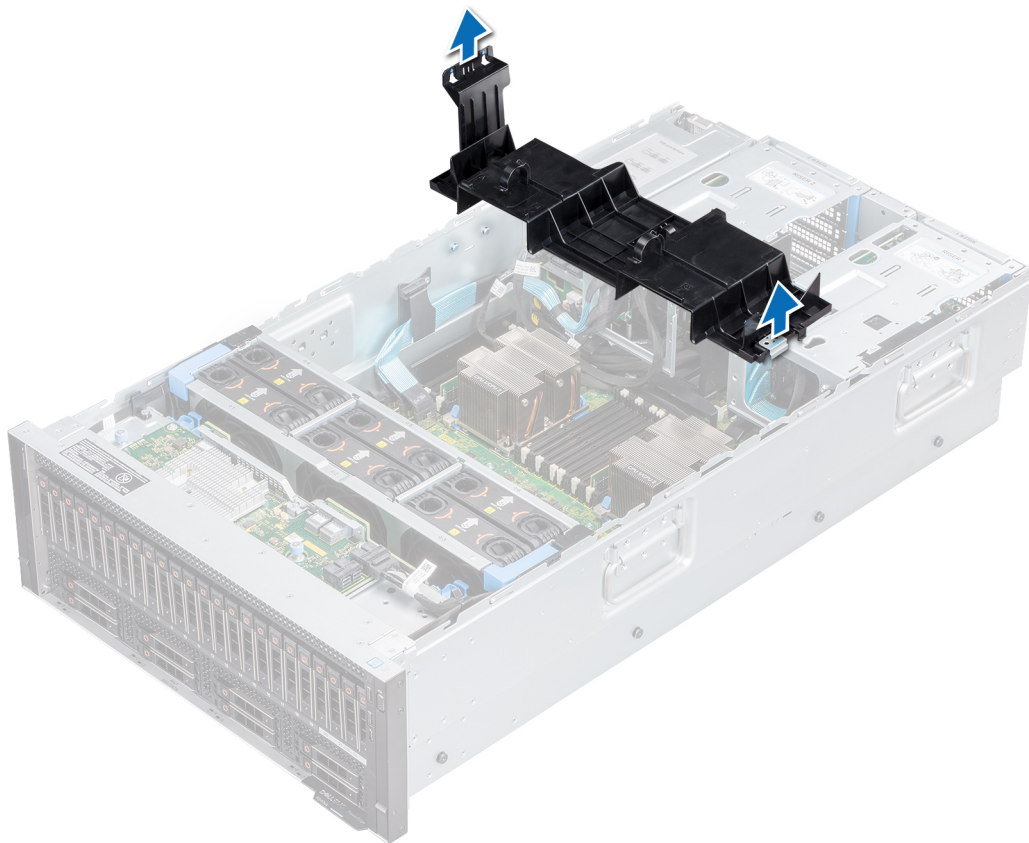

Figure 51. Removing the Air Shroud C

### Next steps

1. [Replace the air shroud C.](#)



## Installing the air shroud C

### Prerequisites

1. Follow the safety guidelines listed in [Safety instructions](#).
2. Follow the procedure listed in [Before working inside your system](#).
3. [Remove the support bar](#).
4. [Remove the air shrouds A](#).
5. [Remove the air shroud B](#).

### Steps

1. Align the metal tab on the air shroud with the slot on the chassis wall.
2. Align and push down to seat the shroud firmly on the chassis wall retention tab.

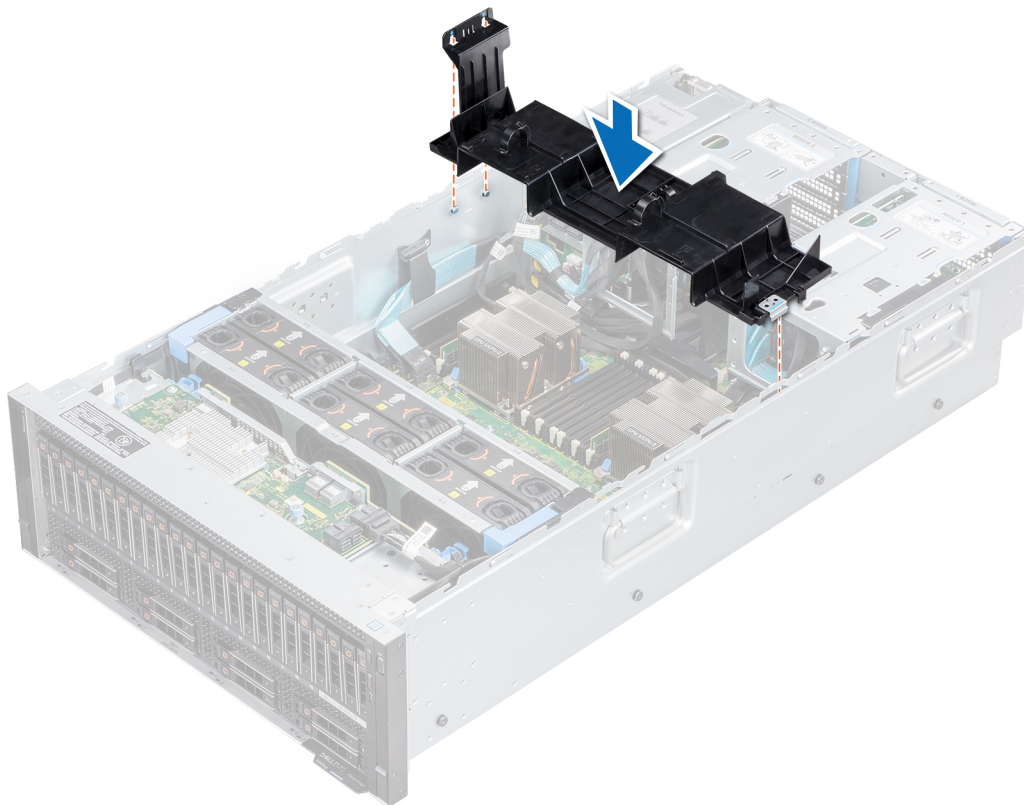

**Figure 52. Installing the air shroud C**

### Next steps

1. [Replace the air shroud B](#)
2. [Replace the NVDIMM-N battery](#).
3. [Replace the air shroud A](#)
4. [Replace the support bar](#)
5. Follow the procedure listed in [After working inside your system](#).

# NVDIMM-N battery

This section contains information about the removal and installation of the NVDIMM battery from the air shroud. NVDIMM-N battery is installed on the air shroud.

## Removing the NVDIMM-N battery

### Prerequisites

1. Follow the safety guidelines listed in [Safety instructions](#).
2. Follow the procedure listed in [Before working inside your system](#).
  - ⚠ **CAUTION: NVDIMM-N battery is not hot swappable. To prevent data loss and potential damage to your system, ensure that your system, LEDs on system, LEDs on NVDIMM-N and LEDs on NVDIMM-N battery are turned off before removing the NVDIMM-N battery.**
  - ⚠ **CAUTION: To avoid damage to the battery connector, you must firmly support the connector while installing or removing a battery.**
3. [Remove the support bar](#).
4. [Remove the air shroud A](#).

### Steps

1. Disconnect the battery backup cable, and the NVDIMM connector cable from the NVDIMM-N battery.
2. Using a Phillips #2 screwdriver, loosen the screw securing the NVDIMM-N battery.
3. Lift the NVDIMM-N battery at an angle to disengage it from the slot on the air shroud.
4. Lift the NVDIMM-N battery out of the system.

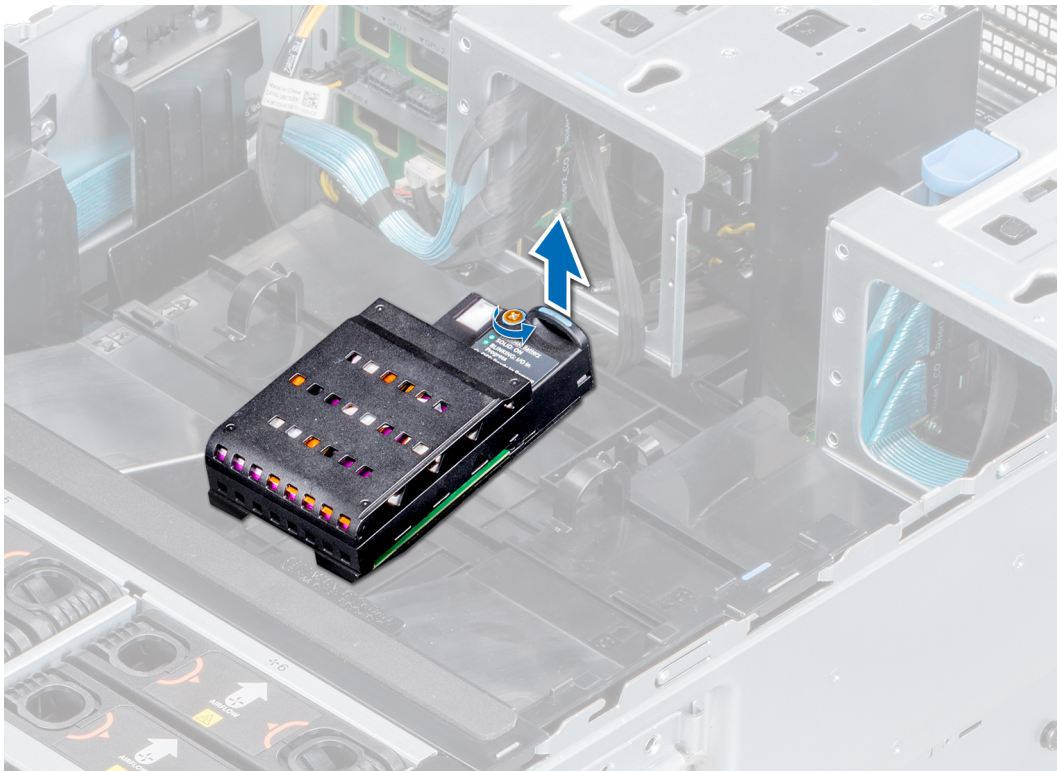

**Figure 53. Removing the NVDIMM-N battery from the air shroud**

### Next steps

1. [Replace the NVDIMM-N battery](#)

# Installing the NVDIMM-N battery

## Prerequisites

1. Follow the safety guidelines listed in [Safety instructions](#).

**CAUTION:** NVDIMM-N battery is not hot swappable. To prevent data loss and potential damage to your system, ensure that your system, LEDs on system, LEDs on NVDIMM-N and LEDs on NVDIMM-N battery are turned off before installing the NVDIMM-N battery.

**CAUTION:** To avoid damage to the battery connector, you must firmly support the connector while installing or removing a battery.

2. Follow the procedure listed in [Before working inside your system](#).
3. [Remove the support bar](#).
4. [Remove the air shroud A](#).

## Steps

1. Incline the NVDIMM-N battery at an angle and place the battery on the air shroud slot.
2. Using a Phillips #2 screwdriver, tighten the screw to secure the NVDIMM-N battery.
3. Connect the battery backup cable, and the NVDIMM connector cable to the NVDIMM-N battery.



Figure 54. Installing NVDIMM-N battery

## Next steps

1. [Replace the air shroud A](#).
2. [Replace the support bar](#).
3. [Follow the procedure listed in After working inside your system](#).

# Drive backplane

Depending on your system configuration, the drive backplanes supported in PowerEdge R940xa are listed here:

**Table 4. Supported backplane options for PowerEdge R940xa system.**

System	Supported backplane options
PowerEdge R940xa	2.5-inch (x24) SAS/SATA backplane
	2.5-inch (x24) backplane expander which supports 4 SAS/SATA/NVMe hard drives
	2.5-inch (x8) SAS/SATA backplane
	2.5-inch (x8) SAS/SATA lower backplane

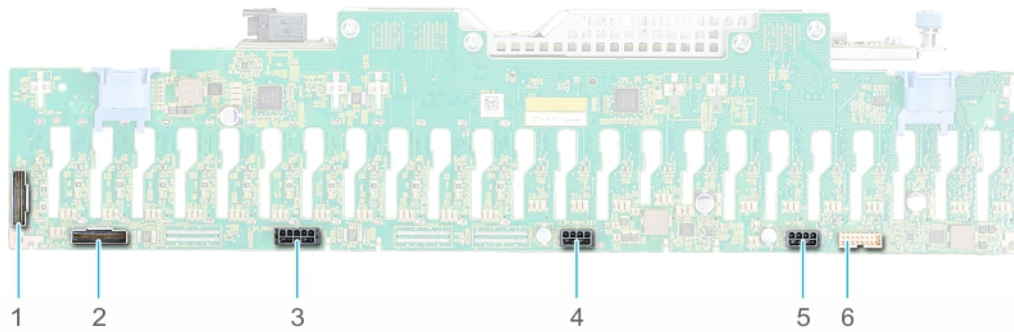

**Figure 55. 2.5-inch (x24) SAS/SATA backplane**

- 1. Slimline SAS cable connector
- 2. Slimline SAS cable connector
- 3. Power cable connector
- 4. Power cable connector
- 5. Power cable connector
- 6. Backplane signal connector

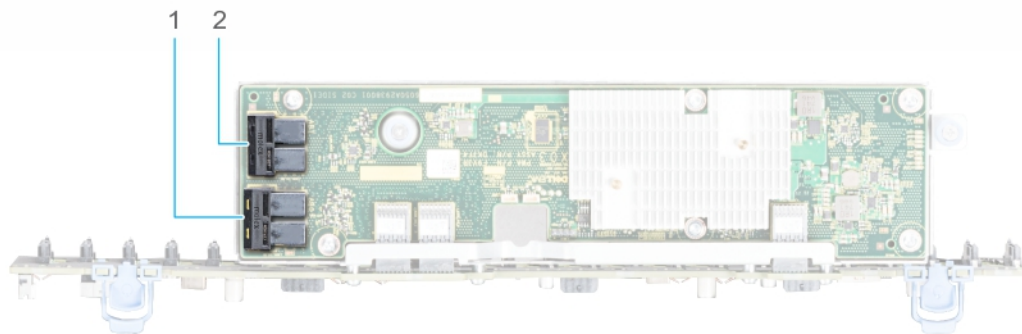

**Figure 56. 2.5-inch (x24) backplane expander**

- 1. Mini SAS hard drive AB 0
- 2. Mini SAS hard drive AB 1

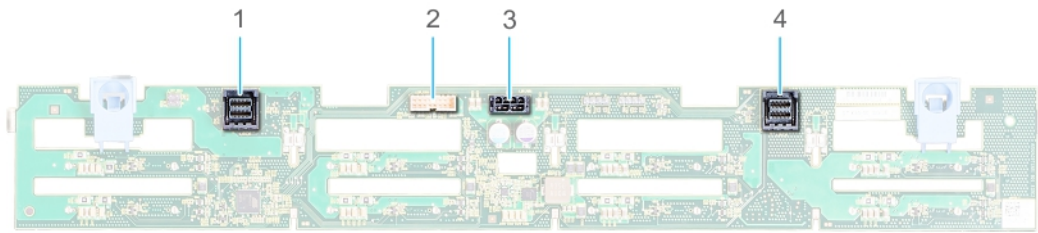

**Figure 57. 2.5-inch (x8) SAS/SATA backplane**

- |                            |                               |
|----------------------------|-------------------------------|
| 1. Mini SAS hard drive B 1 | 2. Backplane signal connector |
| 3. Power cable connector   | 4. Mini SAS hard drive A 1    |

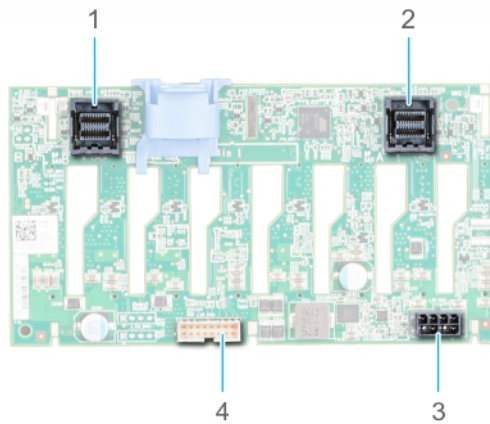

**Figure 58. 2.5-inch (x8) SAS/SATA lower backplane**

- |                            |                               |
|----------------------------|-------------------------------|
| 1. Mini SAS hard drive B 1 | 2. Mini SAS hard drive A 1    |
| 3. Power cable connector   | 4. Backplane signal connector |

## Removing the drive backplane

### Prerequisites

**CAUTION:** To prevent damage to the drives and backplane, remove the drives from the system before removing the backplane.

**CAUTION:** Note the number of each drive and temporarily label them before you remove the drive so that you can replace them in the same locations.

1. Follow the safety guidelines listed in [Safety instructions](#).
2. Follow the procedure listed in [Before working inside your system](#).
3. Disconnect the cables.
  - a. If applicable, disconnect all the slimline SAS cables from the system board.
  - b. If applicable, disconnect all the PERC cables from the adapter PERC cards.
4. [Remove the drives](#).
5. [Remove the support bar](#).
6. [Remove the air shrouds](#).
7. [Remove the cooling fan assembly](#).

### Steps

1. Loosen the two thumb screws on the backplane expander board.
2. Press and hold the blue release tabs, and lift the backplane expander board up to disengage the slots from the guides on the system.
3. Lift the backplane expander board out of the system.

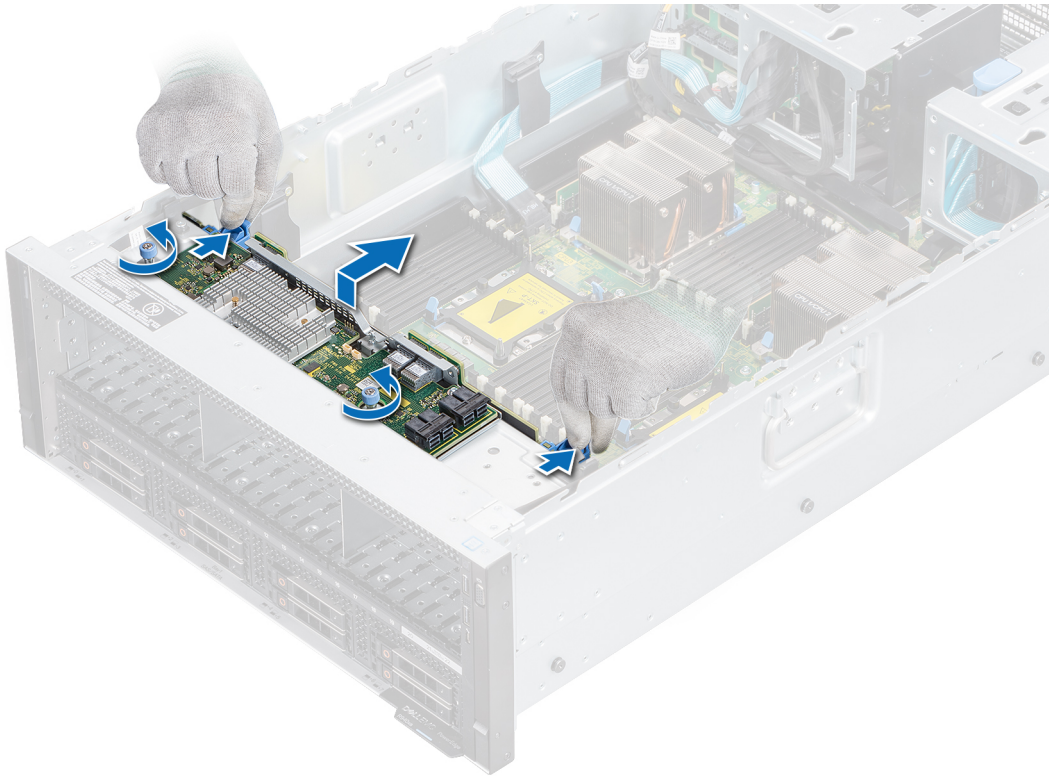

**Figure 59. Removing the backplane expander board**

4. Press and hold the blue release tabs, and lift the lower backplane to disengage the slots from the guides on the system.
5. Lift the lower backplane out of the system.

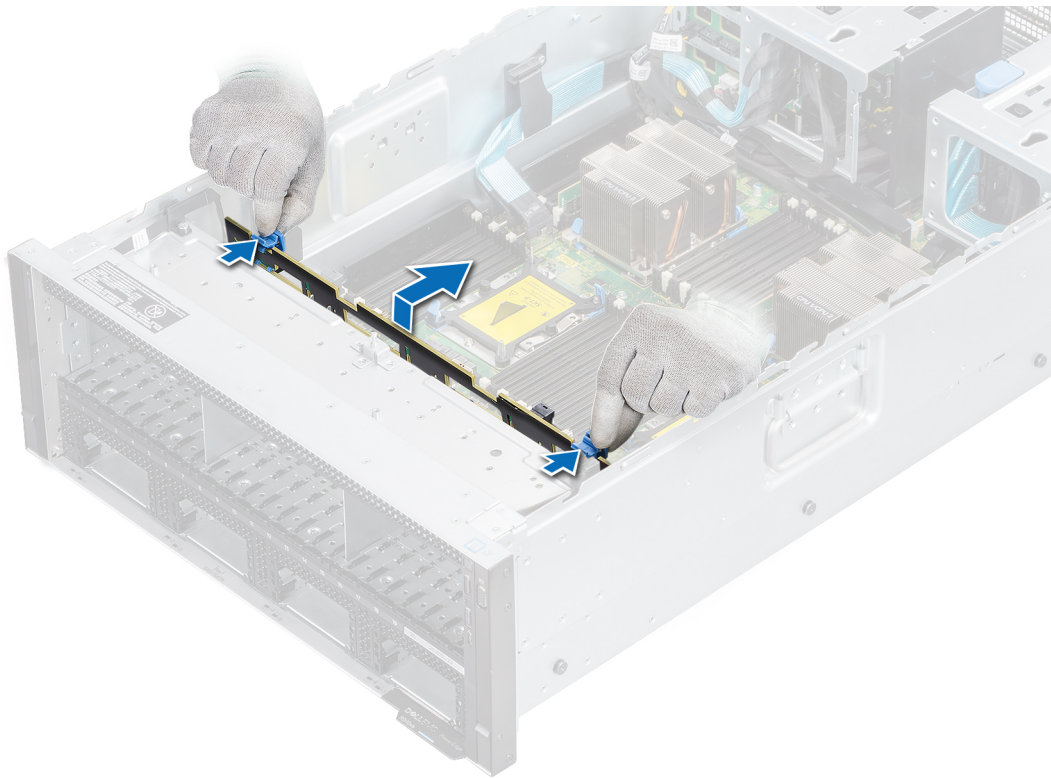

**Figure 60. Removing the lower backplane**

#### **Next steps**

1. [Replace the backplane.](#)

## **Installing the backplane**

#### **Prerequisites**

1. Follow the safety guidelines listed in [Safety instructions](#).
2. Follow the procedure listed in [Before working inside your system](#).
3. Disconnect the cables.
  - a. If applicable, disconnect the slimline SAS, I2C, and power cables to the backplane.
  - b. Disconnect the I2C and power cables to the system board.
4. [Remove the drives.](#)
5. [Remove the support bar.](#)
6. [Remove the air shrouds.](#)
7. [Remove the cooling fan assembly.](#)

#### **Steps**

1. Align the slots on the lower backplane with the guides on the system by holding the blue release tabs.
2. Press the lower backplane until the release tabs snap into place.

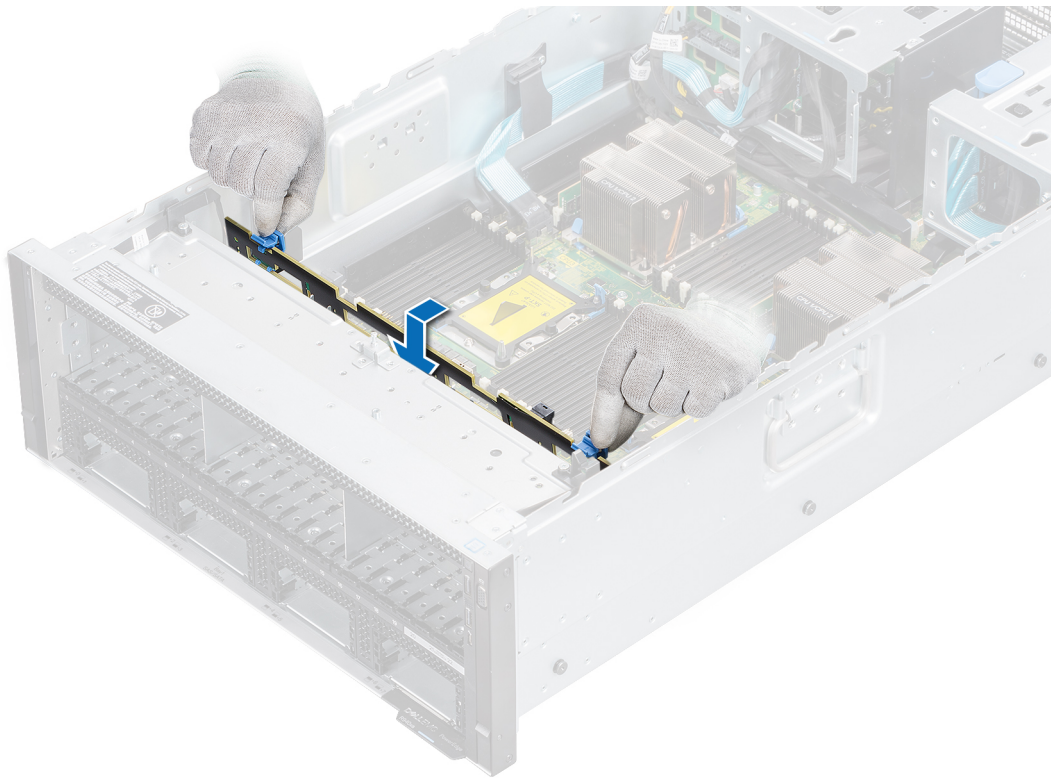

**Figure 61. Installing the lower backplane**

3. Align the slots on the backplane with the guides on the system by holding the blue release tabs.
4. Tighten the two thumb screws to secure the backplane expander board in place.

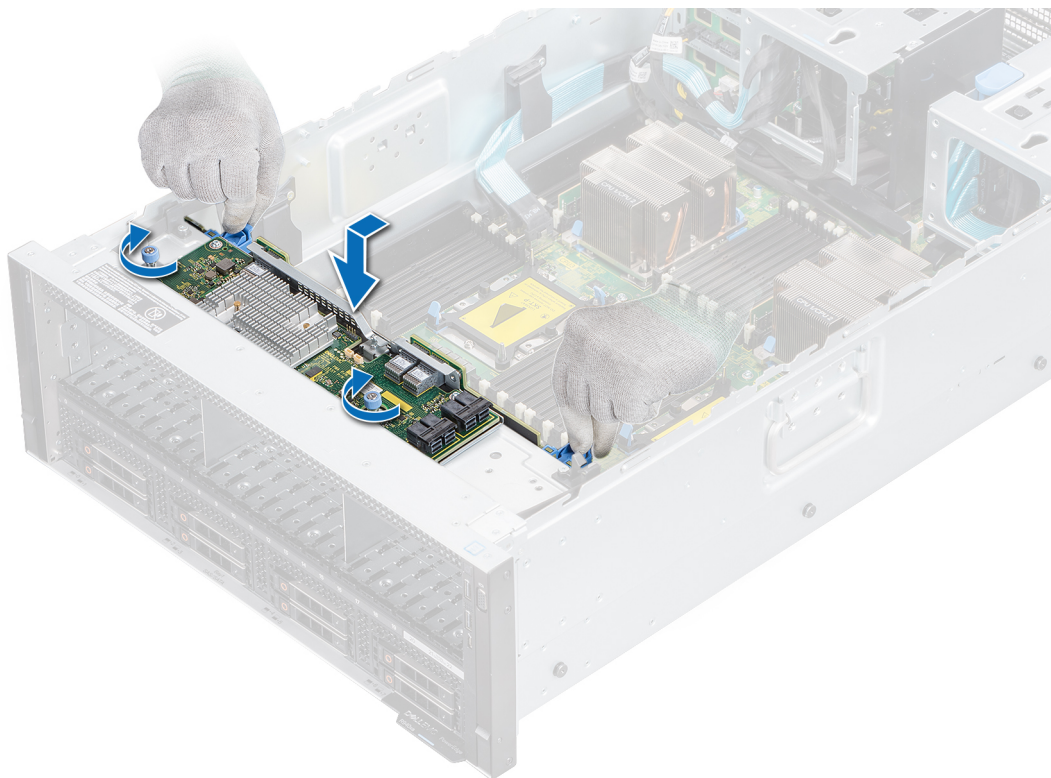

**Figure 62. Installing the backplane expander board**



### Next steps

1. Connect the cables.
  - a. If applicable, connect the slimline SAS, I2C, and power cables to the backplane.
  - b. Connect the I2C and power cables to the system board.
2. Replace the cooling fan assembly.
3. Replace the air shrouds.
4. Replace the support bar
5. Replace the drives.
6. Follow the procedure listed in [After working inside your system.](#)

## Cable routing

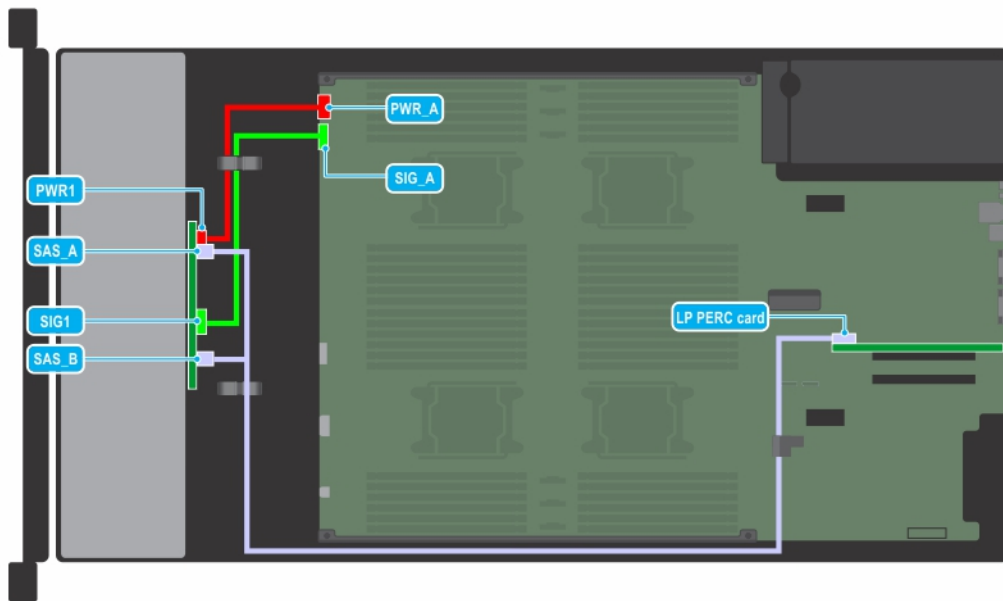

Figure 63. 8 x 2 CPU GPU

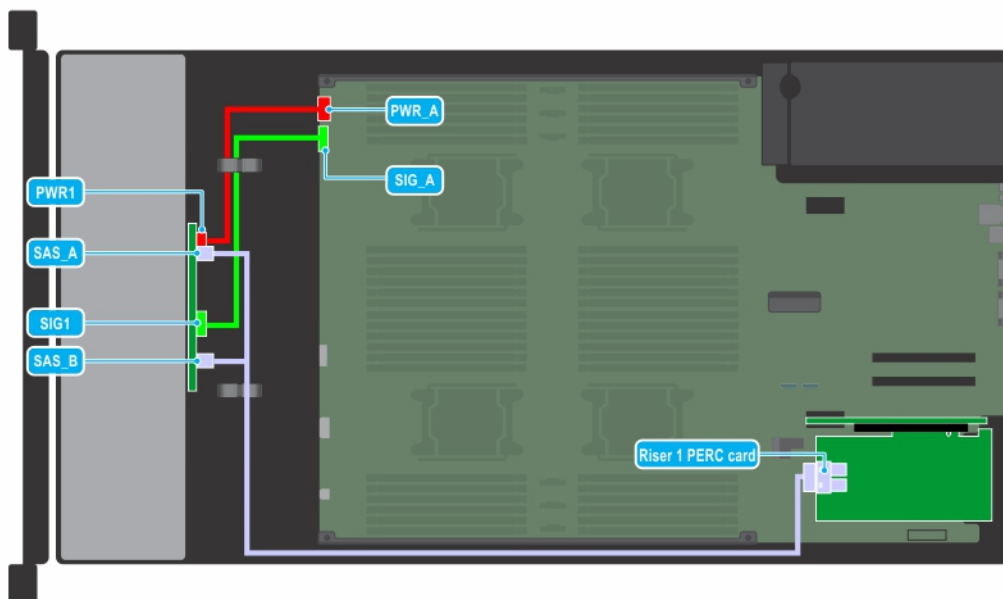

Figure 64. 8 x 2 CPU no GPU, 8 x 4 CPU no GPU without front NVMe, 8 x 4 CPU GPU without front NVMe

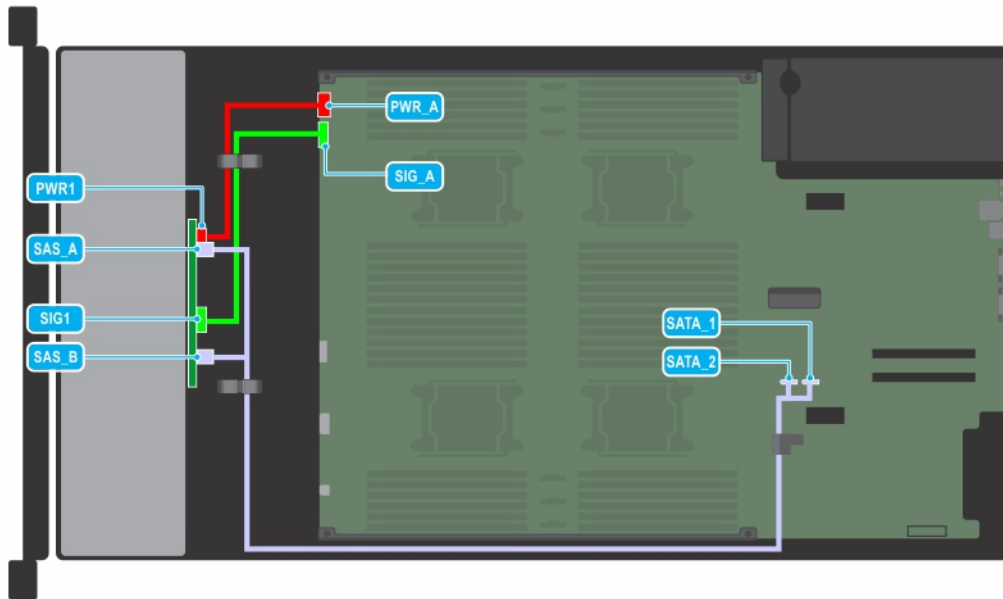

Figure 65. 8 X Chipset SATA

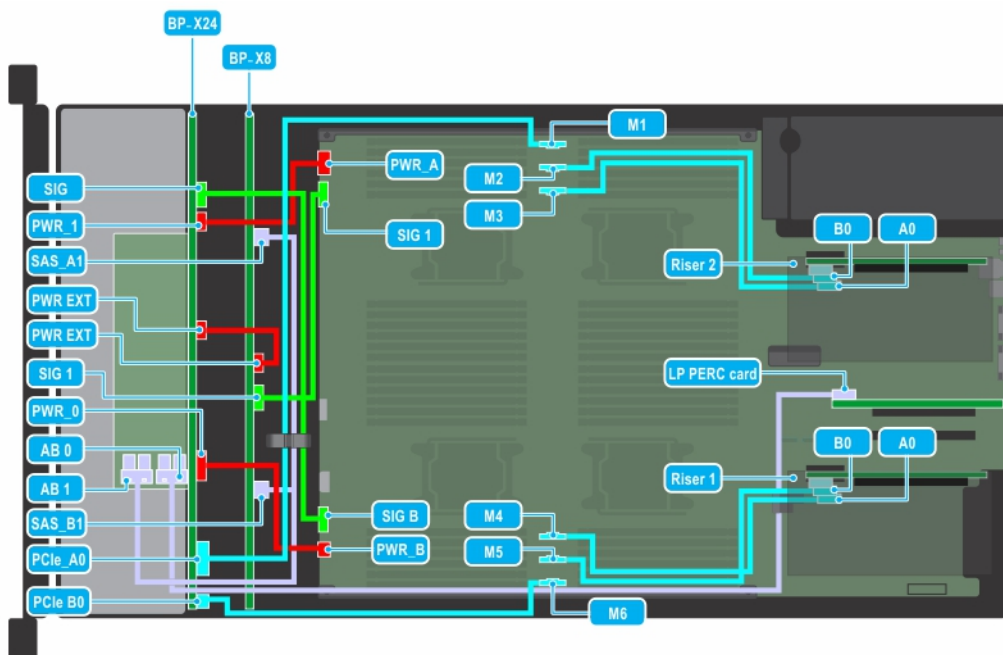

Figure 66. 32 x 4 P Single PERC/GPU/NVMe

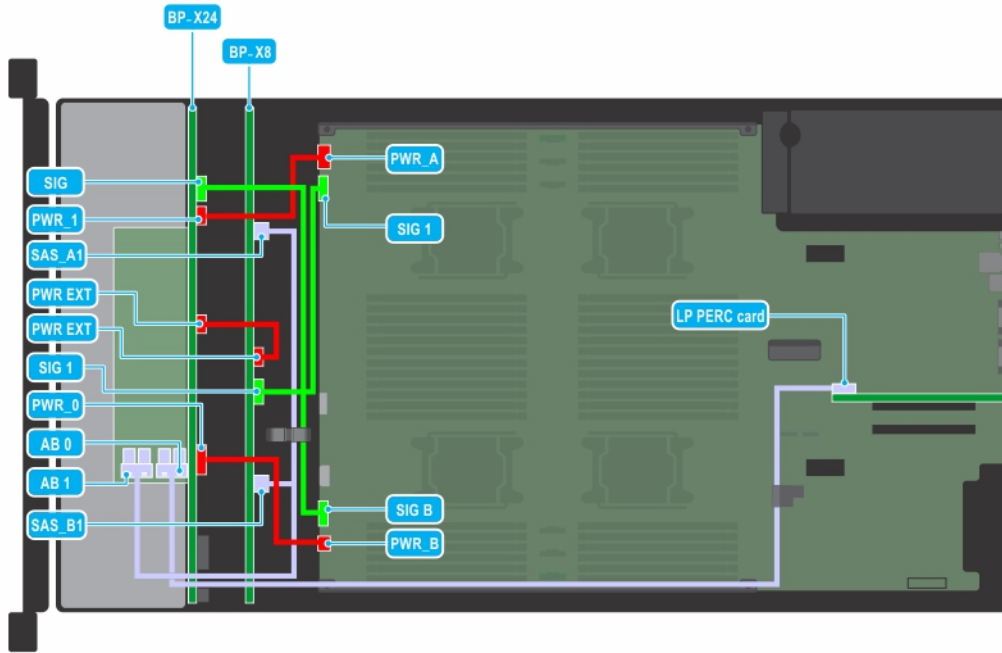

Figure 67. 32 x 2 P Single PERC/GPU/No-NVMe

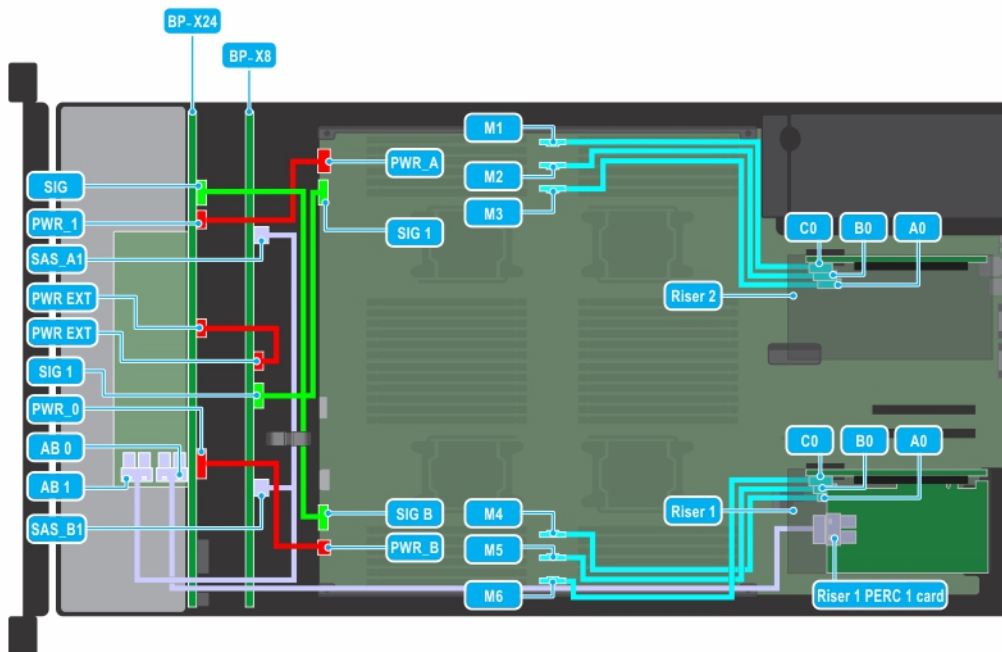

Figure 68. 32 x 4 P Single PERC/GPU/No-NVMe

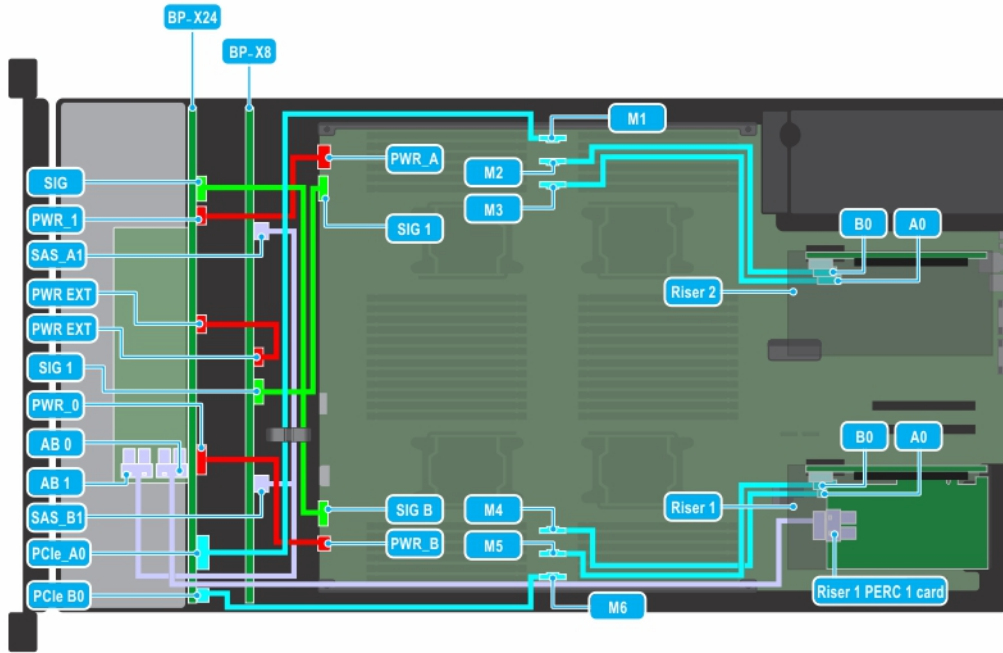

Figure 69. 32 x 4 P Single PERC/GPU/NVMe

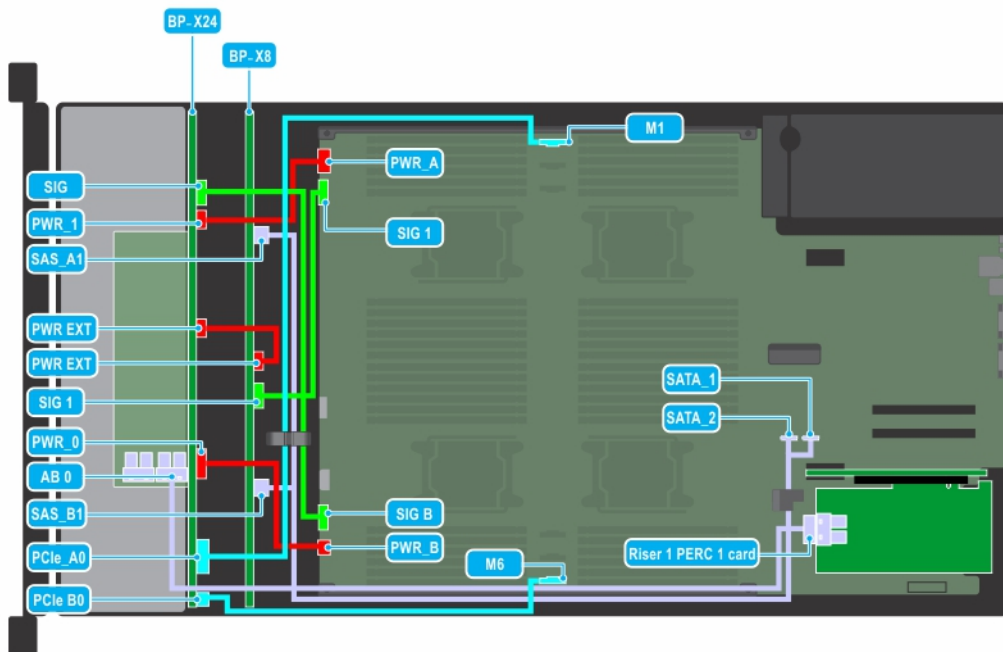
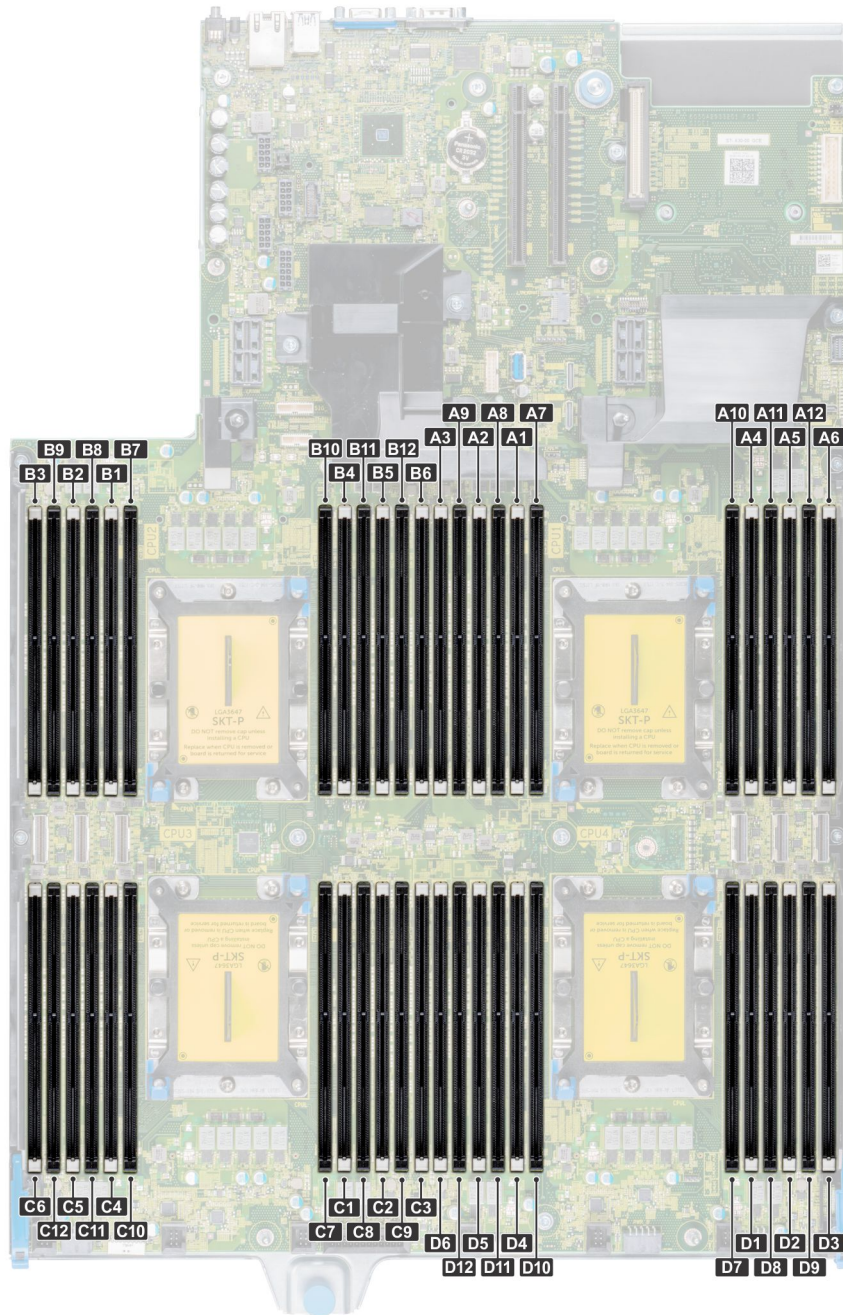

Figure 70. 32 x 2 P Single PERC/No-GPU/NVMe

## System memory

Your system contains 48 memory sockets split into four sets of 12 sockets, one set per processor. Each 12-socket set is organized into six channels. Six memory channels are allocated to each processor. In each channel, the release tabs of the first socket are marked white, and the second socket black.



**Figure 71. Memory socket locations**

Memory channels are organized as follows:

**Table 5. Memory channels**

Processor	Channel 0	Channel 1	Channel 2	Channel 3	Channel 4	Channel 5
Processor 1	Slots A1 and A7	Slots A2 and A8	Slots A3 and A9	Slots A4 and A10	Slots A5 and A11	Slots A6 and A12
Processor 2	Slots B1 and B7	Slots B2 and B8	Slots B3 and B9	Slots B4 and B10	Slots B5 and B11	Slots B6 and B12
Processor 3	Slots C1 and C7	Slots C2 and C8	Slots C3 and C9	Slots C4 and C10	Slots C5 and C11	Slots C6 and C12
Processor 4	Slots D1 and D7	Slots D2 and D8	Slots D3 and D9	Slots D4 and D10	Slots D5 and D11	Slots D6 and D12

## General memory module installation guidelines

To ensure optimal performance of your system, observe the following general guidelines when configuring your system memory. If your system's memory configurations fail to observe these guidelines, your system might not boot, stop responding during memory configuration, or operate with reduced memory.

The memory bus may operate at frequencies 2933 MT/s, 2666 MT/s, 2400 MT/s, or 2133 MT/s depending on the following factors:

- System profile selected (for example, Performance Optimized, or Custom [can be run at high speed or lower])
- Maximum supported DIMM speed of the processors. For memory frequency of 2933 MT/s, one DIMM per channel is supported.
- Maximum supported DIMM speed of the processors.
- Maximum supported speed of the DIMMs

 **NOTE:** MT/s indicates DIMM speed in MegaTransfers per second.

The system supports Flexible Memory Configuration, enabling the system to be configured and run in any valid chipset architectural configuration. The following are the recommended guidelines for installing memory modules:

- All DIMMs must be DDR4.
- RDIMMs and LRDIMMs must not be mixed.
- NVDIMMs and LRDIMMs must not be mixed.
- NVDIMMs and RDIMMs can be mixed.
- 64 GB LRDIMMs that are DDP (Dual Die Package) LRDIMMs must not be mixed with 128 GB LRDIMMs that are TSV (Through Silicon Via/3DS) LRDIMMs.
- x4 and x8 DRAM based memory modules can be mixed.
- Up to two RDIMMs can be populated per channel regardless of rank count.
- Up to two LRDIMMs can be populated per channel regardless of rank count.
- 256 GB does not support GPU configuration.
- A maximum of two different ranked DIMMs can be populated in a channel regardless of rank count.
- If memory modules with different speeds are installed, they will operate at the speed of the slowest installed memory module(s).
- Populate memory module sockets only if a processor is installed.
  - For single-processor systems, sockets A1 to A12 are available.
  - For dual-processor systems, sockets A1 to A12 and sockets B1 to B12 are available.
  - For quad-processor systems, sockets A1 to A12, sockets B1 to B12, sockets C1 to C12, and sockets D1 to D12 are available.
- Populate all the sockets with white release tabs first, followed by the black release tabs.
- When mixing memory modules with different capacities, populate the sockets with memory modules with the highest capacity first.
  -  **NOTE:** For example, if you want to mix 8 GB and 16 GB memory modules, populate 16 GB memory modules in the sockets with white release tabs and 8 GB memory modules in the sockets with black release tabs.
- Memory modules of different capacities can be mixed provided other memory population rules are followed.

 **NOTE:** For example, 8 GB and 16 GB memory modules can be mixed.

- In a dual-processor configuration, the memory configuration for each processor must be identical.

 **NOTE:** For example, if you populate socket A1 for processor 1, then populate socket B1 for processor 2, and so on.

- Mixing of more than two memory module capacities in one system is not supported.
- Unbalanced memory configurations will result in a performance loss so always populate memory channels identically with identical DIMMs for best performance.
- Populate six identical memory modules per processor (one DIMM per channel) at a time to maximize performance. DIMM population update for Performance Optimized mode with quantity of 4 and 8 DIMMs per processor.
- When the DIMM quantity is 4 per processor, the population is slot 1, 2, 4, 5.
- When the DIMM quantity is 8 per processor, the population is slot 1, 2, 4, 5, 7, 8, 10, 11.

## NVDIMM-N memory module installation guidelines

The following are the recommended guidelines for installing NVDIMM-N memory modules:

- Each system supports memory configurations with 1, 2, 4, 6, or 12 NVDIMM-Ns.
- Supported configurations have dual processors and a minimum of 12x RDIMMs.
- Maximum of 12 NVDIMM-Ns can be installed in a system.
- NVDIMM-Ns or RDIMMs must not be mixed with LRDIMMs.
- DDR4 NVDIMM-Ns must be populated only on the black release tabs on processor 1 and 2.
- For systems with four processors, RDIMMs populated on processor 3 and 4 must be identical to the number of RDIMMs populated on processor 1 and 2.
- All slots on configurations 3, 6, 9, and 12 can be used, but a maximum of 12 NVDIMM-Ns can be installed in a system.

**NOTE:** NVDIMM-N memory slots are not hot-pluggable.

For more information about the supported NVDIMM-N configurations, see the *NVDIMM-N User Guide* at [www.dell.com/poweredgemanuals](http://www.dell.com/poweredgemanuals).

**Table 6. Supported NVDIMM-N for dual processor configurations**

Configuration	Description	Memory population rules	
		RDIMMs	NVDIMM-N
Configuration 1	12x 16 GB RDIMMs, 1x NVDIMM-N	Processor1 {A1, 2, 3, 4, 5, 6} Processor2 {B1, 2, 3, 4, 5, 6}	Processor1 {A7}
Configuration 2	12x 32 GB RDIMMs, 1x NVDIMM-N	Same for all 12x RDIMM configurations. See Configuration 1.	Processor1 {A7}
Configuration 3	23x 32 GB RDIMMs, 1x NVDIMM-N	Processor1 {A1, 2, 3, 4, 5, 6, 7, 8, 9, 10, 11, 12} Processor2 {B1, 2, 3, 4, 5, 6, 7, 8, 9, 10, 11}	Processor2 {B12}
Configuration 4	12x 16 GB RDIMMs, 2x NVDIMM-Ns	Same for all 12x RDIMM configurations. See Configuration 1.	Processor1 {A7} Processor2 {B7}
Configuration 5	12x 32 GB RDIMMs, 2x NVDIMM-Ns	Same for all 12x RDIMM configurations. See Configuration 1.	Processor1 {A7} Processor2 {B7}
Configuration 6	22x 32 GB RDIMMs, 2x NVDIMM-Ns	Processor1 {A1, 2, 3, 4, 5, 6, 7, 8, 9, 10, 11} Processor2 {B1, 2, 3, 4, 5, 6, 7, 8, 9, 10, 11}	Processor1 {A12} Processor2 {B12}
Configuration 7	12x 16 GB RDIMMs, 4x NVDIMM-Ns	Same for all 12x RDIMM configurations. See Configuration 1.	Processor1 {A7, A8} Processor2 {B7, B8}
Configuration 8	22x 32 GB RDIMMs, 4x NVDIMM-Ns	Same for all 12x RDIMM configurations. See Configuration 1.	Processor1 {A7, A8} Processor2 {B7, B8}
Configuration 9	20x 32 GB RDIMMs, 4x NVDIMM-Ns	Processor1 {A1, 2, 3, 4, 5, 6, 7, 8, 9, 10} Processor2 {B1, 2, 3, 4, 5, 6, 7, 8, 9, 10}	Processor1 {A11, 12} Processor2 {B11, 12}
Configuration 10	12x 16 GB RDIMMs, 6x NVDIMM-Ns	Same for all 12x RDIMM configurations. See Configuration 1.	Processor1 {A7, 8, 9} Processor2 {B7, 8, 9}

**Table 6. Supported NVDIMM-N for dual processor configurations (continued)**

Configuration	Description	Memory population rules	
		RDIMMs	NVDIMM-N
Configuration 11	12x 32 GB RDIMMs, 6x NVDIMM-Ns	Same for all 12x RDIMM configurations. See Configuration 1.	Processor1 {A7, 8, 9} Processor2 {B7, 8, 9}
Configuration 12	18x 32 GB RDIMMs, 6x NVDIMM-Ns	Processor1 {1, 2, 3, 4, 5, 6, 7, 8, 9} Processor2 {1, 2, 3, 4, 5, 6, 7, 8, 9}	Processor1 {A10, 11, 12} Processor2 {B10, 11, 12}
Configuration 13	12x 16 GB RDIMMs, 12x NVDIMM-Ns	Same for all 12x RDIMM configurations. See Configuration 1.	Processor1 {A7, 8, 9, 10, 11, 12} Processor2 {B7, 8, 9, 10, 11, 12}
Configuration 14	12x 32 GB RDIMMs, 12x NVDIMM-Ns	Same for all 12x RDIMM configurations. See Configuration 1.	Processor1 {A7, 8, 9, 10, 11, 12} Processor2 {B7, 8, 9, 10, 11, 12}

**Table 7. Supported NVDIMM-N for quad processor configurations**

Configuration	Description	Memory population rules	
		RDIMMs	NVDIMM-N
Configuration 1	24x 16 GB RDIMMs, 1x NVDIMM-N	Processor1 {A1, 2, 3, 4, 5, 6}, Processor2 {B1, 2, 3, 4, 5, 6}, Processor3 {C1, 2, 3, 4, 5, 6} Processor4 {D1, 2, 3, 4, 5, 6}	Processor1 {A7}
Configuration 2	24x 32 GB RDIMMs, 1x NVDIMM-N	Same for all 24x RDIMM configurations. See Configuration 1.	Processor1 {A7}
Configuration 3	47x 32 GB RDIMMs, 1x NVDIMM-N	Processor1 {A1, 2, 3, 4, 5, 6, 7, 8, 9, 10, 11, 12} , Processor2 {B1, 2, 3, 4, 5, 6, 7, 8, 9, 10, 11} , Processor3 {C1, 2, 3, 4, 5, 6, 7, 8, 9, 10, 11, 12} Processor 4 {D1, 2, 3, 4, 5, 6, 7, 8, 9, 10, 11, 12}	Processor2 {B12}
Configuration 4	24x 16 GB RDIMMs, 2x NVDIMM-Ns	Processor1 {A1, 2, 3, 4, 5, 6}, Processor2 {B1, 2, 3, 4, 5, 6} Processor3 {C1, 2, 3, 4, 5, 6} Processor4 {D1, 2, 3, 4, 5, 6}	Processor1 {A7}, Processor2 {B7}
Configuration 5	24x 32 GB RDIMMs, 2x NVDIMM-Ns	Processor1 {A1, 2, 3, 4, 5, 6}, Processor2 {B1, 2, 3, 4, 5, 6}, Processor3 {C1, 2, 3, 4, 5, 6} Processor4 {D1, 2, 3, 4, 5, 6}	Processor1 {A7}, Processor2 {B7}
Configuration 6	46x 32 GB RDIMMs, 2x NVDIMM-Ns	Processor1 {A1, 2, 3, 4, 5, 6, 7, 8, 9, 10, 11}, Processor2 {B1, 2, 3, 4, 5, 6,	Processor1 {A12}, Processor2 {B12}



**Table 7. Supported NVDIMM-N for quad processor configurations (continued)**

Configuration	Description	Memory population rules	
		RDIMMs	NVDIMM-N
		7, 8, 9, 10, 11} , Processor3 {C1, 2, 3, 4, 5, 6, 7, 8, 9, 10, 11, 12} Processor 4 {D1, 2, 3, 4, 5, 6, 7, 8, 9, 10, 11, 12}	
Configuration 7	24x 16 GB RDIMMs, 4x NVDIMM-Ns	Processor1 {A1, 2, 3, 4, 5, 6}, Processor2 {B1, 2, 3, 4, 5, 6}, Processor3 {C1, 2, 3, 4, 5, 6} Processor4 {D1, 2, 3, 4, 5, 6}	Processor1 {A7,8}, Processor2 {B7,8}
Configuration 8	24x 32 GB RDIMMs, 4x NVDIMMs	Processor1 {A1, 2, 3, 4, 5, 6}, Processor2 {B1, 2, 3, 4, 5, 6}, Processor3 {C1, 2, 3, 4, 5, 6} Processor4 {D1, 2, 3, 4, 5, 6}	Processor1 {A7,8}, Processor2 {B7,8}
Configuration 9	44x 32 GB RDIMMs, 4x NVDIMM-Ns	Processor1 {A1, 2, 3, 4, 5, 6, 7, 8, 9, 10}, Processor2 {B1, 2, 3, 4, 5, 6, 7, 8, 9, 10}, Processor3 {C1, 2, 3, 4, 5, 6, 7, 8, 9, 10, 11, 12} Processor4 {D1, 2, 3, 4, 5, 6, 7, 8, 9, 10, 11, 12}	Processor1 {A11, 12}, Processor2 {B11, 12}
Configuration 10	24x 16 GB RDIMMs, 6x NVDIMM-Ns	Processor1 {A1, 2, 3, 4, 5, 6}, Processor2 {B1, 2, 3, 4, 5, 6} Processor3 {C1, 2, 3, 4, 5, 6} Processor4 {D1, 2, 3, 4, 5, 6}	Processor1 {A7, 8, 9} Processor2 {B7, 8, 9}
Configuration 11	24x 32 GB RDIMMs, 6x NVDIMM-Ns	Processor1 {A1, 2, 3, 4, 5, 6}, Processor2 {B1, 2, 3, 4, 5, 6}, Processor3 {C1, 2, 3, 4, 5, 6} Processor4 {D1, 2, 3, 4, 5, 6}	Processor1 {A7, 8, 9} Processor2 {B7, 8, 9}
Configuration 12	42x 32 GB RDIMMs, 6x NVDIMM-Ns	Processor1 {A1, 2, 3, 4, 5, 6, 7, 8, 9}, Processor2 {B1, 2, 3, 4, 5, 6, 7, 8, 9} Processor3 {C1, 2, 3, 4, 5, 6, 7, 8, 9, 10, 11, 12} Processor4 {D1, 2, 3, 4, 5, 6, 7, 8, 9, 10, 11, 12}	Processor1 {A10,11,12} Processor2 {B10, 11, 12}
Configuration 13	24x 16 GB RDIMMs, 12x NVDIMM-Ns	Processor1 {A1, 2, 3, 4, 5, 6}, Processor2 {B1, 2, 3, 4, 5, 6}, Processor3 {C1, 2, 3, 4, 5, 6} Processor4 {D1, 2, 3, 4, 5, 6}	Processor1 {A7, 8, 9, 10, 11, 12}, Processor2 {B7, 8, 9, 10, 11, 12}
Configuration 14	24x 32 GB RDIMMs, 12x NVDIMM-Ns	Processor1 {A1, 2, 3, 4, 5, 6}, Processor2 {B1, 2, 3, 4, 5, 6}, Processor3 {C1, 2, 3, 4, 5, 6} Processor4 {D1, 2, 3, 4, 5, 6}	Processor1 {A7, 8, 9, 10, 11, 12}, Processor2 {B7, 8, 9, 10, 11, 12}

**Table 7. Supported NVDIMM-N for quad processor configurations (continued)**

Configuration	Description	Memory population rules	
		RDIMMs	NVDIMM-N
Configuration 15	36x 32 GB RDIMMs, 12x NVDIMM-Ns	Processor1 {A1, 2, 3, 4, 5, 6}, Processor2 {B1, 2, 3, 4, 5, 6}, Processor3 {C1, 2, 3, 4, 5, 6, 7, 8, 9, 10, 11, 12} Processor 4 {D1, 2, 3, 4, 5, 6, 7, 8, 9, 10, 11, 12}	Processor1 {A7, 8, 9, 10, 11, 12}, Processor2 {B7, 8, 9, 10, 11, 12}

## PMem installation guidelines

The following are the recommended guidelines for installing data center persistent memory module (PMem) memory modules:

- Each system supports maximum of one PMem memory module per channel.
- **i** **NOTE:** If two different PMem capacities are mixed, an F1/F2 warning is displayed as the configuration is not supported.
- PMem can be mixed with RDIMM, LRDIMM, and 3DS LRDIMM.
- Mixing of DDR4 DIMM types (RDIMM, LRDIMM, and 3DS LRDIMM), within channels, for Integrated Memory Controller (iMC), or across sockets are not supported.
- Mixing of PMem operating modes (App Direct, Memory Mode) is not supported.
- If only one DIMM is populated on a channel, it should always go to the first slot in that channel (white slot).
- If a PMem and a DDR4 DIMM are populated on the same channel, always plug PMem on second slot (black slot).
- If the PMem is configured in Memory Mode, the recommended DDR4 to PMem capacity ratio is 1:4 to 1:16 per iMC.
- PMems' cannot be mixed with other PMems capacities or NVDIMMs.
- Mixing different capacities of RDIMMs and LRDIMMs are not allowed when PMem is installed.
- PMems of different capacities are not allowed.
- PMem does not support GPU configurations

For more information about the supported PMem configurations, see the *Dell EMC PMem User 's Guide* at [https://www.dell.com/support/home/products/server\\_int/server\\_int\\_poweredge](https://www.dell.com/support/home/products/server_int/server_int_poweredge).

**Table 8. 2 socket PMem configurations**

No. of CPUs in the Server	PMem Population	DRAM Population	DRAM Capacity (GB)	PMem Capacity (GB)	Operating system Memory in Memory Mode (GB)	Total Memory (GB)	Total Memory per CPU (GB)	Ratio DRAM to Optane Memory	Requires an M or L CPU	Supported in App Direct Mode	Supported in Memory Mode
2	128 GB x 1	16 GB x 12	192	128	N/A	320	160	1 : 0.7	No	Yes	No
2	128 GB x 2	16 GB x 12	192	256	N/A	448	224	1 : 1.3	No	Yes	No
2	128 GB x 4	16 GB x 8	128	512	512	640	320	1 : 4	No	Yes	Yes
2	128 GB x 4	16 GB x 12	192	512	N/A	704	352	1 : 2.7	No	Yes	No
2	128 GB x 8	16 GB x 12	192	1,024	1,024	1,216	608	1 : 5.3	No	Yes	Yes
2	128 GB x 12	16 GB x 12	192	1,536	1,536	1,728	864	1 : 8	No	Yes	Yes
2	128 GB x 1	32 GB x 12	384	128	N/A	512	256	1 : 0.3	No	Yes	No
2	128 GB x 2	32 GB x 12	384	256	N/A	640	320	1 : 0.7	No	Yes	No

**Table 8. 2 socket PMem configurations (continued)**

No. of CPUs in the Server	PMem Population	DRAM Population	DRAM Capacity (GB)	PMem Capacity (GB)	Operating system Memory in Memory Mode (GB)	Total Memory (GB)	Total Memory per CPU (GB)	Ratio DRAM to Optane Memory	Requires an M or L CPU	Supported in App Direct Mode	Supported in Memory Mode
2	128 GB x 4	32 GB x 12	384	512	N/A	896	448	1 : 1.3	No	Yes	No
2	128 GB x 8	32 GB x 12	384	1,024	N/A	1,408	704	1 : 2.7	No	Yes	No
2	128 GB x 12	32 GB x 12	384	1,536	1,536	1,920	960	1 : 4	No	Yes	Yes
2	128 GB x 4	64 GB x 12	768	512	N/A	1,280	640	1 : 0.7	No	Yes	No
2	128 GB x 8	64 GB x 12	768	1,024	N/A	1,792	896	1 : 1.3	No	Yes	No
2	128 GB x 12	64 GB x 12	768	1,536	N/A	2,304	1,152	1 : 2	L SKU	Yes	No
2	128 GB x 12	128 GB x 12	1,536	1,536	N/A	3,072	1,536	1 : 1	L SKU	Yes	No
2	512 GB x 8	32 GB x 12	384	4,096	4,096	4,480	2,240	1 : 10.7	L SKU	Yes	Yes
2	512 GB x 12	32 GB x 12	384	6,144	6,144	6,528	3,264	1 : 16	L SKU	Yes	Yes
2	512 GB x 8	64 GB x 12	768	4,096	4,096	4,864	2,432	1 : 5.3	L SKU	Yes	Yes
2	512 GB x 12	64 GB x 12	768	6,144	6,144	6,912	3,456	1 : 8	L SKU	Yes	Yes
2	512 GB x 12	128 GB x 12	1,536	6,144	6,144	7,680	3,840	1 : 4	L SKU	Yes	Yes
2	256 GB x 8	16 GB x 12	192	2,048	2,048	2,240	1,120	1 : 10.7	L SKU	Yes	Yes
2	256 GB x 8	32 GB x 12	384	2,048	2,048	2,432	1,216	1 : 5.3	L SKU	Yes	Yes
2	256 GB x 12	32 GB x 12	384	3,072	3,072	3,456	1,728	1 : 8	L SKU	Yes	Yes
2	256 GB x 8	64 GB x 12	768	2,048	N/A	2,816	1,408	1 : 2.7	L SKU	Yes	No
2	256 GB x 12	64 GB x 12	768	3,072	3,072	3,840	1,920	1 : 4	L SKU	Yes	Yes
2	256 GB x 12	128 GB x 12	1,536	3,072	N/A	4,608	2,304	1 : 2	L SKU	Yes	No

**Table 9. 4 socket PMem configurations**

No. of CPUs in the Server	PMem Populati onn	DRAM Populati on	DRAM Capacit y (GB)	PMem Capacit y (GB)	Operati ng system Memory in Memory Mode (GB)	Total Memory (GB)	Total Memory per CPU (GB)	Ratio DRAM to Optane Memory	Require s an M or L CPU	Support ed in App Direct Mode	Support ed in Memory Mode
4	128 GB x 16	16 GB x 24	384	2,048	2,048	2,432	608	1 : 5.3	No	Yes	Yes
4	128 GB x 24	16 GB x 24	384	3,072	3,072	3,456	864	1 : 8	No	Yes	Yes
4	128 GB x 16	32 GB x 24	768	2,048	N/A	2,816	704	1 : 2.7	No	Yes	No
4	128 GB x 24	32 GB x 24	768	3,072	3,072	3,840	960	1 : 4	No	Yes	Yes
4	128 GB x 24	64 GB x 24	1,536	3,072	N/A	4,608	1,152	1 : 2	L SKU	Yes	No
4	128 GB x 24	128 GB x 24	3,072	3,072	N/A	6,144	1,536	1 : 1	L SKU	Yes	No
4	512 GB x 16	32 GB x 24	768	8,192	8,192	8,960	2,240	1 : 10.7	L SKU	Yes	Yes
4	512 GB x 24	32 GB x 24	768	12,288	12,288	13,056	3,264	1 : 16	L SKU	Yes	Yes
4	512 GB x 16	64 GB x 24	1,536	8,192	8,192	9,728	2,432	1 : 5.3	L SKU	Yes	Yes
4	512 GB x 24	64 GB x 24	1,536	12,288	12,288	13,824	3,456	1 : 8	L SKU	Yes	Yes
4	512 GB x 24	128 GB x 24	3,072	12,288	12,288	15,360	3,840	1 : 4	L SKU	Yes	Yes
4	256 GB x 16	16 GB x 24	384	4,096	4,096	4,480	1,120	1 : 10.7	L SKU	Yes	Yes
4	256 GB x 24	16 GB x 24	384	6,144	6,144	6,528	1,632	1 : 16	L SKU	Yes	Yes
4	256 GB x 16	32 GB x 24	768	4,096	4,096	4,864	1,216	1 : 5.3	L SKU	Yes	Yes
4	256 GB x 24	32 GB x 24	768	6,144	6,144	6,912	1,728	1 : 8	L SKU	Yes	Yes
4	256 GB x 16	64 GB x 24	1,536	4,096	N/A	5,632	1,408	1 : 2.7	L SKU	Yes	No
4	256 GB x 24	64 GB x 24	1,536	6,144	6,144	7,680	1,920	1 : 4	L SKU	Yes	Yes
4	256 GB x 24	128 GB x 24	3,072	6,144	N/A	9,216	2,304	1 : 2	L SKU	Yes	No

**NOTE:**

PMem is supported on systems with 1600W and 2400 W PSU configuration.

Max ambient Temperature is 25C.

Max PMem TDP is 15 W.

PMem supports up to 4 NVMe hard drive (2.5-inches x 32 backplane).

PMem does not support GPU configuration.

Two CPU configurations with 2.5-inches x 32 backplane, does not support 205 W/200 W and 6244/6246/6240Y CPU.

**Table 10. PMem Thermal Restrictions**

PMem Support	V2 Air-shroud	V1 Air-shroud
<b>8x 2.5-inch SAS/SATA</b>	30C ambient temperature support, 25C ambient temperature with 256GB LRDIMMs	25C ambient temperature support, not supported with 256GB LRDIMM
<b>24x 2.5-inch SAS/SATA</b>	30C ambient temperature support, not supported with 256GB LRDIMM	25C ambient temperature support, not supported with 256GB LRDIMM
<b>32x 2.5-inch SAS/SATA or mixed NVMe</b>	30C ambient temperature support, not supported with 256GB LRDIMM	25C ambient temperature support, not supported with 256GB LRDIMM

 **NOTE:** PMem does not support GPU configuration.

## Mode-specific guidelines

The configurations allowed depend on the memory mode selected in the System BIOS.

**Table 11. Memory operating modes**

Memory Operating Mode	Description
<b>Optimizer Mode</b>	The <b>Optimizer Mode</b> if enabled, the DRAM controllers operate independently in the 64-bit mode and provide optimized memory performance.  <b>NOTE:</b> PMem supports only Optimizer mode.
<b>Mirror Mode</b>	The <b>Mirror Mode</b> if enabled, the system maintains two identical copies of data in memory, and the total available system memory is one half of the total installed physical memory. Half of the installed memory is used to mirror the active memory modules. This feature provides maximum reliability and enables the system to continue running even during a catastrophic memory failure by switching over to the mirrored copy. The installation guidelines to enable Mirror Mode require that the memory modules be identical in size, speed, and technology, and they must be populated in sets of 6 per processor.
<b>Single Rank Spare Mode</b>	<b>Single Rank Spare Mode</b> allocates one rank per channel as a spare. If excessive correctable errors occur in a rank or channel, while the operating system is running, they are moved to the spare area to prevent errors from causing an uncorrectable failure. Requires two or more ranks to be populated in each channel.
<b>Multi Rank Spare Mode</b>	<b>Multi Rank Spare Mode</b> allocates two ranks per channel as a spare. If excessive correctable errors occur in a rank or channel, while the operating system is running, they are moved to the spare area to prevent errors from causing an uncorrectable failure. Requires three or more ranks to be populated in each channel.  With single rank memory sparing enabled, the system memory available to the operating system is reduced by one rank per channel.  For example, in a dual-processor configuration with 24x 16 GB dual-rank memory modules, the available system memory is: $\frac{3}{4}$ (ranks/channel) $\times$ 24 (memory modules) $\times$ 16 GB = 288 GB, and not 24 (memory modules) $\times$ 16 GB = 384 GB. For multi rank sparing, the multiplier changes to $\frac{1}{2}$ (ranks/channel).

**Table 11. Memory operating modes (continued)**

Memory Operating Mode	Description
	<p><b>i</b> <b>NOTE:</b> To use memory sparing, this feature must be enabled in the BIOS menu of System Setup.</p> <p><b>i</b> <b>NOTE:</b> Memory sparing does not offer protection against a multi-bit uncorrectable error.</p>
<b>Dell Fault Resilient Mode</b>	<p>The <b>Dell Fault Resilient Mode</b> if enabled, the BIOS creates an area of memory that is fault resilient. This mode can be used by an OS that supports the feature to load critical applications or enables the OS kernel to maximize system availability.</p> <p><b>i</b> <b>NOTE:</b> This feature is only supported in Gold and Platinum Intel processors.</p> <p><b>i</b> <b>NOTE:</b> Memory configuration has to be of same size DIMM, speed, and rank.</p>

## Optimizer Mode

This mode supports Single Device Data Correction (SDDC) only for memory modules that use x4 device width. It does not impose any specific slot population requirements.

- Dual processor: Populate the slots in round robin sequence starting with processor 1.
  - i** **NOTE:** Processor 1 and processor 2 population should match.
- Quad processor: Populate the slots in round robin sequence starting with processor 1.
  - i** **NOTE:** Processor 1, processor 2, processor 3, and processor 4 population should match.

**Table 12. Memory population rules**

Processor	Configuration	Memory population	Memory population information
Dual processor (Start with processor1. processor1 and processor 2 population should match)	Optimized (Independent channel) population order	A{1}, B{1}, A{2}, B{2}, A{3}, B{3}, A{4}, B{4}, A{5}, B{5}, A{6}, B{6}	<p>Odd number of DIMM population per processor is allowed.</p> <p><b>i</b> <b>NOTE:</b> Odd number of DIMMs will result in unbalanced memory configurations, which in turn will result in performance loss. It is recommended to populate all memory channels identically with identical DIMMs for best performance.</p> <p><b>i</b> <b>NOTE:</b> For best performance, 6 DIMMs or 12 DIMMs per processor is recommended.</p> <p>Optimizer population order is not traditional for 8 and 16 DIMMs installations for dual processor.</p> <ul style="list-style-type: none"> <li>• For 8 DIMMs: A1, A2, A4, A5, B1, B2, B4, B5</li> <li>• For 16 DIMMs: A1, A2, A4, A5, A7, A8, A10, A11 B1, B2, B4, B5, B7, B8, B10, B11</li> </ul>
	Mirroring population order	A{1, 2, 3, 4, 5, 6}, B{1, 2, 3, 4, 5, 6}, A{7, 8, 9, 10, 11, 12}, B{7, 8, 9, 10, 11, 12}	Mirroring is supported with 6 or 12 DIMMs per processor.
	Single rank sparing population order	A{1}, B{1}, A{2}, B{2}, A{3}, B{3}, A{4}, B{4}, A{5}, B{5}, A{6}, B{6}	<ul style="list-style-type: none"> <li>• DIMMs must be populated in the order specified.</li> <li>• Requires two ranks or more per channel.</li> </ul>

**Table 12. Memory population rules (continued)**

Processor	Configuration	Memory population	Memory population information
	Multi rank sparing population order	A{1}, B{1}, A{2}, B{2}, A{3}, B{3}, A{4}, B{4}, A{5}, B{5}, A{6}, B{6}	<ul style="list-style-type: none"> <li>DIMMs must be populated in the order specified.</li> <li>Requires three ranks or more per channel.</li> </ul>
	Fault resilient population order	A{1, 2, 3, 4, 5, 6}, B{1, 2, 3, 4, 5, 6}, A{7, 8, 9, 10, 11, 12}, B{7, 8, 9, 10, 11, 12}	Supported with 6 or 12 DIMMs per processor.
Quad processor (Starting with processor 1, and processor 1, processor 2, processor 3, and processor 4 population should match)	Optimized population order (Independent channel)	A{1}, B{1}, C{1}, D{1}, A{2}, B{2}, C{2}, D{2}, A{3}, B{3}, C{3}, D{3}, A{4}, B{4}, C{4}, D{4}	<p>Odd number of DIMM population per processor is allowed.</p> <p><b>i NOTE:</b> Odd number of DIMMs will result in unbalanced memory configurations, which in turn will result in performance loss. It is recommended to populate all memory channels identically with identical DIMMs for best performance.</p> <p><b>i NOTE:</b> For best performance, 6 DIMMs or 12 DIMMs per processor is recommended.</p> <p>Optimizer population order is not traditional for 16 and 32 DIMMs installations for dual processor.</p> <ul style="list-style-type: none"> <li>For 16 DIMMs: A1, A2, A4, A5, B1, B2, B4, B5, C1, C2, C4, C5, D1, D2, D4, D5</li> <li>For 32 DIMMs: A1, A2, A4, A5, A7, A8, A10, A11, B1, B2, B4, B5, B7, B8, B10, B11, C1, C2, C4, C5, C7, C8, C10, C11, D1, D2, D4, D5, D7, D8, D10, D11</li> </ul>
	Mirroring population order	A{1, 2, 3, 4, 5, 6}, B{1, 2, 3, 4, 5, 6}, C{1, 2, 3, 4, 5, 6}, D{1, 2, 3, 4, 5, 6}, A{7, 8, 9, 10, 11, 12}, B{7, 8, 9, 10, 11, 12}, C{7, 8, 9, 10, 11, 12}, D{7, 8, 9, 10, 11, 12}	Mirroring is supported with 6 or 12 DIMM slots per processor.
	Single rank sparing population order	A{1}, B{1}, C{1}, D{1}, A{2}, B{2}, C{2}, D{2}, A{3}, B{3}, C{3}, D{3}, A{4}, B{4}, C{4}, D{4}	<ul style="list-style-type: none"> <li>DIMMs must be populated in the order specified.</li> <li>Requires two ranks or more per channel.</li> </ul>
	Multi rank spare population order	A{1}, B{1}, C{1}, D{1}, A{2}, B{2}, C{2}, D{2}, A{3}, B{3}, C{3}, D{3}, A{4}, B{4}, C{4}, D{4}	<ul style="list-style-type: none"> <li>DIMMs must be populated in the order specified.</li> <li>Requires three ranks or more per channel.</li> </ul>
	Fault resilient population order	A{1, 2, 3, 4, 5, 6}, B{1, 2, 3, 4, 5, 6},	Supported with 6 or 12 DIMM slots per processor.

**Table 12. Memory population rules (continued)**

Processor	Configuration	Memory population	Memory population information
		C{1, 2, 3, 4, 5, 6}, D{1, 2, 3, 4, 5, 6} A{7, 8, 9, 10, 11, 12}, B{7, 8, 9, 10, 11, 12}, C{7, 8, 9, 10, 11, 12}, D{7, 8, 9, 10, 11, 12}	

## Removing a memory module

The procedure for removing a DIMM module and an NVDIMM-N module is identical.

### Prerequisites

1. Follow the safety guidelines listed in [Safety instructions](#).
  2. Follow the procedure listed in [Before working inside your system](#).
    - CAUTION:** To prevent data loss and potential damage to your system, ensure that your system, LEDs on system, LEDs on NVDIMM-N and LEDs on NVDIMM-N battery are turned off before removing the NVDIMM-N battery.
  3. [Remove the support bar](#).
  4. [Remove the air shrouds](#).
- WARNING:** Allow the memory modules to cool after you power off the system. Handle the memory modules by the card edges and avoid touching the components or metallic contacts on the memory module.
- CAUTION:** To ensure proper system cooling, memory module blanks must be installed in any memory socket that is not occupied. Remove memory module blanks only if you intend to install memory modules in those sockets.

### Steps

1. Locate the appropriate memory module socket.
  - CAUTION:** Handle each memory module only by the card edges, ensuring not to touch the middle of the memory module or metallic contacts.
2. Push the ejectors outward on both ends of the memory module socket to release the memory module from the socket.
3. Lift and remove the memory module from the system.

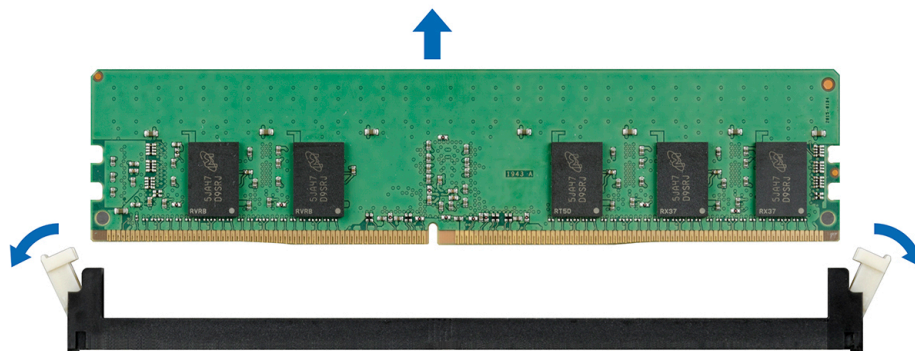

**Figure 72. Removing a memory module**







### Next steps

1. [Replace the memory module](#).







# Installing the memory module

## Prerequisites

-  **CAUTION:** Ensure that you install the NVDIMM-N battery if you are using NVDIMM-N.
  -  **CAUTION:** To prevent data loss and potential damage to your system, ensure that your system, LEDs on system, LEDs on NVDIMM-N and LEDs on NVDIMM-N battery are turned off before installing the NVDIMM-N battery.
  -  **CAUTION:** To ensure proper system cooling, memory module blanks must be installed in any memory socket that is not occupied. Remove memory module blanks only if you intend to install memory modules in those sockets.
  -  **CAUTION:** To ensure proper system cooling in configurations with mid drive tray, memory module blanks must be installed in any memory socket that is not occupied. Remove memory module blanks only if you intend to install memory modules in those sockets.
  -  **NOTE:** You must follow the thermal restriction while using DIMM blank. For information about thermal restriction, see Thermal Restrictions topic in the PowerEdge R940xa Technical Specifications on the product documentation page.
1. Follow the safety guidelines listed in [Safety instructions](#).
  2. Follow the procedure listed in [Before working inside your system](#).
    -  **CAUTION:** To prevent data loss and potential damage to your system, ensure that your system, LEDs on system, LEDs on NVDIMM-N and LEDs on NVDIMM-N battery are turned off before removing the NVDIMM-N battery.
  3. [Remove the support bar](#).
  4. [Remove the air shrouds](#).

## Steps

1. Locate the appropriate memory module socket.
  -  **CAUTION:** Handle each memory module only by the card edges, ensuring not to touch the middle of the memory module or metallic contacts.
  -  **CAUTION:** To prevent damage to the memory module or the memory module socket during installation, do not bend or flex the memory module. You must insert both ends of the memory module simultaneously.
2. Open the ejectors on the memory module socket outward to allow the memory module to be inserted into the socket.
3. Align the edge connector of the memory module with the alignment key of the memory module socket, and insert the memory module in the socket.
  -  **CAUTION:** Do not apply pressure at the center of the memory module; apply pressure at both ends of the memory module evenly.
  -  **NOTE:** The memory module socket has an alignment key that enables you to install the memory module in the socket in only one orientation.
4. Press the memory module with your thumbs until the socket levers firmly click into place.

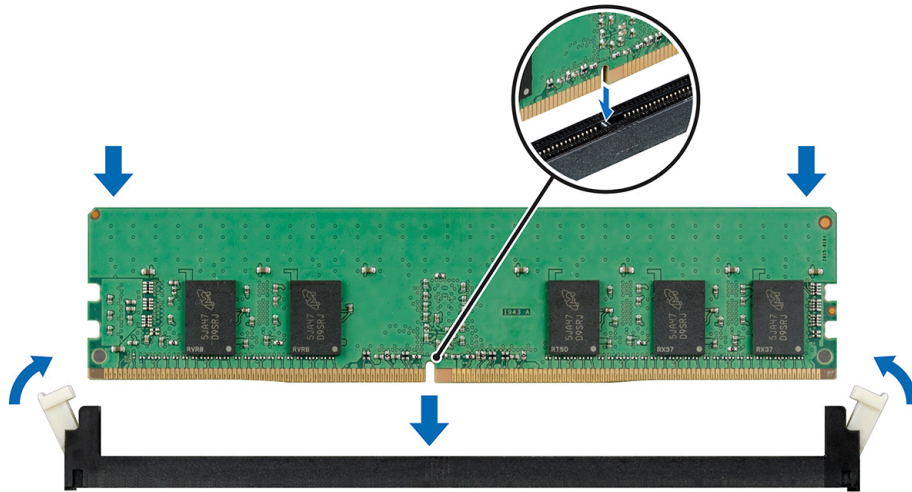

Figure 73. Installing the memory module

### Next steps

1. [Replace the air shrouds.](#)
2. [Replace the support bar.](#)
3. Follow the procedure listed in [After working inside your system.](#)
4. To verify if the memory module has been installed properly, press F2 and navigate to **System Setup Main Menu > System BIOS > Memory Settings**. In the **Memory Settings** screen, the System Memory Size must reflect the updated capacity of the installed memory.
5. If the value is incorrect, one or more of the memory modules may not be installed properly. Ensure that the memory module is firmly seated in the memory module socket.
6. Run the system memory test in system diagnostics.

## Processors and heat sinks

The processor controls memory, peripheral interfaces, and other components of the system. The system can have more than one processor configurations.

The heat sink absorbs the heat generated by the processor, and helps the processor to maintain its optimal temperature level.

## Removing a processor and heat sink module

### Prerequisites

 **WARNING:** The heat sink may be hot to touch for some time after the system is powered down. Allow the heat sink to cool before removing it.

1. Follow the safety guidelines listed in [Safety instructions.](#)
2. Follow the procedure listed in [Before working inside your system.](#)
3. [Remove the support bar.](#)
4. [Remove the air shrouds.](#)
5. [Remove the cooling fan assembly](#), if you are replacing the heat sink 3 or 4.

### Steps

1. Use a Torx #T30 screwdriver to loosen the screws on the heat sink in the order mentioned below:
  - a. Loosen the first screw three turns.
  - b. Loosen the second screw completely.

- c. Return to the first screw and loosen it completely.
2. Push both blue retention clips simultaneously and lift the processor and heat sink module (PHM).
3. Set the PHM aside with the processor side facing up.

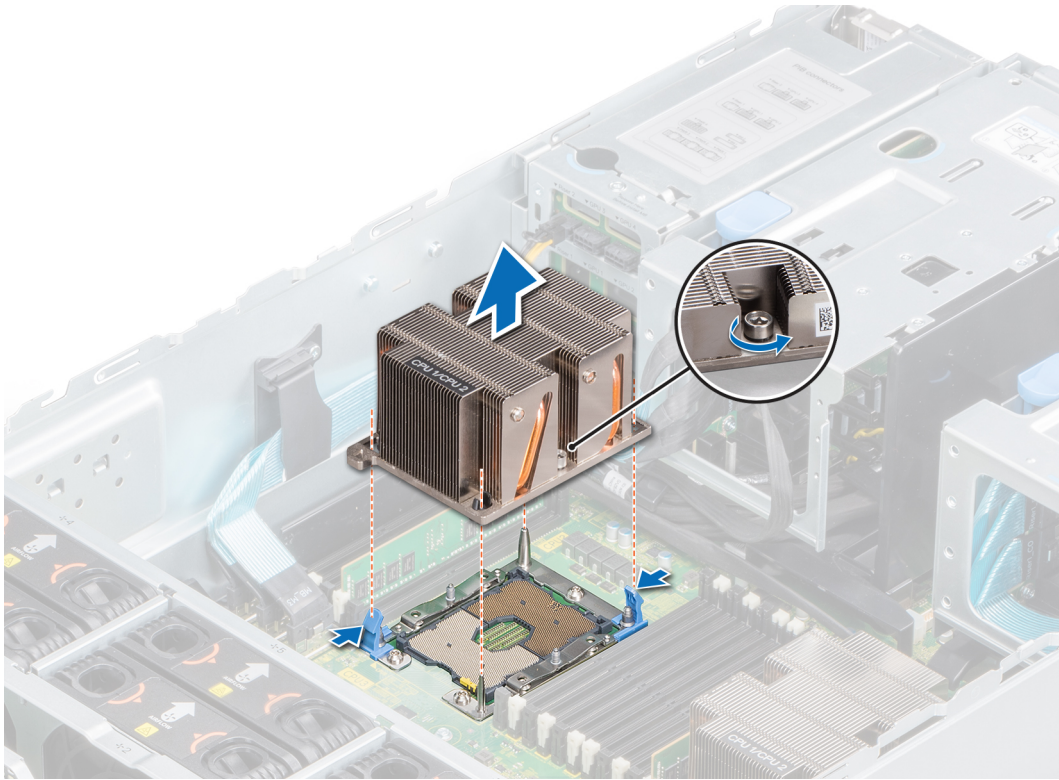

**Figure 74. Removing a PHM from CPU 1 or 2**

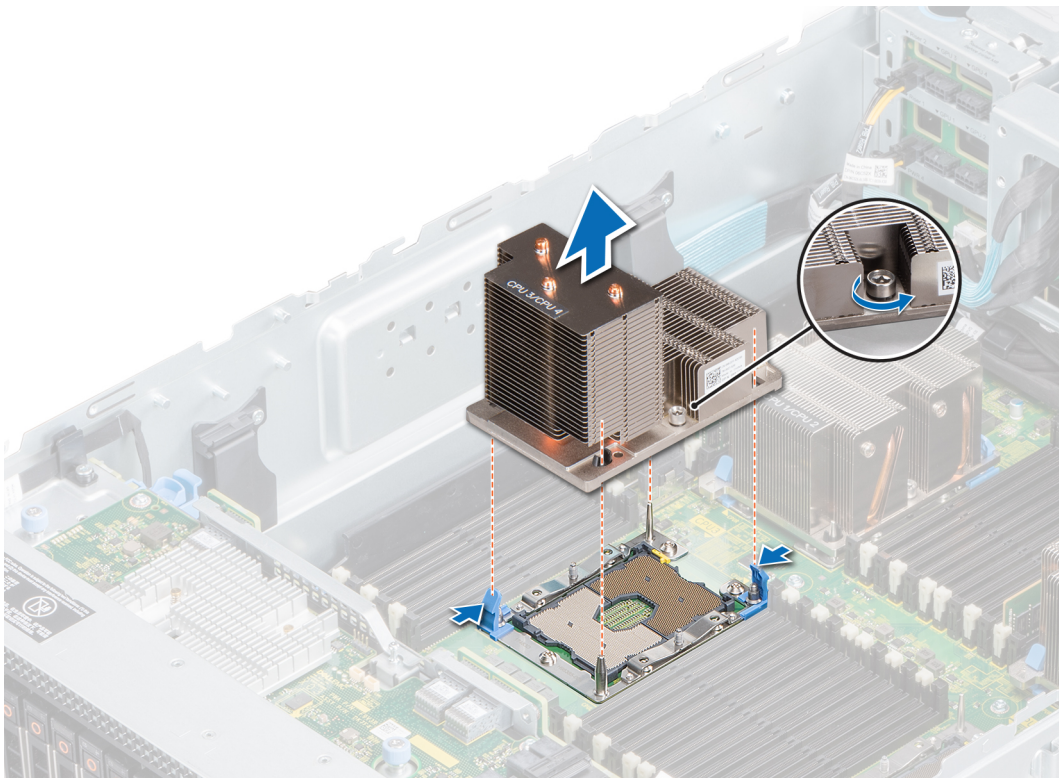

**Figure 75. Removing a PHM from CPU 3 or 4**

### Next steps

1. [Replace the processor and heat sink module.](#)

## Removing the processor from the processor and heat sink module

### Prerequisites

**⚠ WARNING:** The heat sink may be hot to touch for some time after the system has been powered down. Allow the heat sink to cool before removing it.

**ℹ NOTE:** Only remove the processor from the processor and heat sink module if you are replacing the processor or heat sink. This procedure is not required when replacing a system board.

1. Follow the safety guidelines listed in [Safety instructions](#).
2. Follow the procedure listed in [Before working inside your system](#).
3. [Remove the processor and heat sink module.](#)

### Steps

1. Insert a flat blade screwdriver into the release slot marked with a yellow label. Twist (do not pry) the screwdriver to break the thermal paste seal.
2. Push the retaining clips on the processor bracket to unlock the bracket from the heat sink.

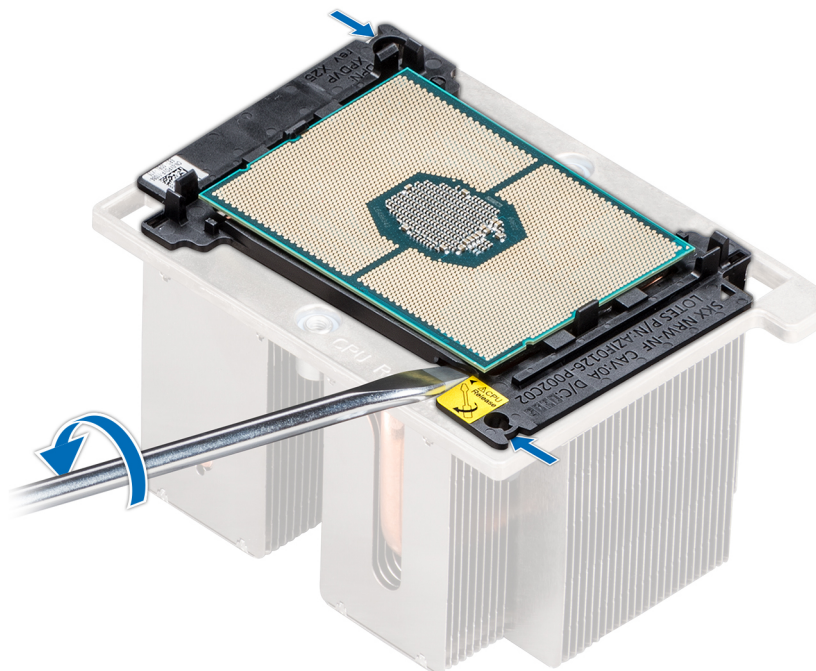
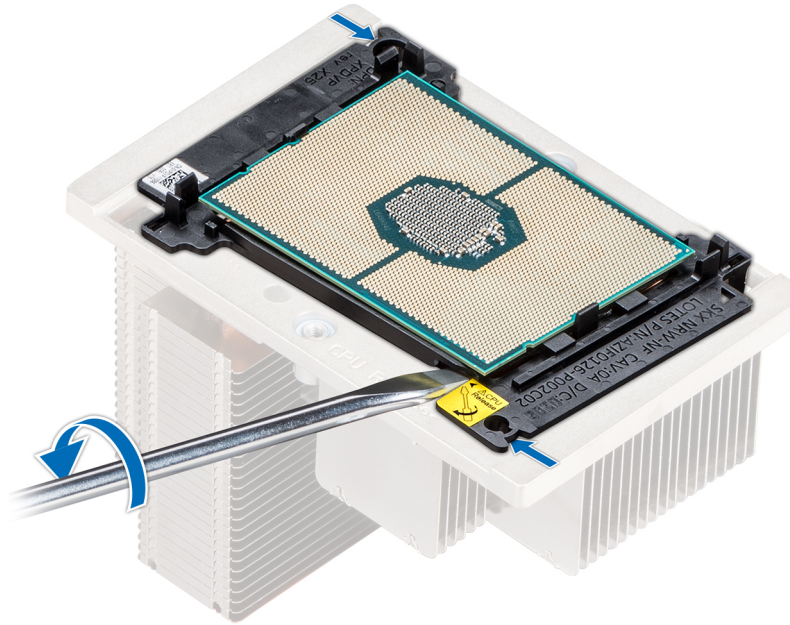

Figure 76. Loosening the processor bracket from CPU 1/2



**Figure 77. Loosening the processor bracket from CPU 3/4**

3. Lift the bracket and the processor from the heat sink, and place the processor connector side down on the processor tray.
4. Flex the outer edges of the bracket to release the bracket from the processor.

**i** **NOTE:** Ensure that the processor and the bracket are placed in the tray after you remove the heat sink.



**Figure 78. Removing the processor bracket**

#### **Next steps**

1. Install the processor or the processor dust cover.

# Installing the processor on the processor and heat sink module

## Prerequisites

**⚠ WARNING:** The heat sink may be hot to touch for some time after the system has been powered down. Allow the heat sink to cool before removing it.

**i NOTE:** Only remove the processor from the processor and heat sink module if you are replacing the processor or heat sink. This procedure is not required when replacing a system board.

1. Follow the safety guidelines listed in [Safety instructions](#).
2. Follow the procedure listed in [Before working inside your system](#).
3. [Install the processor and heat sink module](#).

## Steps

1. Place the processor in the processor tray.

**i NOTE:** Ensure that the pin 1 indicator on the processor tray is aligned with the pin 1 indicator on the processor.

2. Flex the outer edges of the bracket around the processor ensuring that the processor is locked into the clips on the bracket.

**i NOTE:** Ensure that the pin 1 indicator on the bracket is aligned with the pin 1 indicator on the processor before placing the bracket on the processor.

**i NOTE:** Ensure that the processor and the bracket are placed in the tray before you install the heat sink.



**Figure 79. Installing the processor bracket**

3. If you are using an existing heat sink, remove the thermal grease from the heat sink by using a clean lint-free cloth.
4. Use the thermal grease syringe included with your processor kit to apply the grease in a quadrilateral design on the top of the processor.

**⚠ CAUTION:** Applying too much thermal grease can result in excess grease coming in contact with and contaminating the processor socket.

**i NOTE:** The thermal grease syringe is intended for single use only. Dispose the syringe after you use it.



**Figure 80. Applying thermal grease on top of the processor**

5. Place the heat sink on the processor and push down on the base of the heat sink until the bracket locks onto the heat sink.

**NOTE:**

- Ensure that the two guide pin holes on the bracket match the guide holes on the heat sink.
- Do not press on the heat sink fins.
- Ensure that the pin 1 indicator on the heat sink is aligned with the pin 1 indicator on the bracket before placing the heat sink onto the processor and bracket.

**Next steps**

1. [Replace the processor and heat sink module.](#)
2. Follow the procedure listed in [After working inside your system.](#)

## Installing a processor and heat sink module

**Prerequisites**

**CAUTION:** Never remove the heat sink from a processor unless you intend to replace the processor. The heat sink is necessary to maintain proper thermal conditions.

1. Follow the safety guidelines listed in [Safety instructions.](#)
2. Follow the procedure listed in [Before working inside your system.](#)
3. [Remove the support bar.](#)
4. [Remove the air shroud.](#)
5. [Remove the cooling fan assembly.](#)

**Steps**

1. Align the Pin1 indicator on the heat sink with the indicator on the system board and place the processor and heat sink module (PHM) on the processor socket.

**CAUTION:** To avoid damaging the fins on the heat sink, do not press down on the heat sink fins.

**NOTE:** Ensure that the PHM is held parallel to the system board to prevent damaging the components.

2. Push the blue retention clips inward to allow the heat sink to drop in place.
3. Using the Torx #T30 screwdriver to tighten the screws on the heat sink in the order mentioned below:
  - a. Partially tighten the first screw (approximately 3 turns).
  - b. Tighten the second screw completely.
  - c. Return to the first screw and tighten it completely.

If the PHM slips off the blue retention clips when the screws are partially tightened, follow these steps to secure the PHM:

- a. Loosen both the heat sink screws completely.
- b. Lower the PHM on to the blue retention clips.
- c. Secure the PHM to the system board, following the replacement instructions listed in this step mentioned above.

**NOTE:** The processor and heat sink module retention screws should not be tightened to more than 0.13 kgf-m (1.35 N.m or 12 in-lbf).

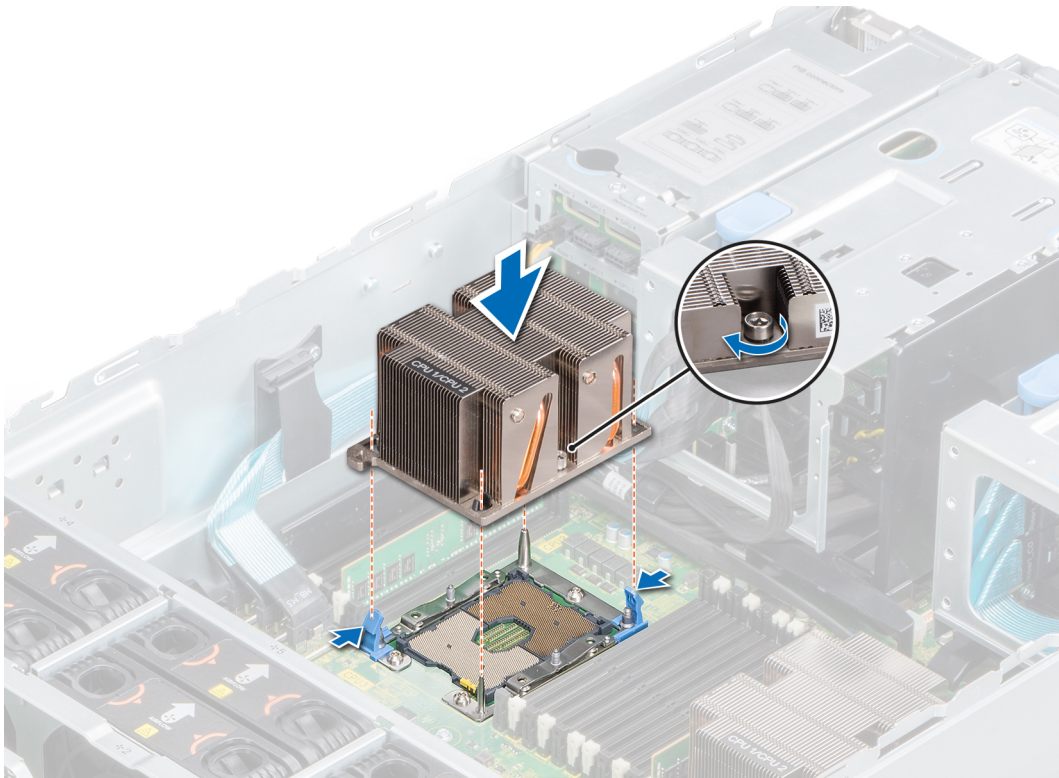

**Figure 81. Installing the PHM on CPU 1 or 2**



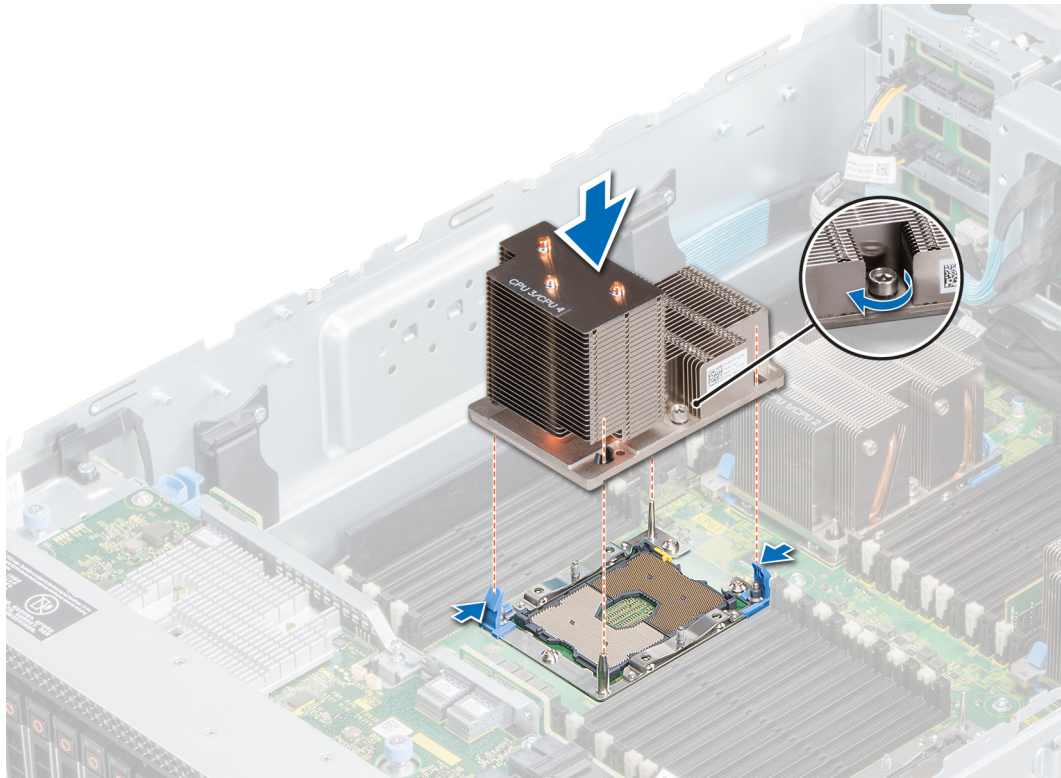

**Figure 82. Installing the PHM on CPU 3 or 4**

#### Next steps

1. Replace the cooling fan assembly.
2. Replace the air shrouds.
3. Replace the support bar
4. Follow the procedure listed in [After working inside your system](#).

## Expansion cards and expansion card risers

An expansion card in the system is an add-on card that can be inserted into an expansion slot on the system board or a slot on a riser card to add enhanced functionality to the system through the expansion bus.

**NOTE:** A System Event Log (SEL) event is logged if an expansion card riser is not supported or missing. It does not prevent your system from turning on. However, if a F1/F2 pause occurs and an error message is displayed.

### Expansion card installation guidelines

The PowerEdge R940xa system supports up to 12 PCI express (PCIe) generation 3 expansion cards, that can be installed on the system board using expansion card risers.

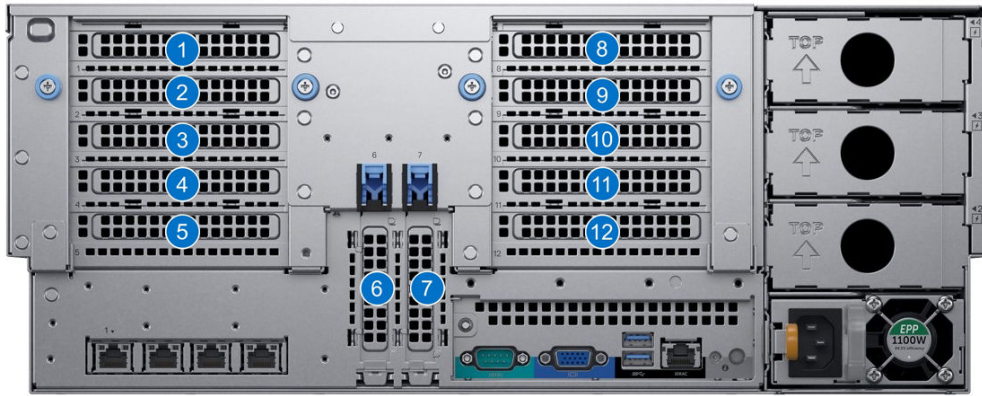

**Figure 83. PCIe slot numbering**

The following table provides detailed information about the expansion card riser specifications:

**Table 13. Expansion card riser specifications**

Number of processors	NVMe	GPU	Riser size	Slot size	Slot quantity	Available slots	Height	Length
4	NA	GPU Ready/ Double wide accelerators capable	X16 PCIe Riser 1	X 16	2	2,4	FH	FL
				X 8	1	5	FH	HL
			X16 PCIe Riser 2	X 16	2	9,11	FH	FL
				X 8	1	12	FH	HL
	NA	Non-GPU/ Single wide FPGA	X8 PCIe Riser 1	X 8	5	1,2,3,4,5	FH	HL
				X8 PCIe Riser 2	X 8	5	8,9,10,11,12	FH
	Front NVMe	GPU Ready/ Double wide accelerators capable	X16 PCIe Riser 1	X 16	2	2,4	FH	FL
				X16 PCIe Riser 2	X 16	2	9,11	FH
Front NVMe	Non-GPU/ Single wide FPGA	X8 PCIe Riser 1	X 8	4	1,2,3,4	FH	HL	
			X8 PCIe Riser 2	X 8	4	8,9,10,11	FH	HL
2	NA	GPU Ready/ Double wide accelerators capable	X16 PCIe Riser 1	X 16	1	4	FH	FL
				X16 PCIe Riser 2	X 16	1	11	FH
	NA	Non-GPU/ Single wide FPGA	X8 PCIe Riser 1	X 8	2	3,4	FH	HL
				X8 PCIe Riser 2	X 8	2	10,11	FH

**NOTE:** Use double-wide accelerator capable for installation or removal of Xilinx card.

**Table 14. Riser configuration (X16PCIe Riser 1+X16 PCIe Riser 2) in a dual processor configuration**

Card Type	Slot Priority	Maximum number of Cards
Intel 25G NICs	11,4	2
Intel 25G NICs	6,7	2
Nvidia GPU	4,11	2

**Table 14. Riser configuration (X16PCIe Riser 1+X16 PCIe Riser 2) in a dual processor configuration (continued)**

Card Type	Slot Priority	Maximum number of Cards
Intel FPGA	11,4	2
Xilinx FPGA  <b>NOTE:</b> Use double-wide accelerator capable for installation or removal of Xilinx card.	11,4	2
Dell design PERC10/11	7	1
Mellanox Infiniband HCA EDR	6,7	2
Mellanox Infiniband HCA EDR	11,4	2
Mellanox 100G NICs	6,7	2
Mellanox 100G NICs	11,4	2
INTEL Omni-Path HFI	6,7	2
INTEL Omni-Path HFI	11,4	2
Dell design BOSS	11,4	1
Dell design BOSS	6,7	1
Dell design External RAID	6,7	2
Dell design External RAID	11,4	2
Mellanox Infiniband HCA FDR	6,7	2
INTEL 40Gb NICs	11,4	2
INTEL 40Gb NICs	6,7	2
Mellanox 40G NICs	6,7	2
Mellanox 40G NICs	11,4	2
Emulex FC32 HBA	11,4	2
Emulex FC32 HBA	6,7	2
Qlogic FC32 HBA	11,4	2
Qlogic FC32 HBA	6,7	2
Broadcom 25G NICs	6,7	2
Broadcom 25G NICs	11,4	2
INTEL 25Gb NICs	11,4	2
INTEL 25Gb NICs	6,7	2
Mellanox 25G NICs	11,4	2
Mellanox 25G NICs	6,7	2
Qlogic 25G NICs	11,4	2
Qlogic 25G NICs	6,7	2
Emulex FC16 HBA	11,4	2
Emulex FC16 HBA	6,7	2
Emulex FC16 HBA (FH, LP)	11,6,7,4	4
Qlogic FC16 HBA	11,4	2
Qlogic FC16 HBA	6,7	2

**Table 14. Riser configuration (X16PCIe Riser 1+X16 PCIe Riser 2) in a dual processor configuration (continued)**

<b>Card Type</b>	<b>Slot Priority</b>	<b>Maximum number of Cards</b>
Broadcom 10Gb NICs	6,7	2
Broadcom 10Gb NICs	11,4	2
Broadcom 10Gb NICs (FH, LP)	11,6,7,4	4
INTEL 10Gb NICs	6,7	2
INTEL 10Gb NICs	11,4	2
Mellanox 10Gb NICs	6,7	2
Mellanox 10Gb NICs	11,4	2
Qlogic 10Gb NICs	11,4	2
Qlogic 10Gb NICs	6,7	2
Solarflare 10Gb NICs	11,4	2
Solarflare 10Gb NICs	6,7	2
Emulex FC8 HBA	6,7	2
Emulex FC8 HBA	11,4	2
Qlogic FC8 HBA	6,7	2
Qlogic FC8 HBA	11,4	2
Broadcom 1Gb NICs	11,4	2
Broadcom 1Gb NICs	6,7	2
INTEL 1Gb NICs	6,7	2
INTEL 1Gb NICs	11,4	2
Dell design Non-RAID	6,7	2
Dell design Non-RAID	11,4	2
Dell design NVMe PCIe SSD	6,7,11,4	4
INTEL rNDC	Integrated Slot	1
Broadcom rNDC	Integrated Slot	1
Mellanox rNDC	Integrated Slot	1
Qlogic rNDC	Integrated Slot	1
GPU	4,11	2
100G NICs	6,7	2
100G NICs	11,4	2
External RAID	6,7	2
External RAID	11,4	2
External RAID	11,4,6,7	4
FC32 HBA	11,4	2
FC32 HBA	6,7	2
25G NICs	11,4	2
25G NICs	6,7	2
10Gb NICs	6,7	2

**Table 14. Riser configuration (X16PCIe Riser 1+X16 PCIe Riser 2) in a dual processor configuration (continued)**

Card Type	Slot Priority	Maximum number of Cards
10Gb NICs	11,4	2
Non-RAID	6,7	2
Non-RAID	11,4	2
Non-RAID	11,4,6,7	4
HBA355e	11, 4, 6, 7	2

**Table 15. Riser configuration (X8PCIe Riser 1+X8 PCIe Riser 2) in a dual processor configuration**

Card Type	Slot Priority	Maximum number of Cards
Intel 25G NICs	3,4,10,11	4
Intel 25G NICs	6,7	2
Dell design PERC10	4	1
Dell design PERC11	7	1
Intel FPGA	3,4,10,11	4
Mellanox Infiniband HCA EDR	6,7	2
Mellanox 100G NICs	6,7	2
INTEL Omni-Path HFI	6,7	2
Dell design BOSS	3,4,10,11	1
Dell design BOSS	6,7	1
Dell design External RAID	6,7	2
Dell design External RAID	3,4,10,11	2
Mellanox Infiniband HCA FDR	6,7	2
INTEL 40Gb NICs	3,4,10,11	4
INTEL 40Gb NICs	6,7	2
Mellanox 40G NICs	6,7	2
Mellanox 40G NICs	3,4,10,11	4
Emulex FC32 HBA	3,4,10,11	4
Emulex FC32 HBA	6,7	2
Qlogic FC32 HBA	3,4,10,11	4
Qlogic FC32 HBA	6,7	2
Broadcom 25G NICs	6,7	2
Broadcom 25G NICs	3,4,10,11	4
INTEL 25Gb NICs	3,4,10,11	4
INTEL 25Gb NICs	6,7	2
Mellanox 25G NICs	3,4,10,11	4
Mellanox 25G NICs	6,7	2
Qlogic 25G NICs	3,4,10,11	4
Qlogic 25G NICs	6,7	2

**Table 15. Riser configuration (X8PCIe Riser 1+X8 PCIe Riser 2) in a dual processor configuration (continued)**

<b>Card Type</b>	<b>Slot Priority</b>	<b>Maximum number of Cards</b>
Emulex FC16 HBA	3,4,10,11	4
Emulex FC16 HBA	6,7	2
Emulex FC16 HBA (FH, LP)	3,4,6,7,10,11	6
Qlogic FC16 HBA	3,4,10,11	4
Qlogic FC16 HBA	6,7	2
Broadcom 10Gb NICs	6,7	2
Broadcom 10Gb NICs	3,4,10,11	4
Broadcom 10Gb NICs (FH, LP)	3,4,6,7,10,11	6
INTEL 10Gb NICs	6,7	2
INTEL 10Gb NICs	3,4,10,11	4
Mellanox 10Gb NICs	6,7	2
Mellanox 10Gb NICs	3,4,10,11	4
Qlogic 10Gb NICs	3,4,10,11	4
Qlogic 10Gb NICs	6,7	2
Solarflare 10Gb NICs	3,4,10,11	4
Solarflare 10Gb NICs	6,7	2
Emulex FC8 HBA	6,7	2
Emulex FC8 HBA	3,4,10,11	4
Qlogic FC8 HBA	6,7	2
Qlogic FC8 HBA	3,4,10,11	4
Broadcom 1Gb NICs	3,4,10,11	4
Broadcom 1Gb NICs	6,7	2
INTEL 1Gb NICs	6,7	2
INTEL 1Gb NICs	3,4,10,11	4
Dell design Non-RAID	6,7	2
Dell design Non-RAID	3,4,10,11	4
Dell design NVMe PCIe SSD	3,4,10,11,6,7	6
INTEL rNDC	Integrated Slot	1
Broadcom rNDC	Integrated Slot	1
Mellanox rNDC	Integrated Slot	1
Qlogic rNDC	Integrated Slot	1
100G NICs	6,7	2
External RAID	6,7	2
External RAID	3,4,10,11	2
External RAID	3,4,10,11,6,7	4
FC32 HBA	3,4,10,11	4
FC32 HBA	6,7	2

**Table 15. Riser configuration (X8PCIe Riser 1+X8 PCIe Riser 2) in a dual processor configuration (continued)**

Card Type	Slot Priority	Maximum number of Cards
25G NICs	3,4,10,11	4
25G NICs	6,7	2
10Gb NICs	3,4,10,11	4
10Gb NICs	6,7	2
Non-RAID	6,7	2
Non-RAID	3,4,10,11	4
Non-RAID	3,4,10,11,6,7	6
HBA355e	3, 4, 10, 11, 6, 7	2
Intel 100G NICs	6, 7	2

**Table 16. Riser configuration (X16PCIe Riser 1+X16 PCIe Riser 2) in a quad processor configuration**

Card Type	Slot Priority	Maximum number of Cards
Intel 25G NICs	5,12,9,11,2,4	6
Intel 25G NICs	6,7	2
Nvidia GPU	4,2,11,9	4
Intel FPGA	9,11,2,4	4
Xilinx FPGA  <b>NOTE:</b> Use double-wide accelerator capable for installation or removal of Xilinx card.	9,11,2,4	4
Dell design PERC10	5	1
Dell design PERC11	7	1
Mellanox Infiniband HCA EDR	6,7	2
Mellanox Infiniband HCA EDR	9,11,2,4	4
Mellanox 100G NICs	6,7	2
Mellanox 100G NICs	9,11,2,4	4
INTEL Omni-Path HFI	6,7	2
INTEL Omni-Path HFI	9,11,2,4	4
Dell design BOSS	5,12,9,11,2,4	1
Dell design BOSS	6,7	1
Dell design External RAID	6,7	2
Dell design External RAID	5,12,9,11,2,4	2
Mellanox Infiniband HCA FDR	6,7	2
INTEL 40Gb NICs	5,12,9,11,2,4	6
INTEL 40Gb NICs	6,7	2
Mellanox 40G NICs	6,7	2
Mellanox 40G NICs	5,12,9,11,2,4	6
Emulex FC32 HBA	5,12,9,11,2,4	6

**Table 16. Riser configuration (X16PCIe Riser 1+X16 PCIe Riser 2) in a quad processor configuration (continued)**

<b>Card Type</b>	<b>Slot Priority</b>	<b>Maximum number of Cards</b>
Emulex FC32 HBA	6,7	2
Qlogic FC32 HBA	5,12,9,11,2,4	6
Qlogic FC32 HBA	6,7	2
Broadcom 25G NICs	6,7	2
Broadcom 25G NICs	5,12,9,11,2,4	6
INTEL 25Gb NICs	5,12,9,11,2,4	6
INTEL 25Gb NICs	6,7	2
Mellanox 25G NICs	5,12,9,11,2,4	6
Mellanox 25G NICs	6,7	2
Qlogic 25G NICs	5,12,9,11,2,4	6
Qlogic 25G NICs	6,7	2
Emulex FC16 HBA	5,12,9,11,2,4	6
Emulex FC16 HBA	6,7	2
Emulex FC16 HBA (FH, LP)	5,12,9,6,7,11,2,4	8
Qlogic FC16 HBA	5,12,9,11,2,4	6
Qlogic FC16 HBA	6,7	2
Broadcom 10Gb NICs	6,7	2
Broadcom 10Gb NICs	5,12,9,11,2,4	6
Broadcom 10Gb NICs (FH, LP)	5,12,9,6,7,11,2,4	8
INTEL 10Gb NICs	6,7	2
INTEL 10Gb NICs	5,12,9,11,2,4	6
Mellanox 10Gb NICs	6,7	2
Mellanox 10Gb NICs	5,12,9,11,2,4	6
Qlogic 10Gb NICs	5,12,9,11,2,4	6
Qlogic 10Gb NICs	6,7	2
Solarflare 10Gb NICs	5,12,9,11,2,4	6
Solarflare 10Gb NICs	6,7	2
Emulex FC8 HBA	6,7	2
Emulex FC8 HBA	5,12,9,11,2,4	6
Qlogic FC8 HBA	6,7	2
Qlogic FC8 HBA	5,12,9,11,2,4	6
Broadcom 1Gb NICs	5,12,9,11,2,4	6
Broadcom 1Gb NICs	6,7	2
INTEL 1Gb NICs	6,7	2
INTEL 1Gb NICs	5,12,9,11,2,4	6
Dell design Non-RAID	6,7	2
Dell design Non-RAID	5,12,9,11,2,4	6



**Table 16. Riser configuration (X16PCIe Riser 1+X16 PCIe Riser 2) in a quad processor configuration (continued)**

Card Type	Slot Priority	Maximum number of Cards
Dell design NVMe PCIe SSD	5,12,6,7,9,11,2,4	8
INTEL rNDC	Integrated Slot	1
Broadcom rNDC	Integrated Slot	1
Mellanox rNDC	Integrated Slot	1
Qlogic rNDC	Integrated Slot	1
GPU	4,2,11,9	4
100G NICs	6,7	2
100G NICs	9,11,2,4	4
External RAID	6,7	2
External RAID	5,12,9,11,2,4	2
External RAID	5,12,9,11,2,4,6,7	4
FC32 HBA	5,12,9,11,2,4	6
FC32 HBA	6,7	2
25G NICs	5,12,9,11,2,4	6
10Gb NICs	6,7	2
10Gb NICs	5,12,9,11,2,4	6
10Gb NICs	6,7	2
Non-RAID	6,7	2
Non-RAID	5,12,9,11,2,4	6
Non-RAID	5,12,9,11,2,4,6,7	8
HBA355e	5, 12, 9, 11, 2, 4, 6, 7	2

**Table 17. Riser configuration (X8PCIe Riser 1+X8 PCIe Riser 2) in a quad processor configuration**

Card Type	Slot Priority	Maximum number of Cards
Intel 25G NICs	1,2,3,4,5,8,9,10,11,12	10
Intel 25G NICs	6,7	2
Dell design PERC10	5	1
Dell design PERC11	7	1
Intel FPGA	1,2,3,4,8,9,10,11	8
Mellanox Infiniband HCA EDR	6,7	2
Mellanox 100G NICs	6,7	2
INTEL Omni-Path HFI	6,7	2
Dell design BOSS	1,2,3,4,5,8,9,10,11,12	1
Dell design BOSS	6,7	1
Dell design External RAID	6,7	2
Dell design External RAID	1,2,3,4,5,8,9,10,11,12	2
Mellanox Infiniband HCA FDR	6,7	2

**Table 17. Riser configuration (X8PCIe Riser 1+X8 PCIe Riser 2) in a quad processor configuration (continued)**

<b>Card Type</b>	<b>Slot Priority</b>	<b>Maximum number of Cards</b>
INTEL 40Gb NICs	1,2,3,4,5,8,9,10,11,12	10
INTEL 40Gb NICs	6,7	2
Mellanox 40G NICs	6,7	2
Mellanox 40G NICs	1,2,3,4,5,8,9,10,11,12	10
Emulex FC32 HBA	1,2,3,4,5,8,9,10,11,12	10
Emulex FC32 HBA	6,7	2
Qlogic FC32 HBA	1,2,3,4,5,8,9,10,11,12	10
Qlogic FC32 HBA	6,7	2
Broadcom 25G NICs	6,7	2
Broadcom 25G NICs	1,2,3,4,5,8,9,10,11,12	10
INTEL 25Gb NICs	1,2,3,4,5,8,9,10,11,12	10
INTEL 25Gb NICs	6,7	2
Mellanox 25G NICs	1,2,3,4,5,8,9,10,11,12	10
Mellanox 25G NICs	6,7	2
Qlogic 25G NICs	1,2,3,4,5,8,9,10,11,12	10
Qlogic 25G NICs	6,7	2
Emulex FC16 HBA	1,2,3,4,5,8,9,10,11,12	10
Emulex FC16 HBA	6,7	2
Emulex FC16 HBA (FH, LP)	1,2,3,4,5,6,7,8,9,10,11,12	12
Qlogic FC16 HBA	1,2,3,4,5,8,9,10,11,12	10
Qlogic FC16 HBA	6,7	2
Broadcom 10Gb NICs	6,7	2
Broadcom 10Gb NICs	1,2,3,4,5,8,9,10,11,12	10
Broadcom 10Gb NICs (FH, LP)	1,2,3,4,5,6,7,8,9,10,11,12	12
INTEL 10Gb NICs	6,7	2
INTEL 10Gb NICs	1,2,3,4,5,8,9,10,11,12	10
Mellanox 10Gb NICs	6,7	2
Mellanox 10Gb NICs	1,2,3,4,5,8,9,10,11,12	10
Qlogic 10Gb NICs	1,2,3,4,5,8,9,10,11,12	10
Qlogic 10Gb NICs	6,7	2
Solarflare 10Gb NICs	1,2,3,4,5,8,9,10,11,12	10
Solarflare 10Gb NICs	6,7	2
Emulex FC8 HBA	6,7	2
Emulex FC8 HBA	1,2,3,4,5,8,9,10,11,12	10
Qlogic FC8 HBA	6,7	2
Qlogic FC8 HBA	1,2,3,4,5,8,9,10,11,12	10
Broadcom 1Gb NICs	1,2,3,4,5,8,9,10,11,12	10

**Table 17. Riser configuration (X8PCIe Riser 1+X8 PCIe Riser 2) in a quad processor configuration (continued)**

Card Type	Slot Priority	Maximum number of Cards
Broadcom 1Gb NICs	6,7	2
INTEL 1Gb NICs	6,7	2
INTEL 1Gb NICs	1,2,3,4,5,8,9,10,11,12	10
Dell design Non-RAID	6,7	2
Dell design Non-RAID	1,2,3,4,5,8,9,10,11,12	10
Dell design NVMe PCIe SSD	1,2,3,4,5,8,9,10,11,12,6,7	12
INTEL rNDC	Integrated Slot	1
Broadcom rNDC	Integrated Slot	1
Mellanox rNDC	Integrated Slot	1
Qlogic rNDC	Integrated Slot	1
100G NICs	6,7	2
External RAID	6,7	2
External RAID	1,2,3,4,5,8,9,10,11,12	2
External RAID	1,2,3,4,5,8,9,10,11,12,6,7	4
FC32 HBA	1,2,3,4,5,8,9,10,11,12	10
FC32 HBA	6,7	2
25G NICs	1,2,3,4,5,8,9,10,11,12	10
25G NICs	6,7	2
10Gb NICs	6,7	2
10Gb NICs	1,2,3,4,5,8,9,10,11,12	10
Non-RAID	6,7	2
Non-RAID	1,2,3,4,5,8,9,10,11,12	10
Non-RAID	1,2,3,4,5,8,9,10,11,12,6,7	12
HBA355e	1, 2, 3, 4, 5, 8, 9, 10, 11, 12, 6, 7	2

**Table 18. Riser configuration (X16PCIe Riser 1+X16 PCIe Riser 2)with NVME in a quad processor configuration**

Card Type	Slot Priority	Maximum number of Cards
Intel 25G NICs	9,11,2,4	4
Intel 25G NICs	6,7	2
Nvidia GPU	4,2,11,9	4
Intel FPGA	9,11,2,4	4
Xilinx FPGA  <b>NOTE:</b> Use double-wide accelerator capable for installation or removal of Xilinx card.	9,11,2,4	4
Dell design PERC10/11	7	1
Mellanox Infiniband HCA EDR	6,7	2

**Table 18. Riser configuration (X16PCIe Riser 1+X16 PCIe Riser 2)with NVME in a quad processor configuration (continued)**

Card Type	Slot Priority	Maximum number of Cards
Mellanox Infiniband HCA EDR <b>i</b> <b>NOTE:</b> Mellanox CX6 card only supports install in slot 11 and slot 4 for quad processors configuration.	9,11,2,4	4
Mellanox 100G NICs	6,7	2
Mellanox 100G NICs	9,11,2,4	4
INTEL Omni-Path HFI	6,7	2
INTEL Omni-Path HFI	9,11,2,4	4
Dell design BOSS	9,11,2,4	1
Dell design BOSS	6,7	1
Dell design External RAID	6,7	2
Dell design External RAID	9,11,2,4	2
Mellanox Infiniband HCA FDR	6,7	2
INTEL 40Gb NICs	9,11,2,4	4
INTEL 40Gb NICs	6,7	2
Mellanox 40G NICs	6,7	2
Mellanox 40G NICs	9,11,2,4	4
Emulex FC32 HBA	9,11,2,4	4
Emulex FC32 HBA	6,7	2
Qlogic FC32 HBA	9,11,2,4	4
Qlogic FC32 HBA	6,7	2
Broadcom 25G NICs	6,7	2
Broadcom 25G NICs	9,11,2,4	4
INTEL 25Gb NICs	9,11,2,4	4
INTEL 25Gb NICs	6,7	2
Mellanox 25G NICs	9,11,2,4	4
Mellanox 25G NICs	6,7	2
Qlogic 25G NICs	9,11,2,4	4
Qlogic 25G NICs	6,7	2
Emulex FC16 HBA	9,11,2,4	4
Emulex FC16 HBA	6,7	2
Emulex FC16 HBA (FH, LP)	9,11,6,7,2,4	6
Qlogic FC16 HBA	9,11,2,4	4
Qlogic FC16 HBA	6,7	2
Broadcom 10Gb NICs	6,7	2
Broadcom 10Gb NICs	9,11,2,4	4
Broadcom 10Gb NICs (FH, LP)	9,11,6,7,2,4	6

**Table 18. Riser configuration (X16PCIe Riser 1+X16 PCIe Riser 2)with NVME in a quad processor configuration (continued)**

<b>Card Type</b>	<b>Slot Priority</b>	<b>Maximum number of Cards</b>
INTEL 10Gb NICs	6,7	2
INTEL 10Gb NICs	9,11,2,4	4
Mellanox 10Gb NICs	6,7	2
Mellanox 10Gb NICs	9,11,2,4	4
Qlogic 10Gb NICs	9,11,2,4	4
Qlogic 10Gb NICs	6,7	2
Solarflare 10Gb NICs	9,11,2,4	4
Solarflare 10Gb NICs	6,7	2
Emulex FC8 HBA	6,7	2
Emulex FC8 HBA	9,11,2,4	4
Qlogic FC8 HBA	6,7	2
Qlogic FC8 HBA	9,11,2,4	4
Broadcom 1Gb NICs	9,11,2,4	4
Broadcom 1Gb NICs	6,7	2
INTEL 1Gb NICs	6,7	2
INTEL 1Gb NICs	9,11,2,4	4
Dell design Non-RAID	6,7	2
Dell design Non-RAID	9,11,2,4	4
Dell design NVMe PCIe SSD	6,7,9,11,2,4	6
INTEL rNDC	Integrated Slot	1
Broadcom rNDC	Integrated Slot	1
Mellanox rNDC	Integrated Slot	1
Qlogic rNDC	Integrated Slot	1
GPU	4,2,11,9	4
100G NICs	6,7	2
100G NICs	9,11,2,4	4
External RAID	6,7	2
External RAID	9,11,2,4	2
External RAID	9,11,2,4,6,7	4
FC32 HBA	9,11,2,4	4
FC32 HBA	6,7	2
25G NICs	9,11,2,4	4
25G NICs	6,7	2
10Gb NICs	6,7	2
10Gb NICs	9,11,2,4	4
Non-RAID	6,7	2
Non-RAID	9,11,2,4	4

**Table 18. Riser configuration (X16PCIe Riser 1+X16 PCIe Riser 2)with NVME in a quad processor configuration (continued)**

Card Type	Slot Priority	Maximum number of Cards
Non-RAID	9,11,2,4,6,7	6
HBA355e	9, 11, 2, 4, 6, 7	2

**Table 19. Riser configuration (X8PCIe Riser 1+X8 PCIe Riser 2)with NVME in a quad processor configuration**

Card Type	Slot Priority	Maximum number of Cards
Intel 25G NICs	1,2,3,4,8,9,10,11	8
Intel 25G NICs	6,7	2
Dell design PERC10	4	1
Dell design PERC11	7	1
Intel FPGA	1,2,3,4,8,9,10,11	8
Mellanox Infiniband HCA EDR	6,7	2
Mellanox 100G NICs	6,7	2
INTEL Omni-Path HFI	6,7	2
Dell design BOSS	1,2,3,4,8,9,10,11	1
Dell design BOSS	6,7	1
Dell design External RAID	6,7	2
Dell design External RAID	1,2,3,4,8,9,10,11	2
Mellanox Infiniband HCA FDR	6,7	2
INTEL 40Gb NICs	1,2,3,4,8,9,10,11	8
INTEL 40Gb NICs	6,7	2
Mellanox 40G NICs	6,7	2
Mellanox 40G NICs	1,2,3,4,8,9,10,11	8
Emulex FC32 HBA	1,2,3,4,8,9,10,11	8
Emulex FC32 HBA	6,7	2
Qlogic FC32 HBA	1,2,3,4,8,9,10,11	8
Qlogic FC32 HBA	6,7	2
Broadcom 25G NICs	6,7	2
Broadcom 25G NICs	1,2,3,4,8,9,10,11	8
INTEL 25Gb NICs	1,2,3,4,8,9,10,11	8
INTEL 25Gb NICs	6,7	2
Mellanox 25G NICs	1,2,3,4,8,9,10,11	8
Mellanox 25G NICs	6,7	2
Qlogic 25G NICs	1,2,3,4,8,9,10,11	8
Qlogic 25G NICs	6,7	2
Emulex FC16 HBA	1,2,3,4,8,9,10,11	8
Emulex FC16 HBA	6,7	2
Emulex FC16 HBA (FH, LP)	1,2,3,4,6,7,8,9,10,11	10

**Table 19. Riser configuration (X8PCIe Riser 1+X8 PCIe Riser 2)with NVME in a quad processor configuration (continued)**

<b>Card Type</b>	<b>Slot Priority</b>	<b>Maximum number of Cards</b>
Qlogic FC16 HBA	1,2,3,4,8,9,10,11	8
Qlogic FC16 HBA	6,7	2
Broadcom 10Gb NICs	6,7	2
Broadcom 10Gb NICs	1,2,3,4,8,9,10,11	8
Broadcom 10Gb NICs (FH, LP)	1,2,3,4,6,7,8,9,10,11	10
INTEL 10Gb NICs	6,7	2
INTEL 10Gb NICs	1,2,3,4,8,9,10,11	8
Mellanox 10Gb NICs	6,7	2
Mellanox 10Gb NICs	1,2,3,4,8,9,10,11	8
Qlogic 10Gb NICs	1,2,3,4,8,9,10,11	8
Qlogic 10Gb NICs	6,7	2
Solarflare 10Gb NICs	1,2,3,4,8,9,10,11	8
Solarflare 10Gb NICs	6,7	2
Emulex FC8 HBA	6,7	2
Emulex FC8 HBA	1,2,3,4,8,9,10,11	8
Qlogic FC8 HBA	6,7	2
Qlogic FC8 HBA	1,2,3,4,8,9,10,11	8
Broadcom 1Gb NICs	1,2,3,4,8,9,10,11	8
Broadcom 1Gb NICs	6,7	2
INTEL 1Gb NICs	6,7	2
INTEL 1Gb NICs	1,2,3,4,8,9,10,11	8
Dell design Non-RAID	6,7	2
Dell design Non-RAID	1,2,3,4,8,9,10,11	8
Dell design NVMe PCIe SSD	1,2,3,4,8,9,10,11,6,7	10
INTEL rNDC	Integrated Slot	1
Broadcom rNDC	Integrated Slot	1
Mellanox rNDC	Integrated Slot	1
Qlogic rNDC	Integrated Slot	1
100G NICs	6,7	2
External RAID	6,7	2
External RAID	1,2,3,4,8,9,10,11	2
External RAID	1,2,3,4,8,9,10,11,6,7	4
FC32 HBA	1,2,3,4,8,9,10,11	8
FC32 HBA	6,7	2
25G NICs	1,2,3,4,8,9,10,11	8
25G NICs	6,7	2
10Gb NICs	6,7	2

**Table 19. Riser configuration (X8PCIe Riser 1+X8 PCIe Riser 2)with NVME in a quad processor configuration (continued)**

Card Type	Slot Priority	Maximum number of Cards
10Gb NICs	1,2,3,4,8,9,10,11	8
10Gb NICs	6,7	2
Non-RAID	6,7	2
Non-RAID	1,2,3,4,8,9,10,11,6,7	10
HBA355e	1, 2, 3, 4, 8, 9, 10, 11, 6, 7	2
Broadcom 100G NICs	6, 7	2
Intel 100G NICs	6, 7	2

**NOTE:** For information about slot form factor, see [Expansion card riser specifications](#).

**NOTE:** The expansion card slots are not hot-swappable.

## Removing the expansion card riser

### Prerequisites

**NOTE:** Do not remove the power interposer board cable from the risers.

1. Follow the safety guidelines listed in [Safety instructions](#).
2. Follow the procedure listed in [Before working inside your system](#).
3. [Remove the support bar](#).
4. [Remove the air shrouds](#).

### Steps

1. Disconnect the cables from the Power Interposer Board (PIB), system board, and the backplane.

**NOTE:** Ensure that you remove the cables that are secured using the cable securing bracket routed along the chassis wall.

**NOTE:** Remove the drive cable and the system board cables.

2. Loosen the two thumb screws on the rear of the system chassis.
3. Press the release tab, and holding the riser by the blue touch points, lift the riser from the system.



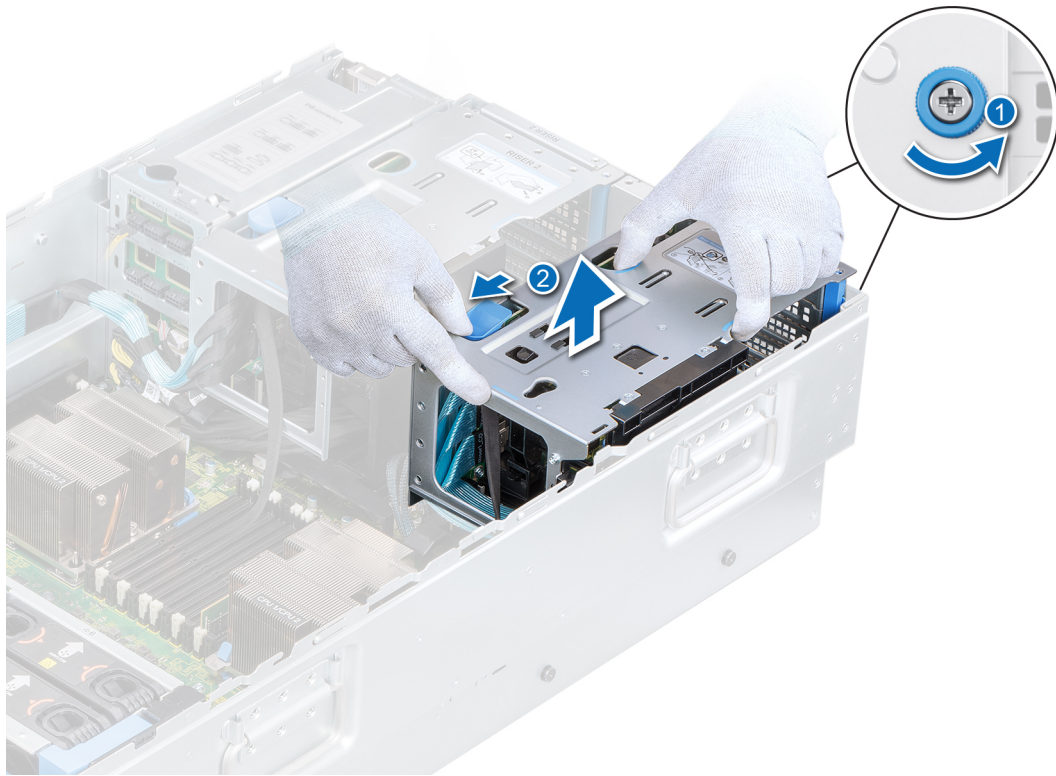

Figure 84. Removing the X8 PCIe Riser 1



**Figure 85. Removing the X8 PCIe Riser 2**

**i** **NOTE:** You must install a filler bracket over an empty expansion card slot to maintain Federal Communications Commission (FCC) certification of the system. The brackets also keep dust and dirt out of the system and aid in proper cooling and airflow inside the system.

#### Next steps

1. [Replace the expansion card riser.](#)

## Installing the expansion card riser

#### Prerequisites

1. Follow the safety guidelines listed in [Safety instructions](#).
2. Follow the procedure listed in [Before working inside your system](#).
3. [Remove the support bar.](#)
4. [Remove the air shrouds.](#)

#### Steps

1. Align the riser with the slots on the rear of the system and lower the riser until it locks into place.
2. Tighten the two thumb screws that secure the riser to the system.
3. Reconnect the cables connected to the Power Interposer Board (PIB), system board, and the backplane.

**i** **NOTE:** Ensure that the cables inside the system are routed along the chassis wall and secured using the cable securing bracket.

**i** **NOTE:** Route the cables properly when you replace them to prevent them from being pinched or crimped.

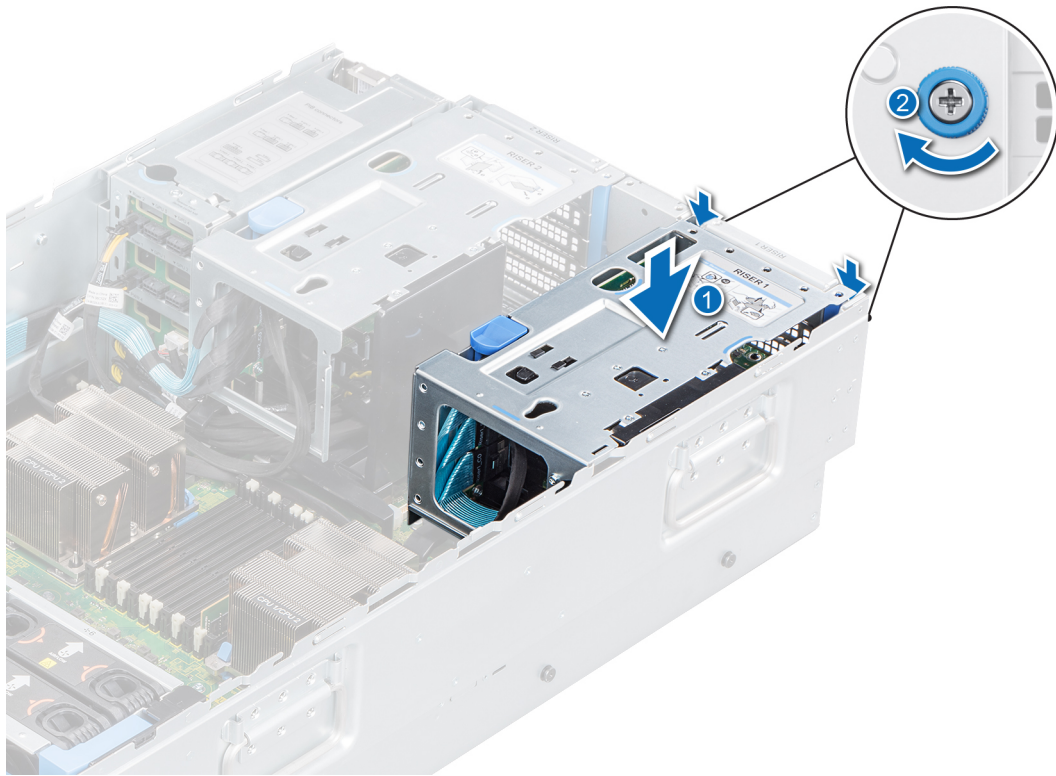

**Figure 86. Installing the X8 PCIe Riser 1**

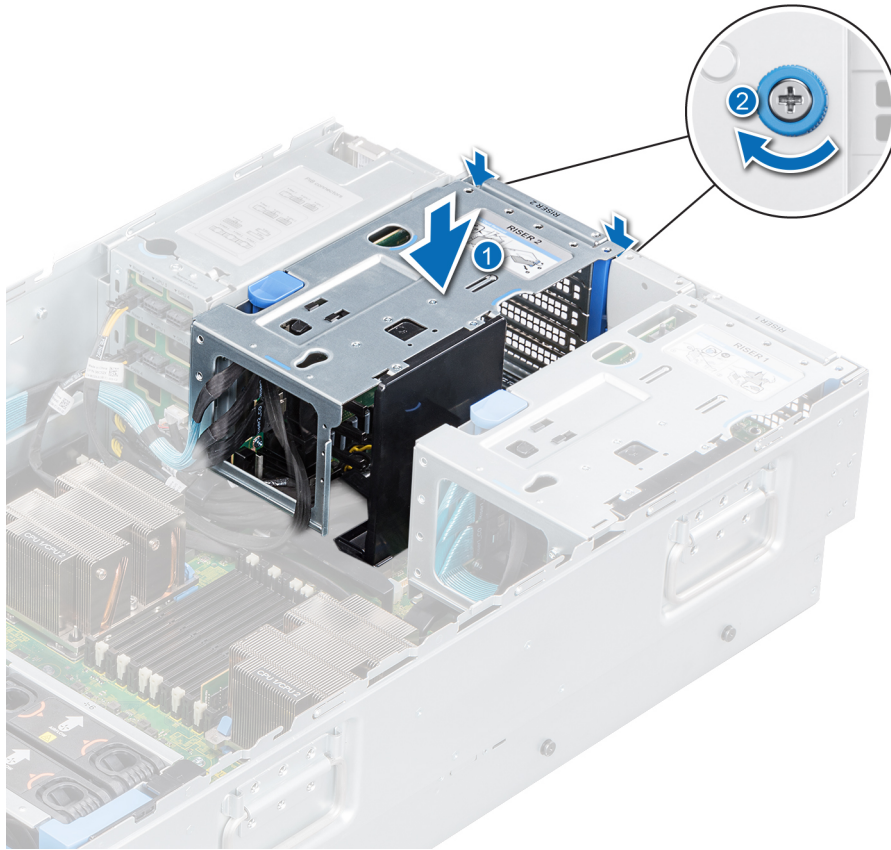

**Figure 87. Installing the X8 PCIe Riser 2**

#### **Next steps**

1. [Replace the air shrouds.](#)
2. [Replace the support bar.](#)
3. Follow the procedure listed in [After working inside your system.](#)

## **Removing the expansion card from the riser**

#### **Prerequisites**

1. Follow the safety guidelines listed in [Safety instructions.](#)
2. Follow the procedure listed in [Before working inside your system.](#)
3. [Remove the support bar.](#)
4. [Remove the air shrouds.](#)
5. [Remove the expansion card riser.](#)

#### **Steps**

1. Press and slide the release button upwards to lift the cover.
2. Open the card retention latch.
3. Lift the card to disengage it from the connector on the riser.

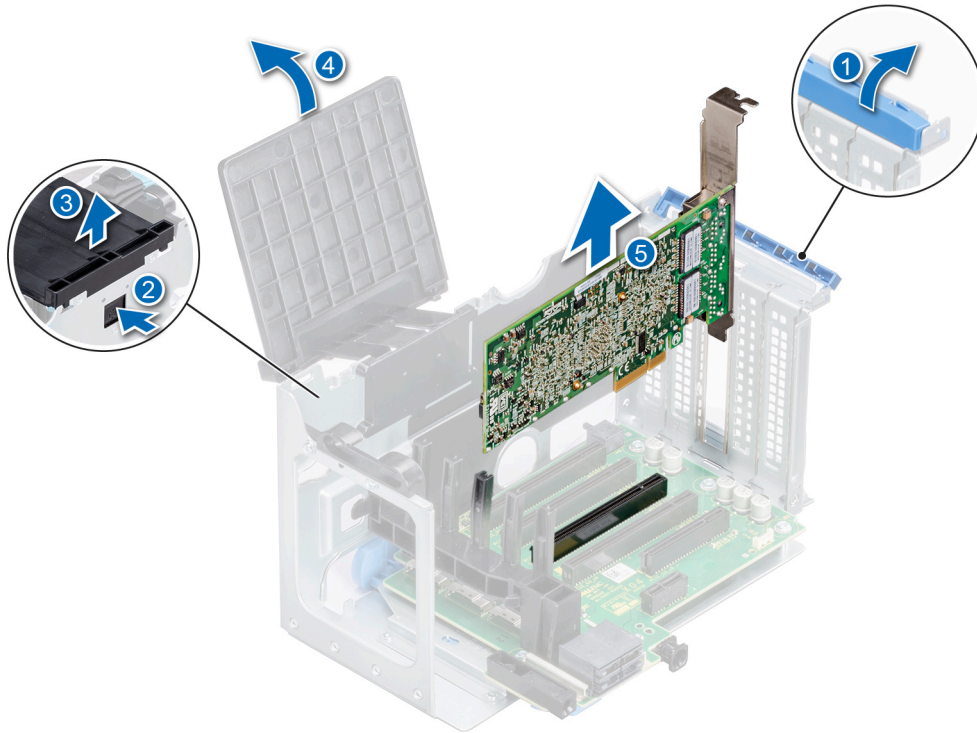

**Figure 88. Removing the expansion card from the riser**

### Next steps

1. Install a filler bracket if you are not going to replace the expansion card.  
**i** **NOTE:** You must install a filler bracket over an empty expansion card slot to maintain Federal Communications Commission (FCC) certification of the system. The brackets also keep dust and dirt out of the system and aid in proper cooling and airflow inside the system.
2. [Replace the expansion card in the riser.](#)

## Installing the expansion card in the riser

### Prerequisites

1. Follow the safety guidelines listed in [Safety instructions](#).
2. If installing a new expansion card, unpack it and prepare the card for installation.  
**i** **NOTE:** For instructions, see the documentation accompanying the card.
3. [Remove the support bar.](#)
4. [Remove the air shrouds.](#)
5. [Remove the expansion card riser.](#)

### Steps

1. Press and slide the release button upwards to lift the cover.
2. Open the card retention latch.
3. Align the card with the guide slots and insert it until the card is fully seated.
4. Close the card retention latch.

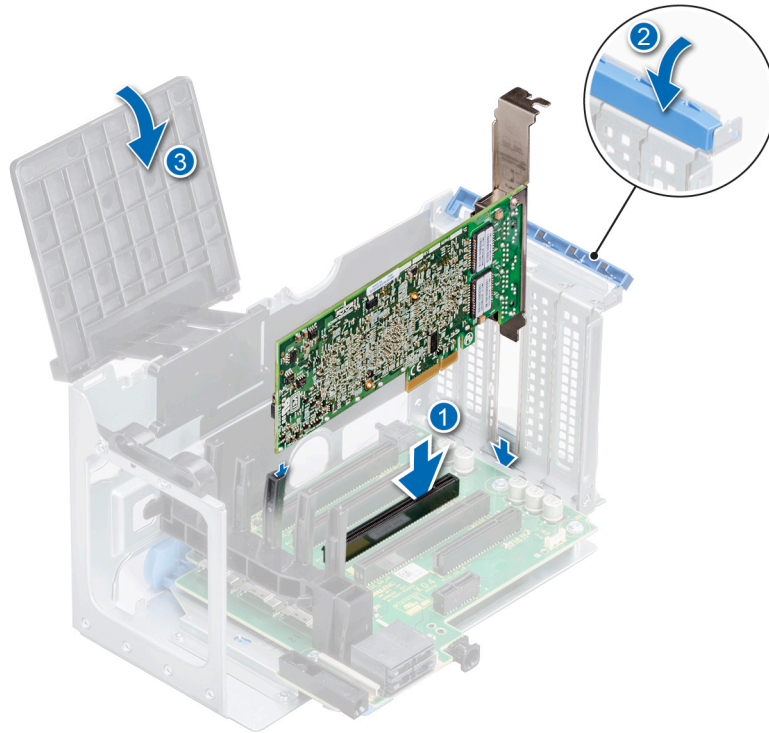

**Figure 89. Installing the expansion card riser**

#### Next steps

1. [Replace the expansion card riser.](#)
2. [Replace the air shrouds.](#)
3. [Replace the support bar](#)
4. Follow the procedure listed in [After working inside your system.](#)

## Removing the expansion card from the system board

#### Prerequisites

1. Follow the safety guidelines listed in [Safety instructions.](#)
2. Follow the procedure listed in [Before working inside your system.](#)
3. [Remove the support bar.](#)
4. [Remove the air shrouds.](#)
5. [Remove the expansion card riser.](#)
6. If applicable, disconnect the cables connected to the expansion card.

#### Steps

1. Press the card retention latch and open it.
2. Hold the expansion card by its edge, and lift the expansion card until the card edge connector disengages from the connector on the system board.
3. Lift the expansion card out of the system.

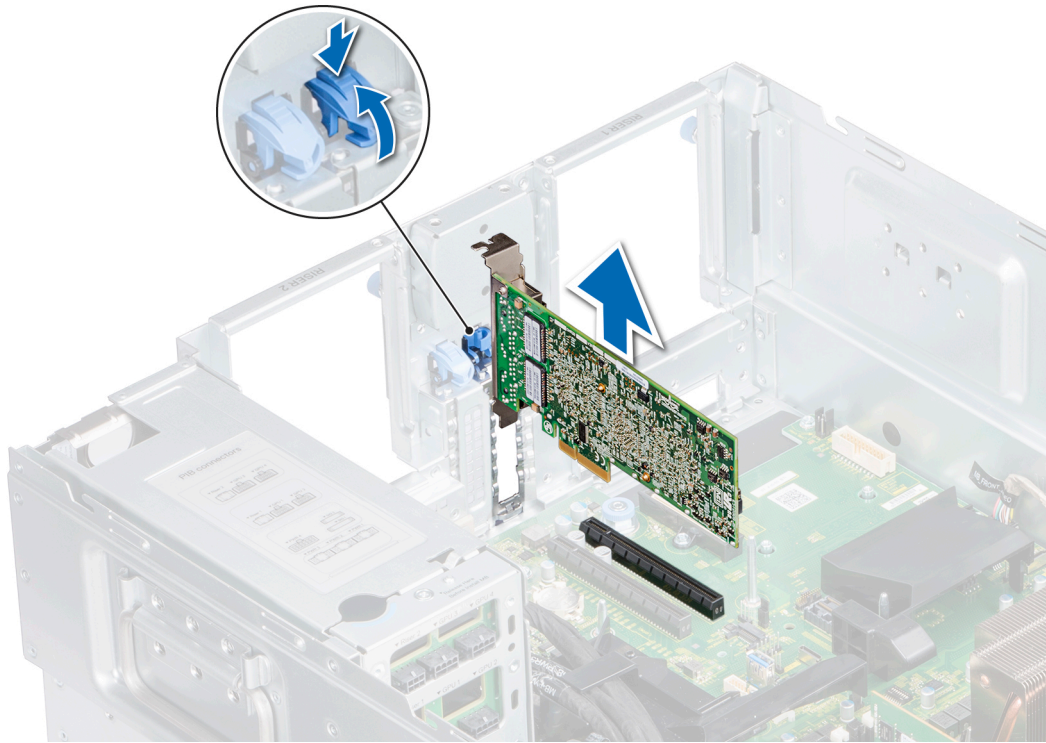

**Figure 90. Removing the Expansion card**

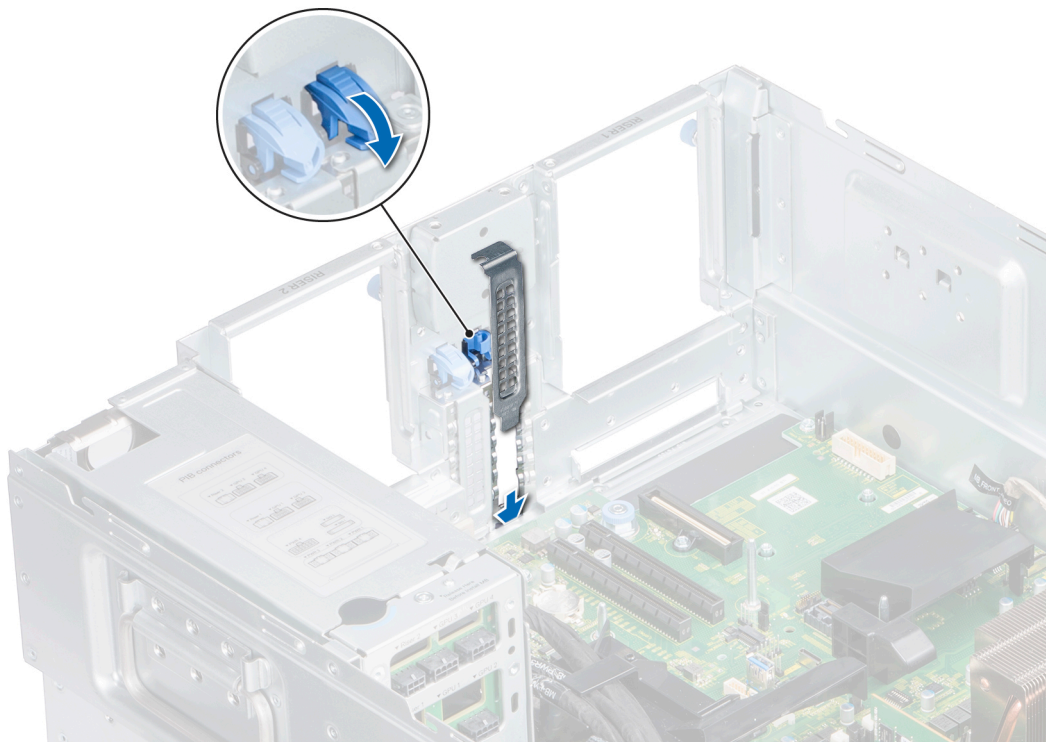

**Figure 91. Installing the filler bracket from a riser**

**Next steps**

1. Install a filler bracket if you are not going to replace the expansion card.

**NOTE:** Store the filler bracket for future use. Filler brackets must be installed in empty expansion card slots to maintain Federal Communications Commission (FCC) certification of the system. The brackets also keep dust and dirt out of the system and aid in proper cooling and airflow inside the system.

2. Replace the expansion card riser.

## Installing the expansion card on the system board

### Prerequisites

1. Follow the safety guidelines listed in [Safety instructions](#).
2. Follow the procedure listed in [Before working inside your system](#).
3. [Remove the support bar](#).
4. [Remove the air shrouds](#).
5. [Remove the expansion card riser](#).
6. If applicable, disconnect the cables connected to the Power Interposer Board (PIB), System Board, and backplane.

**NOTE:** Ensure that the cables are routed correctly before installing the riser. Incorrectly installed cables may get damaged.
7. If installing a new expansion card, unpack it and prepare the card for installation.
8. Unpack the expansion card and prepare it for installation.

**NOTE:** For instructions, see the documentation accompanying the card.

### Steps

1. Lift and open the blue expansion card retention latch.
  2. Pull the filler bracket out of the system.
- Remove the existing expansion card or filler bracket from the expansion card holder.

**NOTE:** Store the filler bracket for future use. Filler brackets must be installed in empty expansion card slots to maintain Federal Communications Commission (FCC) certification of the system. The brackets also keep dust and dirt out of the system and aid in proper cooling and airflow inside the system.

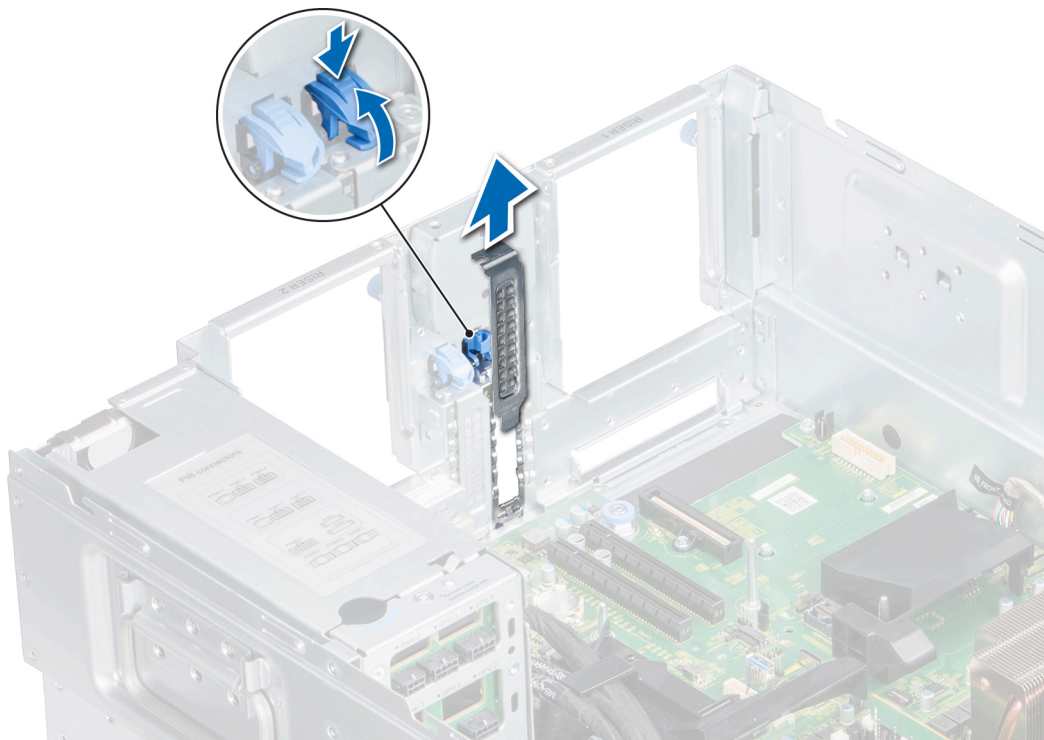
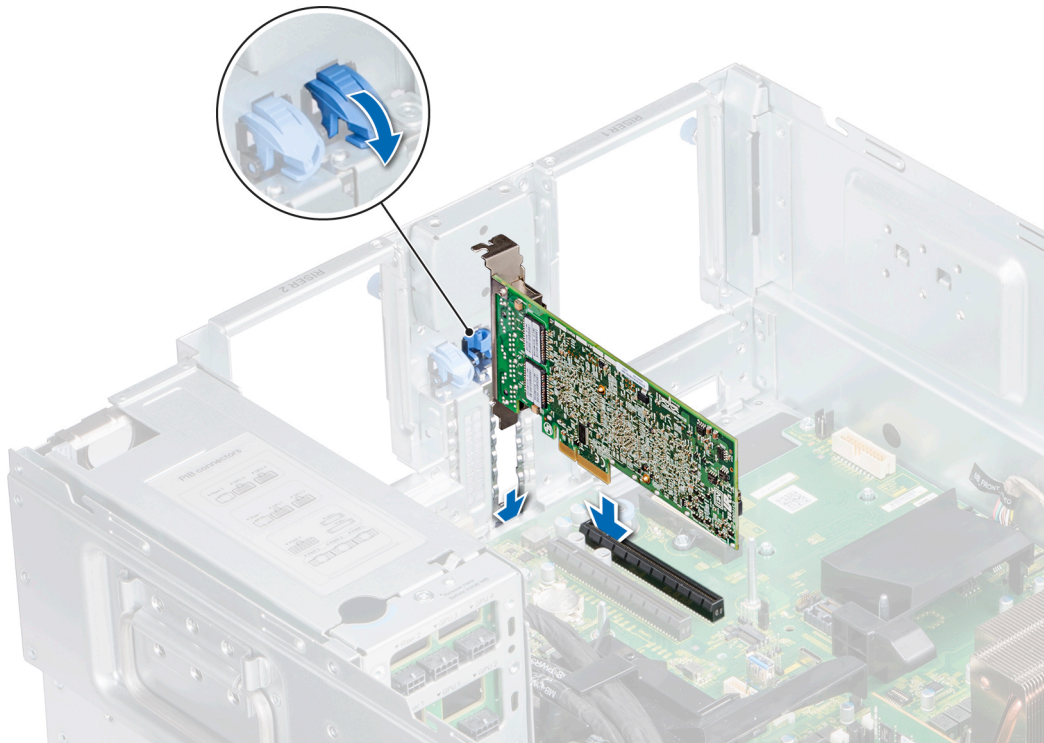

Figure 92. Removing a filler bracket from a riser



3. Holding the card on the edges, align the card with the expansion card connector on the system board.



**Figure 93. Installing the expansion card**

4. Press the expansion card firmly until the card is fully seated.
5. Push the blue expansion card retention latch until the latch snaps into place.
6. Disconnect the cables from the Power Interposer Board (PIB), system board, and the backplane.

**NOTE:** Ensure that you remove the cables that are secured using the cable securing bracket routed along the chassis wall.

**NOTE:** Remove the drive cable and the system board cables.

#### Next steps

1. [Replace the expansion card riser.](#)
2. [Replace the air shrouds.](#)
3. [Replace the support bar.](#)
4. Follow the procedure listed in [After working inside your system.](#)

## GPU card installation guidelines

- Ensure that the processors are installed.
- To ensure adequate cooling when one or more GPUs are installed, the ambient inlet temperature is restricted to 30°C for CPU 150 W/8 C, 165 W/12 C, 200 W, 205 W. For more information, see Ambient temperature limitations in the Dell EMC PowerEdge R940xa Technical Specifications on the product documentation page.
- All GPUs must be of the same type and model.
- You can install a GPU card only in the X16 PCIe connector on the risers. The X8 PCIe connector on the risers do not support GPU cards.
- You can install up to four double-wide GPUs.
  - NOTE:** If you want to install two GPUs in the same riser, you need to discard the GPU blank.
- The [GPU shroud](#) must be removed before installing the GPU.
- Ensure that the fans are installed.

The GPU power cable has three connection methods as mentioned below:

 **NOTE:** If the GPU has only one power port, use a GPU power adapter converter to connect it to the GPU.

- 2x3 pin power connection for two single width GPUs
- 2x4 pin power connection for single double width GPU
- 2x3 pin and 2x4 pin power connection for single double width GPU

## Removing the GPU

### Prerequisites

1. Follow the safety guidelines listed in [Safety instructions](#).
2. Follow the procedure listed in [Before working inside your system](#).
3. [Remove the support bar](#).
4. [Remove the air shrouds](#).
5. [Remove the expansion card riser](#).
  -  **NOTE:** Store the filler bracket for future use. Filler brackets must be installed in empty expansion card slots to maintain Federal Communications Commission (FCC) certification of the system. The brackets also keep dust and dirt out of the system and aid in proper cooling and airflow inside the system.
6. Disconnect the GPU power cable, system board slimline cable, and the riser power cable.

### Steps

1. Open the expansion card latch and the card holder latch on the riser.
2. Press the release button.
3. Pull the cover upward.
4. Lift the cover.
5. Open the card retention latch.
6. Holding the card by its edges, press the release latch on the PCIe connector and lift the card from the connector on the riser.

 **CAUTION:** Ensure to disconnect the GPU power cable before removing the GPU from the system.

7. Remove the system board slimline cable from the cable holder on the riser.
8. Disconnect the GPU power cable from the GPU.
9. Remove the GPU from the riser.

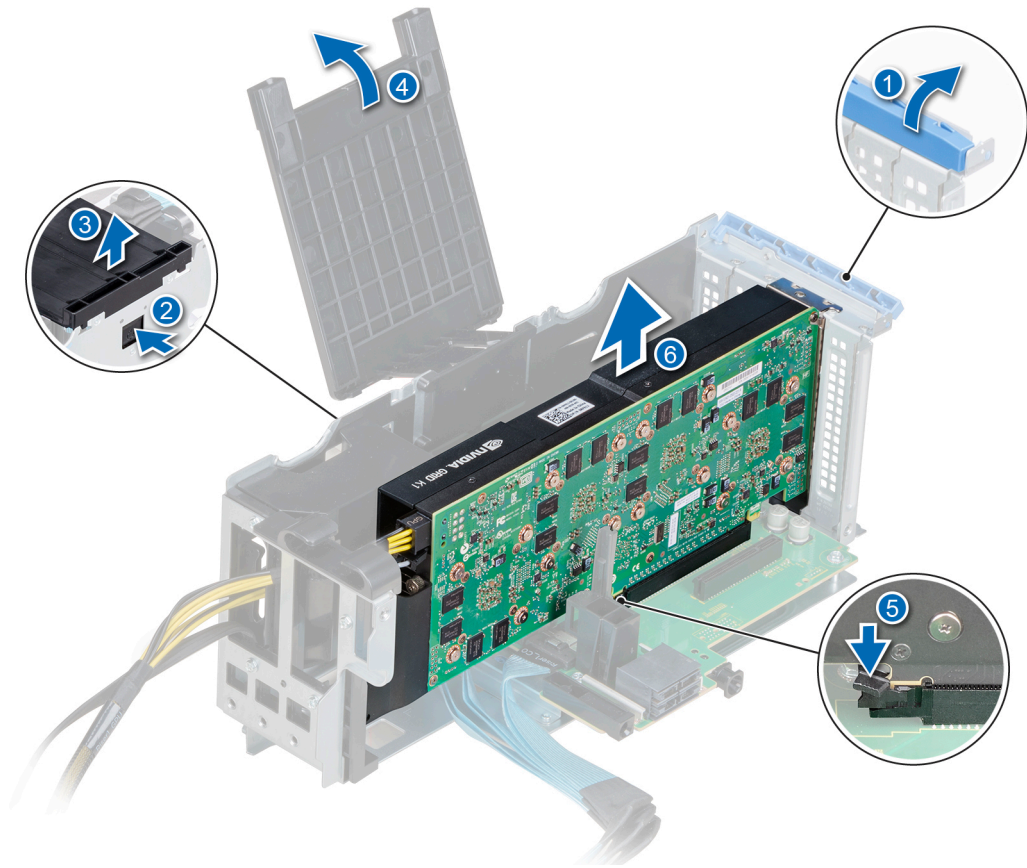

**Figure 94. Removing the GPU**

10. If you are removing the GPU permanently, install a filler bracket.

**i NOTE:** You must install a filler bracket over an empty expansion card slot to maintain Federal Communications Commission (FCC) certification of the system. The brackets also keep dust and dirt out of the system and aid in proper cooling and airflow inside the system. The filler bracket is necessary to maintain proper thermal conditions.

11. Remove the GPU blank.

12. Remove the GPU power cable and route it into the GPU blank.

13. Replace the GPU blank.

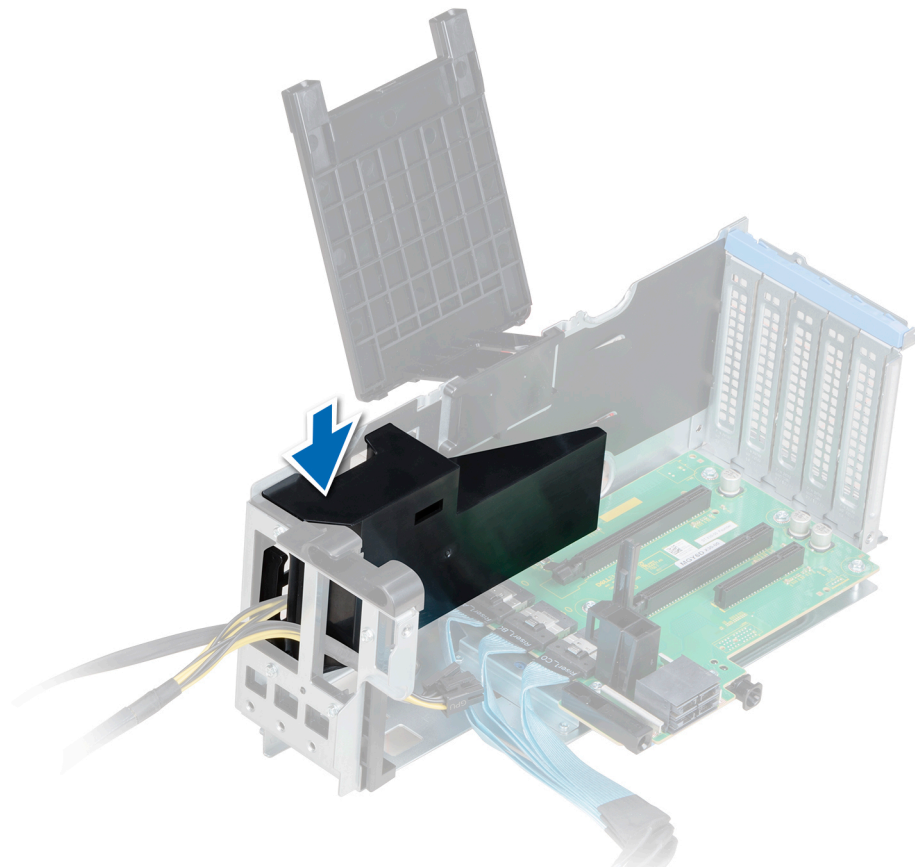

**Figure 95. Installing the GPU blank**

14. Close the cover.
15. Close the card retention latch by pushing the latch down until the latch snaps into place.

#### **Next steps**

Replace the GPU shroud.

## **Installing the GPU**

#### **Prerequisites**

- i** **NOTE:** The GPU card can be installed only in a X16 PCIe riser configuration.
  - i** **NOTE:** The GPU shroud must be removed only when a GPU is installed in the system.
1. Follow the safety guidelines listed in [Safety instructions](#).
  2. Follow the procedure listed in [Before working inside your system](#).
  3. If installing a new expansion card, unpack it and prepare the card for installation.
    - i** **NOTE:** For instructions, see the documentation accompanying the card.
  4. [Remove the support bar](#).
  5. [Remove the air shroud A](#).
  6. [Remove the expansion card riser](#), if you installing a GPU.
    - i** **NOTE:** Store the filler bracket for future use. Filler brackets must be installed in empty expansion card slots to maintain Federal Communications Commission (FCC) certification of the system. The brackets also keep dust and dirt out of the system and aid in proper cooling and airflow inside the system.

## Steps

1. Unpack the expansion card and prepare it for installation.

**i** **NOTE:** For instructions, see the documentation accompanying the card.

2. Press and slide the release button upward to lift the cover.
3. Open the card retention latch.
4. Remove the filler bracket from the expansion card holder.

**i** **NOTE:** Store the filler bracket for future use. Filler brackets must be installed in empty expansion card slots to maintain Federal Communications Commission (FCC) certification of the system. The brackets also keep dust and dirt out of the system and aid in proper cooling and airflow inside the system.

5. Connect the system board slimline cable to the ports on the expansion card riser.
6. Remove the GPU blank shroud.  
GPU ready - The GPU power cable is enclosed in the GPU blank

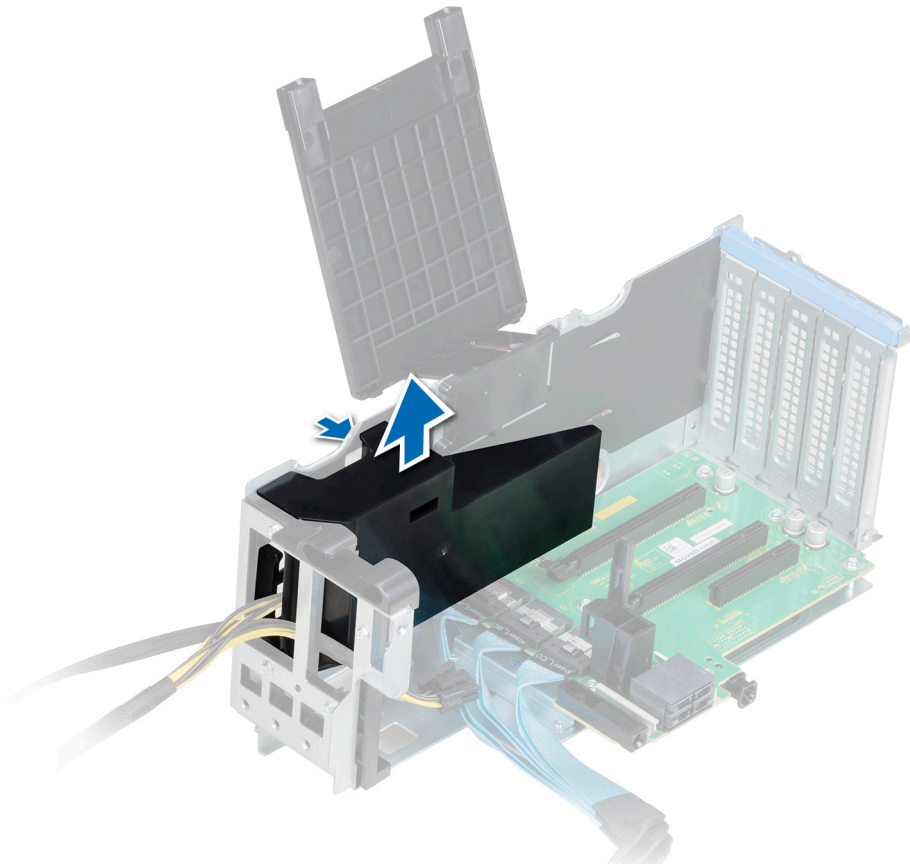

**Figure 96. Removing the GPU blank**

7. Remove the GPU power cable from the GPU blank and connect it to the GPU.
8. Align the GPU blank cover with the clips on the riser and push down until it latches onto the riser.
9. Holding the card by its edges, align the connectors on the GPU with the slots on the riser.
10. Insert the card firmly into the expansion card slot until the card is fully seated.
11. Connect the GPU power cable to the GPU.
12. Route the system board slimline cable through the cable holder on the riser.
13. Close the cover.
14. Close the card retention latch by pushing the latch down until the latch snaps into place.

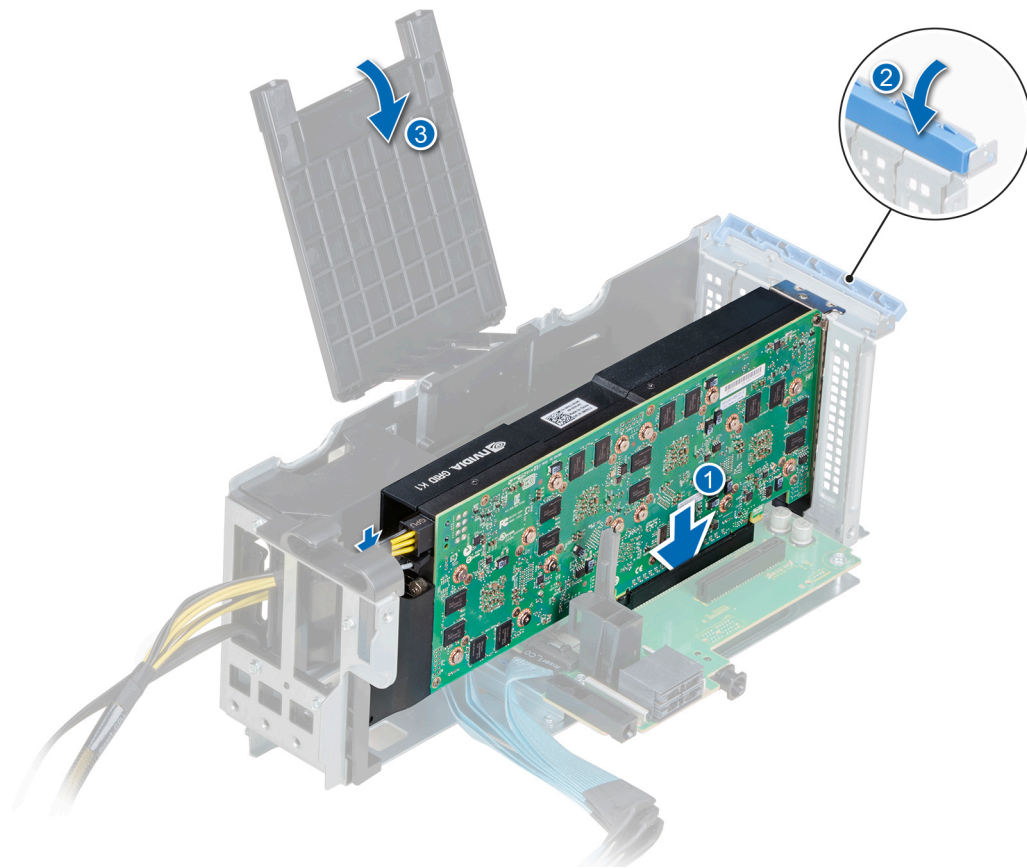

**Figure 97. Installing the GPU**

### Next steps

1. [Replace the expansion card riser.](#)
2. Connect the GPU power cable, system board slimline cable, and the riser power cable.
3. [Replace the air shrouds](#)
4. [Replace the support bar.](#)
5. Follow the procedure listed in [After working inside your system.](#)

## M.2 SSD module

The BOSS card is a simple RAID solution card designed specifically for booting the operating system. The card supports up to two 6 Gbps M.2 SATA drives. The BOSS adapter card has a x8 connector using PCIe gen 2.0 x2 lanes.

## Removing the M.2 BOSS module

### Prerequisites

1. Follow the safety guidelines listed in [Safety instructions.](#)
2. Follow the procedure listed in [Before working inside your system.](#)
3. [Remove the support bar.](#)
4. [Remove the air shrouds.](#)
5. [Remove the expansion riser card.](#)
6. Remove the BOSS card

**NOTE:** Removing the BOSS card is similar to the procedure for removing an expansion card riser.

## Steps

1. Loosen the screw and lift the retention straps that secure the M.2 BOSS module on the BOSS card.
2. Pull the M.2 BOSS module from the BOSS card.

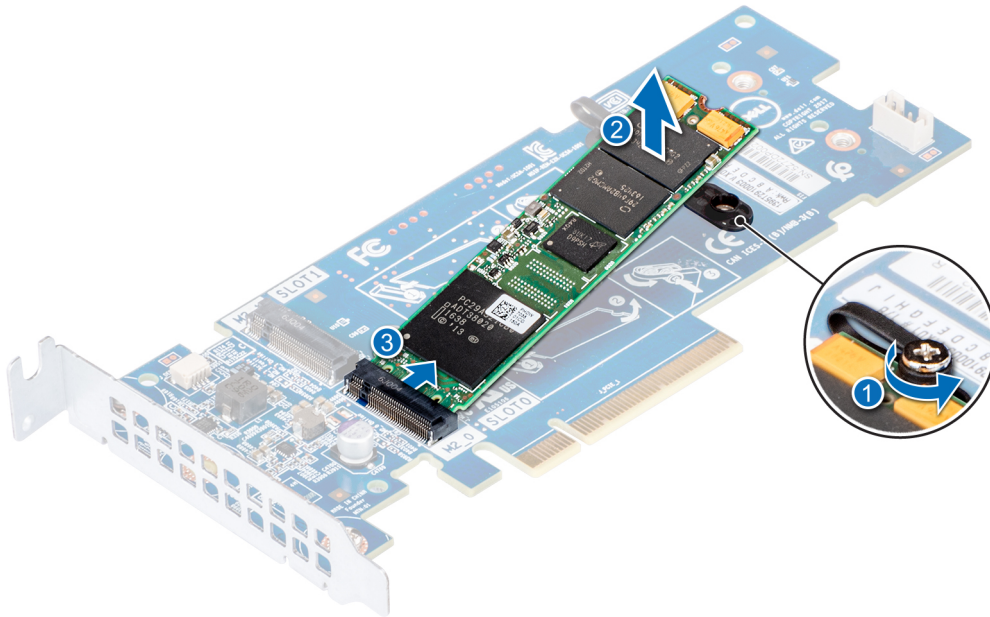

**Figure 98. Removing the M.2 BOSS module**

## Next steps

Replace the M.2 BOSS module.

## Installing the M.2 BOSS module

### Prerequisites

1. Follow the safety guidelines listed in [Safety instructions](#).
2. [Remove the support bar](#).
3. [Remove the air shrouds](#).
4. [Replace the expansion card riser](#).
5. Remove the BOSS card.

**NOTE:** Removing the BOSS card is similar to the procedure for removing an expansion card.

## Steps

1. Align the M.2 BOSS card at a 45 degree with the SATA connector on the M.2 BOSS module.
2. Press the M.2 BOSS card into the SATA connector until firmly seated.
3. Push the M.2 BOSS card down and using Phillips #1 screwdriver, secure the M.2 BOSS card to the module.

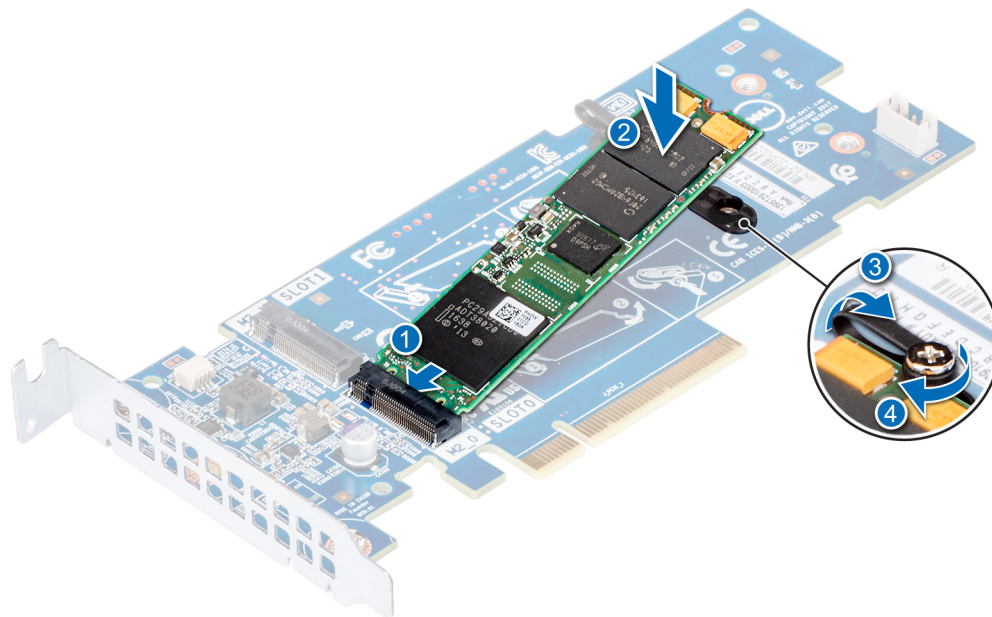

**Figure 99. Installing the M.2 BOSS module**

### Next steps

1. Replace the BOSS card.
  - i** **NOTE:** Replacing the BOSS card is similar to the procedure for installing an expansion card.
2. [Replace the expansion card riser.](#)
3. [Replace the air shrouds.](#)
4. [Replace the support bar.](#)
5. Follow the procedure listed in [After working inside your system.](#)

## Optional IDSDM or vFlash module

**i** **NOTE:** The write-protect switch is on the IDSDM or vFlash module.

## Removing the MicroSD card

### Prerequisites

1. Follow the safety guidelines listed in [Safety instructions.](#)
2. Follow the procedure listed in [Before working inside your system.](#)
3. [Remove the support bar.](#)
4. [Remove the air shrouds.](#)
5. [Remove the expansion card riser.](#)
6. [Remove the IDSDM or vFlash module.](#)

### Steps

1. Locate the MicroSD card slot on the IDSDM or vFlash module, and press the card to partially release it from the slot.
  - i** **NOTE:** Temporarily label each MicroSD card with its corresponding slot number after removal.
2. Hold the MicroSD card and remove it from the slot.



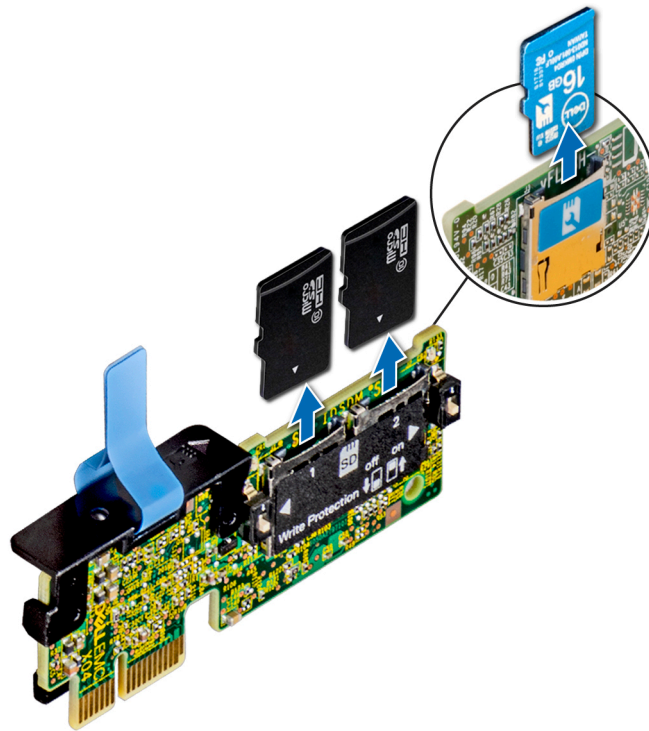

Figure 100. Removing the MicroSD card

#### Next steps

1. Replace the MicroSD card.

## Installing the MicroSD card

#### Prerequisites

1. Follow the safety guidelines listed in [Safety instructions](#).
2. Follow the procedure listed in [Before working inside your system](#).
3. [Remove the support bar](#).
4. [Remove the air shrouds](#).
5. [Remove the expansion card riser](#).
6. [Remove the IDSDM or vFlash module](#).

**NOTE:** To use an MicroSD card with your system, ensure that the **Internal SD Card Port** is enabled in System Setup.

#### Steps

1. Locate the MicroSD card connector on the IDSDM or vFlash module. Orient the MicroSD card appropriately and insert the contact-pin end of the card into the slot.

**NOTE:** Ensure that you install the MicroSD cards into the same slots based on the labels you had marked on the cards during removal.

2. Press the card into the card slot to lock it into place.

#### Next steps

1. [Replace the expansion card riser](#).
2. [Replace the air shrouds](#).
3. [Replace the support bar](#).
4. Follow the procedure listed in [After working inside your system](#).

## Removing the IDSDM or vFlash module

### Prerequisites

1. Follow the safety guidelines listed in [Safety instructions](#).
2. Follow the procedure listed in [Before working inside your system](#).
3. [Remove the support bar](#).
4. [Remove the air shrouds](#).
5. [Remove the expansion card riser](#).
6. [Remove the MicroSD cards](#), if you are replacing the IDSDM or vFlash module.
  - i** **NOTE:** Temporarily label each MicroSD card with its corresponding slot number after removal.

### Steps

1. Locate the IDSDM or vFlash connector on Riser 1.
2. Holding the pull tab, lift the IDSDM or vFlash module out of the system.

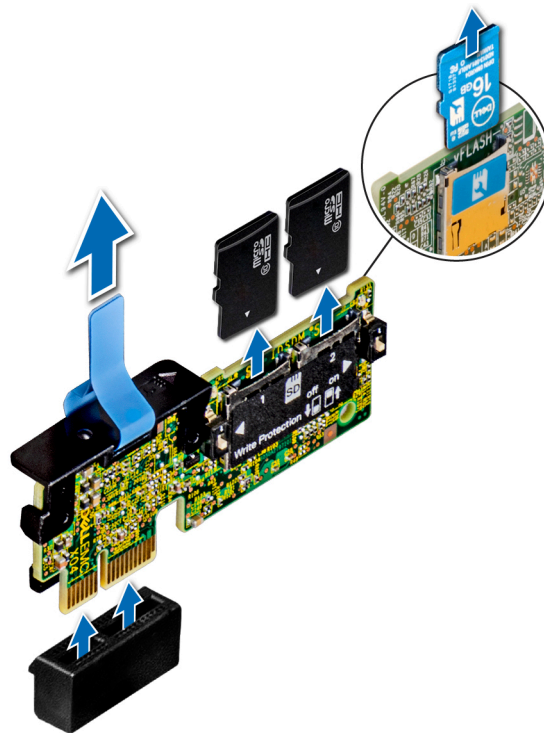

**Figure 101. Removing the IDSDM or vFlash module**

**i** **NOTE:** There are two dip switches on the IDSDM or vFlash module for write-protection.

**i** **NOTE:** If you are replacing the IDSDM or vFlash module, [remove the MicroSD cards](#).

### Next steps

1. [Replace the IDSDM or vFlash module](#).

## Installing the IDSDM or vFlash module

### Prerequisites

1. Follow the safety guidelines listed in [Safety instructions](#).
2. Follow the procedure listed in [Before working inside your system](#).
3. [Remove the support bar](#).

4. Remove the air shrouds.
5. Remove the expansion card riser.
6. Remove the MicroSD cards, if you are replacing the IDSDM or vFlash module.

**NOTE:** Temporarily label each MicroSD card with its corresponding slot number after removal.

### Steps

1. Locate the IDSDM or vFlash connector on Riser 1.
2. Align IDSDM or vFlash module with the connector on the riser.
3. Push IDSDM or vFlash module until it is firmly seated in the connector on the riser.

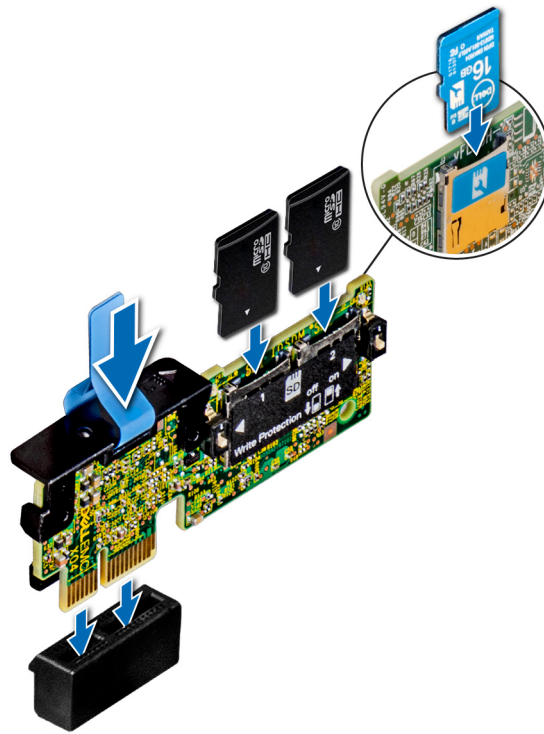

**Figure 102. Installing the IDSDM or vFlash module**

### Next steps

1. Replace the Micro SD cards
2. Replace the expansion card riser.
3. Replace the air shrouds.
4. Replace the support bar.
5. Follow the procedure listed in [After working inside your system](#).

## Network daughter card

The network daughter card (NDC) is a small, removable mezzanine card, which provides the flexibility of selecting different network connectivity options.

## Removing the network daughter card

### Prerequisites

1. Follow the safety guidelines listed in [Safety instructions](#).
2. Follow the procedure listed in [Before working inside your system](#).

3. Remove the support bar.
4. Remove the air shrouds.
5. Remove the expansion card riser 1.

### Steps

1. Using a Phillips #2 screwdriver, loosen the captive screws that secure the network daughter card (NDC) to the system board.
2. Hold the NDC by the edges, and lift to remove it from the connector on the system board.
3. Slide the NDC towards the front of the system until the ethernet connectors are clear of the slot in the back panel.
4. Lift the NDC out of the system.

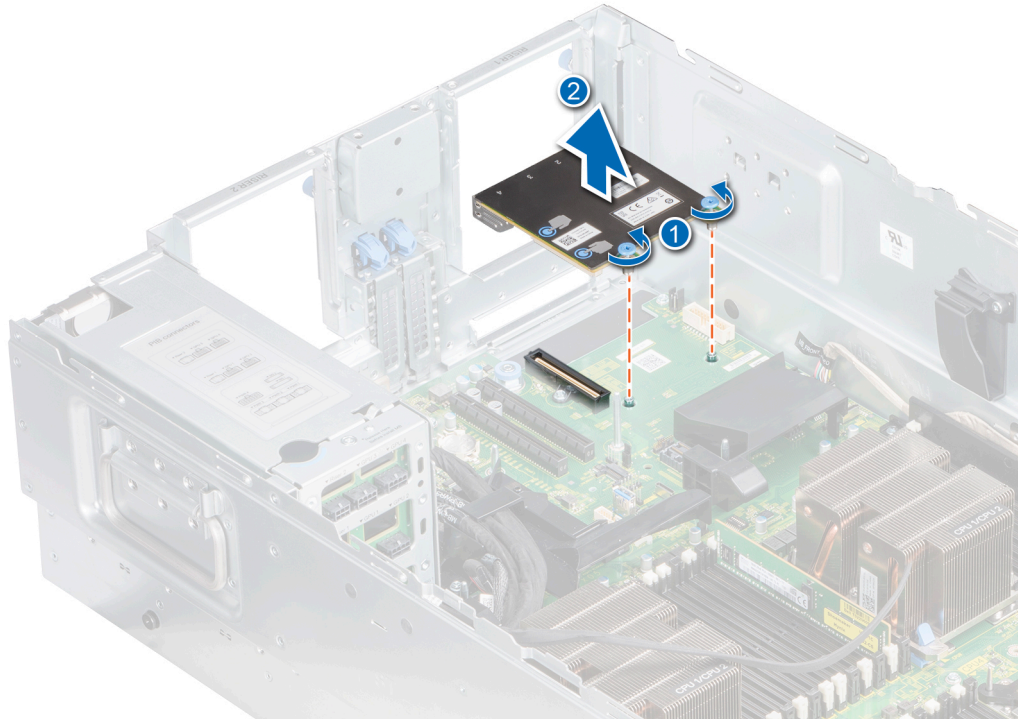

Figure 103. Removing network daughter card

### Next steps

1. Replace the network daughter card.

## Installing the network daughter card

### Prerequisites

1. Follow the safety guidelines listed in [Safety instructions](#).
2. Follow the procedure listed in [Before working inside your system](#).
3. [Remove the support bar](#).
4. [Remove the air shrouds](#).
5. [Remove the expansion card riser](#).

### Steps

1. Align the connectors on the NDC with the slots on the chassis.
2. Press the blue touch points until the card connector is firmly seated on the system board connector.
3. Using a Phillips #2 screwdriver, tighten the captive screws to secure the NDC to the system board.

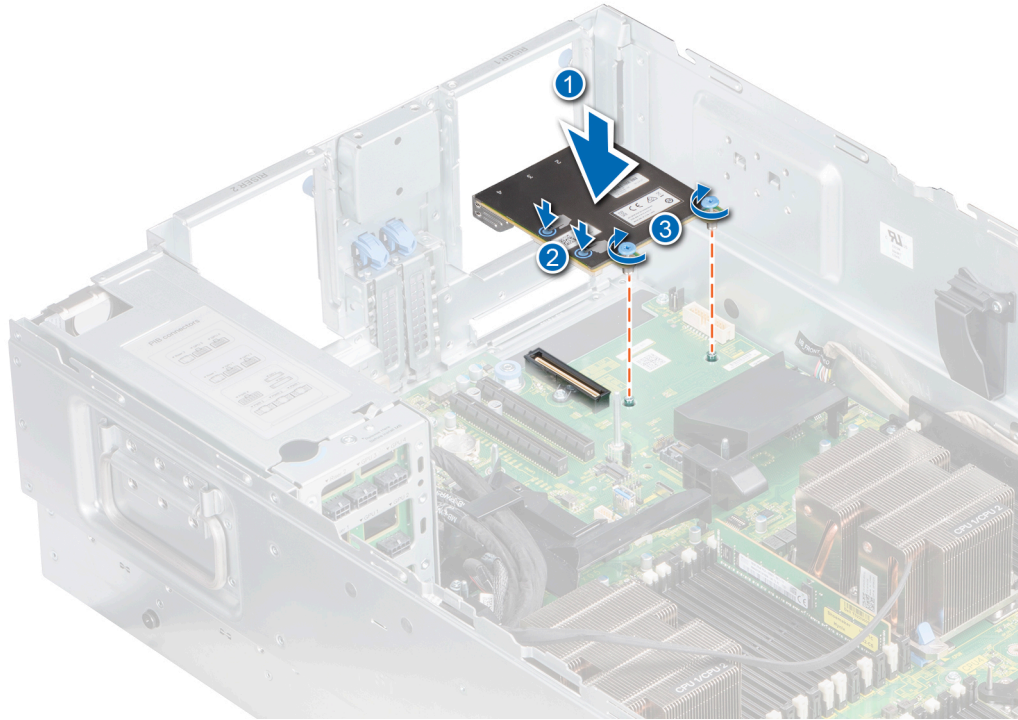

Figure 104. Installing the network daughter card

#### Next steps

1. [Replace the expansion card riser.](#)
2. [Replace the air shrouds](#)
3. [Replace the support bar.](#)
4. Follow the procedure listed in [After working inside your system.](#)

## System battery

The system battery is used for low-level system functions such as powering the real-time and date settings of the system.

## Replacing the system battery

#### Prerequisites

**⚠ WARNING:** There is a danger of a new battery exploding if it is incorrectly installed. Replace the battery only with the same or equivalent type recommended by the manufacturer. For more information, see the safety information that shipped with your system.

1. Follow the safety guidelines listed in [Safety instructions.](#)
2. Follow the procedure listed in [Before working inside your system.](#)
3. [Remove the support bar.](#)
4. [Remove the air shroud.](#)
5. [Remove the expansion card riser.](#)

#### Steps

1. Locate the battery socket. For more information, see [System board connectors.](#)

**CAUTION:** To avoid damage to the battery connector, you must firmly support the connector while installing or removing a battery.

2. Use a plastic scribe to pry out the system battery.



**Figure 105. Removing the system battery**

3. To install a new system battery, hold the battery with the positive side facing up and slide it under the securing tabs.
4. Press the battery into the connector until it snaps into place.

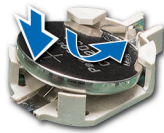

**Figure 106. Installing the system battery**

#### Next steps

1. [Replace the expansion card risers.](#)
2. [Replace the air shroud.](#)
3. [Replace the support bar.](#)
4. Follow the procedure listed in [After working inside your system.](#)
5. While booting, press F2 to enter the System Setup and ensure that the battery is operating properly.
6. Enter the correct time and date in the System Setup **Time** and **Date** fields.
7. Exit the System Setup.

## Optional internal USB memory key

An optional USB memory key installed inside your system can be used as a boot device, security key, or mass storage device. To boot from the USB memory key, configure the USB memory key with a boot image and then specify the USB memory key in the boot sequence in System Setup.

An optional USB memory key can be installed in the internal USB 3.0 port. The USB 3.0 module cable connects to the internal USB port on the system board. To locate the internal USB port, see the [system board connectors](#).

The internal USB memory key is supported only in the 8 x 2.5 inch hard-drive configuration.

## Replacing the optional internal USB memory key

#### Prerequisites

**CAUTION:** To avoid interference with other components in the server, the maximum permissible dimensions of the USB memory key are 15.9 mm wide x 57.15 mm long x 7.9 mm high.

1. Follow the safety guidelines listed in [Safety instructions](#).

2. Follow the procedure listed in [Before working inside your system](#).
3. [Remove the air shrouds](#).

### Steps

1. Locate the USB port or USB memory key on the system board.  
To locate the USB port, see [System board connectors](#).
2. If installed, remove the USB memory key from the USB port.
3. Insert the replacement USB memory key into the USB port.

### Next steps

1. [Install the air shrouds](#).
2. Follow the procedure listed in [after working inside your system](#).
3. While booting, press F2 to enter **System Setup** and verify that the system detects the USB memory key.

## Power supply units

The power supply unit (PSU) is an internal hardware component which supplies power to the components in the system.

Your system supports one of the following:

- Four 2400 W, 2000 W, 1600 W, or 1100 W, 750 W AC PSUs
- Four 750 W DC PSUs (for China only)
- Four 1100 W DC PSUs
- Four 1100 W or 750 W (for China only) Mixed Mode HVDC PSUs

 **NOTE:** For more information, see the Dell EMC PowerEdge R940xa Technical Specifications on the product documentation page.

 **CAUTION:** If multiple PSUs are installed, both the PSUs must have the same type of label. For example, **Extended Power Performance (EPP) label. Mixing PSUs from previous generations of PowerEdge servers is not supported, even if the PSUs have the same power rating. Mixing PSUs will result in mismatch condition or failure to turn the system on.**

 **NOTE:** Titanium PSU is nominally rated for 200 V AC to 240 V AC input only.

 **NOTE:** When identical PSUs are installed, power supply redundancy (2+2 – with redundancy or 4+0 – without redundancy) is configured in system BIOS. In redundant mode, power is supplied to the system equally from both PSUs when Hot Spare is disabled. When Hot Spare is enabled, one of the PSUs is put into the sleep mode when system utilization is low in order to maximize efficiency.

 **NOTE:** If multiple PSUs are used, they must be of the same maximum output power.

## Hot spare feature

 **NOTE:** Before removing the power supply, ensure that your system is configured with a hot spare power supply.

 **NOTE:** Ensure to check, if the system has multiple hot spare power supplies installed in it.

## Removing a power supply unit blank

### Prerequisites

Follow the safety guidelines listed in [Safety Instructions](#).

## Steps

If you are installing an additional PSU, remove the PSU blank in the bay by pulling the blank outward.

**CAUTION:** To ensure proper system cooling, the PSU blank must be installed in the empty PSU bays in a non-redundant configuration. Remove the PSU blank only if you are installing a PSU.

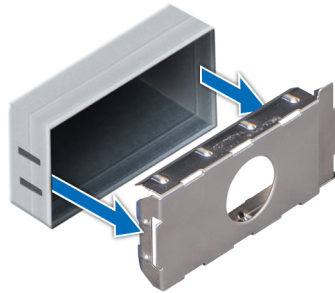

Figure 107. Removing a power supply unit blank

## Next steps

1. Replace the PSU or the PSU blank.

## Installing the power supply unit blank

### Prerequisites

1. Follow the safety guidelines listed in [Safety instructions](#).
2. Install the power supply unit (PSU) blank in the available PSU bay.

## Steps

Align the PSU blank with the PSU slot and push it into the PSU slot until it clicks into place.

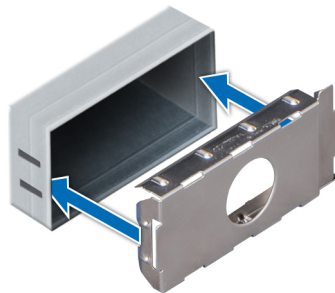

Figure 108. Installing the power supply unit blank

## Removing a power supply unit

The procedure for removing AC and DC PSUs is identical.

### Prerequisites

**CAUTION:** The system needs one power supply unit (PSU) for normal operation. On power-redundant systems, remove and replace only one PSU at a time in a system that is powered on.

1. Follow the safety guidelines listed in [Safety instructions](#).
2. Disconnect the power cable from the power source and from the PSU you intend to remove, and then remove the cable from the strap on the PSU handle.



3. Remove the optional strain relief bar and bracket if it interferes with the PSU removal.

For information about the strain relief bar and bracket, see the *Rail Installation Guide* at <https://www.dell.com/poweredgemanuals>.

### Steps

1. Press the orange release latch.
2. Slide the PSU out of the system by using the PSU handle.

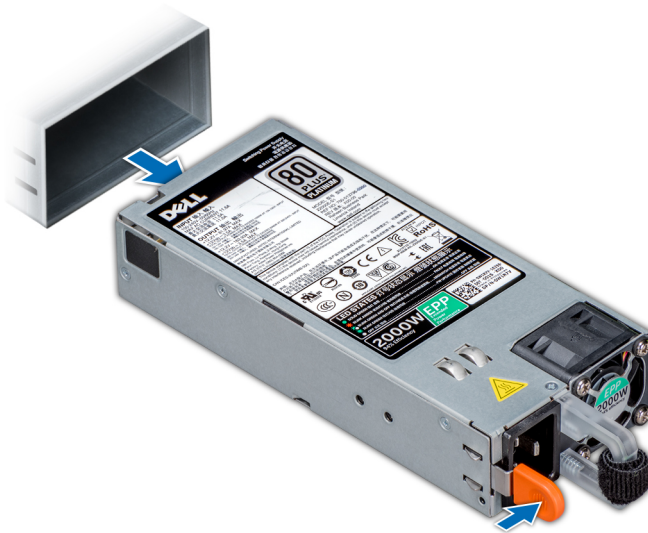

**Figure 109. Removing a power supply unit**

### Next steps

1. [Replace the PSU](#) or the [PSU blank](#).

## Installing the power supply unit

### Prerequisites

1. Follow the safety guidelines listed in [Safety instructions](#).
2. For systems that support redundant PSU, ensure that both the PSUs are of the same type and have the same maximum output power.

**NOTE:** The maximum output power (shown in watts) is listed on the PSU label.

### Steps

1. Slide the PSU into the system until the PSU is fully seated.
2. Release the latch to lock it into place.

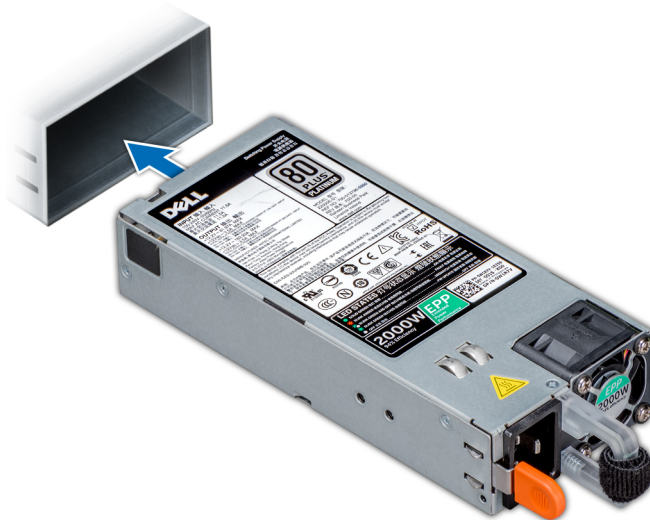

Figure 110. Installing the power supply unit

### Next steps

1. If you have removed the strain relief bar and bracket, replace them. For information about the strain relief bar and bracket, see the *Rail Installation Guide* at [Dell.com/poweredgemanuals](https://Dell.com/poweredgemanuals).
2. Connect the power cable to the PSU, and plug the cable into a power outlet.

**CAUTION:** When connecting the power cable to the PSU, secure the cable to the PSU with the strap.

**NOTE:** When installing, hot swapping, or hot adding a new PSU, wait for 15 seconds for the system to recognize the PSU and determine its status. The PSU redundancy may not occur until discovery is complete. Wait until the new PSU is discovered and enabled before you remove the other PSU. The PSU status indicator turns green to signify that the PSU is functioning properly.

3. Follow the procedure listed in [After working inside your system](#).

## Wiring instructions for a DC power supply unit

Your system supports up to two  $-(48-60)$  V DC power supply units (PSUs).

**NOTE:** For equipment using  $-(48-60)$  V DC power supply units (PSUs), a qualified electrician must perform all connections to DC power and to safety grounds. Do not attempt connecting to DC power or installing grounds yourself. All electrical wiring must comply with applicable local or national codes and practices. Damage due to servicing that is not authorized by Dell is not covered by your warranty. Read and follow all safety instructions that came with the product.

**CAUTION:** Wire the unit with copper only, unless otherwise specified, use only 10 American Wire Gauge (AWG) wire rated minimum  $90^{\circ}\text{C}$  for source and return. Protect the  $-(48-60)$  V DC (1 wire) with a branch circuit over-current protection rated 50 A for DC with a high interrupt current rating.

**CAUTION:** Connect the equipment to a  $-(48-60)$  V DC supply source that is electrically isolated from the AC source (reliably grounded  $-(48-60)$  V DC SELV source). Ensure that the  $-(48-60)$  V DC source is efficiently secured to earth (ground).

**NOTE:** A readily accessible disconnect device that is suitably approved and rated shall be incorporated in the field wiring.

## Input requirements

- Supply voltage:  $-(48-60)$  V DC

- Current consumption: 32 A (maximum)

## Kit contents

- Dell part number 6RYJ9 terminal block or equivalent (1)
- #6-32 nut equipped with lock washer (1)

## Required tools

Wire-stripper pliers capable of removing insulation from size 10 AWG solid or stranded, insulated copper wire.

 **NOTE:** Use alpha wire part number 3080 or equivalent (65/30 stranding).

## Required wires

- One UL 10 AWG, 2 m maximum (stranded) black wire [–(48–60) V DC].
- One UL 10 AWG, 2 m maximum (stranded) red wire (V DC return).
- One UL 10 AWG, 2 m maximum, green with a yellow stripe, stranded wire (safety ground).

# Power interposer board

## Removing the power interposer board

### Prerequisites

1. Follow the safety guidelines listed in [Safety instructions](#).
2. Follow the procedure listed in [Before working inside your system](#).
3. [Remove the support bar](#).
4. [Remove the air shrouds](#).
5. [Remove the power supply units](#).
6. [Remove the expansion card riser 2](#).

### Steps

1. Use Phillips #2 screwdriver to loosen the captive screw that secures the power interposer board (PIB).
2. Disconnect the cables connected from the power interposer board (PIB) to the system board.

 **NOTE:** Observe the routing of the cable as you remove it from the system. Route the cable properly when you replace it to prevent the cable from being pinched or crimped.

3. Hold the touch point firmly, and slide the power interposer board up and lift it out of the system.

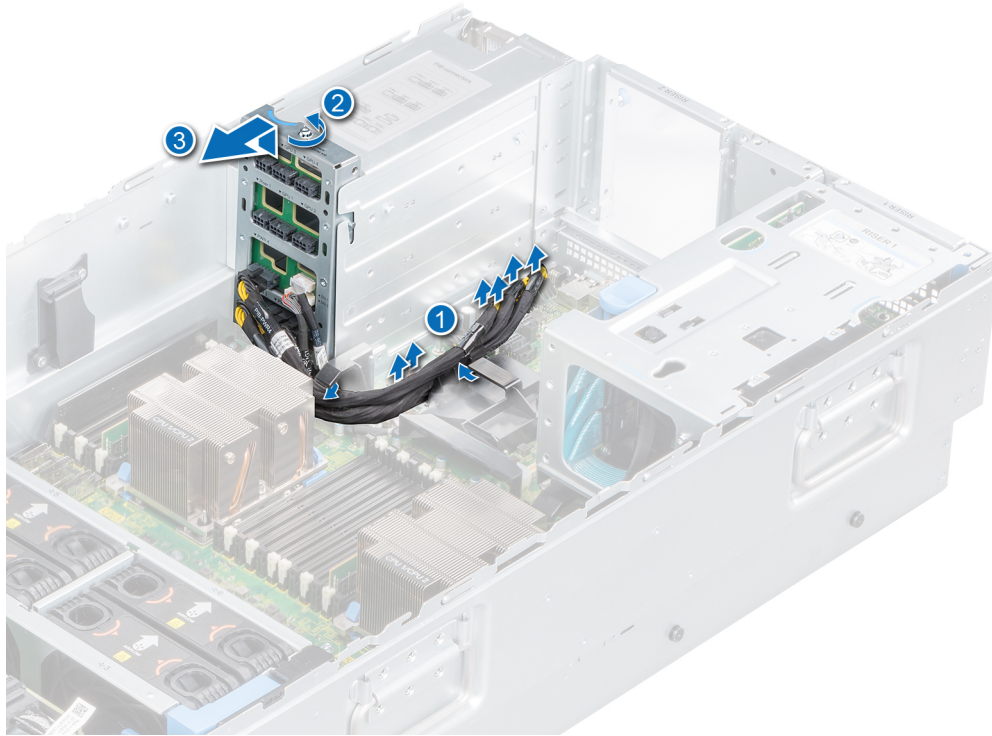

**Figure 111. Removing the power interposer board**

### Next steps

1. [Replace the power interposer board.](#)

## Installing the power interposer board

### Prerequisites

1. Follow the safety guidelines listed in [Safety instructions](#).
2. [Remove the support bar.](#)
3. [Remove the air shrouds.](#)
4. [Remove the power supply units.](#)
5. [Remove the expansion card risers 2.](#)

**i** **NOTE:** Observe the routing of the cable as you remove it from the system. Route the cable properly when you replace it to prevent the cable from being pinched or crimped.

### Steps

1. Align and slide the power interposer board into the PSU slot until it is firmly seated.
2. Use Phillips #2 screwdriver to tighten the captive screw that secures the power interposer board (PIB).

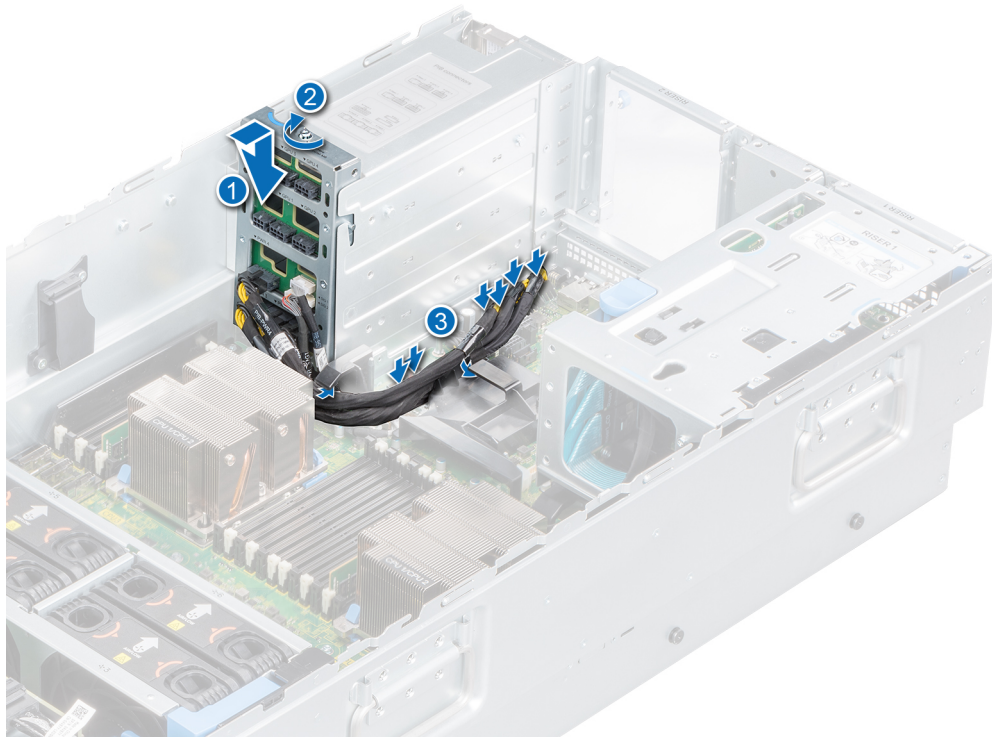

**Figure 112. Installing the power interposer board**

3. Route the cables in the retention tabs.
4. Connect the Power Interposer Board cables.
5. Connect the power cables to the system board and the hard drive backplane.

#### **Next steps**

1. [Replace the expansion card riser 2.](#)
2. [Replace the power supply units](#)
3. [Replace the air shrouds](#)
4. [Replace the support bar.](#)
5. Follow the procedure listed in [After working inside your system.](#)

## **Trusted Platform Module**

Trusted Platform Module (TPM) is a dedicated microprocessor designed to secure hardware by integrating cryptographic keys into devices. Software can use a TPM to authenticate hardware devices. Because each TPM chip has a unique and secret RSA key which is embedded during the manufacture of the TPM, it is capable of performing platform authentication operation.

## **Upgrading the Trusted Platform Module**

#### **Prerequisites**

##### **NOTE:**

- Ensure that your operating system supports the version of the TPM module being installed.
- Ensure that you download and install the latest BIOS firmware on your system.
- Ensure that the BIOS is configured to enable UEFI boot mode.

### About this task

**CAUTION:** Once the TPM plug-in module is installed, it is cryptographically bound to that specific system board. Any attempt to remove an installed TPM plug-in module breaks the cryptographic binding, the removed TPM cannot be reinstalled or installed on another system board.

## Removing the TPM

### Steps

1. Locate the TPM connector on the system board.
2. Press to hold the module down and remove the screw using the security Torx 8-bit shipped with the TPM module.
3. Slide the TPM module out from its connector.
4. Push the plastic rivet away from the TPM connector and rotate it 90° counterclockwise to release it from the system board.
5. Pull the plastic rivet out of its slot on the system board.

## Installing the TPM

### Steps

1. To install the TPM, align the edge connectors on the TPM with the slot on the TPM connector.
2. Insert the TPM into the TPM connector such that the plastic rivet aligns with the slot on the system board.
3. Press the plastic rivet until the rivet snaps into place.
4. Replace the screw that secures the TPM to the system board.

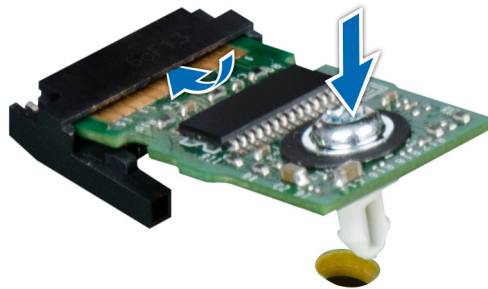

Figure 113. Installing the TPM

### Next steps

1. [Replace the system board.](#)
2. Follow the procedure listed in [After working inside your system.](#)
3. To verify if the memory module has been installed properly, press F2 and navigate to **System Setup Main Menu > System BIOS > Memory Settings**. In the **Memory Settings** screen, the System Memory Size must reflect the updated capacity of the installed memory.
4. If the value is incorrect, one or more of the memory modules may not be installed properly. Ensure that the memory module is firmly seated in the memory module socket.
5. Run the system memory test in system diagnostics.

## Initializing TPM for BitLocker users

### Steps

1. Initialize the TPM.  
For more information, see [initializing the TPM for Intel TXT users.](#)

2. The **TPM Status** changes to **Enabled, Activated**.

## Initializing the TPM 1.2 for TXT users

### Steps

1. While booting your system, press F2 to enter System Setup.
2. On the **System Setup Main Menu** screen, click **System BIOS > System Security Settings**.
3. From the **TPM Security** option, select **On with Preboot Measurements**.
4. From the **TPM Command** option, select **Activate**.
5. Save the settings.
6. Restart your system.
7. Enter **System Setup** again.
8. On the **System Setup Main Menu** screen, click **System BIOS > System Security Settings**.
9. From the **Intel TXT** option, select **On**.

## Initializing the TPM 2.0 for TXT users

### Steps



1. While booting your system, press F2 to enter System Setup.
2. On the **System Setup Main Menu** screen, click **System BIOS > System Security Settings**.
3. From the **TPM Security** option, select **On**.
4. Save the settings.
5. Restart your system.
6. Enter **System Setup** again.
7. On the **System Setup Main Menu** screen, click **System BIOS > System Security Settings**.
8. Select the **TPM Advanced Settings** option.
9. From the **TPM2 Algorithm Selection** option, select **SHA256**, then go back to **System Security Settings** screen.
10. On the **System Security Settings** screen, from the **Intel TXT** option, select **On**.
11. Save the settings.
12. Restart your system.

## System board

A system board (also known as the motherboard) is the main printed circuit board in the system with different connectors used to connect different components or peripherals of the system. A system board provides the electrical connections to the components in the system to communicate.

## Removing the System Board

### Prerequisites

-  **CAUTION:** If you are using the Trusted Platform Module (TPM) with an encryption key, you may be prompted to create a recovery key during program or System Setup. Be sure to create and safely store this recovery key. If you replace this system board, you must supply the recovery key when you restart your system or program before you can access the encrypted data on your drives.
-  **CAUTION:** Do not attempt to remove the TPM plug-in module from the system board. Once the TPM plug-in module is installed, it is cryptographically bound to that specific system board. Any attempt to remove an installed TPM plug-in module breaks the cryptographic binding, and it cannot be re-installed or installed on another system board.

1. Follow the safety guidelines listed in [Safety instructions](#).
2. Follow the procedure listed in [Before working inside your system](#).
3. Remove the following:
  - a. [Support bar](#)
  - b. [Air shrouds](#)
  - c. [Cooling fan assembly](#)
  - d. [Processor and heat sink module](#)
  - e. [Processor](#)
  - f. [Expansion card risers](#)
  - g. [Expansion cards](#)
  - h. [iDSDM/vFlash card](#)
  - i. [Internal USB key](#)
  - j. [USB 3.0 module](#)(if installed)
  - k. [Memory modules](#)
  - l. [Network daughter card](#)

### Steps

1. Disconnect all cables from the system board.

 **CAUTION:** Take care not to damage the system identification button while removing the system board from the system.

 **NOTE:** Do not remove the power interposer board cable from the risers.

 **CAUTION:** Do not lift the system board by holding a memory module, processor, or other components.

2. Pull the system board plungers and slide the system board towards the front of the system to release the system board from the chassis.
3. Incline the system board at an angle, and lift the system board out of the system.

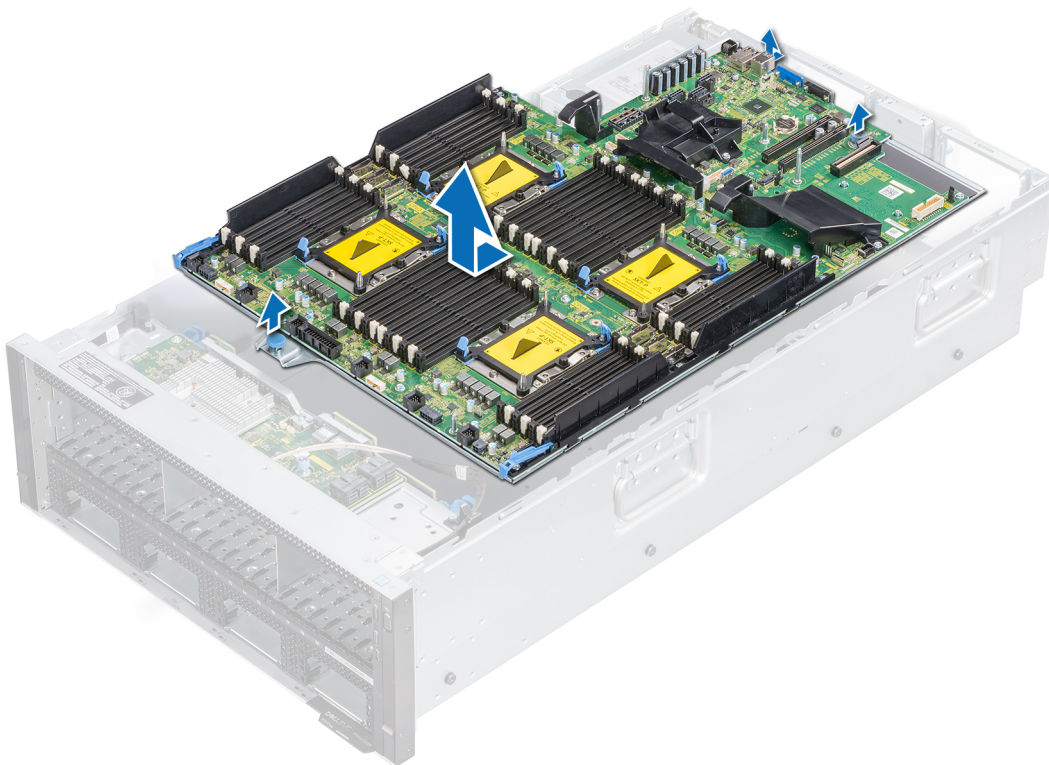

**Figure 114. Removing the system board**



## Next steps

1. [Install the system board.](#)

# Installing the system board

## Prerequisites

1. Follow the safety guidelines listed in [Safety instructions](#).
2. Follow the procedure listed in [Before working inside your system](#).

## Steps

1. Unpack the replacement system board assembly.

 **CAUTION:** Do not lift the system board by holding a memory module, processor, or other components.

 **CAUTION:** Take care not to damage the system identification button while placing the system board into the system.

2. Hold the system board plungers, incline the system board at an angle into the system.

 **NOTE:** If you are replacing the system board, remove all the components listed in the removing the system board section.

3. Align the connectors on the system board with the slots on the rear of the system chassis.

4. Slide the system board toward the rear of the system until the plungers click into place.

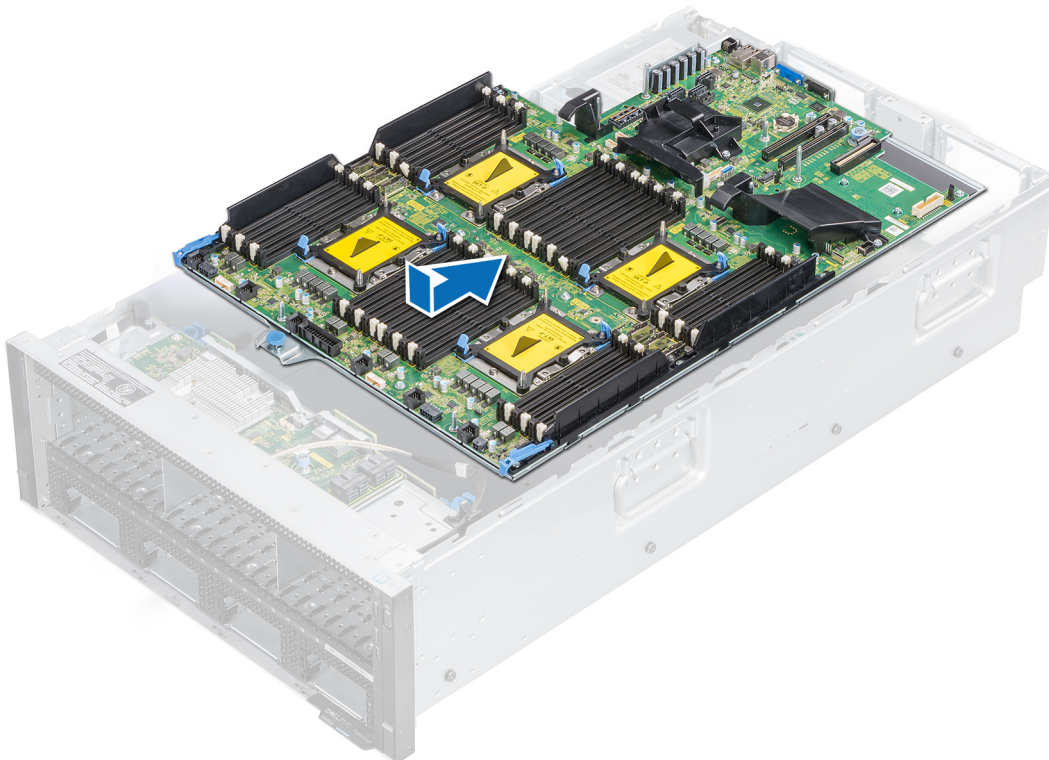

 **NOTE:** Before replacing the system board, ensure to replace the old iDRAC MAC address label in the Information tag with the iDRAC MAC address label of the replacement system board.



**Figure 115. Installing the system board**

## Next steps

1. Replace the following:

- a. [Trusted platform module](#)
    -  **NOTE:** The TPM Module must be replaced only while installing new system board.
    -  **NOTE:** The TPM plug-in module is attached to the system board and cannot be removed. A replacement TPM plug-in module is provided for all system board replacements where a TPM plug-in module was installed.
  - b. [Network daughter card](#)
  - c. [USB 3.0 module](#)
  - d. [iDSDM/vFlash card](#)
  - e. [Expansion cards](#)
  - f. [Expansion card risers](#)
  - g. [Processor](#)
  - h. [Processor and heat sink unit](#)
  - i. [Cooling fan assembly](#)
  - j. [Air shrouds](#)
  - k. [Support bar](#)
  - l. Reconnect the cables to the system board
2. Replace the iDRAC MAC address label from the luggage tag on the front of the system with the new iDRAC MAC address label that came with the replacement system board.
  3. Reconnect all cables to the system board.
    -  **NOTE:** Ensure that the cables inside the system are routed along the chassis wall and secured using the cable securing bracket.
  4. Boot the system.
  5. Follow the procedure listed in [After working inside your system](#).
  6. Ensure that you:
    - a. Use the Easy Restore feature to restore the Service Tag. For more information, see [Restoring the Service Tag using Easy Restore](#).
    - b. If the Service Tag is not backed up in the backup flash device, enter the Service Tag manually. For more information, see [Manually update the Service Tag](#).
    - c. Update the BIOS and iDRAC versions.
    - d. Re-enable the Trusted Platform Module (TPM). For more information, see [Upgrading the Trusted Platform Module \(TPM\)](#).
  7. Import your new or existing iDRAC Enterprise license.
 



For more information, see iDRAC User's Guide, at [www.dell.com/idracmanuals](http://www.dell.com/idracmanuals).

## Restore the service tag using Easy Restore

The Easy Restore feature allows you to restore your Service Tag, iDRAC license, UEFI configuration, and the system configuration data after replacing the system board. All data is backed up automatically in a backup flash drive device. If BIOS detects a new system board, and the Service Tag in the backup Flash device is different, BIOS prompts the user to restore the backup information.

### About this task

Following is a list of options available:

1. Restore the Service Tag, iDRAC license, and diagnostics information, press **Y**.
  2. Navigate to the Lifecycle Controller based restore options, press **N**.
  3. Restore data from a previously created **Hardware Server Profile**, press **F10**.
    -  **NOTE:** When the restore process is complete, BIOS prompts to restore the system configuration data.
  4. To restore the system configuration data, press **Y**
  5. To use the default configuration settings, press **N**
    -  **NOTE:** After the restore process is complete, system reboots.
-  **NOTE:** If restoring the Service Tag is successful, you can check the Service Tag information in the **System Information** screen and compare it with the Service Tag on the system.

## Manually updating Service Tag

After replacing a system board, if Easy Restore fails, follow this process to manually enter the Service Tag, using **System Setup**.

### About this task

If you know the system Service Tag, use the **System Setup** menu to enter the Service Tag.

### Steps

1. Turn on the system.
2. To enter the **System Setup**, press **F2**.
3. Click **Service Tag Settings**.
4. Enter the Service Tag.

 **NOTE:** You can enter the Service Tag only when the **Service Tag** field is empty. Ensure that you enter the correct Service Tag. After the Service Tag is entered, it cannot be updated or changed.

5. Click **OK**.

# Jumpers and connectors

This topic provides specific information about the jumpers. It also provides some basic information about jumpers and switches and describes the connectors on the various boards in the system. Jumpers on the system board help to disable the system and setup passwords. You must know the connectors on the system board to install components and cables correctly.

**Topics:**

- [System board connectors](#)
- [System board jumper settings](#)
- [Disabling a forgotten password](#)

# System board connectors

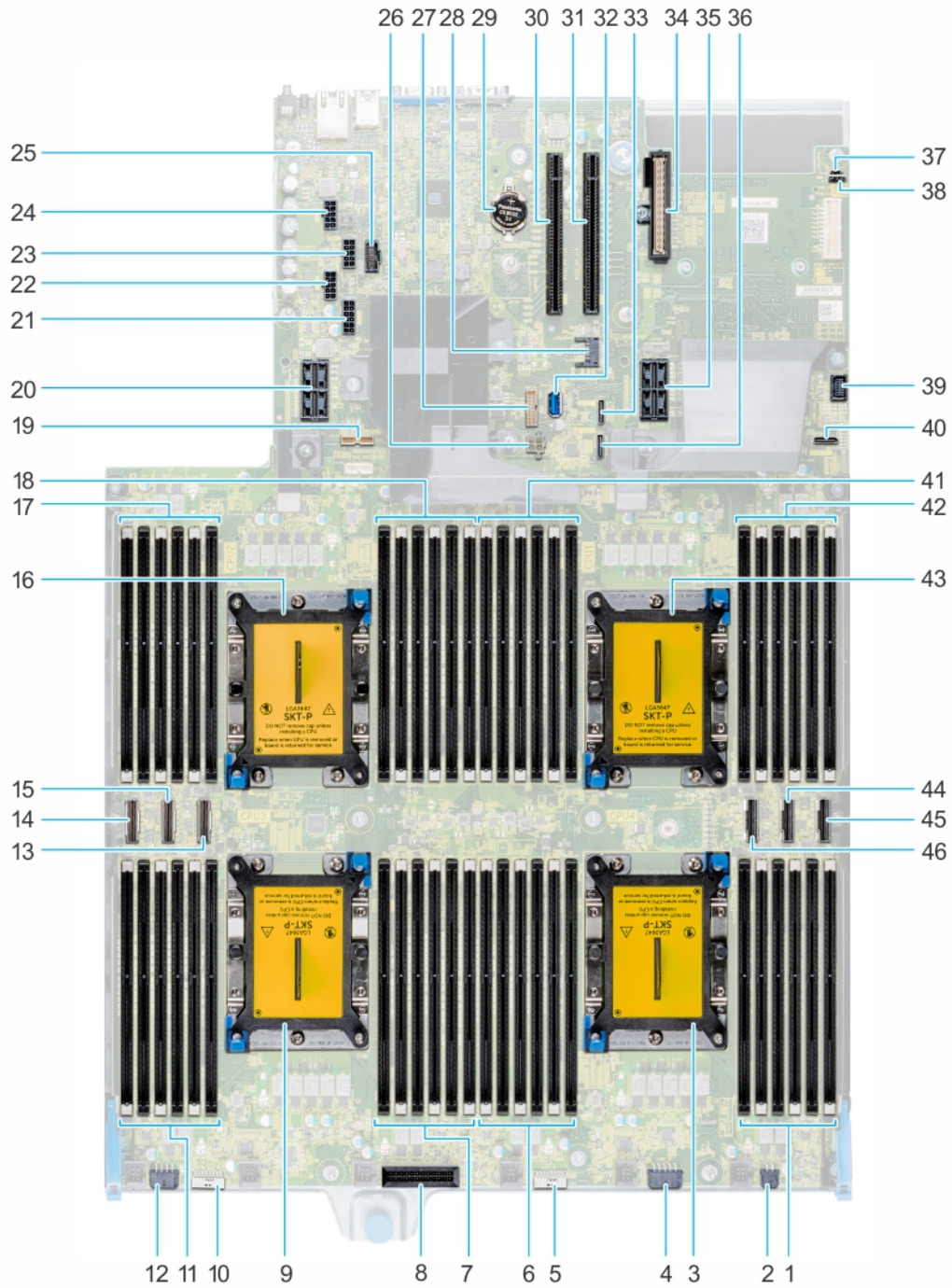

Figure 116. System board connectors

Table 20. System board connectors

Item	Connector	Description
1	D7, D1, D8, D2, D9, D3	Memory module sockets for CPU 4 DIMMs — Channels 0/1/2
2	J_ODD	Optical drive power connector
3	CPU4	CPU 4 processor and heat sink module socket—with dust cover
4	J_BP_PWR0	Backplane B power connector

**Table 20. System board connectors (continued)**

Item	Connector	Description
5	J_BP_SIG1	Backplane B signal connector (rear)
6	D6, D12, D5, D11, D4, D10	Memory module sockets for CPU 4 DIMMs — Channels 3/4/5
7	C7, C1, C8, C2, C9, C3	Memory module sockets for CPU 3 DIMMs — Channels 0/1/2
8	J_FAN4U_4	Cooling fan 4 connector
9	CPU3	CPU 3 processor and heat sink module socket—with dust cover
10	J_BP2	Backplane A signal connector (front)
11	C6, C12, C5, C11, C4, C10	Memory module sockets for CPU 3 DIMMs — Channels 3/4/5
12	J_BP_PWR1	Backplane A power connector
13	SATA A	PCIe signal M3
14	SATA B	PCIe signal M1
15	SATA C	PCIe signal M2
16	CPU2	CPU 2 processor and heat sink module socket—with dust cover
17	B3, B9, B2, B8, B1, B7	Memory module sockets for CPU 2 DIMMs — Channels 0/1/2
18	B10, B4, B11, B5, B12, B6	Memory module sockets for CPU 2 DIMMs — Channels 3/4/5
19	J_PIB_SIG1	Power Interposer Board signal connector 1
20	J_RISER2	PCIe riser 2 connector
21	J_PIB_PWR 4	Power Interposer Board power connector 4
22	J_PIB_PWR 3	Power Interposer Board power connector 3
23	J_PIB_PWR 2	Power Interposer Board power connector 2
24	J_PIB_PWR 1	Power Interposer Board power connector 1
25	U_USB_RECONN	USB Client power management
26	J_BATT_PWR	NVDIMM battery power connector
27	J_BATT_SIG	NVDIMM battery signal connector
28	J_TPM_MODULE	TPM connector
29	CMOS Battery	CMOS coin cell battery connector
30	J_SLOT7	PCIe x16 connector — slot 7
31	J_SLOT6	PCIe x16 connector — slot 6
32	J_USB_INT	Internal USB connector
33	J_SATA_1	NPIO connector1 for x8 Backplane
34	J_NDC	Network daughter card connector
35	J_RISER1	PCIe riser 1 connector
36	J_SATA_2	NPIO connector 2 for x8 Backplane
37	J_PWRD_EN	Reset BIOS password
38	J_NVRAM_CLR	Clear NVRAM





**Table 20. System board connectors (continued)**

Item	Connector	Description
39	J_FRONT_VIDEO	Front video connector
40	J_SATA_3	SATA C connector—Optical drive SATA connector
41	A3, A9, A2, A8, A1, A7	Memory module sockets for CPU 1 DIMMs — Channels 0/1/2
42	A10, A4, A11, A5, A12, A6	Memory module sockets for CPU 1 DIMMs — Channels 3/4/5
43	CPU1	CPU 1 processor and heat sink module socket—with dust cover
44	SATA D	PCIe signal M5
45	SATA E	PCIe signal M4
46	SATA F	PCIe signal M6

## System board jumper settings

For information on resetting the password jumper to disable a password, see the Disabling a forgotten password section.

**Table 21. System board jumper settings**

Jumper	Setting	Description
PWRD_EN	 2 4 6 (default)	The BIOS password feature is enabled.
	 2 4 6	The BIOS password feature is disabled. iDRAC local access is unlocked at next AC power cycle. iDRAC password reset is enabled in F2 iDRAC settings menu.
NVRAM_CLR	 1 3 5 (default)	The BIOS configuration settings are retained at system boot.
	 1 3 5	The BIOS configuration settings are cleared at system boot.

**CAUTION:** Be careful when altering BIOS settings. The BIOS interface is designed for advanced users, you can change a setting that could prevent your computer from starting correctly and you could suffer a potential loss of data.

1. Turn off the system, including any attached peripherals, and disconnect the system from the electrical outlet.
2. Remove the system cover.
3. Move the jumper (NVRAM\_CLR) on the system board jumper from pins 3 and 5 to pins 1 and 3 and wait approximately 10 seconds. Move the 2-pin jumper (PWRD\_EN) plug from the password jumper to pins into the CMOS jumper.
4. Replace the jumper plug on pins 3 and 5.
5. Install the system cover. Plug in AC Power to the system and wait ten seconds for the CMOS to clear, reconnect the system to its electrical outlet and turn on the system, including any attached peripherals.

## Disabling a forgotten password

The system's software security features include a system password and a setup password. The password jumper enables these password features or disables them and clears any password(s) currently in use.

### Prerequisites

**CAUTION:** Many repairs may only be done by a certified service technician. You should only perform troubleshooting and simple repairs as authorized in your product documentation, or as directed by the online or

**telephone service and support team. Damage due to servicing that is not authorized by Dell is not covered by your warranty. Read and follow the safety instructions that are shipped with your product.**

### Steps

1. Turn off the system, including any attached peripherals, and disconnect the system from the electrical outlet.
2. Remove the system cover.
3. Move the jumper on the system board jumper from pins 4 and 6 to pins 2 and 4.
4. Install the system cover.

The existing passwords are not disabled (erased) until the system boots with the jumper on pins 2 and 4. However, before you assign a new system and/or setup password, you must move the jumper back to pins 4 and 6.

 **NOTE:** If you assign a new system and/or setup password with the jumper on pins 2 and 4, the system disables the new password(s) the next time it boots.

5. Reconnect the system to its electrical outlet and turn the system on, including any attached peripherals.
6. Turn off the system, including any attached peripherals, and disconnect the system from the electrical outlet.
7. Remove the system cover.
8. Move the jumper on the system board jumper from pins 2 and 4 to pins 4 and 6.
9. Install the system cover.
10. Reconnect the system to its electrical outlet and turn the system on, including any attached peripherals.
11. Assign a new system and/or setup password.



# System diagnostics and indicator codes

The diagnostic indicators on the system front panel display system status during system startup.







## Topics:

- Status LED indicators
- System health and system ID indicator codes
- iDRAC Quick Sync 2 indicator codes
- iDRAC Direct LED indicator codes
- NIC indicator codes
- Power supply unit indicator codes
- Drive indicator codes
- System diagnostics

## Status LED indicators

 **NOTE:** The indicators display solid amber if any error occurs.

**Table 22. Status LED indicators and descriptions**

Icon	Description	Condition	Corrective action
	Drive indicator	The indicator turns solid amber if there is a drive error.	<ul style="list-style-type: none"> <li>• Check the System Event Log to determine if the drive has an error.</li> <li>• Run the appropriate Online Diagnostics test. Restart the system and run embedded diagnostics (ePSA).</li> <li>• If the drives are configured in a RAID array, restart the system, and enter the host adapter configuration utility program.</li> </ul>
	Temperature indicator	The indicator turns solid amber if the system experiences a thermal error (for example, the ambient temperature is out of range or there is a fan failure).	<p>Ensure that none of the following conditions exist:</p> <ul style="list-style-type: none"> <li>• A cooling fan has been removed or has failed.</li> <li>• System cover, air shroud, memory module blank, or back filler bracket is removed.</li> <li>• Ambient temperature is too high.</li> <li>• External airflow is obstructed.</li> </ul> <p>If the problem persists, see <a href="#">Getting help</a>.</p>
	Electrical indicator	The indicator turns solid amber if the system experiences an electrical error (for example, voltage out of range, or a failed power supply unit (PSU) or voltage regulator).	<p>Check the System Event Log or system messages for the specific issue. If it is due to a problem with the PSU, check the LED on the PSU. Reseat the PSU.</p> <p>If the problem persists, see <a href="#">Getting help</a>.</p>
	Memory indicator	The indicator turns solid amber if a memory error occurs.	<p>Check the System Event Log or system messages for the location of the failed memory. Reseat the memory module.</p> <p>If the problem persists, see <a href="#">Getting help</a>.</p>
	PCIe indicator	The indicator turns solid amber if a PCIe card experiences an error.	<p>Restart the system. Update any required drivers for the PCIe card. Reinstall the card.</p> <p>If the problem persists, see <a href="#">Getting help</a>.</p> <p> <b>NOTE:</b> For more information about the supported PCIe cards, see <a href="#">Expansion card installation guidelines</a>.</p>

# System health and system ID indicator codes

The system health and system ID indicator is located on the left control panel of your system.



Figure 117. System health and system ID indicators

Table 23. System health and system ID indicator codes

Indicator code	Description
Solid blue	Indicates that the system is turned on, system is healthy, and system ID mode is not active. Press the system health and system ID button to switch to system ID mode.
Blinking blue	Indicates that the system ID mode is active. Press the system health and system ID button to switch to system health mode.
Solid amber	Indicates that the system is in fail-safe mode. If the problem persists, see the Getting help section.
Blinking amber	Indicates that the system is experiencing a fault. Check the System Event Log or the LCD panel, if available on the bezel, for specific error messages. For information about the event and error messages generated by the system firmware and agents that monitor system components, go to <a href="http://qrl.dell.com">qrl.dell.com</a> > <b>Look Up</b> > <b>Error Code</b> , type the error code, and then click <b>Look it up</b> .

# iDRAC Quick Sync 2 indicator codes

iDRAC Quick Sync 2 module (optional) is located on the left control panel of your system.



Figure 118. iDRAC Quick Sync 2 indicators

Table 24. iDRAC Quick Sync 2 indicators and descriptions

Indicator code	Description	Corrective action
Off (default state)	Indicates that the iDRAC Quick Sync 2 feature is turned off. Press the iDRAC Quick Sync 2 button to turn on the iDRAC Quick Sync 2 feature.	If the LED fails to turn on, reseal the left control panel flex cable and check. If the problem persists, see the <a href="#">Getting help</a> section.
Solid white	Indicates that iDRAC Quick Sync 2 is ready to communicate. Press the iDRAC Quick Sync 2 button to turn off.	If the LED fails to turn off, restart the system. If the problem persists, see the <a href="#">Getting help</a> section.
Blinks white rapidly	Indicates data transfer activity.	If the indicator continues to blink indefinitely, see the <a href="#">Getting help</a> section.
Blinks white slowly	Indicates that firmware update is in progress.	If the indicator continues to blink indefinitely, see the <a href="#">Getting help</a> section.
Blinks white five times rapidly and then turns off	Indicates that the iDRAC Quick Sync 2 feature is disabled.	Check if iDRAC Quick Sync 2 feature is configured to be disabled by iDRAC. If the problem persists, see the <a href="#">Getting help</a> section. For more information, see <i>Integrated Dell Remote Access Controller User's Guide</i> at <a href="https://www.dell.com/idracmanuals">https://www.dell.com/idracmanuals</a> or <i>Dell OpenManage Server Administrator User's Guide</i> at <a href="https://www.dell.com/openmanagemanuals">https://www.dell.com/openmanagemanuals</a> .

**Table 24. iDRAC Quick Sync 2 indicators and descriptions (continued)**

Indicator code	Description	Corrective action
Solid amber	Indicates that the system is in fail-safe mode.	Restart the system. If the problem persists, see the <a href="#">Getting help</a> section.
Blinking amber	Indicates that the iDRAC Quick Sync 2 hardware is not responding properly.	Restart the system. If the problem persists, see the <a href="#">Getting help</a> section.

## iDRAC Direct LED indicator codes

The iDRAC Direct LED indicator lights up to indicate that the port is connected and is being used as a part of the iDRAC subsystem.

You can configure iDRAC Direct by using a USB to micro USB (type AB) cable, which you can connect to your laptop or tablet. The following table describes iDRAC Direct activity when the iDRAC Direct port is active:

**Table 25. iDRAC Direct LED indicator codes**

iDRAC Direct LED indicator code	Condition
Solid green for two seconds	Indicates that the laptop or tablet is connected.
Flashing green (on for two seconds and off for two seconds)	Indicates that the laptop or tablet connected is recognized.
Turns off	Indicates that the laptop or tablet is unplugged.

## NIC indicator codes

Each NIC on the back of the system has indicators that provide information about the activity and link status. The activity LED indicator indicates if data is flowing through the NIC, and the link LED indicator indicates the speed of the connected network.

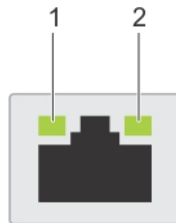

**Figure 119. NIC indicator codes**

1. Link LED indicator
2. Activity LED indicator

**Table 26. NIC indicator codes**

Status	Condition
Link and activity indicators are off.	The NIC is not connected to the network.
Link indicator is green, and activity indicator is blinking green.	The NIC is connected to a valid network at its maximum port speed, and data is being sent or received.
Link indicator is amber, and activity indicator is blinking green.	The NIC is connected to a valid network at less than its maximum port speed, and data is being sent or received.
Link indicator is green, and activity indicator is off.	The NIC is connected to a valid network at its maximum port speed, and data is not being sent or received.
Link indicator is amber, and activity indicator is off.	The NIC is connected to a valid network at less than its maximum port speed, and data is not being sent or received.

**Table 26. NIC indicator codes (continued)**

Status	Condition
Link indicator is blinking green, and activity is off.	NIC identify is enabled through the NIC configuration utility.

## Power supply unit indicator codes

AC power supply units (PSUs) have an illuminated translucent handle that serves as an indicator.

The DC PSUs have an LED that serves as an indicator.

For more information on the PSU specifications, see the Dell EMC PowerEdge R940xa Technical Specifications on the product documentation page.

For information about the event and error messages generated during POST, when a 2400W PSU is connected to a 110V power source, see the Dell Event and Error Messages Reference Guide at [www.dell.com/qrl](http://www.dell.com/qrl).

The indicator shows whether power is present or if a power fault has occurred.

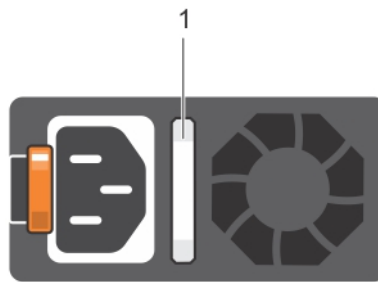

**Figure 120. AC PSU status indicator**

1. AC PSU status indicator/handle

**Table 27. AC PSU status indicator codes**

Power indicator codes	Condition
Green	A valid power source is connected to the PSU and the PSU is operational.
Blinking amber	Indicates a problem with the PSU.
Not illuminated	Power is not connected to the PSU.
Blinking green	When the firmware of the PSU is being updated, the PSU handle blinks green. <b>⚠ CAUTION: Do not disconnect the power cord or unplug the PSU when updating firmware. If firmware update is interrupted, the PSUs do not function.</b>
Blinking green and turns off	When hot-plugging a PSU, the PSU handle blinks green five times at a rate of 4 Hz and turns off. This indicates a PSU mismatch with respect to efficiency, feature set, health status, or supported voltage. <b>⚠ CAUTION: If two PSUs are installed, both the PSUs must have the same type of label; for example, Extended Power Performance (EPP) label. Mixing PSUs from previous generations of PowerEdge servers is not supported, even if the PSUs have the same power rating. This results in a PSU mismatch condition or failure to turn the system on.</b> <b>⚠ CAUTION: When correcting a PSU mismatch, replace only the PSU with the blinking indicator. Swapping the PSU to make a matched pair can result in an error condition and unexpected system shutdown. To change from a high output configuration to a low output configuration or vice versa, you must turn off the system.</b> <b>⚠ CAUTION: AC PSUs support both 240 V and 120 V input voltages with the exception of Titanium PSUs, which support only 240 V. When two identical PSUs receive different input voltages, they can output different wattages, and trigger a mismatch.</b>

**Table 27. AC PSU status indicator codes (continued)**

Power indicator codes	Condition
	<p><b>CAUTION:</b> If two PSUs are used, they must be of the same type and have the same maximum output power.</p> <p><b>CAUTION:</b> Combining AC and DC PSUs is not supported and triggers a mismatch.</p>

## Drive indicator codes

The LEDs on the drive carrier indicates the state of each drive. Each drive carrier in your system has two LEDs: an activity LED (green) and a status LED (bicolor, green/amber). The activity LED flashes whenever the drive is accessed.



**Figure 121. Drive indicators on the drive and the mid drive tray backplane**

1. Drive activity LED indicator
2. Drive status LED indicator
3. Drive capacity label

**NOTE:** If the drive is in the Advanced Host Controller Interface (AHCI) mode, the status LED indicator does not turn on.

**Table 28. Drive indicator codes**

Drive status indicator code	Condition
Flashes green twice per second	Identifying drive or preparing for removal.
Off	Drive ready for removal. <b>NOTE:</b> The drive status indicator remains off until all drives are initialized after the system is turned on. Drives are not ready for removal during this time.
Flashes green, amber, and then turns off	Predicted drive failure.
Flashes amber four times per second	Drive failed.
Flashes green slowly	Drive rebuilding.
Solid green	Drive online.
Flashes green for three seconds, amber for three seconds, and then turns off after six seconds	Rebuild stopped.

# System diagnostics

If you experience a problem with your system, run the system diagnostics before contacting Dell for technical assistance. The purpose of running system diagnostics is to test your system hardware without using additional equipment or risking data loss. If you are unable to fix the problem yourself, service and support personnel can use the diagnostics results to help you solve the problem.

## Dell Embedded System Diagnostics

 **NOTE:** The Dell Embedded System Diagnostics is also known as Enhanced Pre-boot System Assessment (ePSA) diagnostics.

The Embedded System Diagnostics provides a set of options for particular device groups or devices allowing you to:

- Run tests automatically or in an interactive mode
- Repeat tests
- Display or save test results
- Run thorough tests to introduce additional test options to provide extra information about the failed device(s)
- View status messages that inform you if tests are completed successfully
- View error messages that inform you of problems encountered during testing

## Running the Embedded System Diagnostics from Boot Manager

Run the Embedded System Diagnostics (ePSA) if your system does not boot.

### Steps

1. When the system is booting, press F11.
2. Use the up arrow and down arrow keys to select **System Utilities > Launch Diagnostics**.
3. Alternatively, when the system is booting, press F10, select **Hardware Diagnostics > Run Hardware Diagnostics**. The **ePSA Pre-boot System Assessment** window is displayed, listing all devices detected in the system. The diagnostics starts executing the tests on all the detected devices.

## Running the Embedded System Diagnostics from the Dell Lifecycle Controller

### Steps

1. As the system boots, press F10.
2. Select **Hardware Diagnostics → Run Hardware Diagnostics**. The **ePSA Pre-boot System Assessment** window is displayed, listing all devices detected in the system. The diagnostics starts executing the tests on all the detected devices.

## System diagnostic controls

Menu	Description
<b>Configuration</b>	Displays the configuration and status information of all detected devices.
<b>Results</b>	Displays the results of all tests that are run.
<b>System health</b>	Provides the current overview of the system performance.
<b>Event log</b>	Displays a time-stamped log of the results of all tests run on the system. This is displayed if at least one event description is recorded.

# Getting help

## Topics:

- [Contacting Dell](#)
- [Documentation feedback](#)
- [Accessing system information by using QRL](#)
- [Receiving automated support with SupportAssist](#)
- [Recycling or End-of-Life service information](#)

## Contacting Dell

Dell provides several online and telephone based support and service options. If you do not have an active internet connection, you can find contact information about your purchase invoice, packing slip, bill, or Dell product catalog. Availability varies by country and product, and some services may not be available in your area. To contact Dell for sales, technical assistance, or customer service issues:

### Steps

1. Go to [www.dell.com/support/home](http://www.dell.com/support/home)
2. Select your country from the drop-down menu on the lower right corner of the page.
3. For customized support:
  - a. Enter your system Service Tag in the **Enter your Service Tag** field.
  - b. Click **Submit**.  
The support page that lists the various support categories is displayed.
4. For general support:
  - a. Select your product category.
  - b. Select your product segment.
  - c. Select your product.  
The support page that lists the various support categories is displayed.
5. For contact details of Dell Global Technical Support:
  - a. Click [Contact Technical Support](#)
  - b. The **Contact Technical Support** page is displayed with details to call, chat, or e-mail the Dell Global Technical Support team.

## Documentation feedback

You can rate the documentation or write your feedback on any of our Dell EMC documentation pages and click **Send Feedback** to send your feedback.

## Accessing system information by using QRL

You can use the Quick Resource Locator (QRL) to get immediate access to the information about your system. The QRL is located on the top of the system cover and provides access to generic information about your system. If you want to access information specific to the system service tag, such as configuration and warranty, you can access QR code located on the system Information tag.

### Prerequisites

Ensure that your smart phone or tablet has the QR code scanner installed.

The QRL includes the following information about your system:

- How-to videos
- Reference materials, including the Owner's Manual, LCD diagnostics, and mechanical overview
- A direct link to Dell to contact technical assistance and sales teams

#### Steps

1. Go to [www.dell.com/qrl](http://www.dell.com/qrl) and navigate to your specific product or
2. Use your smart phone or tablet to scan the model-specific Quick Resource (QR) code on your PowerEdge system or in the Quick Resource Locator section.

## Quick Resource Locator for PowerEdge R940xa system



Figure 122. Quick Resource Locator for PowerEdge R940xa system

## Receiving automated support with SupportAssist

Dell EMC SupportAssist is an optional Dell EMC Services offering that automates technical support for your Dell EMC server, storage, and networking devices. By installing and setting up a SupportAssist application in your IT environment, you can receive the following benefits:

- **Automated issue detection** — SupportAssist monitors your Dell EMC devices and automatically detects hardware issues, both proactively and predictively.
- **Automated case creation** — When an issue is detected, SupportAssist automatically opens a support case with Dell EMC Technical Support.
- **Automated diagnostic collection** — SupportAssist automatically collects system state information from your devices and uploads it securely to Dell EMC. This information is used by Dell EMC Technical Support to troubleshoot the issue.
- **Proactive contact** — A Dell EMC Technical Support agent contacts you about the support case and helps you resolve the issue.



The available benefits vary depending on the Dell EMC Service entitlement purchased for your device. For more information about SupportAssist, go to [www.dell.com/supportassist](http://www.dell.com/supportassist).

## Recycling or End-of-Life service information

Take back and recycling services are offered for this product in certain countries. If you want to dispose of system components, visit [www.dell.com/recyclingworldwide](http://www.dell.com/recyclingworldwide) and select the relevant country.

## Documentation resources

This section provides information about the documentation resources for your system.

To view the document that is listed in the documentation resources table:

- From the Dell EMC support site:
  1. Click the documentation link that is provided in the Location column in the table.
  2. Click the required product or product version.
-  **NOTE:** To locate the product name and model, see the front of your system.
- 3. On the Product Support page, click **Manuals & documents**.
- Using search engines:
  - Type the name and version of the document in the search box.

**Table 29. Documentation resources**

Task	Document	Location
Setting up your system	<p>For more information about installing and securing the system into a rack, see the Rail Installation Guide included with your rack solution.</p> <p>For information about setting up your system, see the <i>Getting Started Guide</i> document that is shipped with your system.</p>	<a href="https://www.dell.com/poweredgemanuals">https://www.dell.com/poweredgemanuals</a>
Configuring your system	<p>For information about the iDRAC features, configuring and logging in to iDRAC, and managing your system remotely, see the Integrated Dell Remote Access Controller User's Guide.</p> <p>For information about understanding Remote Access Controller Admin (RACADM) subcommands and supported RACADM interfaces, see the RACADM CLI Guide for iDRAC.</p> <p>For information about Redfish and its protocol, supported schema, and Redfish Eventing implemented in iDRAC, see the Redfish API Guide.</p> <p>For information about iDRAC property database group and object descriptions, see the Attribute Registry Guide.</p> <p>For information about Intel QuickAssist Technology, see the Integrated Dell Remote Access Controller User's Guide.</p>	<a href="https://www.dell.com/poweredgemanuals">https://www.dell.com/poweredgemanuals</a>
	<p>For information about earlier versions of the iDRAC documents.</p> <p>To identify the version of iDRAC available on your system, on the iDRAC web interface, click <b>? &gt; About</b>.</p>	<a href="https://www.dell.com/idracmanuals">https://www.dell.com/idracmanuals</a>
	For information about installing the operating system, see the operating system documentation.	<a href="https://www.dell.com/operatingsystemmanuals">https://www.dell.com/operatingsystemmanuals</a>

**Table 29. Documentation resources (continued)**

Task	Document	Location
	For information about updating drivers and firmware, see the Methods to download firmware and drivers section in this document.	<a href="http://www.dell.com/support/drivers">www.dell.com/support/drivers</a>
Managing your system	For information about system management software offered by Dell, see the Dell OpenManage Systems Management Overview Guide.	<a href="https://www.dell.com/poweredgemanuals">https://www.dell.com/poweredgemanuals</a>
	For information about setting up, using, and troubleshooting OpenManage, see the Dell OpenManage Server Administrator User's Guide.	<a href="http://www.dell.com/openmanagemanuals">www.dell.com/openmanagemanuals</a> > OpenManage Server Administrator
	For information about installing, using, and troubleshooting Dell OpenManage Enterprise, see the Dell OpenManage Enterprise User's Guide.	<a href="https://www.dell.com/openmanagemanuals">https://www.dell.com/openmanagemanuals</a>
	For information about installing and using Dell SupportAssist, see the Dell EMC SupportAssist Enterprise User's Guide.	<a href="https://www.dell.com/serviceabilitytools">https://www.dell.com/serviceabilitytools</a>
	For information about partner programs enterprise systems management, see the OpenManage Connections Enterprise Systems Management documents.	<a href="https://www.dell.com/openmanagemanuals">https://www.dell.com/openmanagemanuals</a>
Working with the Dell PowerEdge RAID controllers	For information about understanding the features of the Dell PowerEdge RAID controllers (PERC), Software RAID controllers, or BOSS card and deploying the cards, see the Storage controller documentation.	<a href="http://www.dell.com/storagecontrollermanuals">www.dell.com/storagecontrollermanuals</a>
Understanding event and error messages	For information about the event and error messages generated by the system firmware and agents that monitor system components, go to <a href="http://qrl.dell.com">qrl.dell.com</a> > <b>Look Up</b> > <b>Error Code</b> , type the error code, and then click <b>Look it up</b> .	<a href="http://www.dell.com/qrl">www.dell.com/qrl</a>
Troubleshooting your system	For information about identifying and troubleshooting the PowerEdge server issues, see the Server Troubleshooting Guide.	<a href="https://www.dell.com/poweredgemanuals">https://www.dell.com/poweredgemanuals</a>