

Mix Modular 2PC Sofa

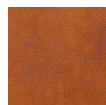

Parliament
Stone



Vegan
Appleskin
Cognac



Mowat
Ferro



Mowat
Raven



Mowat
Sand

The Mix Modular Collection lets you mix and match components and fabrics to build a custom sectional, sofa or seating group to perfectly suit your space. The design uses 7 basic components (Left Arm, Right Arm, Armless, Corner, Ottoman, Block Table & Prism Table) which can be combined to create an unlimited number of seating configurations. Choose matching fabrics or mix things up to make it your own. Constructed with kiln-dried 100% FSC®-Certified hardwood in support of responsible forest management. Mix Modular uses a clean, ultra soft, long-strand fiber fill material that offers the comfort and feel of traditional waterfowl down. This material is created through a process that benefits the environment by diverting 158 plastic bottles away from landfills, waterways and oceans for each Mix Modular Sofa we build.

Design Trade Professionals: We aim to keep our designs in stock and ready to ship quickly for projects on a tight timeline. Designs may be customized with COM and alternate finishes (minimum quantities may apply). Visit gusmodern.com for more information about our Trade & Contract programs.

Mix Modular 2PC Sofa

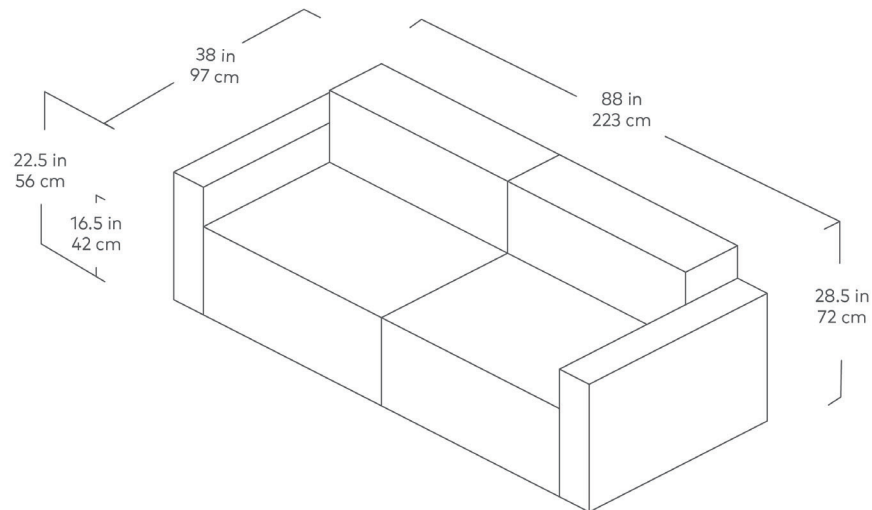

- 7 different components - Arm Left Facing, Arm Right Facing, Armless, Corner, Ottoman, Block Table & Prism Table.
- Bolster cushions contain an eco-friendly, synthetic-down fill made from 79 recycled plastic water bottles.
- Each component includes concealed connectors to securely join them to each other while in sectional, sofa or chaise formation.
- Frame is kiln-dried 100% FSC®-Certified hardwood (FSC® 092551).
- Wood block legs are FSC®-Certified Ash in a Black stain.
- Plastic bumpers on all legs to prevent floor damage.
- All joints have been stress tested.
- Manufactured to meet California TB117-2013 fire safety standards without the use of flame retardant additives in the upholstery foam.

