

### Parts List

01

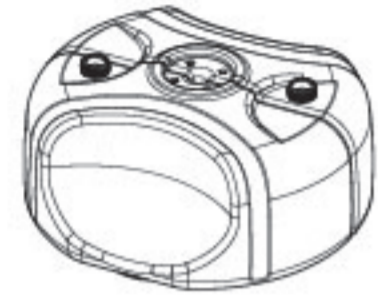

A. Base  
x 2



B. Base Cap  
x 2



C. Base Support Plate  
x 2



D. Base Plug  
x 1



E. Base Plug Cover  
x 1



F. Base Plate  
x 1

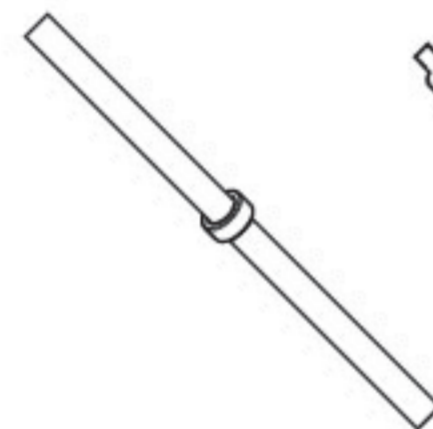

G. Lower Pole  
x 1

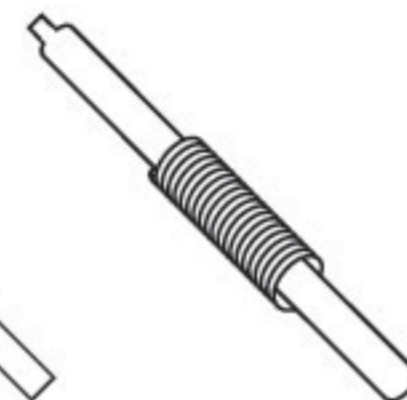

H. Middle Pole  
x 1



I. Punch Ball  
x 1



J. Bolt M8 x 50mm  
x 1



K. Bolt M8 x 12mm  
x 4



L. Bolt M8 x 16mm  
x 4



M. Bolt M6 x 30mm  
x 2



N. Nut M6  
x 2

### Assembly Instructions

02

#### Step 1

Turn the Base x 2 (A) over and connect them using 2 x Base Support Plate (C) and 4 x Bolts M8 x 12mm (K).

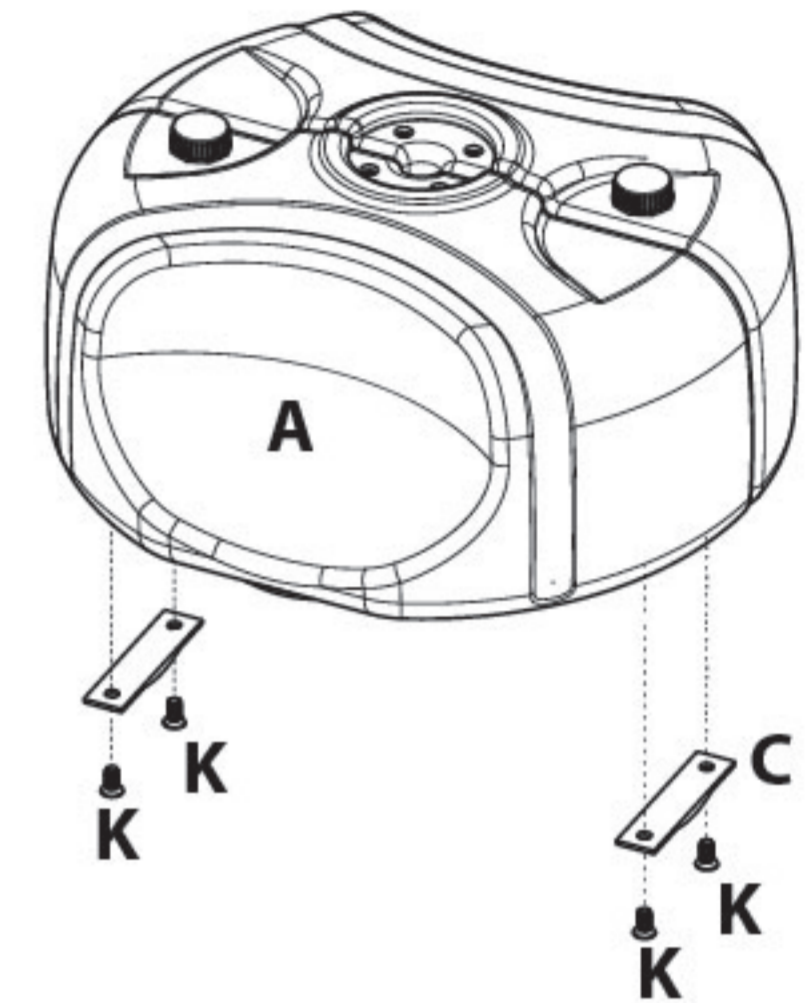

#### Step 2

Turn Base (A) over and then place Base Plug (D) into the hole of the Base (A), cover Base Plug (D) with Base Plug Cover (E) and secure them into place using Bolt M6 x 40mm (n).

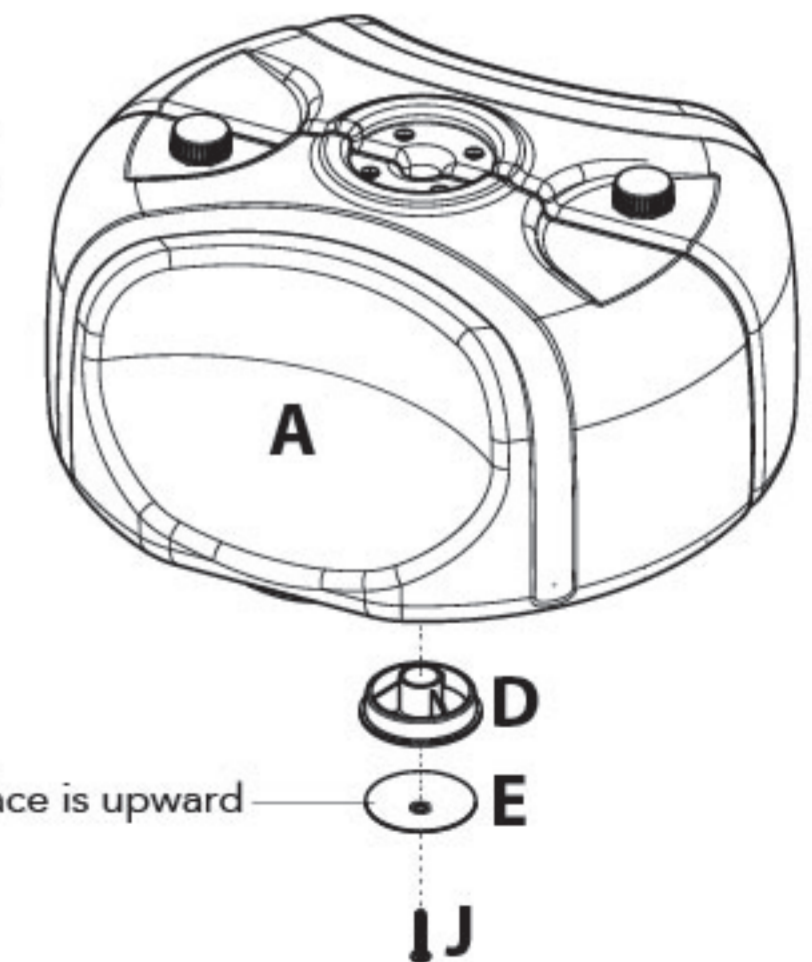



Assembly Instructions

03

Step 3

Attach Base Plate (F) to the Base (A) using 4 x Bolts M8 x 16mm (L). Slide Lower Pole (G) through the hole at the top of Base Plate (F) until the collar stop on the end of Lower Pole (G) sits on top of the Base Plate (F).

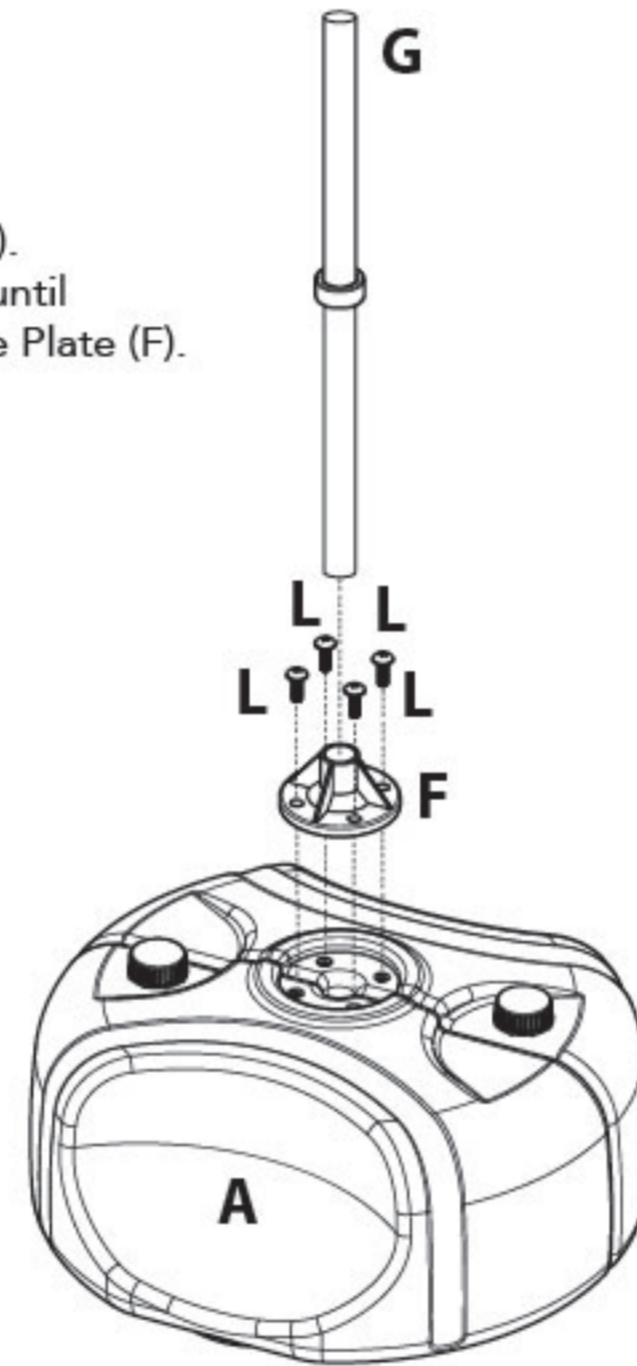

Step 4

Slide Lower Pole (G) into the Middle Pole (H) attach with Bolt M6 x 30mm (M) & Nut (N).

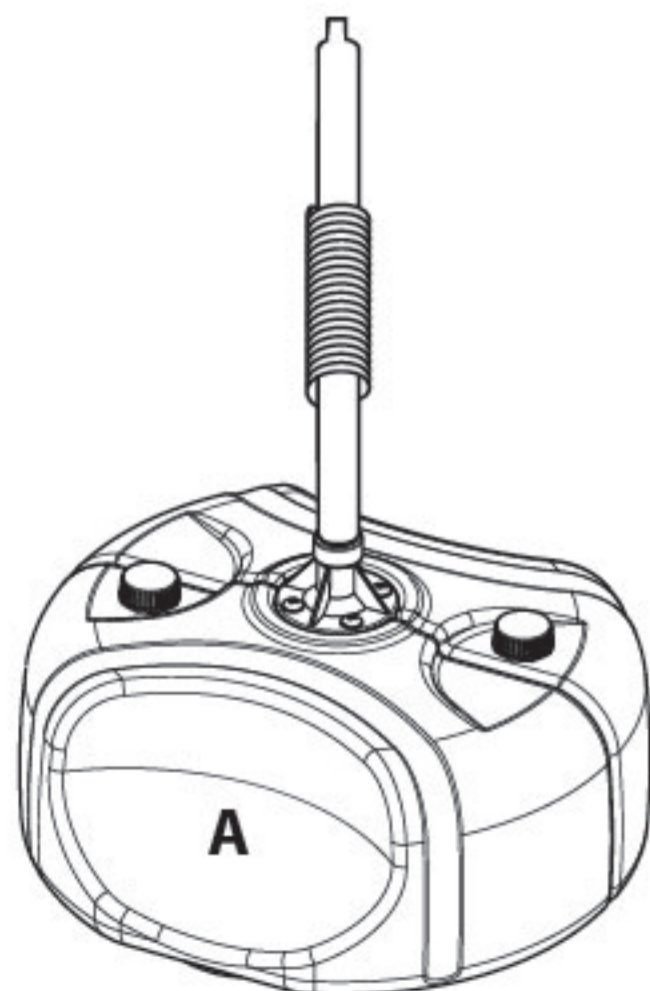

Assembly Instructions

04

Step 5

Slide Punch Ball (I) over Middle Pole (H). Secure the Punch Ball (I) to the Middle Pole (H) with Bolt M6 x 30mm (Q) and Nut M6 (R).

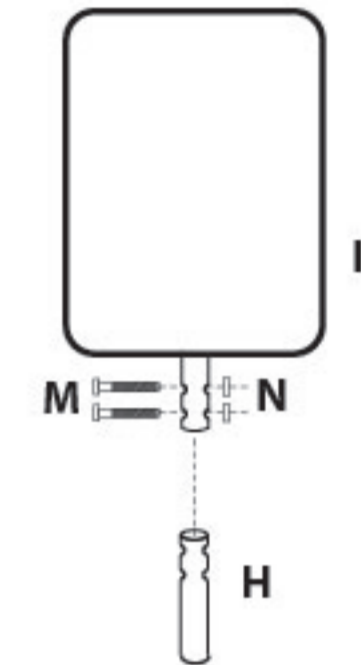

Step 6

Place 2 x Base (A) on the ground and remove 2 x Base Cap (B). Fill the Base (A) with either water or sand and then screw the Base Caps (B) back onto the Base (A).

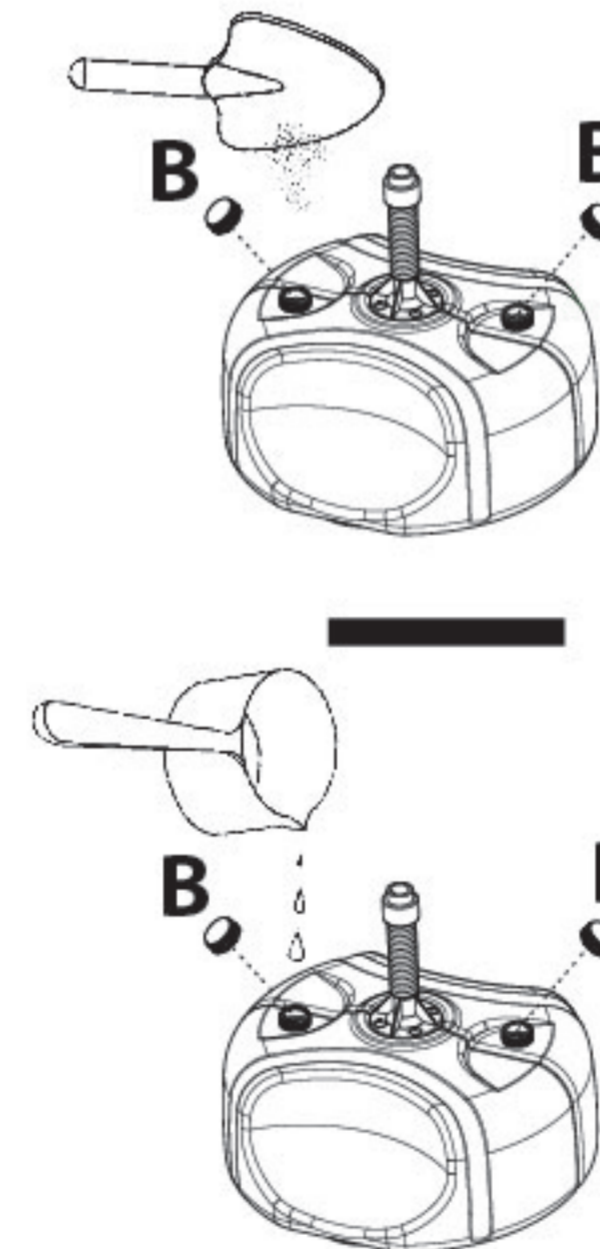

Step 7

Slide the part of step 5 into the part of step 6 and screw the Middle Pole (I) into the Spring Cover Cap (G), ensure all the parts are connected firmly.

Finish

Note:  
Height is Adjustable.  
There is Max Height  
Marked on Middle Pole (K).



WARNING: Prior to using any exercise product it is suggested that you receive a complete physical examination and obtain your physicians approval of your exercise conditioning program. This is not a Toy. GoZone assumes no liability or responsibility for accidents or injury to person or property that may result from the improper use of this product. Be sure to consult your physician prior to use.



## Liste des Pièces

01



A. Base  
x 2



B. Capuchon  
de la Base  
x 2



C. Plaque de  
Support de la Base  
x 2



D. Bouchon  
de la Base  
x 1



E. Couvercle du  
Bouchon de la Base  
x 1



F. Plaque  
de la Base  
x 1

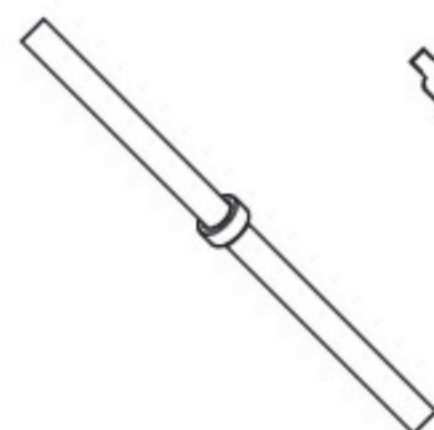

G. Poteau  
Inférieur  
x 1

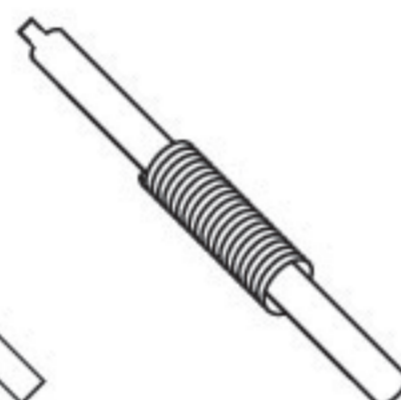

H. Poteau du Milieu  
x 1



I. Ballon de Frappe  
x 1



J. Boulon M8 x 50mm  
x 1

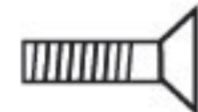

K. Boulon M8 x 12mm  
x 4



L. Boulon M8 x 16mm  
x 4



M. Boulon M6 x 30mm  
x 4



N. Écrou M6  
x 4

## Instructions d'Assemblage

02

### Étape 1

Retourner les 2 parties de la base (A) et les attacher ensemble à l'aide de la plaque de support de la base (C) et des 4 boulons M8 x 8 mm (O).

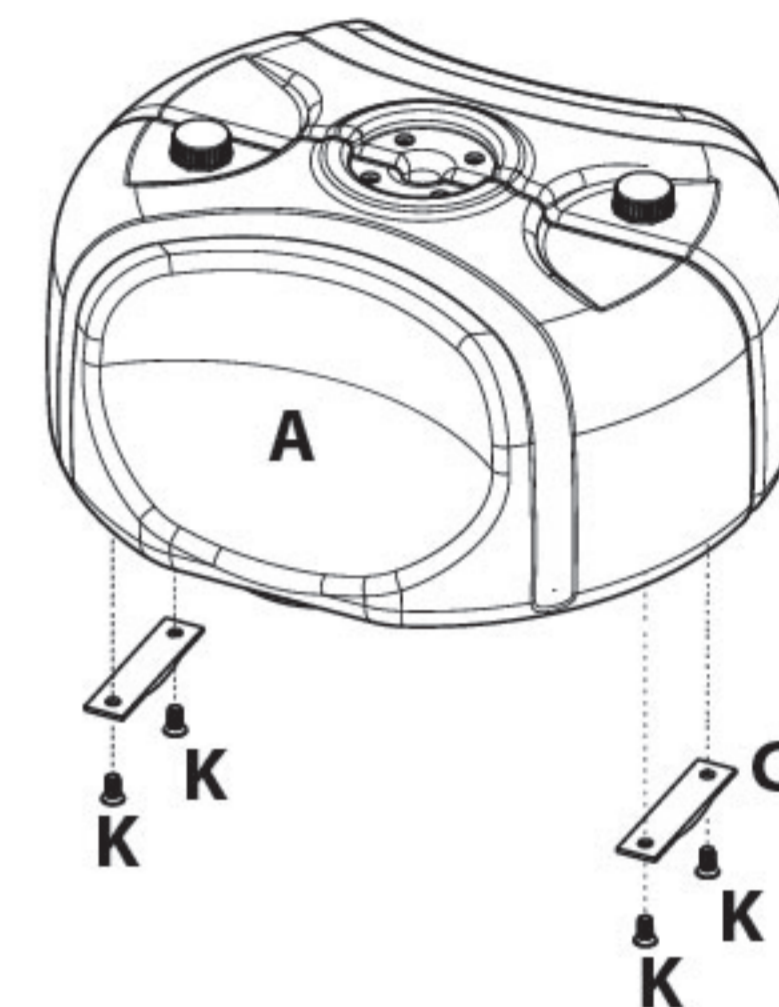

### Étape 2

Retourner la base (A) et installer le bouchon de la base (D) dans le trou de la base (A). Couvrir le bouchon de la base avec le couvercle du bouchon de la base (E) et les fixer en place avec le boulon M6 x 40 mm (N).

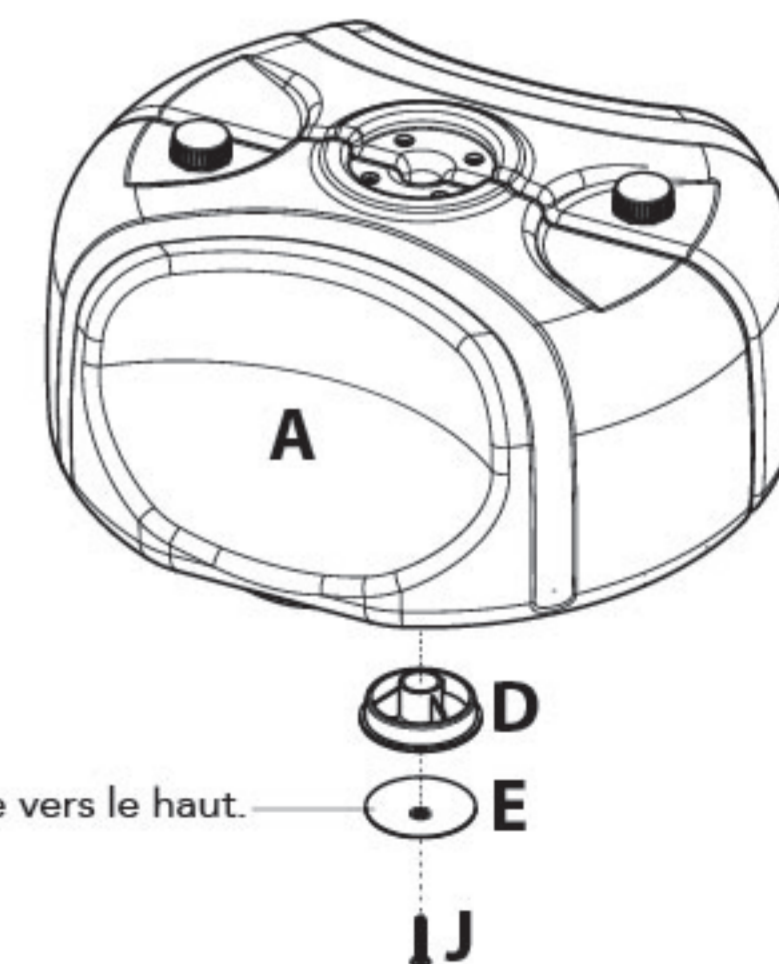

La surface concave est dirigée vers le haut.



Instructions d'Assemblage

03

Étape 3

Attacher la plaque de la base (F) à la base (A) à l'aide des 4 boulons M8 x 16 mm (L). Glissez le poteau inférieur (G) dans le trou en haut de la plaque de base (F) jusqu'à ce que la butée du col au bout du poteau inférieur (G) repose sur la plaque de base (F).

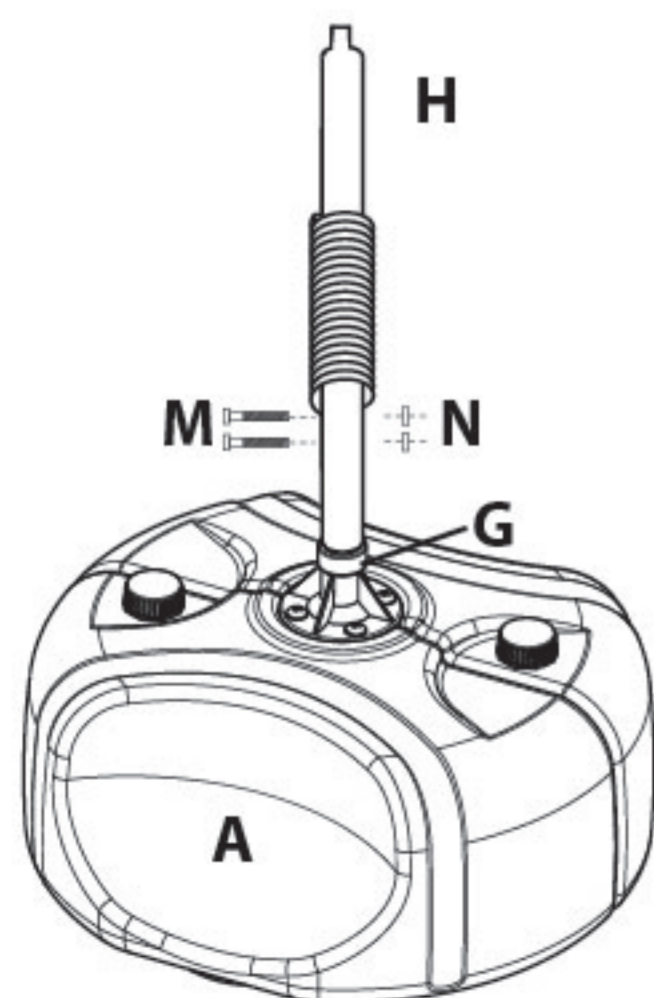
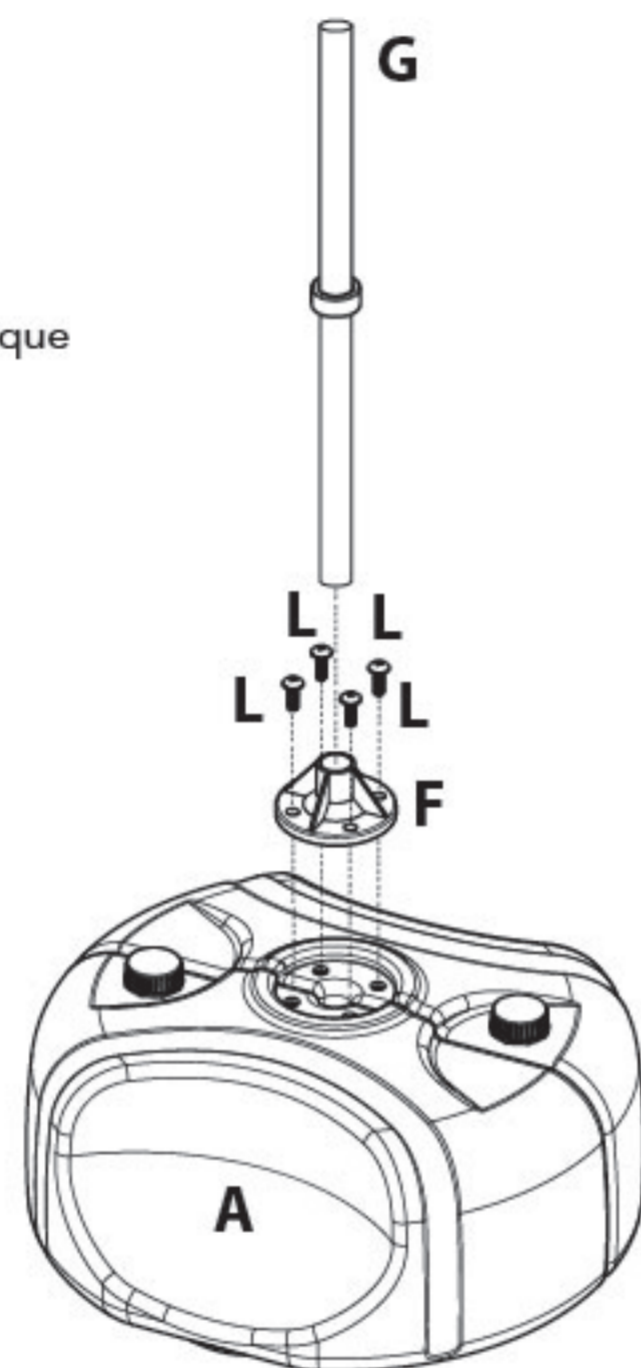

Étape 4

Faites glisser le poteau inférieur (G) dans le poteau central (H) fixer avec boulon M6 x 30 mm (M) et écrou (N).

Instructions d'Assemblage

04

Étape 5

Faire glisser la ballon de Frappe (I) sur le Poteau Centrale (H). Attacher le ballon de frappe (M) au Poteau Centrale (H) avec le boulon M6 x30mm (M) et l'écrou M6 (N).

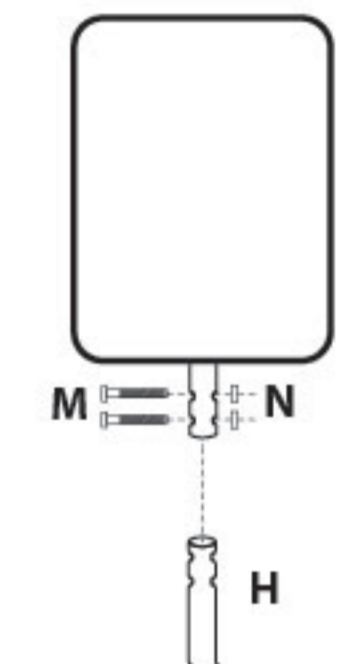

Étape 6

Placer la base (A) sur le sol et retirer les 2 capuchons de la base (B). Remplir la base (A) d'eau ou de sable, puis revisser les capuchons dans la base (A).

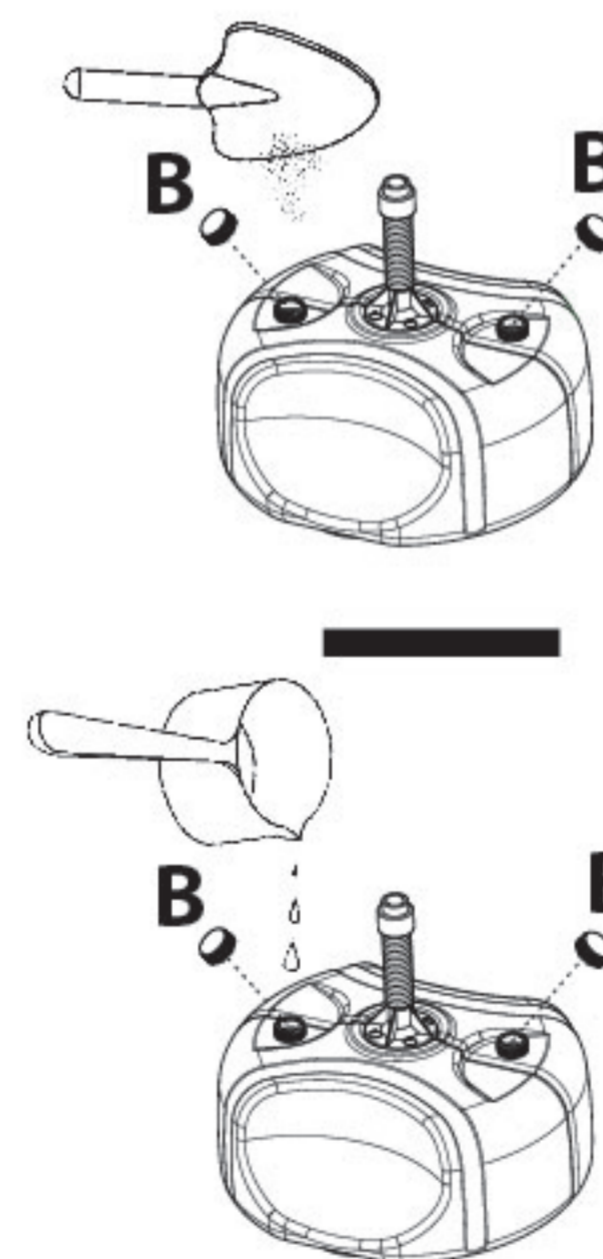

Étape 7

Faire glisser l'assemblage de l'étape 5 dans l'assemblage de l'étape 6 et visser le poteau du milieu (I) dans le capuchon à ressort (G). S'assurer que toutes les pièces sont bien connectées.

Produit assemblé

Remarque:  
la hauteur est réglable.  
La hauteur maximale est indiquée sur le poteau Centrale (H).



**AVERTISSEMENT :** avant d'utiliser un accessoire d'exercices, il est recommandé de passer un examen médical complet et d'obtenir l'autorisation d'un médecin pour le programme de conditionnement. Il ne s'agit pas d'un jouet. GoZone n'assume aucune responsabilité pour des accidents, des blessures ou des dommages à des biens qui pourraient résulter d'une mauvaise utilisation de ce produit. Consulter un médecin avant d'utiliser ce produit.