

# delta

## Wearable Safety Beacons

### Assembly instructions

#### Parts

- A** x1 — Beacon (Front & Rear)
- B** x1 — Mount
- C** x1 — Mount Band

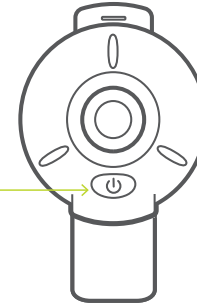
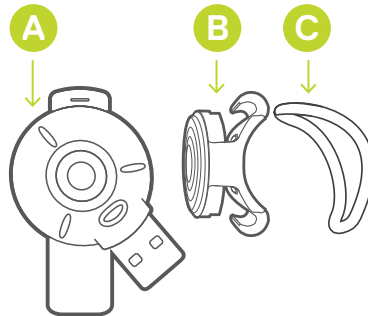

#### Operation modes:

ACTION	LIGHT MODE	EST. RUN TIME
Press once (1)	Pulsing	10 Hours
Press again (2)	Constant Beam	3.5 Hours
Press again (3)	Movement Detection*	20 Hours

\*3 quick flashes indicates movement mode activated. Light will stop flashing if no movement is detected for 7 seconds.

### USB Charging

Charge periodically in any USB port or when light appears dimmer.  
**Charge Time:** approx 50 mins  
 Slow pulse while charging.  
 Constant light when fully charged.



**IMPORTANT NOTE**  
 Failure to charge after extensive use may affect battery life.

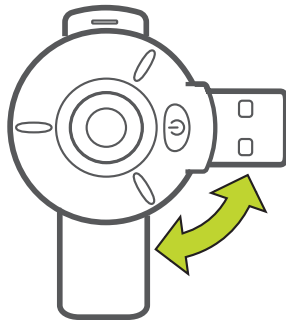

### Attach to Mount

- 1** Slide beacon into mount, be sure it is lined up securely.
- 2** Attach band, wrap around bar secure other side to bottom hook.

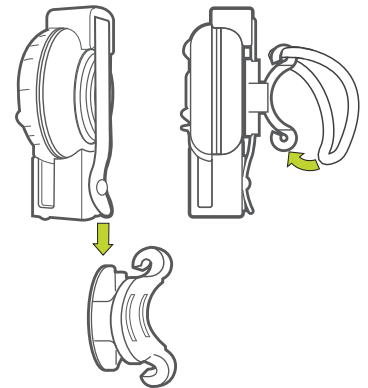

### Attachment Option

- 1** Zip Ties (not included) can be used for permanent attachment of mount and to secure to larger size bars.

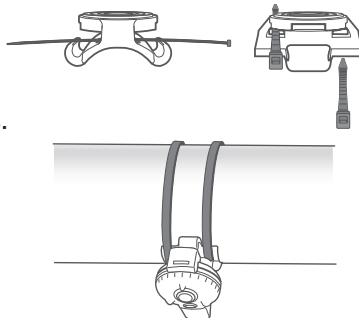

### WARNING

Do not look directly into this light.  
 May cause temporary blindness.

**CHOKING HAZARD!**  
 Not to be used by children under 5 years old.



**IMPORTANT NOTE**  
 Max width of Zip Ties is 5mm, (3/16")

### Easy Attachment Anywhere

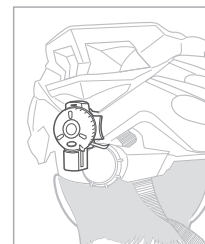
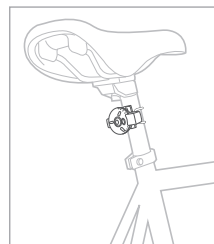
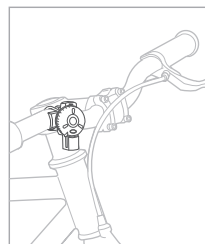
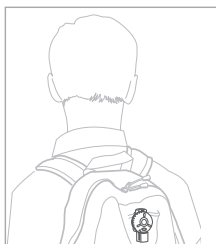

### Assembly video

Visit [designbydelta.com/downloads](http://designbydelta.com/downloads)

