

FHO24R11-SS

# 24" Undercabinet Rangehood

---



## Main Features

---

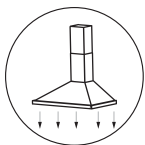

HIGH  
EXTRACTION RATE



ALUMINIUM  
FILTER

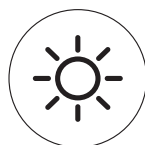

LED  
LIGHT



DUCTED AND  
DUCTLESS

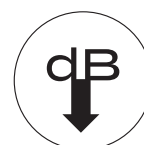

QUIET  
OPERATION

**FURRION**

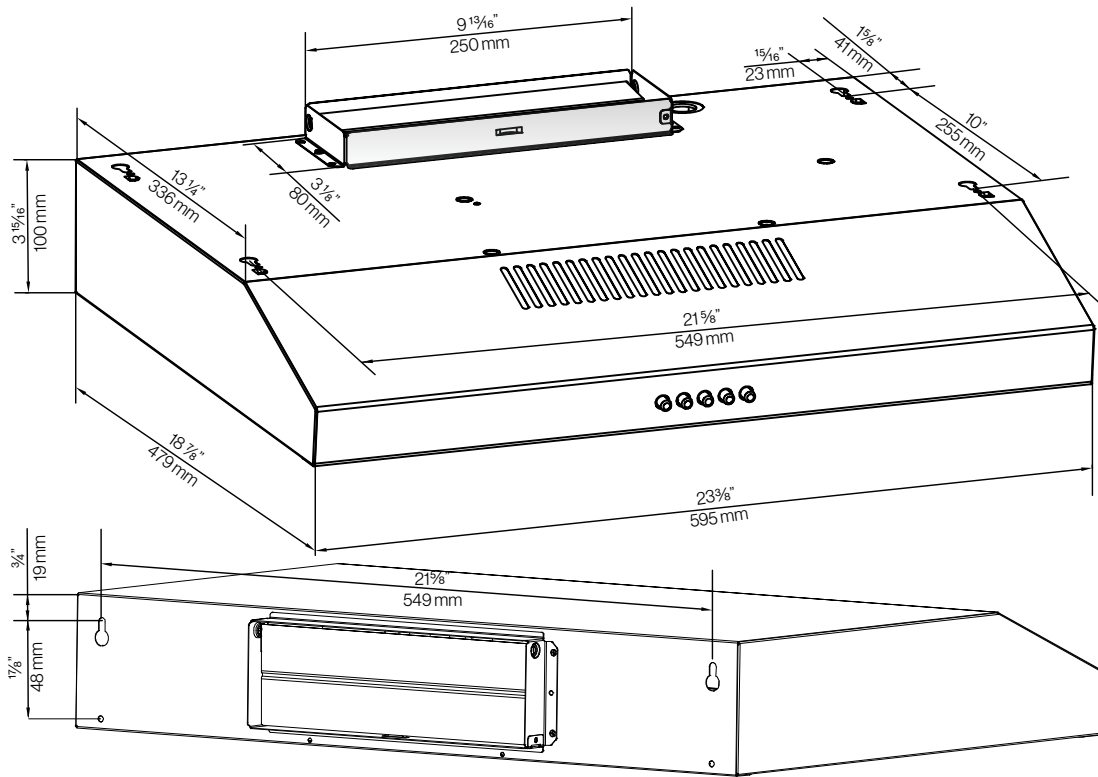

## Specifications

Rating Voltage	120V AC
Rating Power	63W (Including the LED)
	2 x 1.5W (LED)
Available Colors	Stainless Steel
Collar Length	1"
Rough Opening (Rear/Top)	3 1/8" x 9 13/16"
CFM Standard	100CFM
Internal Wire Temp Rating	105° C
Noise	63dB

## Special Features

Button for Fan Power ON/OFF	√
Button for LED Light ON/OFF	√
ETL Certificate	√
Ductless or Ducted *	√

## Dimensions and Weight

Product Dimensions (W x H x D)	23.43 x 3.94 x 18.86" (595 x 100 x 479mm)
Packaging Type	Master Carton Box
Quantity Per Box (pcs)	1
Packaging Dimensions (W x H x D)	24.8 x 5.71 x 20.87" (630 x 145 x 530mm)
Net Weight (kg/lbs)	4.6 / 10.1
Gross Weight (kg/lbs)	6.2 / 13.7

## Container Load Information

40'HQ Container Load (pcs)	1300
----------------------------	------

\* Product in recirculation mode requires a charcoal filter C-FHO24R11-009 (sold separately).

