



ASSEMBLING INSTRUCTION

WALL SHELF

Pre Assembly :

- Please read all instructions before beginning assembly
- Place all parts on a carpet or foam in shipping box. Find the sticker or letter (A,B,C,...) on each part and check with below part list to ensure we have all components.
- Save all packing materials until assembly is complete to avoid accidentally discarding smaller parts or hardware.
- This cart requires one people to do assembly.

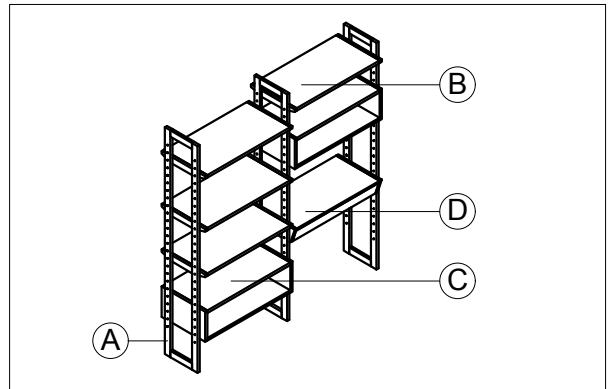

Parts Included :

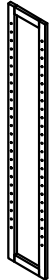
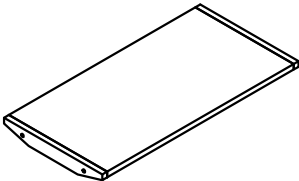
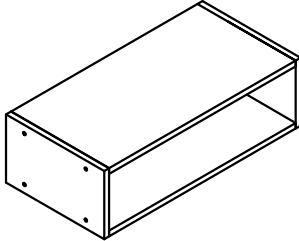
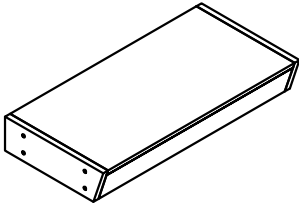
A - Leg - 3 pcs 	B - Shelves - 4 pcs 
C - Large Box - 2 pcs 	D - Small Box - 1 pc 

Hardware Enclosed :

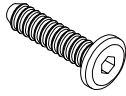
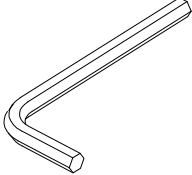
E - Bolt - 40 pcs	F - Allen Key - 1 pc
	

Assembly Instructions :

1. Attach Shelves (B) and Large Box (C) to the Leg (A).
Secured by Bolt (E). Tighten by using Allen Key (F)
2. Otherside, Attach Shelves (B), Large Box (C) and Small Box (D) to the Leg (A).
Secured by Bolt (E). Tighten by using Allen Key (F). Assembly is complete

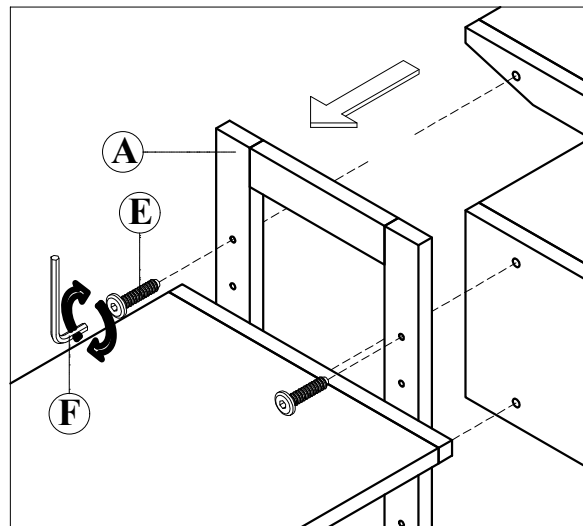
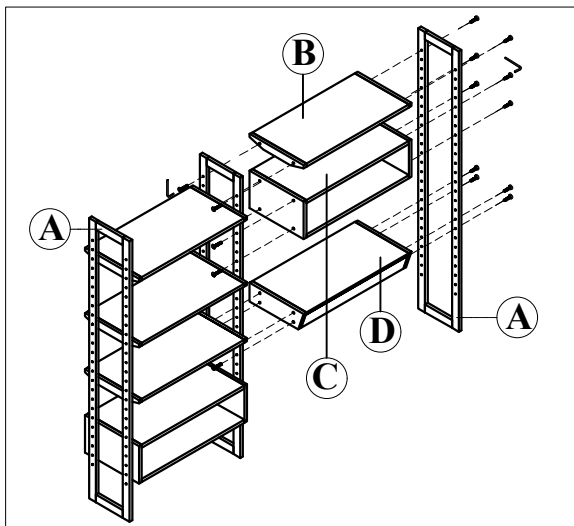
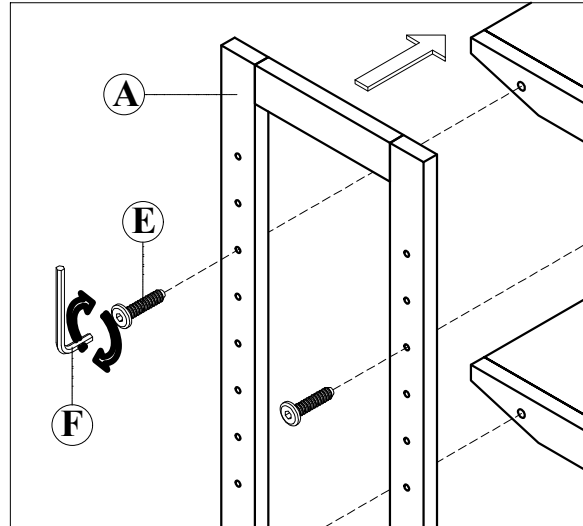
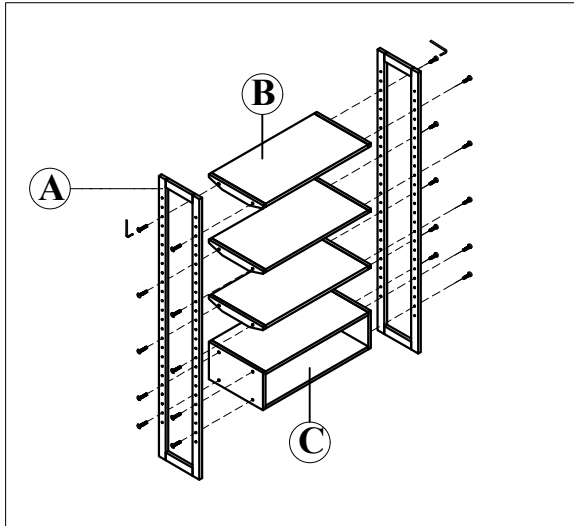

Care Instructions :

- Hardware may loosen over time. Periodically check to make sure all components are tight. Re-tighten if necessary.
- Dust with soft dry cloth.
- Avoid abrasive cleaners. If a cleaner is needed, use a mild-cleaner spray and blot with an absorbent cloth.
- For indoor use only.