



ASSEMBLING INSTRUCTION

DESK TABLE

Pre Assembly :

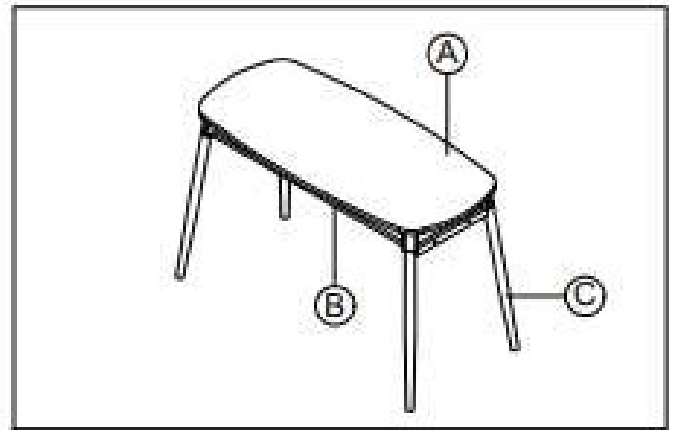

- Please read all instructions before beginning assembly
- Place all parts on a carpet or foam in shipping box. Find the round sticker with letter (A,B,C,...) on each part and check with below part list to ensure we have all components.
- Save all packing materials until assembly is complete to avoid accidentally discarding smaller parts or hardware.
- This cart requires one people to do assembly.

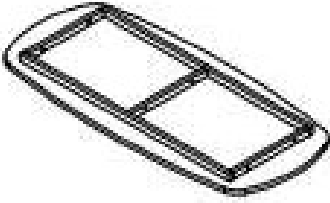
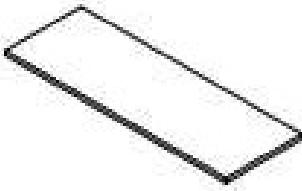
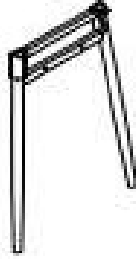

Parts Included :

A - Top Table - 1 pc	B - Shelve - 1 pc	C - Legs - 2 pcs
		

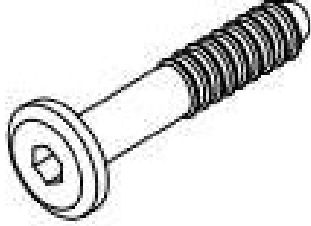
Hardware Enclosed:

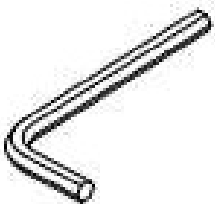
D - Longer JCBC Bolt - 14 pcs	E - Shorter JCBC Bolt - 4 pcs	F - Allen Key - 1 pc
		

Assembly Instructions :

1. Lay Top Table (A) onto clean smooth surface as carpet or cardboard.
Please note the indicating stickers or letter for homing guidance.
2. Attach Leg (C) to the Top Table (A) by aligning into wooden Frame holes, and secured by Longer JCBC Bolts (D). Tighten by using Allen Key (F).
3. Attach Shelf (B) to the Leg (C). Secured from outside by Longer JCBC Bolt (D) Tighten by using Allen Key (F).
4. Fix Metal Support. Secured by Shorter JCBC Bolt (E). Tighten by using Allen Key (F)
5. Turn up the desk table. Assembly is complete.

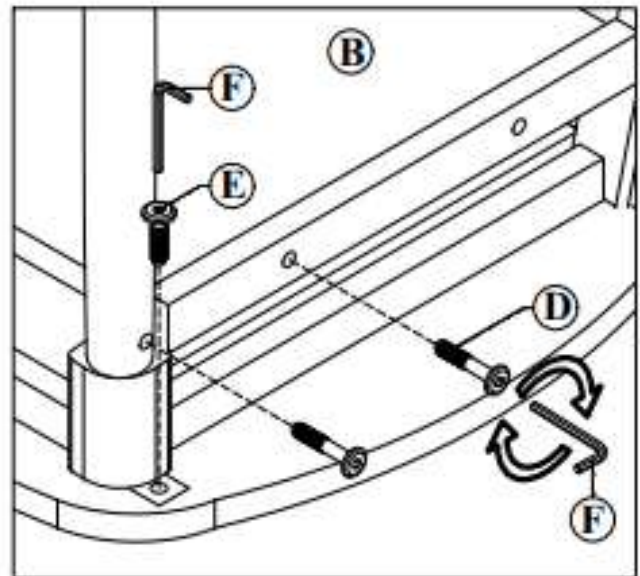
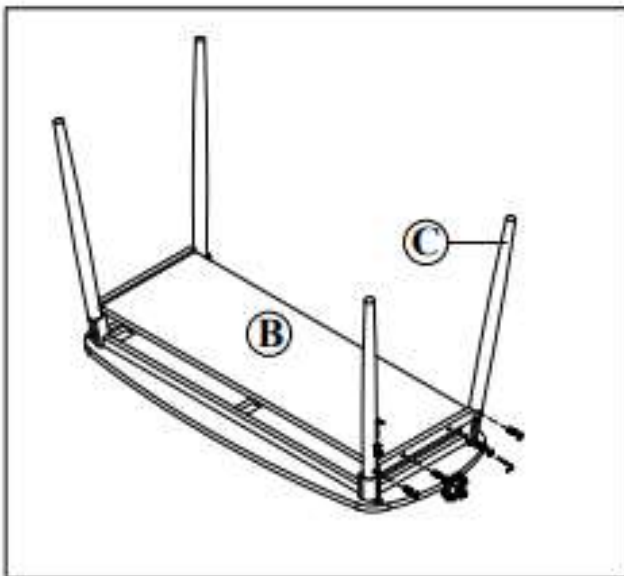
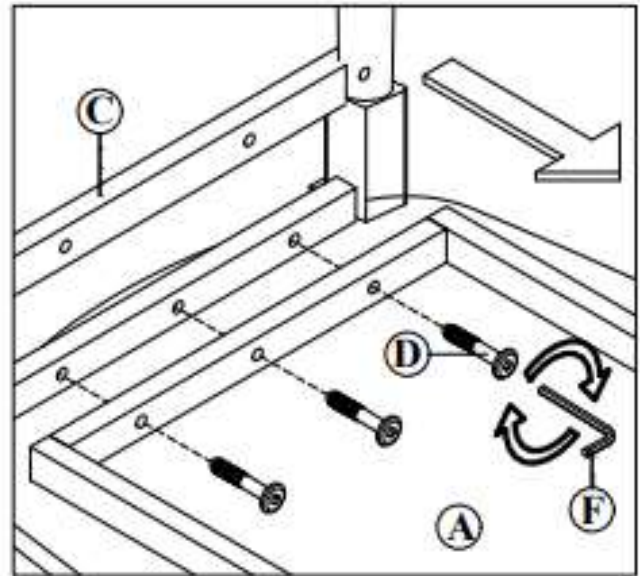
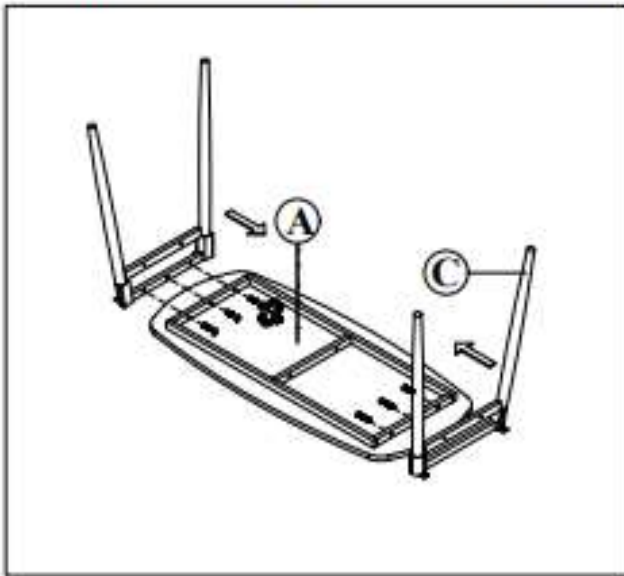

Care Instructions :

- Hardware may loosen over time. Periodically check to make sure all components are tight. Re-tighten if necessary.
- Dust with soft dry cloth.
- Avoid abrasive cleaners. If a cleaner is needed, use a mild-cleaner spray and blot with an absorbent cloth.
- For indoor use only.