



LION BRAND® WOOL-EASE® THICK & QUICK®
Knit Fairy Tale Poncho



Skill Level: Easy+

SIZE

12 months (2T, 4T)

Finished measurements 20 (24, 30)" wide, 17 (21, 27)" long

MATERIALS

- LION BRAND Wool-Ease Thick & Quick
- 2 (3, 5) balls #138 Cranberry (MC)
- 1 (1, 2) ball(s) #110 Navy (CC)
- or colors of your choice
- Six 1" (25 mm) buttons
- LION BRAND size 11 (8 mm) knitting needles OR SIZE TO OBTAIN GAUGE
- Size N-13 (9 mm) crochet hook
- Stitch holder
- 6" square of cardboard
- Large-eyed blunt needle

GAUGE

8 sts + 14 rows = 4" (10 cm) in Seed st. BE SURE TO CHECK YOUR GAUGE.

STITCH EXPLANATION

Seed Stitch

Row 1 *K 1, p 1; repeat from * across.

Row 2 Knit the p sts and purl the k sts.

Repeat Row 2 for pattern.

BACK

With MC, cast on 16 (20, 24) sts.

Row 1 Work in Seed st

Rows 2 and 5 (K 1, p 1) in first st – increase made; Seed st across.

Rows 3 and 4 (P 1, k 1) in first st, Seed st across.

Repeat last 4 rows until 40 (48, 60) sts on needle. Work even in Seed st until piece measures 16 (20, 26)" from beg, ending with a WS row.

Bind off all sts. Mark center 12 (14, 16) sts for Back neck.

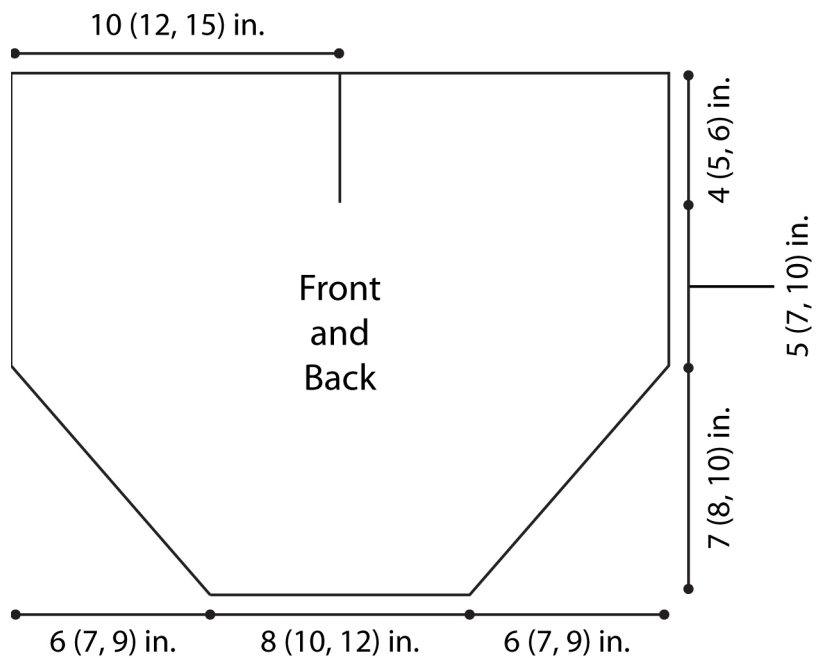

FRONT

Work as for Back until piece measures 12 (15, 20)" from beg, ending with a WS row. Divide for neck Work 20 (24, 30) sts, turn. Leaving other 20 (24, 30) sts on needle (on hold), continue working on these first 20 (24, 30) sts until piece measures same as Back, ending with a WS row. Bind off 14 (17, 22) sts, slip remaining 6 (7, 8) sts to holder. Cut yarn and rejoin at opposite edge to work 20 (24, 30) sts on hold (start with a WS row). Work in Seed st until same length as other side, ending with a RS row. Bind off 14 (17, 22) sts, Seed st across remaining 6 (7, 8) sts, turn.

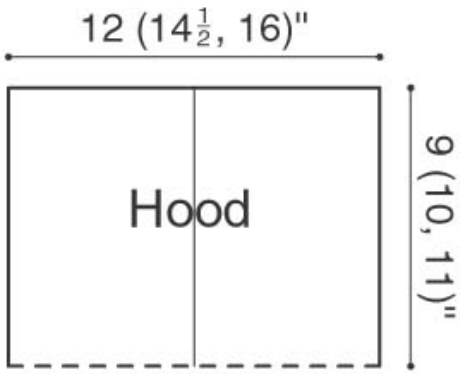
	<p>HOOD Keeping in Seed st, work 6 (7, 8) sts, pick up and knit 12 (15, 16) sts across Back neck, work remaining 6 (7, 8) Front sts from holder. Continue working in Seed st across these 24 (29, 32) sts until Hood measures 9 (10, 11)" long. Bind off all sts.</p> <p>FINISHING With MC, sew side/shoulder and Hood seams. With CC, work a round of single crochet around lower edge of Poncho. Work a second round in slip st, fasten off and weave in ends. Repeat for Hood edge.</p>
---	--

Make Tassel

Wrap CC around cardboard 20 times. Cut two 12" pieces of CC. Use crochet hook to draw one 12" piece under all strands at upper edge of cardboard. Pull tightly and knot securely near strands. Cut yarn loops at lower edge of cardboard and remove. Holding tied end at top, tie second piece around all 40 strands 1 1/2" from tied end, and knot securely. Weave ends of tie into center and trim Tassel ends evenly. Attach Tassel to point of Hood.

Button Fastener

With CC and crochet hook, make a 16" chain. Joining to form a loop, work 1 round in slip stitch. Fasten off. Fold loop and tie ends in an overhand knot. Position fastener across neck opening and sew a button on each side of opening to match fastener.

Sew remaining pairs of buttons 2" in from edge and 5" down from seam on each side.

<p align="center">ABBREVIATIONS</p>	
beg = begin(ning)	p = purl
CC = contrasting color	RS = right side
k = knit	st(s) = stitch(es)
MC = main color	WS = wrong side

Wool-Ease Thick & Quick (Article #640) comes in 6 oz/108 yd balls

Every effort has been made to have the knitting and crochet instructions accurate and complete. We cannot be responsible for variance of individual knitters and crocheters, human errors, or typographical mistakes.
To order call: (800) 258-YARN (9276)