



Free Knitting Pattern
Lion Brand® Lion® Cashmere Blend - Tiffany™
Knit Sweet Stripes Sweater Set
Pattern Number: 50681



Who could resist these sporty stripes? Especially when they're stitched up in super-soft yarns?

Free Knitting Pattern from Lion Brand Yarn

Lion Brand® Lion® Cashmere Blend - Tiffany™

Knit Sweet Stripes Sweater Set

Pattern Number: 50681

SKILL LEVEL: Beginner + (Level 2)

SIZE: 3-6 mos, 9 mos, 12 mos

SWEATER

3 (6-9, 12) months

Finished Chest 23 (24, 25) inches [58.5 (61, 63.5) cm]

Length 10 (11, 12) inches [25.5 (28, 30.5) cm]

BOOTIES

6 months

Length

3½ inches [9 cm]

Note: Pattern is written for smallest size with changes for larger sizes in parentheses. When only one number is given, it applies to all sizes. To follow pattern more easily, circle all numbers pertaining to your size before beginning.

CORRECTIONS: None as of Jun 27, 2016. To check for later updates, click [here](#).

MATERIALS

- 270-098 Lion Brand Lion Cashmere Blend Yarn: Cream (DISCONTINUED)
2 (2,3) Balls (A)

**Lion Cashmere Blend (Article #270). 72% Merino Wool, 15% Nylon, 13% Cashmere; package size: 1.50oz/40.00 gr. (84yds/71m) pull skeins*

- 270-105 Lion Brand Lion Cashmere Blend Yarn: Light Blue (DISCONTINUED)
2 (3,3) Balls (B)

- 260-098 Lion Brand Tiffany Yarn: Cream
1 Ball

**Tiffany™ (Article #260). 100% Nylon; package size: 1.75oz/50.00 gr. (137yds/125m) pull skeins*

- Lion Brand Knitting Needles - Size 7 [4.5 mm]
- Lion Brand Knitting Needles- Size 8 [5 mm]
- Lion Brand Knitting Needles- Size 9 [5.5 mm]
- Lion Brand Split Ring Stitch Markers
- Lion Brand Large-Eye Blunt Needles (Set of 6)



GAUGE:

Sweater: 20 sts + 27 rows = 4" [10 cm] in St st (k on RS, p on WS) on Size 8 [5mm] needles.

Booties: 23 sts = 4" [10 cm] in Garter st (knit every row) with largest needles and 2 strands of C held tog.

When you match the gauge in a pattern, your project will be the size specified in the pattern and the materials specified in the pattern will be sufficient. The needle or hook size called for in the pattern is based on what the designer used, but it is not unusual for gauge to vary from person to person. If it takes you fewer stitches and rows to make your swatch, try using a smaller size hook or needles; if more stitches and rows, try a larger size hook or needles.

[Making a Gauge Swatch](#)

STITCH EXPLANATION:

M1 (make 1 st) An increase worked by lifting the horizontal thread lying between the needles and placing it onto the left needle. Work this new stitch through the back loop.

NOTES:

Bootie is worked with 2 strands of C held together. Cuff is worked with 1 strand of B.

COLOR PATTERN

*6 rows A, 6 rows B; repeat from *.

BACK

With smaller needles and B, cast on 57 (60, 63) sts. Work in K1, P1 Rib for 1½ inches [4 cm], end with a WS row. Change to Size 8 [5mm] needles and A. Work Color Pattern in St st until piece measures 5½ (6, 6½)" [14 (15, 16.5) cm] from beg. Place markers for armholes. Continue in pattern until piece measures 9½ (10½, 11½)" [24 (26.5, 29) cm] from beg, end with a WS row.

Shape Neck

Continuing in pattern, k 17 (17, 20) sts, join a 2nd ball of yarn and bind off center 23 (26, 23) sts, knit to end of row. Working both sides at the same time, dec 2 sts at each neck edge once – 15 (15, 18) sts for each side. Work even until piece measures 10 (11, 12) inches [25.5 (28, 30.5) cm] from beg. Bind off.

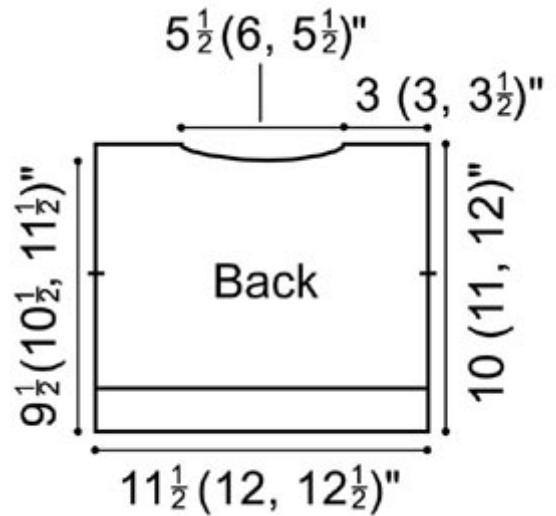

FRONT

Work as for Back until piece measures 7 (8, 9) inches [18 (20.5, 23) cm] from beg, end with a WS row.

Shape Neck

Continuing in pattern, k 24 (25, 27) sts, join a 2nd ball of yarn and bind off center 9 (10, 9) sts, knit to end of row. Working both sides at the same time, dec 2 sts at each neck edge 4 (5, 4) times, then 1 st 1 (0, 1) time(s) – 15 (15, 18) sts for each side. Work even until piece measures same as Back. Bind off

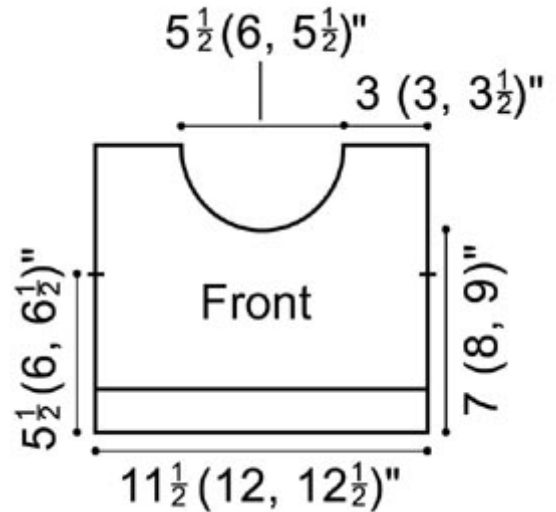

SLEEVES

With smaller needles and B, cast on 29 (31, 33) sts. Work in K1, P1

Rib for 1½ inches [4 cm], end with a WS row. Change to Size 8 [5mm] needles and knit 1 row, inc 4 (5, 4) sts evenly across row – 33 (36, 37) sts. Purl 1 row. Change to A. Continuing in Color Pattern, inc 1 st each end every 4 (5, 4) rows 7 (7, 9) times – 47 (50, 55) sts. Work even until piece measures 6¼ (7, 8) inches [16 (18, 20.5) cm] from beg. Bind off.

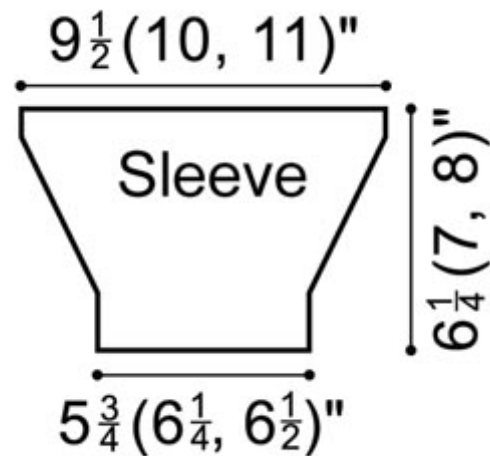

FINISHING

Sew one shoulder seam.

With RS facing, smaller needles, and B, pick up and knit 63 (65, 63) sts around neck edge. Work in K1, P1 Rib for ¾ inches [2 cm]. Bind off in pattern. Sew remaining shoulder seam. Sew Sleeves to body between markers. Sew side and Sleeve seams. Weave in ends.

BOOTIES

BOOTIE – Make 2

With largest needles and 2 strands of C held tog, cast on 31 sts.

Row 1 (WS) K 15, place marker, k 1, place marker, knit to end.

Row 2 (RS) K 1, M1, knit to marker, M1, slip marker, k 1, slip marker, M1, knit to last st, M1, k 1 – 35 sts.

Repeat last row 2 more times – 43 sts.

Work 9 rows in Garter st, removing markers on first row.

Next Row (RS) K 18, k2tog, place marker, k 3, place marker, k2tog, k 18 – 41 sts.

Next Row (WS) Knit to 2 sts before marker, k2tog, k 3, k2tog, knit to end – 39 sts.

Repeat last row 6 more times – 27 sts.

Change to 1 strand of B. Work in K1, P1 Rib for 1½" [3.8 cm]. Bind off loosely in Rib.

ABBREVIATIONS / REFERENCES

Click for explanation and illustration

<u>beg</u> = begin(s)(ning)	<u>dec</u> = decreas(e)(s)(ing)
<u>inc</u> = increas(e)(s)(ing)	<u>k</u> = knit
<u>k2tog</u> = knit 2 together	<u>M1</u> = make 1
<u>p</u> = purl	<u>RS</u> = right side
<u>St st</u> = Stockinette stitch	<u>st(s)</u> = stitch(es)
<u>tog</u> = together	<u>WS</u> = wrong side

Learn to knit instructions: <http://www.lionbrand.com/learn/how-to-knit>

Every effort has been made to have the knitting and crochet instructions accurate and complete. We cannot be responsible for variance of individual knitters and crocheters, human errors, or typographical mistakes.

We want your project to be a success! If you need help with this or any other Lion Brand pattern, e-mail support is available 7 days per week. Just click [here](#) to explain your problem and someone will help you!

For thousands of free patterns, visit our website www.LionBrand.com

To order visit our website www.lionbrand.com or call: (800) 258-YARN (9276) any time!

**When in New York City, visit the Lion Brand Yarn Studio where we have the largest selection of our yarns
anywhere and over 100 classes and events monthly.
34 West 15th Street, NY, NY 10011**

Copyright ©1998-2016 Lion Brand Yarn Company, all rights reserved. No pattern or other material may be reproduced -- mechanically, electronically, or by any other means, including photocopying -- without written permission of Lion Brand Yarn Company.