

LION BRAND[®] L40199

LEVEL 2-EASY KNIT VEST

LION BRAND[®] LION'S PRIDE[®] WOOLSPUN[®]

MATERIALS

- LION BRAND[®] LION'S PRIDE[®] WOOLSPUN[®] (Art. #671)
#141 Plum 6 (7, 8, 9) balls
or color of your choice
- LION BRAND[®] stitch holders
- LION BRAND[®] stitch markers
- LION BRAND[®] large-eyed blunt needle

ADDITIONAL MATERIALS

- Circular knitting needle size 10 (6 mm), 16 in. (40.5 cm) long
- Circular knitting needle size 10.5 (6.5 mm), 36 in. (91.5 cm) long



SIZE

S (M/L, 1X, 2X/3X)

Finished Bust About 44 (50, 56 1/2, 62 1/2) in.
(112 (127, 143.5, 159) cm)

Finished Length About 30 (30 1/2, 31, 31 1/2) in.
(76 (77.5, 78.5, 80) cm)

Note: Pattern is written for smallest size with changes for larger sizes in parentheses. When only one number is given, it applies to all sizes. To follow pattern more easily, circle all numbers pertaining to your size before beginning.

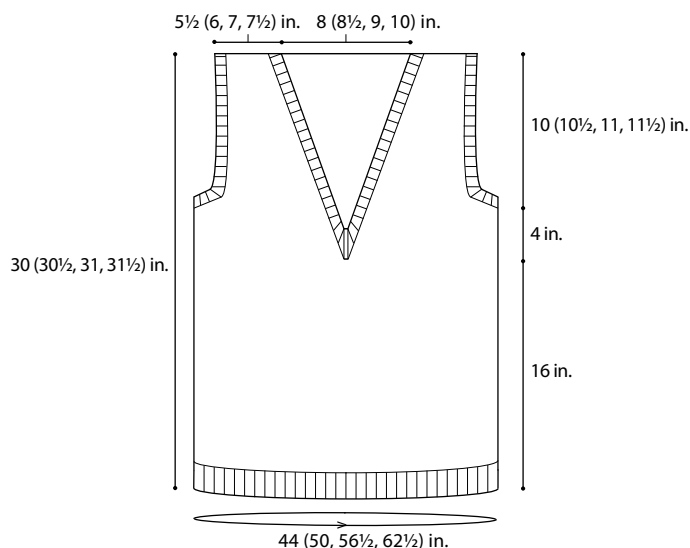

GAUGE

13 sts + 18 rnds = about 4 in. (10 cm) in St st worked in rnds (k every rnd).

BE SURE TO CHECK YOUR GAUGE.

STITCH EXPLANATION

ssk (slip, slip, knit) Slip next 2 sts as if to knit, one at a time, to right needle; insert left needle into fronts of these 2 sts and knit them together – 1 st decreased.

PATTERN STITCHES

K1, p1 Rib worked in rnds (worked over an even number of sts)

Rnd 1: *K1, p1; rep from * to end of rnd.
Rep Rnd 1 for K1, p1 Rib worked in rnds.

NOTES

1. Vest is worked in one piece in the rnd beg at lower edge, then divided to shape neck and armholes.
2. Vest is worked in St st – knit every rnd when working in rounds; k on RS, p on WS when working in rows.
3. When you see ‘work even’ in the instructions, this means to continue on in the pattern st you have established without changing the st count by increasing, decreasing, or binding off.
4. The neck and armhole bands are worked by picking up sts from the Vest.

STEP 1

With longer needle, cast on 144 (164, 184, 204) sts. Place marker for beg of rnd. Join by working the first st on left hand needle with the working yarn from the right hand needle and being careful not to twist sts.

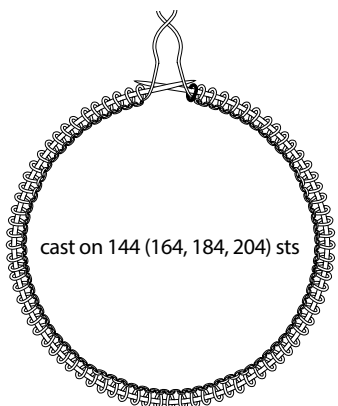

STEP 2

Work in K1, p1 Rib worked in rnds until piece measures about 2 ½ in. (6.5 cm) from beg.

Decrease Rnd: Knit to the last 2 sts, k2tog – you will have 143 (163, 183, 203) sts at the end of this rnd. Work in St st worked in rnds (k every rnd) until piece measures about 16 in. (40.5 cm) from beg.

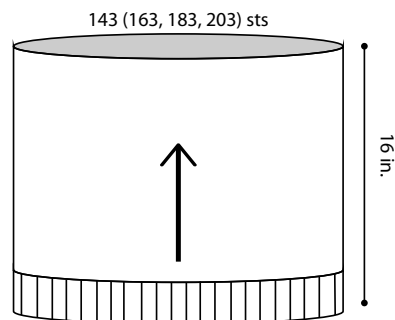

STEP 3

Shape V-Neck

Next Rnd (RS): Remove beg of rnd marker, bind off 1 st for V-neck, knit until there are 35 (40, 45, 50) sts on right needle for right front, place marker (pm) for side, k72 (82, 92, 102) for back, pm for side, knit rem 35 (40, 45, 50) sts for left front – 142 (162, 182, 202) sts.

Notes:

1. As you continue, slip markers as you come to them.
2. You will now be working back and forth in rows on the circular needle – just as if working on straight needles.

Turn to work across WS, beg at left front V-neck edge.

Next Row (WS): Purl.

Neck Decrease (RS): K2tog, k to last 2 sts, ssk – 140 (160, 180, 200) sts.

Next Row: Purl.

Next Row: Knit.

Next Row: Purl.

Rep last 4 rows 3 more times – 134 (154, 174, 194) sts.

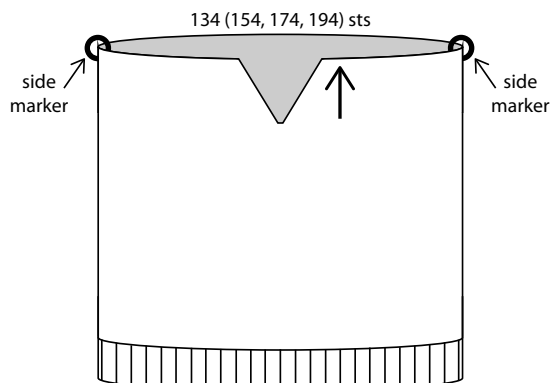

STEP 4

Divide for Fronts and Back

Next Row (RS): K2tog, k to first marker, remove marker, place the next 72 (82, 92, 102) sts onto a holder for back, remove the next marker, place rem 31 (36, 41, 46) sts on another holder for left front – you will have 30 (35, 40, 45) right front sts on the needle.

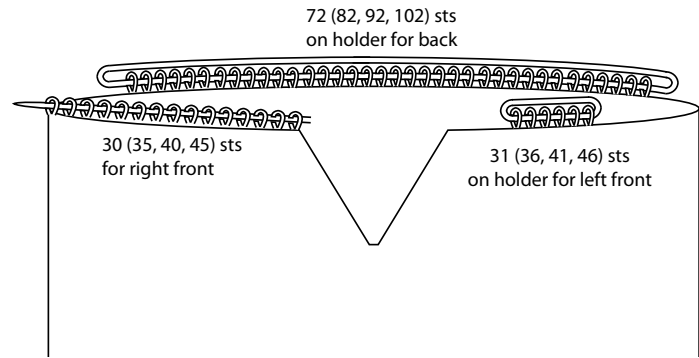

STEP 5

Right Front

Continuing on sts for right front only, shape neck and armhole as follows:

Next Row (WS): Bind off 2 (4, 6, 8) sts, p to end of row – 28 (31, 34, 37) sts.

Next Row: Knit.

Next Row: P2tog, p to end of row – 27 (30, 33, 36) sts.

Next Row: K2tog, k to end of row – 26 (29, 32, 35) sts.

Next Row: P2tog, p to end of row – 25 (28, 31, 34) sts.

Next Row: Knit.

Next Row: P2tog, p to end of row – 24 (27, 30, 33) sts.

Next Row: K2tog, k to end of row – 23 (26, 29, 32) sts.

Next Row: Purl.

Next Row: Knit.

Next Row: Purl.

Rep last 4 rows 5 (6, 7, 8) more times – 18 (20, 22, 24) sts.

Work even in St st worked in rows (k on RS, p on WS) until armhole measures about 10 (10 ½, 11, 11 ½) in. (25.5 (26.5, 28, 29) cm).

Bind off.

STEP 6

Left Front

Slip 31 (36, 41, 46) left front sts from holder onto longer needle, ready to work a RS row. Join yarn at armhole edge.

Next Row (RS): Bind off 2 (4, 6, 8) sts, k to last 2 sts, ssk – 28 (31, 34, 37) sts.

Next Row: Purl.

Next Row: K2tog, k to end of row – 27 (30, 33, 36) sts.

Next Row: Purl.

Next Row: K2tog, k to last 2 sts, ssk – 25 (28, 31, 34) sts.

Next Row: Purl.

Next Row: K2tog, k to end of row – 24 (27, 30, 33) sts.

Next Row: Purl.

Next Row: K to last 2 sts, ssk – 23 (26, 29, 32) sts.

Next Row: Purl.

Next Row: Knit.

Rep last 4 rows 5 (6, 7, 8) more times – 18 (20, 22, 24) sts.

Work even in St st worked in rows until armhole measures about 10 (10 ½, 11, 11 ½) in. (25.5 (26.5, 28, 29) cm).

Bind off.

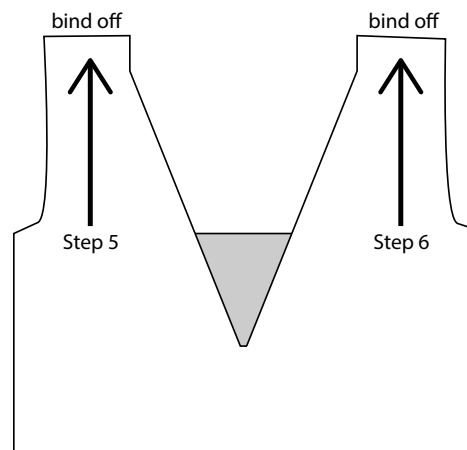

STEP 7

Back

Slip 72 (82, 92, 102) back sts from holder onto longer needle, ready to work a RS row. Join yarn at right armhole edge.

Next Row (RS): Bind off 2 (4, 6, 8) sts, k to end of row – 70 (78, 86, 94) sts.

Next Row: Bind off 2 (4, 6, 8) sts, p to end of row – 68 (74, 80, 86) sts.

Next Row: K2tog, k to last 2 sts, ssk – 66 (72, 78, 84) sts.

Next Row: Purl.

Next Row: K2tog, k to last 2 sts, ssk – 64 (70, 76, 82) sts.

Rep last 2 rows once more – 62 (68, 74, 80) sts.

Work even until armholes measure same as front.

Bind off.

STEP 8

Sew shoulders.

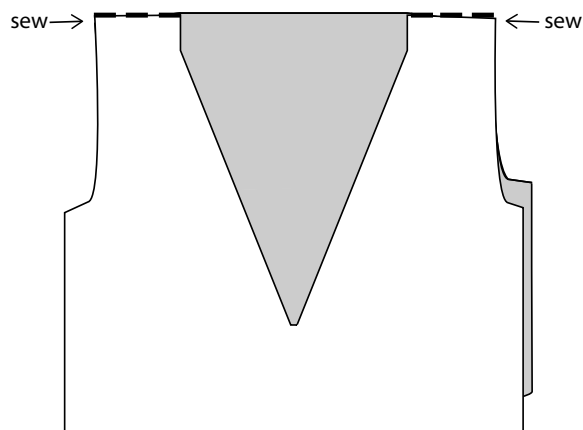

FINISHING

Neckband

From RS with longer needle and A, beg at left shoulder seam, pick up and k46 (48, 50, 52) sts evenly spaced down left edge of V-neck, pm, pick up and k1 st at center of V-neck, pm, pick up and k46 (48, 50, 52) sts evenly spaced up right edge of V-neck, pick up and k25 (27, 29, 31) sts evenly spaced across back neck – 118 (124, 130, 136) sts. Place marker for beg of rnd. Join by working the first st on left hand needle with the working yarn from the right hand needle.

Rnd 1: *K1, p1; rep from * to 2 sts before marker, ssk, sm, k1, sm, k2tog, p1, **k1, p1; rep from ** to end of rnd.

Rnds 2-6: K the knit sts and p the purl sts to 2 sts before marker, ssk, sm, k1, sm, k2tog, k the knit sts and p the purl sts to end of rnd.

Bind off.

Armhole bands

From RS with shorter needle and A, beg at underarm, pick up and k58 (60, 64, 66) sts evenly spaced around armhole. Place marker for beg of rnd. Join by working the first st on left hand needle with the working yarn from the right hand needle.

Work in K1, p1 Rib worked in rnds for 6 rnds.

Bind off. Rep band around opposite armhole.

Weave in ends.

ABBREVIATIONS

beg = begin(ning)(s)

k = knit

k2tog = knit 2 stitches together

p = purl

p2tog = purl 2 stitches together

rem = remain(ing)(s)

rep = repeat

RS = right side

rnd(s) = round(s)

st(s) = stitch(es)

St st = stockinette stitch

WS = wrong side