

LION BRAND<sup>®</sup>  
L40192

# LEVEL 3-EASY+ KNIT HAT

LION BRAND<sup>®</sup> LION'S PRIDE<sup>®</sup> WOOLSPUN<sup>®</sup>



## MATERIALS

- LION BRAND<sup>®</sup> LION'S PRIDE<sup>®</sup> WOOLSPUN<sup>®</sup> (Art. #671)  
#098 Fisherman 1 ball  
or color of your choice
- LION BRAND<sup>®</sup> double pointed needles size 9 (5.5 mm)
- LION BRAND<sup>®</sup> stitch markers
- LION BRAND<sup>®</sup> cable needle
- LION BRAND<sup>®</sup> large-eyed blunt needle

## SIZE

**Finished Circumference** About 18 in. (45.5 cm),  
stretches to fit.

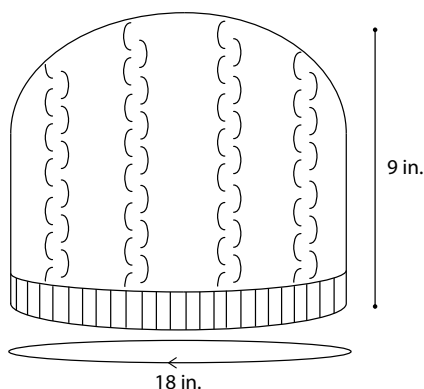

## GAUGE

16 sts = about 4 in. (10 cm) over Rnds 1-9.  
**BE SURE TO CHECK YOUR GAUGE.**

## STITCH EXPLANATION

**2/2 LC (2 over 2 left cross)** Slip 2 sts to cable needle and hold in front, k2, then k2 from cable needle.

**2/2 RC (2 over 2 right cross)** Slip 2 sts to cable needle and hold in back, k2, then k2 from cable needle.

## PATTERN STITCH

**K1, p1 Rib worked in rnds (worked over an even number of sts)**

**Rnd 1:** \*K1, p1; rep from \* to end of rnd.

Rep Rnd 1 for K1, p1 Rib worked in rnds.

## NOTES

1. Hat is worked in one piece in the round on double pointed needles.
2. The edge of the Hat is worked in K1, p1 Rib to create a stretchy fit, then the body of the Hat is worked in a simple cable pattern.

## STEP 1

Cast on 72 sts. Divide sts onto 4 double pointed needles, with 18 sts on each needle. Place marker for beg of rnd. Join by working the first st on left hand needle with the working yarn from the right hand needle and being careful not to twist sts.

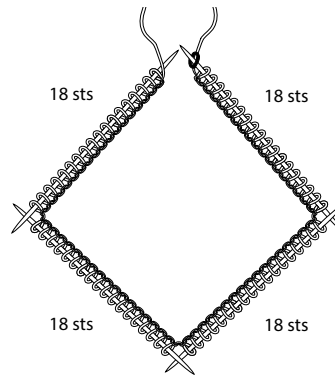

## STEP 2

Work in K1, p1 rib for 2 in. (5 cm).



## STEP 3

### Begin Cable Pattern

**Rnds 1-3:** \*K1, p2, k4, p2; rep from \* around.

**Rnd 4:** \*K1, p2,  $\frac{1}{2}$  LC, p2; rep from \* around.

**Rnds 5-9:** Rep Rnd 1.

**Rnd 10:** \*K1, p2,  $\frac{1}{2}$  RC, p2; rep from \* around.

**Rnds 11 and 12:** Rep Rnd 1.

**Rnds 13-24:** Rep Rnds 1-12.

**Rnds 25 and 26:** Rep Rnd 1.

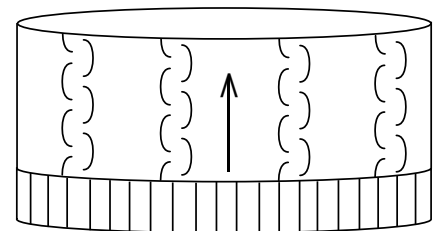

## STEP 4

### Shape Crown (top of Hat)

**Dec Rnd 1:** \*K1, p2tog, k4, p2tog; rep from \* around - you will have 56 sts at the end of this rnd.

**Next Rnd:** \*K1, p1,  $\frac{1}{2}$  LC, p1; rep from \* around.

**Dec Rnd 2:** K1, \*k2tog, k3, k2tog; rep from \* to last 6 sts, k2tog, k3, remove marker, k2tog, place marker for new beg of rnd - 40 sts.

**Dec Rnd 3:** K2tog around - 20 sts.

**Dec Rnd 4:** K2tog around - 10 sts.

Cut yarn, leaving a long yarn tail.

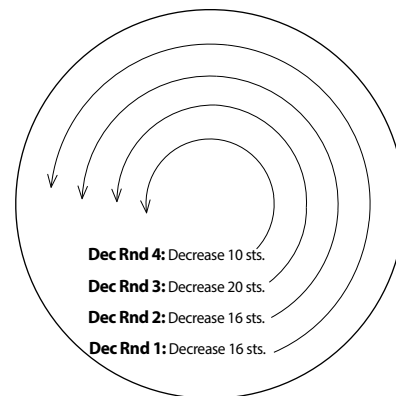

## FINISHING

Thread yarn tail through remaining sts and pull to gather. Knot securely. Weave in ends.

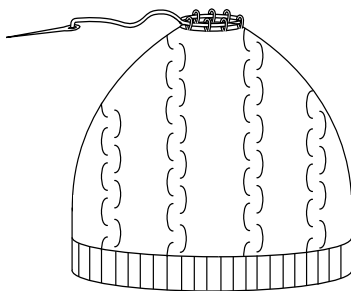

## ABBREVIATIONS

**beg** = begin(ning)

**dec** = decreas(e)(s)(ing)

**k** = knit

**k2tog** = knit 2 stitches together

**p** = purl

**rep** = repeat

**rnd(s)** = round(s)

**st(s)** = stitch(es)