



**Free Knitting Pattern**  
**Lion Brand® Ice Cream Big Scoop**  
**Shorts And Top Set**  
Pattern Number: L60013



# Free Knitting Pattern from Lion Brand Yarn

## Lion Brand® Ice Cream Big Scoop

### Shorts And Top Set

Pattern Number: L60013

**SKILL LEVEL:** [Easy \(Level 2\)](#)

**SIZE:** 12 mos, 24 months (2 yrs)

#### Top

**Circumference at Chest** About 22 (23) in. (56 (58.5) cm)

**Finished Length** About 12 1/2 (14 1/2) in. (32 (37) cm)

#### Shorts

**Finished Waist** About 26 (28) in. (66 (71) cm), without elastic

**Finished Length** About 7 1/2 (9) in. (19 (23) cm)

**Note:** Pattern is written for smallest size with changes for larger sizes in parentheses. When only one number is given, it applies to all sizes. To follow pattern more easily, circle all numbers pertaining to your size before beginning.

**CORRECTIONS:** None as of Jun 13, 2016. To check for later updates, click [here](#).

#### MATERIALS

- 922-206 [Lion Brand Ice Cream Big Scoop: Tutti Frutti](#)

1 1 Ball

- [Lion Brand Knitting Needles- Size 6 \[4.00 mm\]](#)

- [Hiya Hiya Bamboo Circular Knitting Needles Size 5 \(3.75 mm\) 24"](#)

- [Lion Brand Split Ring Stitch Markers](#)

- [Lion Brand Stitch Holders](#)

- [Lion Brand Large-Eye Blunt Needles \(Set of 6\)](#)

- Additional Materials

24 in. (61 cm) length of elastic, 1 in. (2.5 cm) wide

Sewing needle and thread

One small button

*\*Ice Cream Big Scoop (Article #922). 100% Acrylic; package size: 10.00oz/284.00 gr. (1117yds/1022m) pull skeins*



#### GAUGE:

21 sts + 28 rows = 4 in. (10 cm) in St st (k on RS, p on WS) with larger needles and A.

When you match the gauge in a pattern, your project will be the size specified in the pattern and the materials specified in the pattern will be sufficient. The needle or hook size called for in the pattern is based on what the designer used, but it is not unusual for gauge to vary from person to person. If it takes you fewer stitches and rows to make your swatch, try using a smaller size hook or needles; if more stitches and rows, try a larger size hook or needles.

[Making a Gauge Swatch](#)

#### NOTES:

1. Top is worked in 2 pieces – Back and Front.
2. Decreases are worked on Top to create a cute A-line shape.
3. A slit is made at center Back so the Top will fit easily over baby's head!
4. Garter st (k every st on every row) edging is worked around neck and armholes of Top.
5. Legs of Shorts are worked separately, then joined to work the waistband.
6. Waistband is folded to make a casing for the elastic – waist size can be adjusted by cutting the elastic to the correct length.
7. End with a WS row means that the last row you work should be a WS row, and the next row that you are ready to work will be a RS row.

8. When you see '- 12 sts' in the instructions, this lets you know how many sts you will have at the end of that specific row.

## TOP

### FRONT

With straight needles, cast on 68 (70) sts.

**Rows 1-8:** Knit.

**Row 9 (Decrease Row) (RS):** K4, k2tog, k to last 6 stitches, k2tog, k to end of row – you will have 66 (68) sts at the end of this row.

**Rows 10-16:** Beg with a WS (purl) row, work in St st (k on RS, p on WS).

**Rows 17-40:** Rep Rows 9-16 for 3 more times – 60 (62) sts when all rows have been worked.

**Row 41:** Rep Row 9 – 58 (60) sts.

Continue in St st until piece measures about 8 (9) in. (20.5 (23) cm) from beg, end with a WS row as the last row you work.

### Shape Armholes

**Row 1 (RS):** Bind off 4 sts, k to end of row.

**Row 2:** Bind off 4 sts, p to end of row – 50 (52) sts.

**Row 3 (Decrease Row):** K1, k2tog, k to last 3 sts, k2tog, K1 – 48 (50) sts.

**Row 4:** Purl.

Rep Rows 3 and 4 for 3 more times – 42 (44) sts when all decreases have been completed.

Continue in St st for 2 rows.

Rep Row 3 – 40 (42) sts.

Continue in St st until armholes measure about 2 1/2 (3 1/2) in. (6.5 (9) cm), end with a WS row as the last row you work.

### Shape Neck

**Note:** You'll be shaping one side of the front neck at a time.

**First Shoulder Row 1 (RS):** K15 (16) and slip these sts onto a st holder for second side, bind off 10 sts, k to end of row – 15 (16) sts rem.

**Rows 2, 4, 6 and 8:** Purl.

**Row 3:** Bind off 3 sts, k to end of row – 12 (13) sts.

**Row 5:** Bind off 2 sts, k to end of row – 10 (11) sts.

**Row 7:** K2tog, k to end of row – 9 (10) sts.

**Row 9:** K2tog, k to end of row – 8 (9) sts.

**Rows 10-13:** Work in St st.

Bind off.

### Second Shoulder

Return 15 (16) sts from st holder to needles so you are ready to work a WS row.

**Row 1(WS):** Bind off 3 sts, purl to end of row – 12 (13) sts.

**Rows 2, 4 and 6:** Knit.

**Row 3:** Bind off 2 sts, p to end of row – 10 (11) sts.

**Row 5:** P2tog, p to end of row – 9 (10) sts.

**Row 7:** Rep Row 5 – 8 (9) sts.

**Rows 8-11:** Work in St st.

Bind off.

## BACK

Cast on and work same as Front until armholes measure about 1 1/2 (2 1/2) in. (4 (6.5) cm), end with a WS row as the last row you work.

### Divide for Back Slit

#### First Shoulder

**Next Row (RS):** K 20 (21); sl rem sts to a st holder for second side – 20 (21) sts rem for first shoulder.

Continue in St st until armhole measures about 3 1/2 (4 1/2) in. (9 (11.5) cm), end with a RS row as the last row you work.

### Shape Neck

**Next Row (WS):** Bind off 10 sts, p to end of row – 10 (11) sts.

**Next Row:** K to last 2 sts, k2tog – 9 (10) sts.

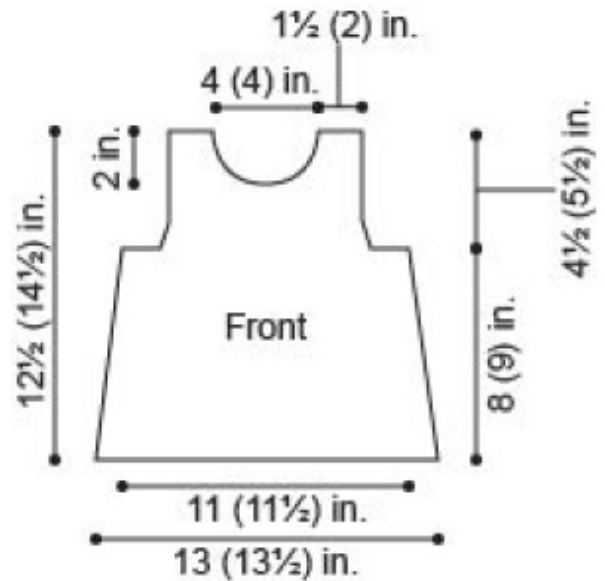

**Next Row:** Purl.

**Next Row:** K to last 2 sts, k2tog – 8 (9) sts.

Continue in St st for 4 rows.

Bind off.

### Second Shoulder

Return 20 (21) sts from holder to needles ready to work a RS row.

Continue in St st until armhole measures same as first shoulder to neck, end with a WS row as the last row you work.

### Shape Neck

**Next Row (RS):** Bind off 10 sts, k to end of row – 10 (11) sts.

**Next Row:** Purl.

**Next Row:** K2tog, k to last end of row – 9 (10) sts.

**Next Row:** Purl.

**Next Row:** K2tog, k to last end of row – 8 (9) sts.

Continue in St st for 4 rows.

Bind off.

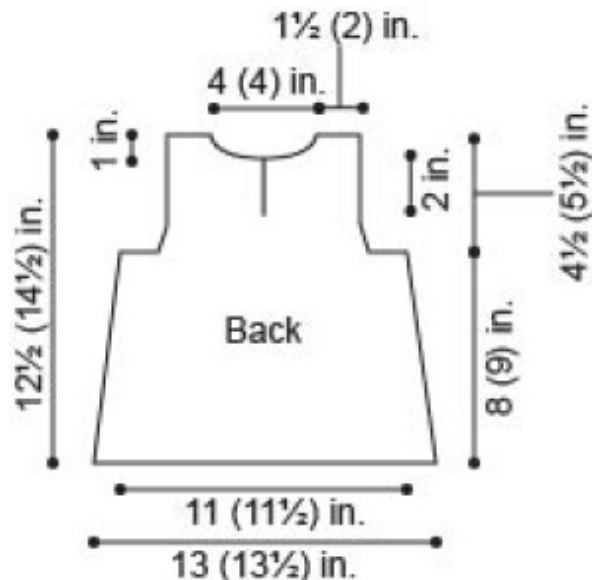

### FINISHING

Sew shoulder seams.

### Neck Edging

From RS with circular needle, and beg at left Back slit, pick up and k70 sts evenly spaced around neck edge, ending at right Back slit.

Working back and forth in rows on circular needle as if working on straight needles, knit 2 rows.

Bind off.

### Armhole Edging

From RS with circular needle, and beg at underarm, pick up and k 52 (62) sts evenly spaced around armhole edge.

Work as for neck edging.

Bind off.

Rep edging on opposite armhole.

Sew side seams, including armhole edging.

Sew button to top of one side of Back slit. Button the Top by inserting the button through the knit fabric.

Weave in ends.

### SHORTS

**Note:** Legs are worked separately beg at the lower edge. The waistband is then worked in one piece across the top of both legs.

### FIRST LEG

With straight needles, cast on 84 (90) sts.

Knit 5 rows.

Beg with a RS (knit) row, work in St st for 10 (14) rows.

### Shape Crotch

**Next Row (RS):** Bind off 4 sts, k to end of row – you will have 80 (86) sts at the end of this row.

**Next Row:** Bind off 4 sts, p to end of row – 76 (82) sts.

**Next Row:** K1, k2tog, k to end of row – 75 (81) sts.

**Next Row:** P1, p2tog, p to end of row – 74 (80) sts.

Rep last 2 rows until 70 (74) sts rem.

Continue in St st until piece measures about 4 1/2 (5) in. (11.5 (12.5) from beg of crotch shaping, end with a WS row as the last row you work.

Cut yarn and slip sts for First Leg onto a st holder.

### SECOND LEG

Cast on and work same as for First Leg, but do NOT place sts onto a st holder.

### Waistband

**Next Row (RS):** With circular needle, knit across sts of Second Leg, then knit across sts of First Leg from st holder – 140 (148) sts.

Place a marker for beg of rnd and join by working the first st on the left hand needle with the working yarn from the right hand needle.

**Rnds 1-7:** Knit.

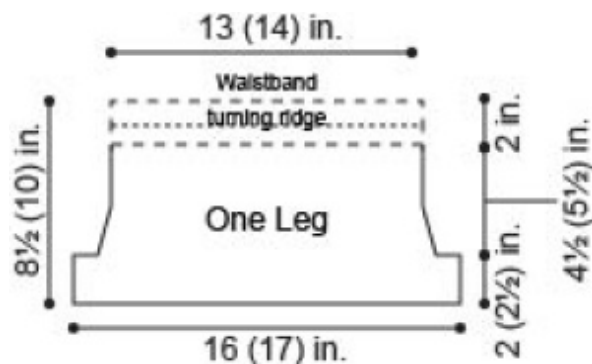

**Rnd 8:** Purl to make a turning ridge.

**Rnds 9-16:** Knit.

Bind off.

## FINISHING

Sew leg and crotch seams. Fold waistband to WS along turning ridge to make casing and sew in place, leaving an opening to insert elastic. Cut elastic to waist size, then thread through casing. **Tip:** Attach a large safety pin to one end of the elastic to make threading easier. With sewing needle and thread, seam ends of elastic. Sew opening in casing closed.

Weave in ends.

<b>ABBREVIATIONS / REFERENCES</b>	
Click for explanation and illustration	
<u>beg = begin(s)(ning)</u>	<u>k = knit</u>
<u>k2tog = knit 2 together</u>	<u>p = purl</u>
<u>p2tog = purl 2 together</u>	<u>rem = remain(s)(ing)</u>
<u>rep = repeat(s)(ing)</u>	<u>rnd(s) = round(s)</u>
<u>RS = right side</u>	<u>sl = slip</u>
<u>St st = Stockinette stitch</u>	<u>st(s) = stitch(es)</u>
<u>tog = together</u>	<u>WS = wrong side</u>

Learn to knit instructions: <http://learnToKnit.LionBrand.com>

---

Every effort has been made to have the knitting and crochet instructions accurate and complete. We cannot be responsible for variance of individual knitters and crocheters, human errors, or typographical mistakes.

We want your project to be a success! If you need help with this or any other Lion Brand pattern, e-mail support is available 7 days per week. Just click [here](#) to explain your problem and someone will help you!

**For thousands of free patterns, visit our website [www.LionBrand.com](http://www.LionBrand.com)**

**To order visit our website [www.lionbrand.com](http://www.lionbrand.com) or call: (800) 258-YARN (9276) any time!**

**When in New York City, visit the Lion Brand Yarn Studio where we have the largest selection of our yarns anywhere and over 100 classes and events monthly.  
34 West 15th Street, NY, NY 10011**

Copyright ©1998-2016 Lion Brand Yarn Company, all rights reserved. No pattern or other material may be reproduced -- mechanically, electronically, or by any other means, including photocopying -- without written permission of Lion Brand Yarn Company.