

ASSEMBLING INSTRUCTION

DESK TABLE

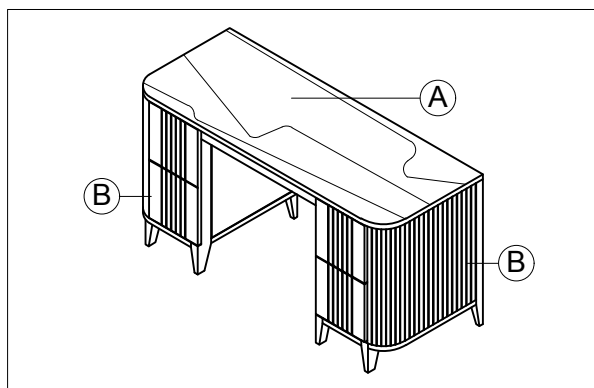

Pre Assembly :

- Please read all instructions before beginning assembly
- Place all parts on a carpet or foam in shipping box. Find the letter (A,B,C,...) or number (1,2,3,...) on each part and check with below part list to ensure we have all components.
- Save all packing materials until assembly is complete to avoid accidentally discarding smaller parts or hardware.
- This cart requires one people to do assembly.

Part Included :

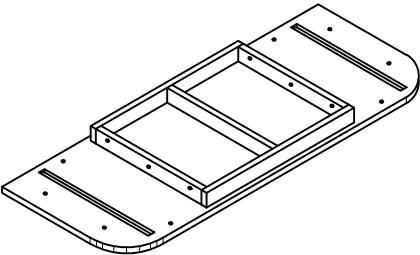
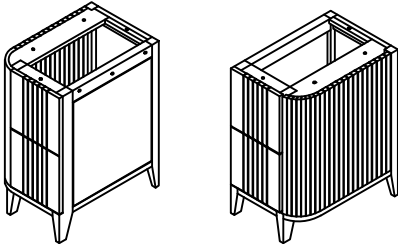
A - Top Table - 1 pc	B - Desk L/R - 2 pcs
	

Hardware Enclosed :

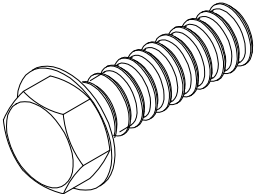
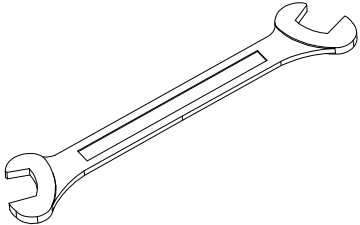
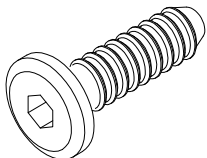
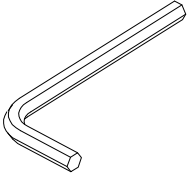
C - Hexagonal Bolt - 6 pcs	D - Wrench - 1 pc
	
E - JCBC Bolt - 8 pcs	F - Allen Key - 1 pc
	

Assembly Instructions :

1. Lay Desk Left and Right (B) onto clean smooth surface as carpet or cardboard.
Please note the indicating stickers or letter for homing guidance.
2. Attach Top Table (A) to the Desk (B) by aligning into wooden holes.
2.1 Secured by Hexagonal Bolt (C) and Tighten by using Wrench (D) for outside holes.

See diagram below

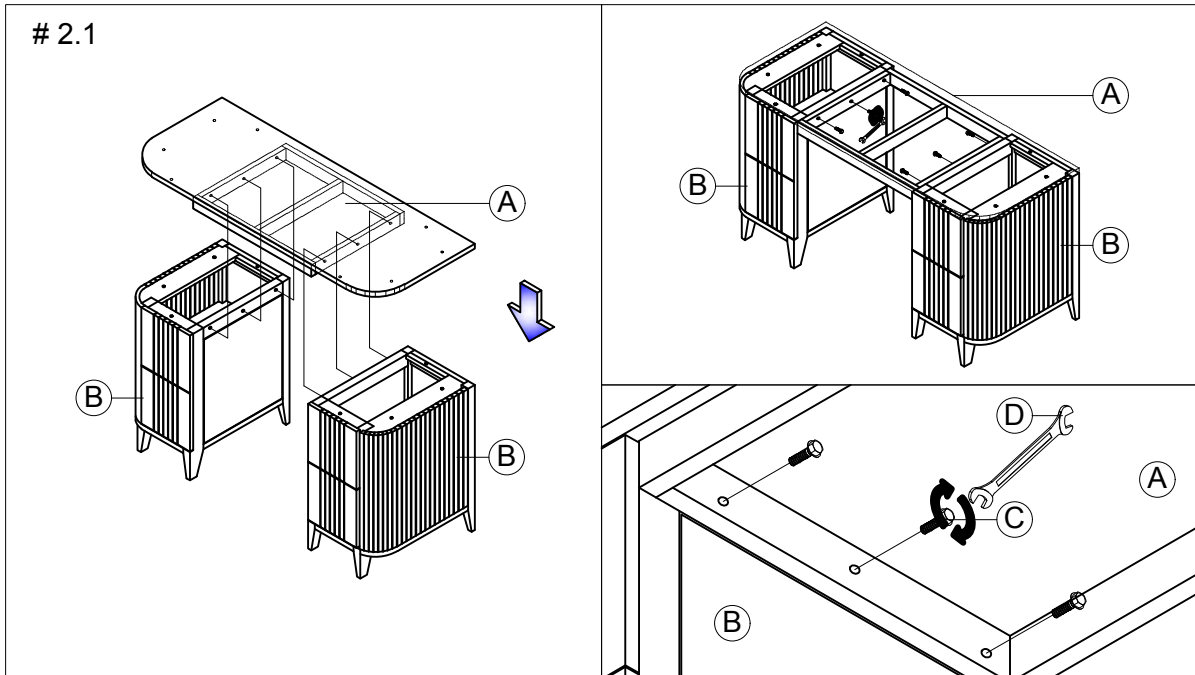

- 2.2 Secured by JCBC Bolt (E) and Tighten by using Allen Key (F) for inside holes.

See diagram below

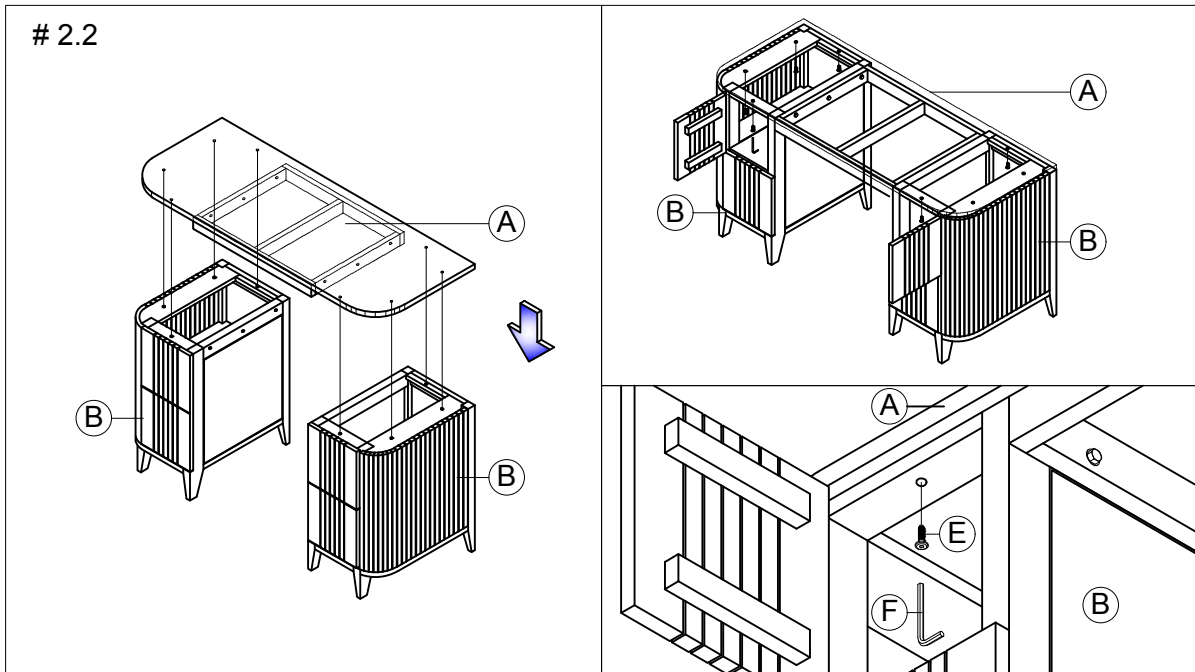

Care Instructions :

- Hardware may loosen over time. Periodically check to make sure all components are tight. Re-tighten if necessary.
- Dust with soft dry cloth.
- Avoid abrasive cleaners. If a cleaner is needed, use a mild-cleaner spray and blot with an absorbent cloth.