

Installation, Operation and Service Instructions

INFRARED HEATER



Series ETSV Infrared Heater Two-Stage



WARNING

Improper installation, adjustment, alteration, service or maintenance can cause property damage, injury or death.

Read the installation, operating and maintenance instructions thoroughly before installing or servicing this equipment.

OWNER

Retain this Manual & ensure available for Service. Improper installation, adjustment, alteration, service or maintenance can cause injury, death or property damage.

Read the installation, operation and service instructions thoroughly before installing or servicing this equipment.

FOR YOUR SAFETY

Do not store or use gasoline or other flammable vapors and liquids in the vicinity of this or any other appliance.

If you smell gas:

1. Open windows
2. Don't touch electrical switches
3. Extinguish any open flame
4. Immediately call your gas supplier

INSTALLER

Provide Manual to owner upon completion of installation! Read and thoroughly understand these Instructions before attempting any installation.

Canada: 563 Barton Street, Stoney Creek, Ontario L8E 5S1

USA: 315 N Madison Street, Fortville, IN 46040

www.irenergy.ca

CAUTION - FIRE OR EXPLOSION HAZARD

Maintain clearance to combustible constructions as further specified in this manual. Failure to do so could result in a serious fire hazard. Heaters should not be located in hazardous atmospheres containing flammable vapors or combustible dusts. Signs should be provided in storage areas specifying maximum safe stacking height.

CAUTION - MECHANICAL HAZARD

This equipment expands and contracts with each operating cycle. The gas connection, suspension hardware, and the installation itself must safely allow this movement. Failure to do so could result in serious fire or explosion hazard.

CAUTION - FIRE OR EXPLOSIONS HAZARD

This heater is equipped with an automatic ignition device. Do not attempt to light the burner by hand. Failure to comply could result in a serious fire and personal injury hazard.

CAUTION - MECHANICAL HAZARD

Do not use high pressure (above ½ psi, 60 mbar) to test the gas supply system with the burners connected. Failure to do so could result in damage to the burner and its control components requiring replacement.

CAUTION - SERVICE LIFE RISK

Do not install equipment in atmosphere containing halogenated hydrocarbons or other corrosive chemicals. Failure to do so may lead to premature equipment failure and invalidation of the warranty. Additionally, it is recommended that the equipment be installed with a downward slope, away from the burner. The rate of declination should be ¼" (6mm) in height per 10' (3m) in length to allow the start-up condensation to drain.

CALIFORNIA PROPOSITION 65

This appliance, its related accessories and by-product of operation, contain chemicals known to the State of California to cause cancer and birth defects or other reproductive harm. For more information go to www.P65Warnings.ca.gov.

WARNING - CARBON MONOXIDE POISONING HAZARD

Failure to follow the steps outlined below for each appliance connected to the venting system being placed into operation could result in carbon monoxide poisoning or death. The following steps shall be followed for each appliance connected to the venting system being placed into operation, while all other appliances connected to the venting system are not in operation:

1. Seal any unused openings in the venting system.
2. Inspect the venting system for proper size and horizontal pitch, as required in the *National Fuel Gas Code*, ANSI Z223.1/NFPA 54 or the *Natural Gas and Propane Installation Code*, CSA B149.1 and these instructions. Determine that there is no blockage or restriction, leakage, corrosion and other deficiencies which could cause an unsafe condition.
3. As far as practical, close all building doors and windows and all doors between the space in which the appliances(s) connected to the venting system are located and other spaces of the building.
4. Close fireplace dampers.
5. Turn on clothes dryers and any appliance not connected to the venting system. Turn on any exhaust fans, such as range hoods and bathroom exhausts, so they are operating at maximum speed. Do not operate a summer exhaust fan.
6. Follow the lighting instructions. Place the appliance being inspected into operation. Adjust the thermostat so appliance is operating continuously.
7. Test for spillage from draft hood equipped appliances at the draft hood relief opening after 5 minutes of main burner operation. Use the flame of a match or candle.
8. If improper venting is observed during any of the above tests, the venting system must be corrected in accordance with the *National Fuel Gas Code*, ANSI Z223.1/NFPA 54 and/or *Natural Gas and Propane Installation Code*, CSA B149.1.
9. After it has been determined that each appliance connected to the venting system properly vents when tested as outlined above, return doors, windows, exhaust fans, fireplace dampers and any other gas-fired burning appliance to their previous conditions of use.

WARNING

Certain materials or items, when stored under the heater, will be subjected to radiant heat and could be seriously damaged. Children and adults should be alerted to the hazards of high surface temperatures and should stay away to avoid burns or clothing ignition. Young children should be carefully supervised when they are in the same space as the heater. Clothing or other flammable materials should not be hung from the heater, or placed on or near the heater.

WARNING - RESIDENTIAL DWELLINGS

Certain materials or items, when stored under the heater, will be subjected to radiant heat and could be seriously damaged. Children and adults should be alerted to the hazards of high surface temperatures and should stay away to avoid burns or clothing ignition. Young children should be carefully supervised when they are in the same space as the heater. Clothing or other flammable materials should not be hung from the heater, or placed on or near the heater.

SAFETY FEATURES

This heater utilizes an airflow switch as blocked vent shut off system. This system is designed to prevent the operation of the appliance if a fresh air supply is blocked or if the flue exhaust is blocked. If this system fails to operate DO NOT ATTEMPT ADJUSTMENTS. Disconnect power to the appliance and contact a qualified service person.

Contents

Contents	4
Introduction	5
Installation Codes	5
General Specifications	6
Gas Supply	6
Electrical Supply	6
Flue and Outside Air Connection	6
Configurations	6
High Altitude	6
Dimensional Chart	7
ETSV 40	7
ETSV 80	8
Components	9
Heater Components for ETSV 40	9
Heater Components for ETSV 80	11
Installation Requirements	13
Clearance to Combustibles	13
Heater Mounting	14
Rigid Surface Mounting	14
Installation Instructions	16
Installation Sequence ETSV 40	16
Installation Sequence ETSV 80	31
Gas Piping	52
Installation / Code Requirements	52
Electrical Wiring	53
General Requirements	53
Multiple Heater Wiring (Thermostat)	54
External Wiring Options (Outdoor Installation Only)	55
Multiple Heater Wiring (Switch P/N EE020)	56
Vented Operation	57
General Requirements	57
Un-Vented Operation	57
Vented Operation	58
Horizontal Venting	58
Vertical Venting	58
Common Vertical Venting	58
Combustion Air Supply (Optional)	59
Outdoor Installation	60
Lighting & Shutdown Instructions	60
Lighting	60
Shut Down	60
Maintenance & Trouble Shooting	61
Troubleshooting Chart	62
Replacement Parts List	63
Warranty	64

Introduction

IR Energy is a company in the infrared heating industry founded on the principles of product quality and customer commitment. Quality commitments are evidenced by superior design, a regard for design detail and an upgrade of materials wherever justifiable. Customer commitment is apparent through our ready responses to market demands and a never ending training and service support program for and through our distributor network. IR Energy offers its 20 years of infrared expertise in a cost effective unitary heater design as culmination of that commitment. **Series ETSV** models are low intensity infrared heaters that are easy to install and maintain, and which were engineered with significant input from our customers. They are designed to provide economical operation and trouble-free service for years to come.

Important

These instructions, the layout drawing, local codes and ordinances, and applicable standards such as to gas piping and electrical wiring comprise the basic information needed to complete the installation, and must be thoroughly understood along with general building codes before proceeding.

Only personnel who have been trained and understand all applicable codes should undertake the installation. IR Energy Representatives are Factory Certified in the service and application of this equipment and can be called on for helpful suggestions about installation.

Installation Codes

Installations must comply with local building codes, or in their absence, the latest edition of the national regulations and procedures as listed below.

General Installation and Gas Codes

Heaters must be installed only for use with the type of gas appearing on the rating plate, and the installation must conform to the National Fuel Gas Code, ANSI Z223.1/NFPA 54 in the USA and CSA B149.1 and B149.2 Installation Codes in Canada.

This heater is approved for indoor and outdoor installation.

Public Garage Installation

Installation in public garages must conform to the Standard for Parking Structures, NFPA-88A or Standard for Repair Garages, NFPA 88B, in the USA and CSA B149.1 and B149.2 Installation Codes in Canada.

Parking Structures

Technical requirements are outlined in ANSI/NFPA 88B (USA)

Gas Supply Lines

Gas supply pipe sizing must be in accordance with the National Fuel Gas Code, ANSI Z223.1/NFPA 54 in the USA and CSA B149.1 and B149.2 Installation Codes in Canada. 1/8" NPT plugged tap must be installed in the gas line connection immediately upstream of the burner farthest from the gas supply meter to allow checking of system gas pressure.

Electrical

All heaters must be electrically grounded in accordance with the National Electric Code, ANSI/NFPA 70 in the USA, and the Canadian Electric Code, CSA C22.1 in Canada, and must comply with all local requirements.

Venting

Refer to the National Fuel Gas Code, ANSI Z223.1/NFPA 54 in the US and CSA B149.1 and B149.2 Installation Codes in Canada for proper location, sizing and installation of vents as well as information on clearance requirements when penetrating combustible walls for venting purposes.

General Specifications

Gas Supply

Inlet Pressure

	Natural Gas	Propane Gas
Minimum:	5.0" W.C.	11.5" W.C.
Maximum:	14.0" W.C.	14.0" W.C.

Manifold Pressure

ETSV 40, ETSV 80

	Natural Gas	Propane Gas
High Rate:	3.3" W.C.	10.2" W.C.
Low Rate:	1.5" W.C.	4.2" W.C.

Inlet Connection

	Natural Gas	Propane Gas
	½" Female NPT	½" Female NPT

Electrical Supply

120 VAC 60Hz. 1Amp: 36" Cord with grounded 3 prong plug.

Flue and Outside Air Connection

4" O.D. male connection for flue adapter and outside air (optional) provided at the heater

Configurations

Natural gas

		ETSV 40	ETSV 80
Heat Input	BTU/hr	38,500	80,000
Partial Heat Input	BTU/hr	23,000	50,000

Propane

		ETSV 40	ETSV 80
Heat Input	BTU/hr	38,500	79,000
Partial Heat Input	BTU/hr	23,000	49,000

High Altitude

When installing this appliance over 4500 ft. above sea level in Canada, the appliance must be properly de-rated and installed according to local codes. In the absence of local codes the appliance must be de-rated in accordance with the most recent CSA - B149 code. In the United States for installations over 2000ft above sea level the appliance must be installed in accordance with the Current National Fuel Gas Code, ANSI Z223.1/NFPA 54. High altitude conversion kits are available, contact manufacturer for more details.

Dimensional Chart

ETSV 40

Note: All dimensions are in inches.

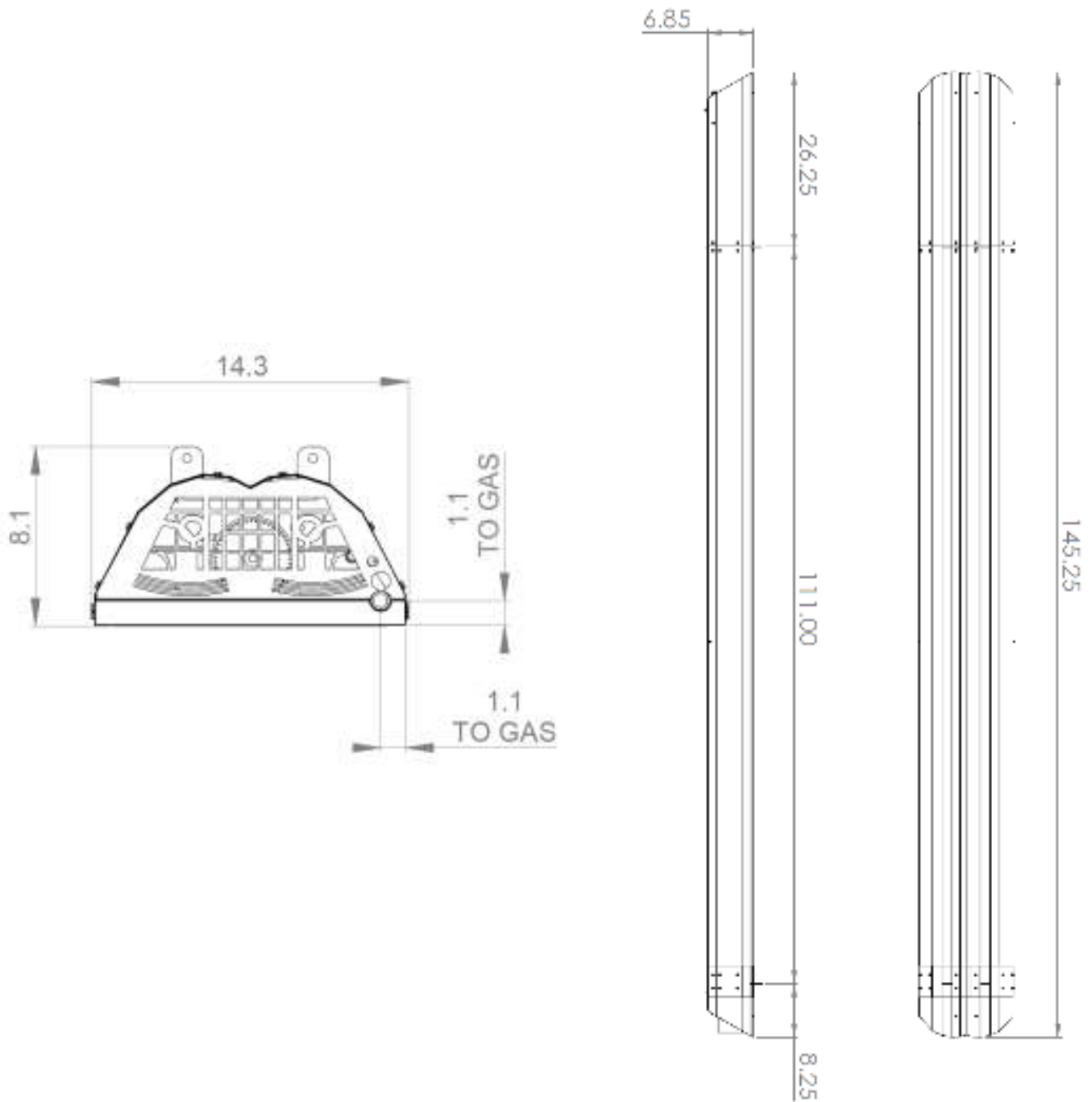

Dimensional Chart

ETSV 80

Note: All dimensions are in inches.

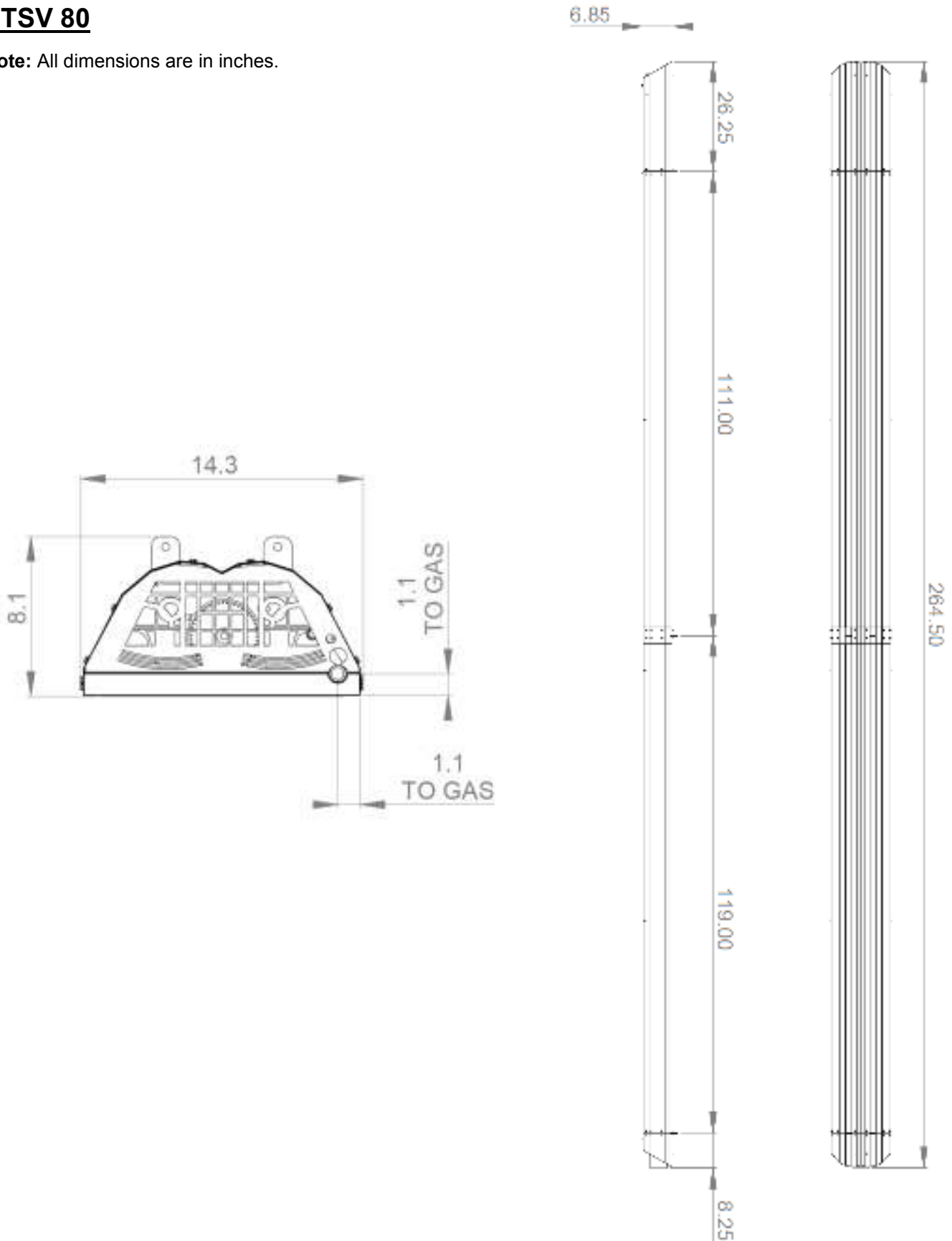

Components

Heater Components for ETSV 40



Burner Head
(with Service Cover)

5/16 Nut QTY (4)

5/16 Lock Washer QTY (4)

Gasket QTY (1)



#8-32 x 3/8"
Screws
QTY (70)



Spacer
1/4" x 1/8"
QTY (8)

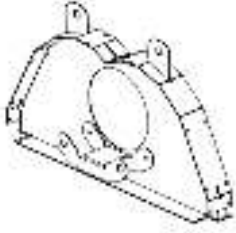

Burner Hanger
QTY (1)

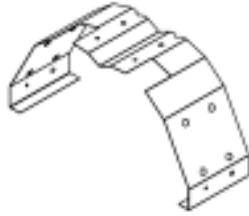

Canopy
QTY (1)



#8-32 x 3/8"
Machine Screws
QTY (2)

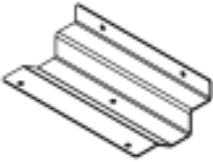

Exhaust Support
QTY (1)



Exhaust Grill
QTY (1)

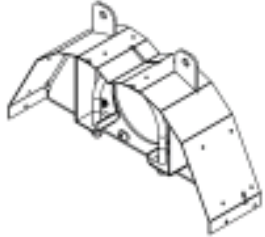

Vent Hanger
QTY (1)



Grill
QTY (1)



Exhaust Cover
QTY (1)

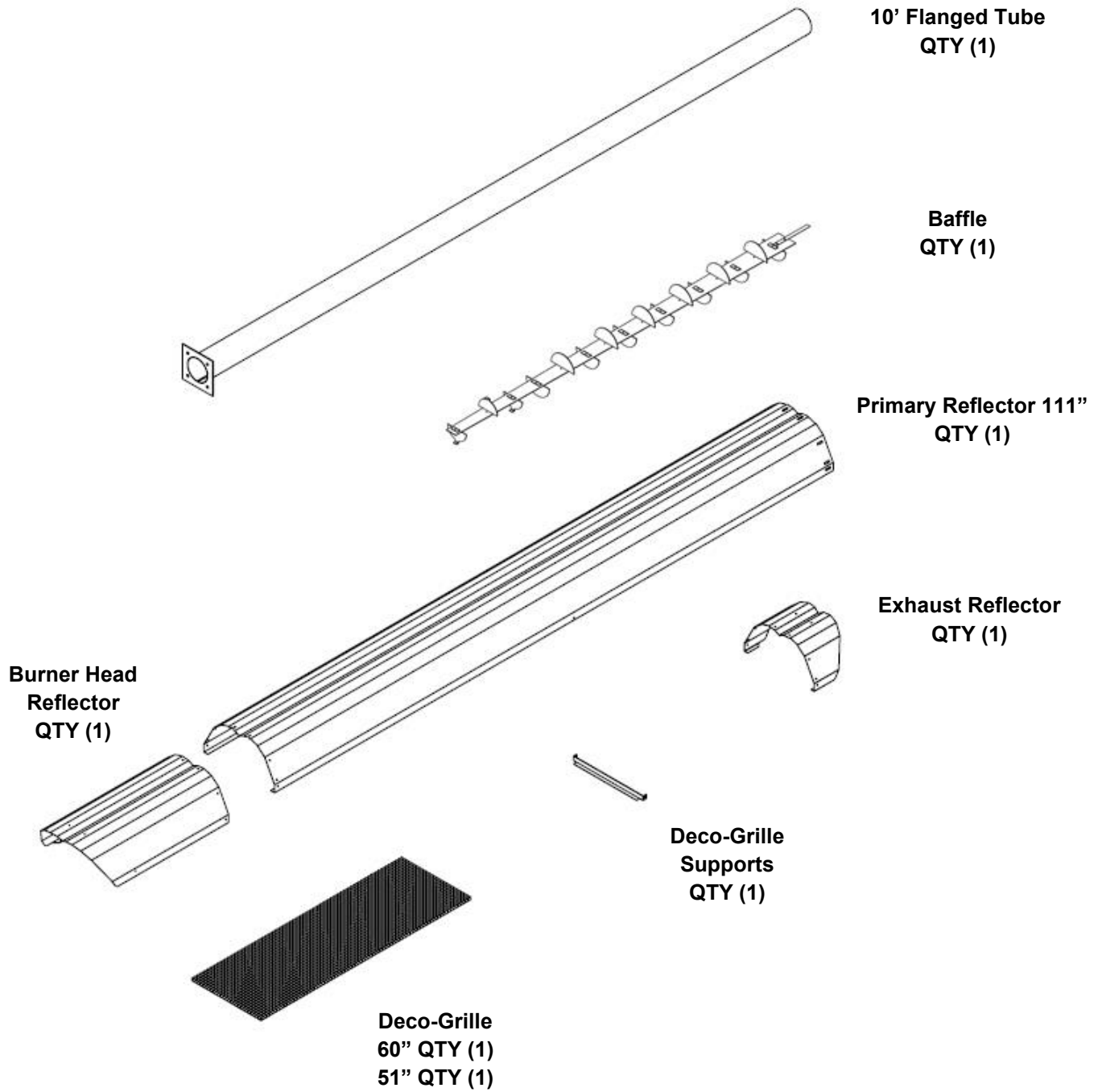

Components

Heater Components for ETSV 80

Burner Head
(with Service Cover)

5/16 Nut QTY (4)

5/16 Lock Washer QTY (4)

Gasket QTY (1)

#8-32 x 3/8" Screws
QTY (70)

Spacer
1/4" x 1/8"
QTY (8)

Burner Hanger
QTY (1)

Middle Hanger
QTY (1)

#8-32 x 3/8" Machine Screws
QTY (2)

Coupling
QTY (1)

Exhaust Grill
QTY (1)

Vent Hanger
QTY (1)

Canopy
QTY (1)

Exhaust Support
QTY (1)

Exhaust Cover
QTY (1)

Grill
QTY (1)

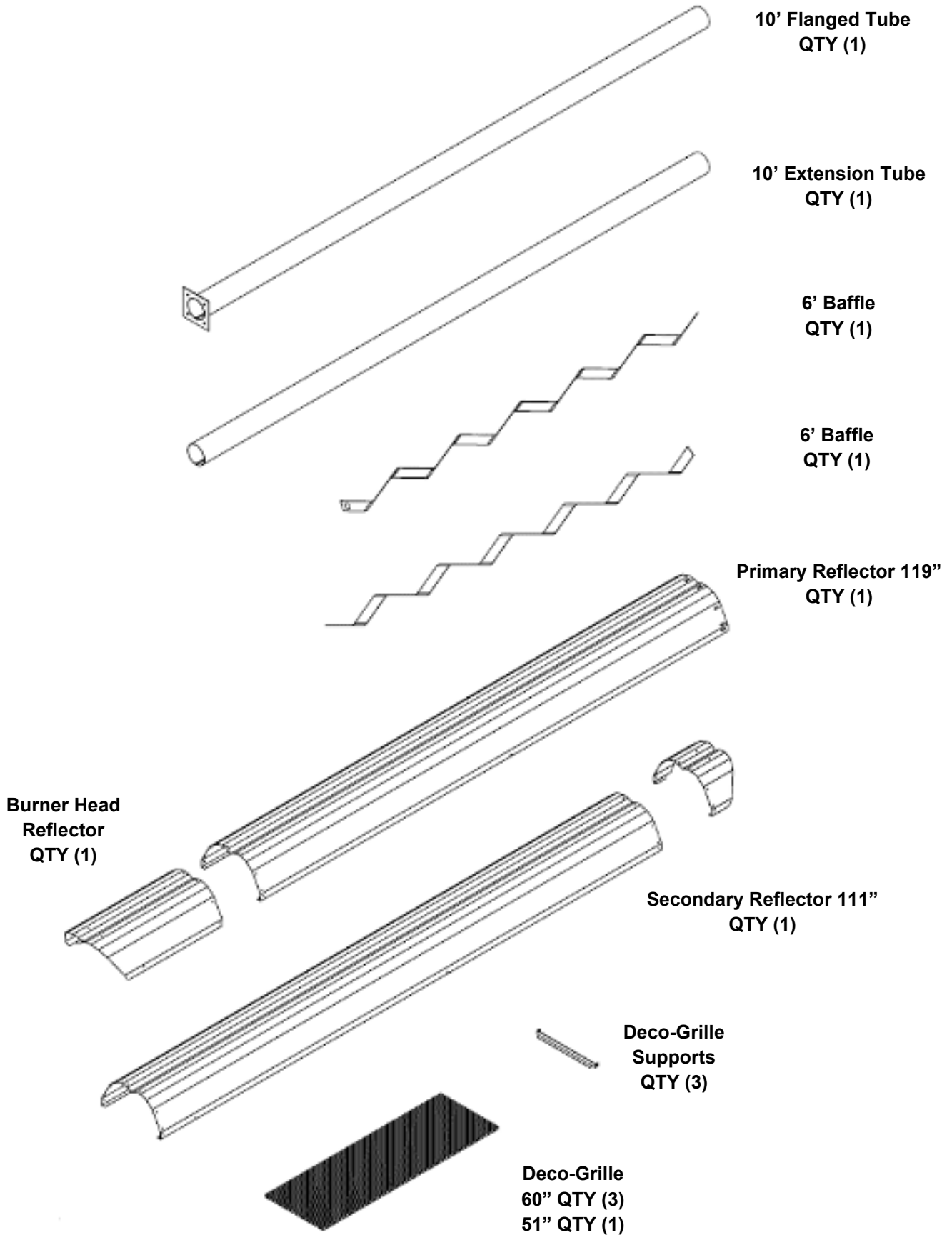

Installation Requirements

Clearance to Combustibles

A general clearance of 18" (0.5 m) in every direction is recommended for servicing around each Burner. This ensures adequate air flow in and around the Heating System.

In addition to this it is very important to observe the minimum clearance to combustibles at all times to avoid any possibility of property damage or personal injury.

Table below lists the minimum clearance to combustible materials for various installation configurations. Additional clearance may be required for glass, painted surfaces and other materials which may be damaged by radiant or convective heat.

Combustible materials are considered to be wood, compressed paper, plant fibres, plastics, Plexiglas or other materials capable of being ignited and burned. Such materials shall be considered combustible even though flame-proofed, fire-retardant treated or plastered.

Adequate clearance to sprinkler heads must be maintained. **NOTE:** Sprinkler head heat fuse link performance may alter with age.

The stated clearance to combustibles represents a surface temperature of 90°C (50°F) **above** room temperature. Building materials with low heat tolerance (such as plastics, vinyl siding, canvas, tri-ply, etc.) may become subject to degradation at lower temperatures. It is the installer's responsibility to ensure that adjacent materials are protected from degradation.

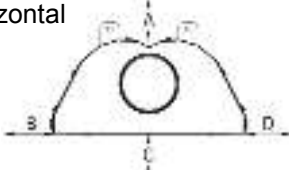
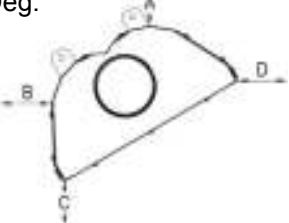
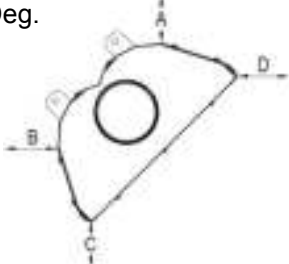
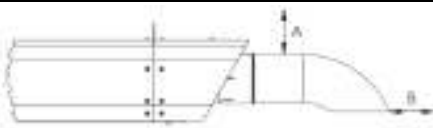
Reflector Configurations	Dim	ETSV 40	ETSV 80
Horizontal 	A	3"	2"
	B	18"	26"
	C	54"	64"
	D	18"	26"
30 Deg. 	A	4"	4"
	B	4"	6"
	C	46"	58"
	D	34"	36"
45 Deg. 	A	6"	4"
	B	4"	4"
	C	44"	58"
	D	38"	50"
	A	6"	6"
	B	16"	16"
Vent End	End	18"	18"

Heater Mounting

The heater can be mounted in a variety of ways, using a combination of chains or mounting brackets. It is critical that the heater is prevented from swaying and putting stress on the gas connection. Also, be sure to check local codes for seismic bracing requirements for outdoor heating equipment.

Note: Minimum mounting height is 7' in Canada and 8' in the US.

Rigid Surface Mounting

In order to allow for lateral tubing expansion in the case of rigid mounting, the burner hanger must be **free** and the rest of the hangers must be **fixed**, as outlined below.

ETSV 40





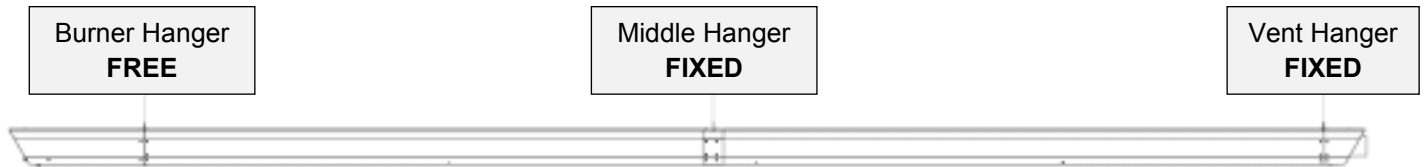

ETSV 80

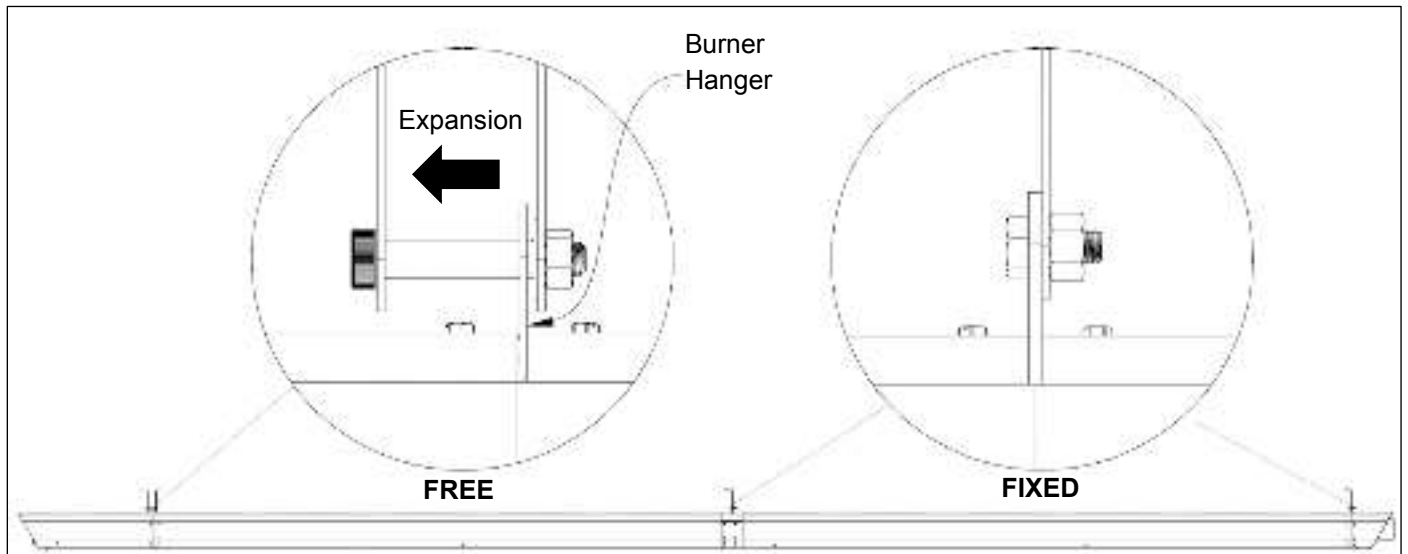

Note: It is crucial to position the free hanger such that the heater may expand in the direction of the burner. See diagram below for more details.

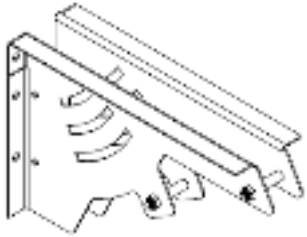
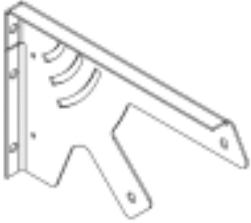
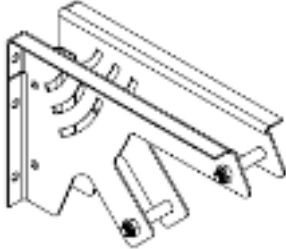

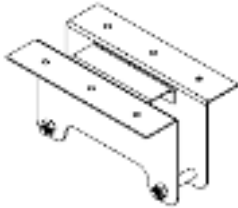
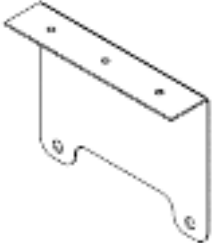
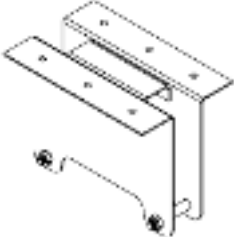
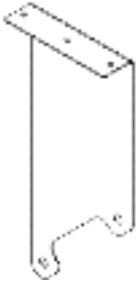
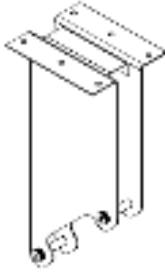
For ceiling and wall mount applications, optional hangers are available:

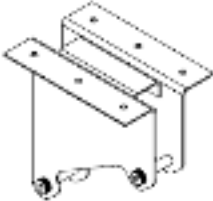
Fixed	Free
Wall Mount	
<p>CR139L/R</p> 	<p>CR205</p> 
<p>CR182L/R</p> 	<p>CR221</p> 
Ceiling Mount	
<p>CR135</p> 	<p>CR206</p> 
<p>CR134</p> 	<p>CR207</p> 
<p>CR181L/R</p> 	<p>CR222</p> 
<p>CR223L/R</p> 	<p>CR224</p> 

Installation Instructions

Installation Sequence ETSV 40

Generally, there is no unique sequence for installation of the burner or heat exchanger. A review of the job site will usually indicate a logical installation order. However, time and expense can be saved if installation is begun at the most critical dimension, watching for interference from overhead beams etc.

It is **RECOMMENDED** to follow the assembly sequence shown in the following pages for free hanging installation.

Step 1:

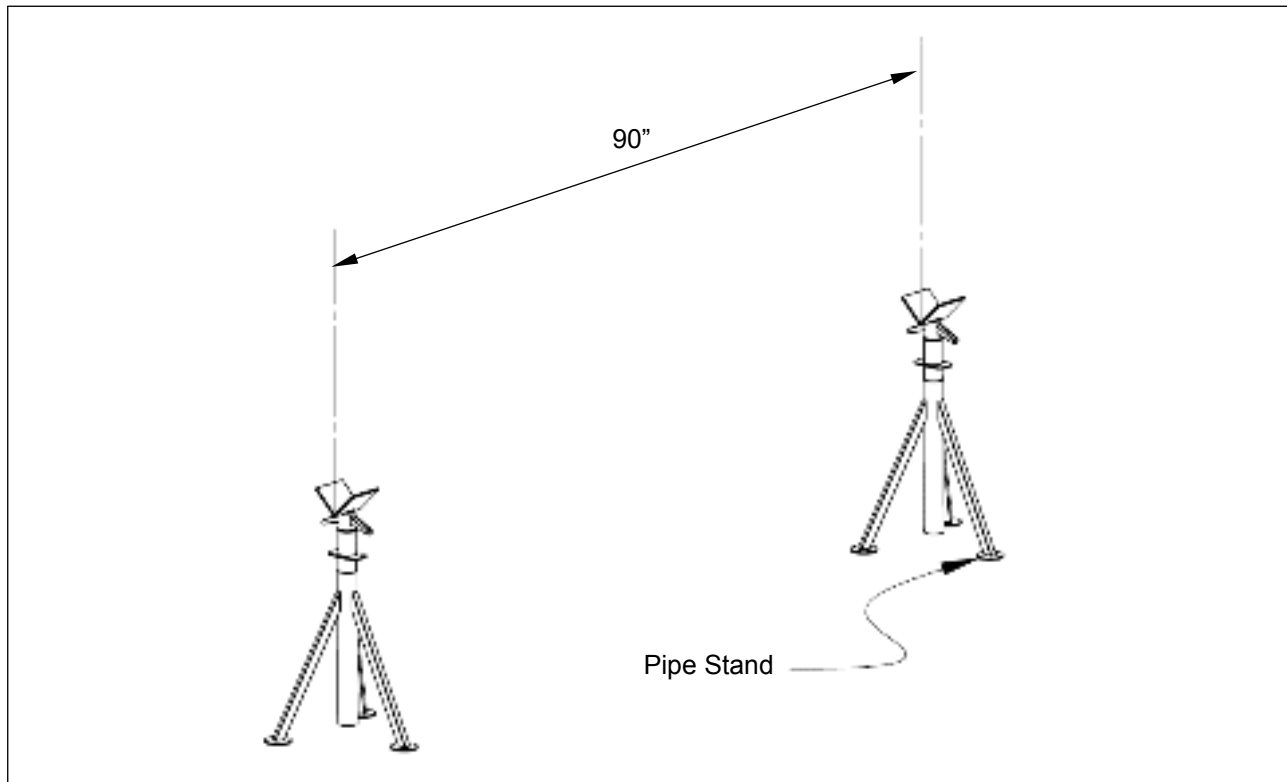

Step 2:

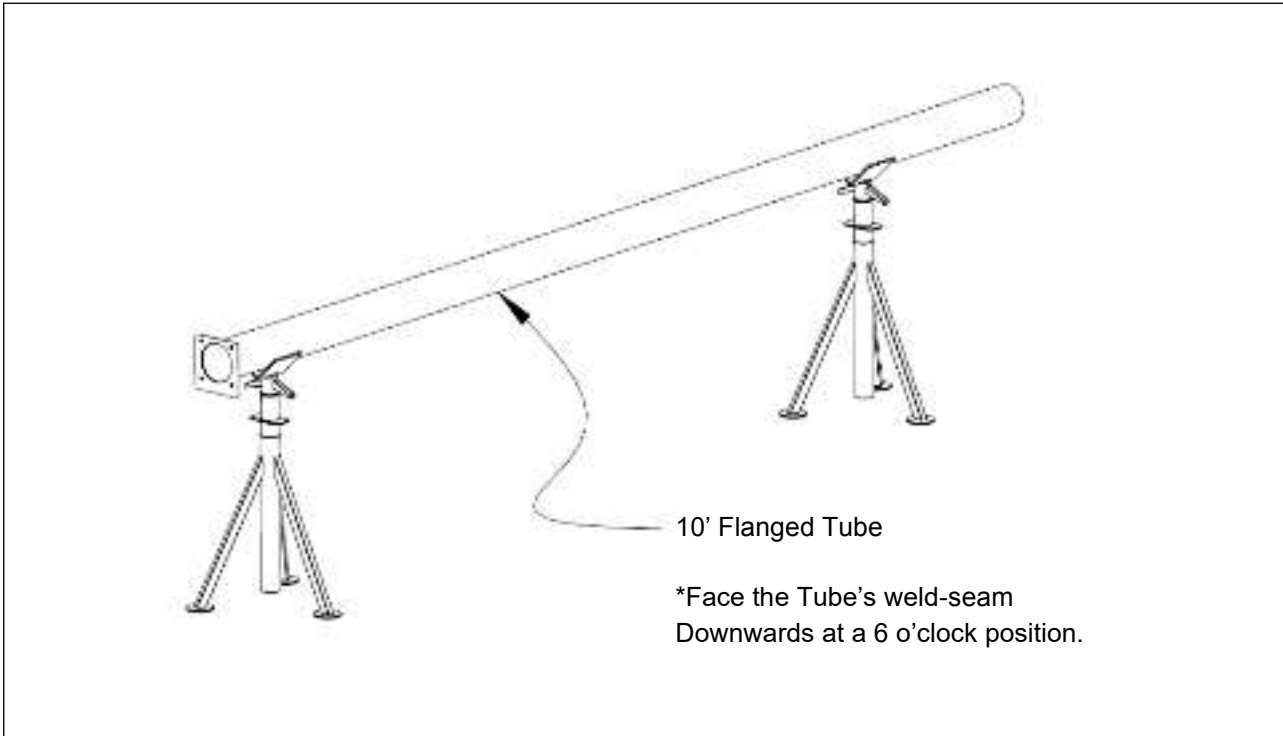

Step 3:

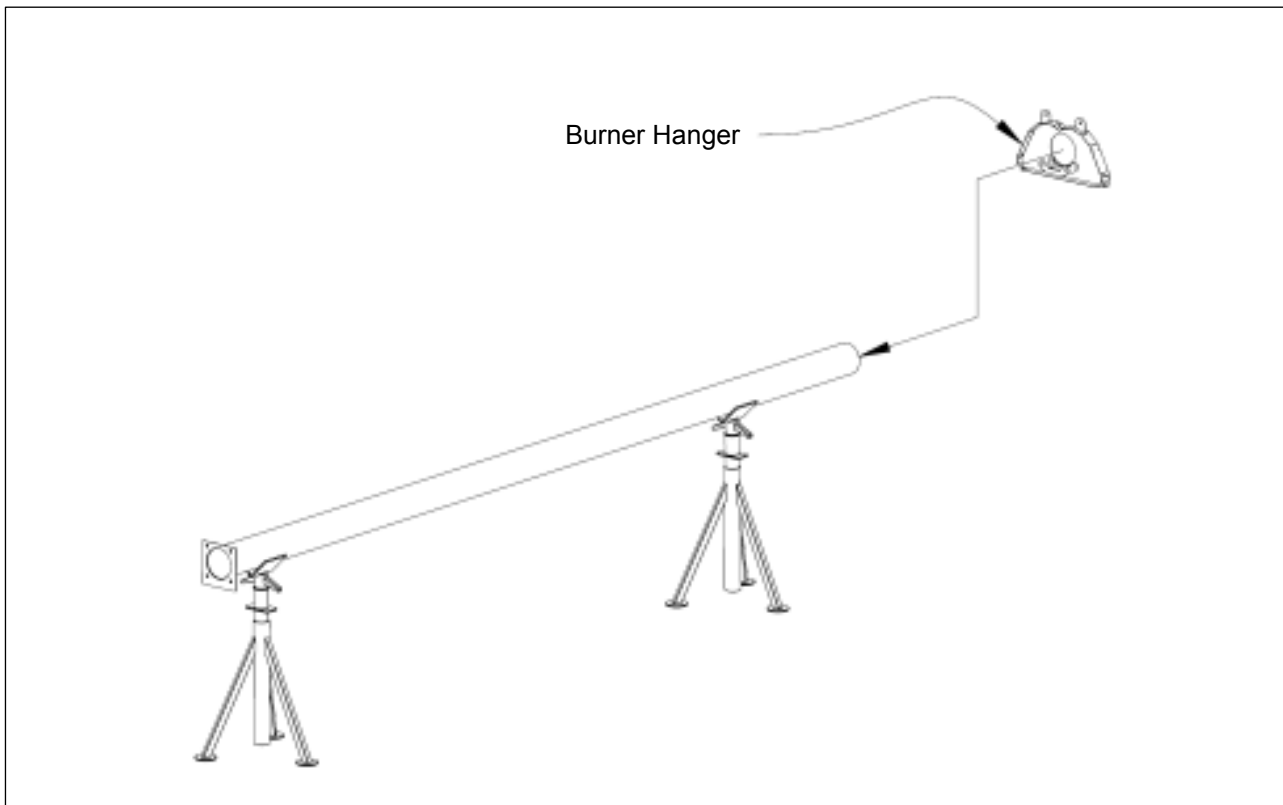

Step 4:

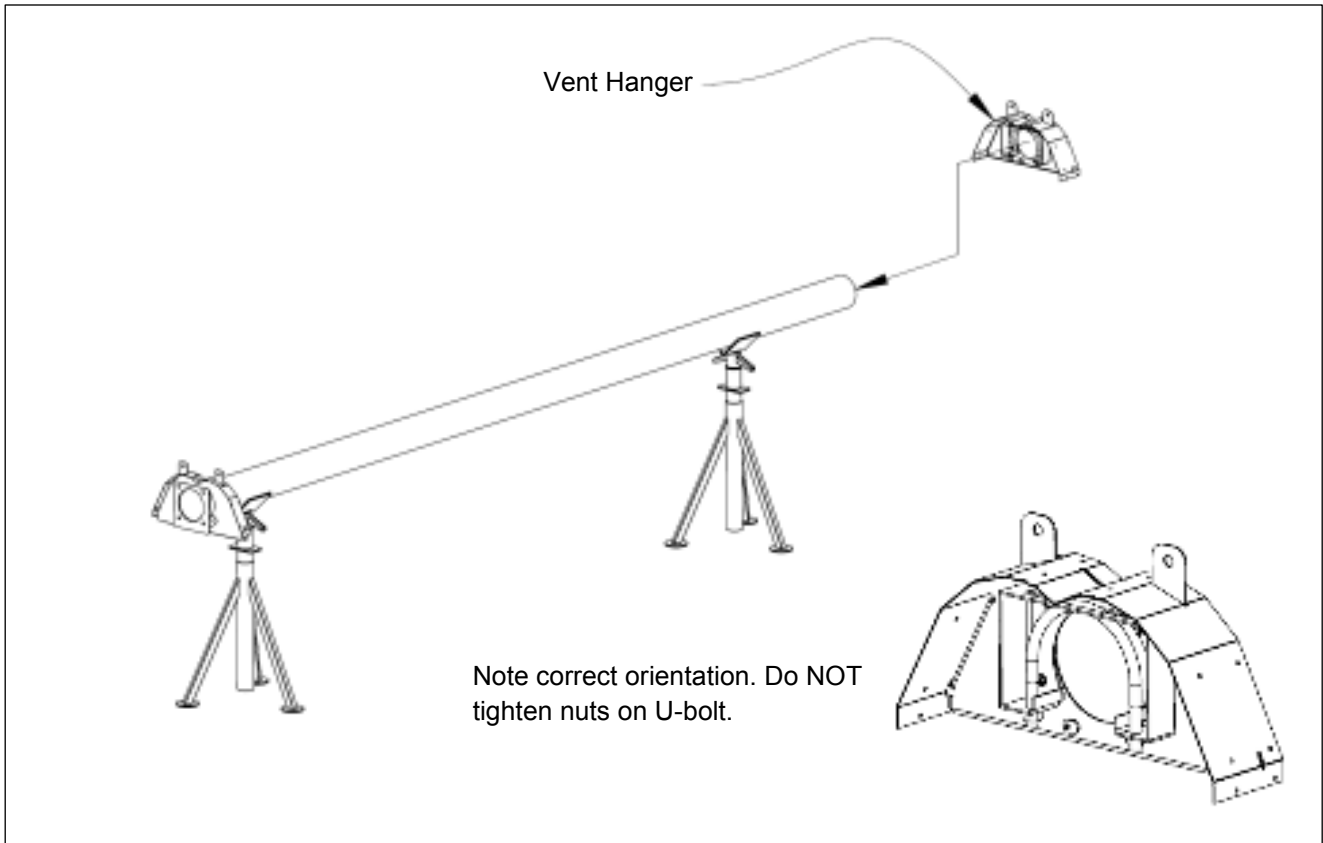

Step 5:

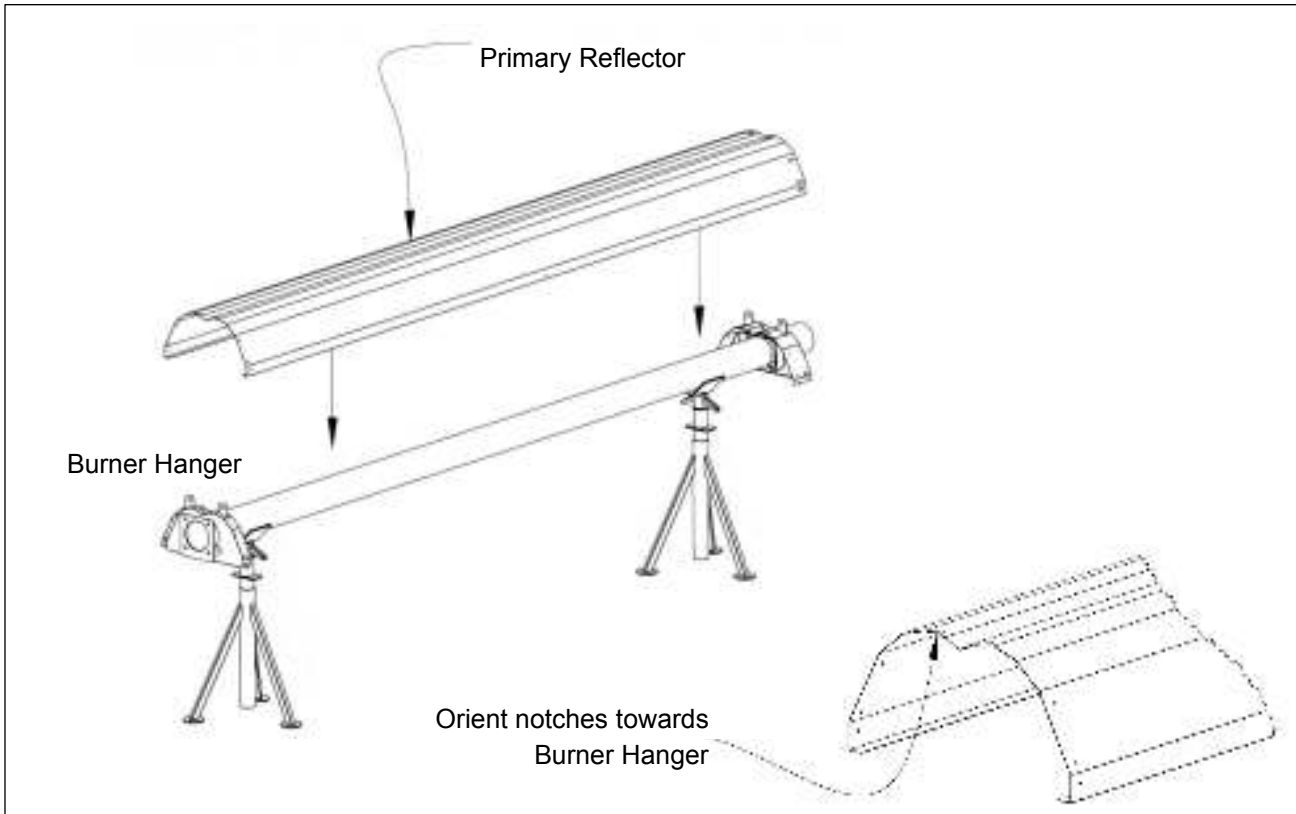

Step 6:

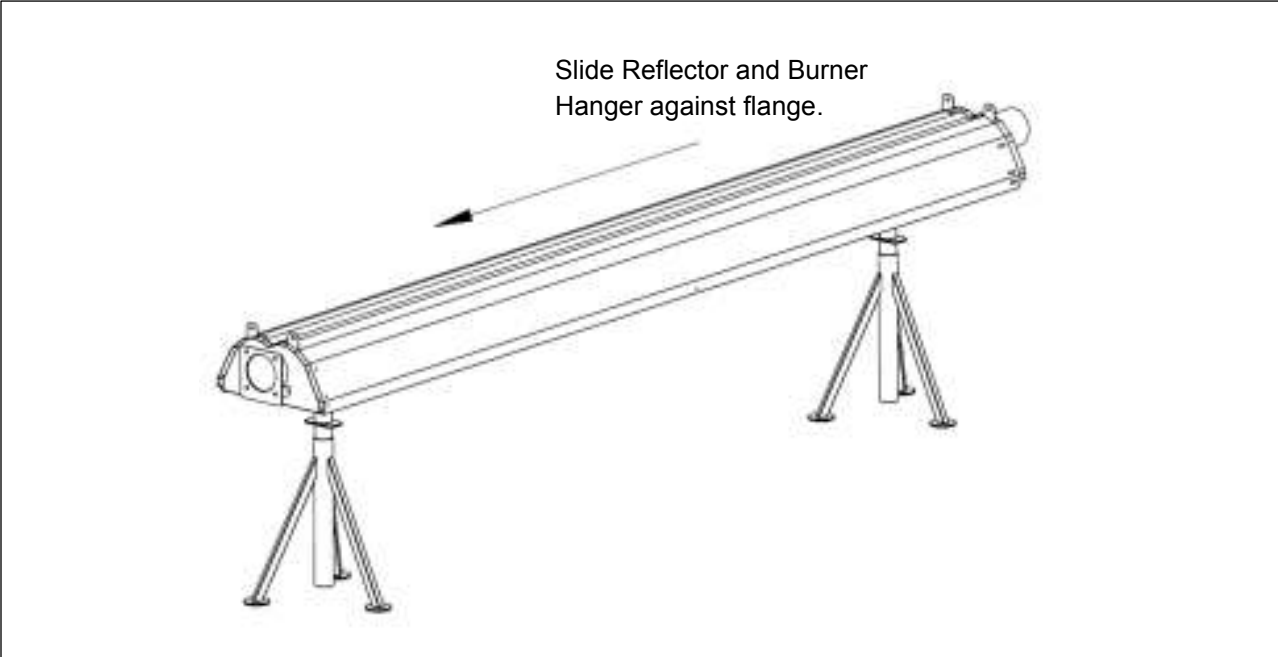

Step 7:

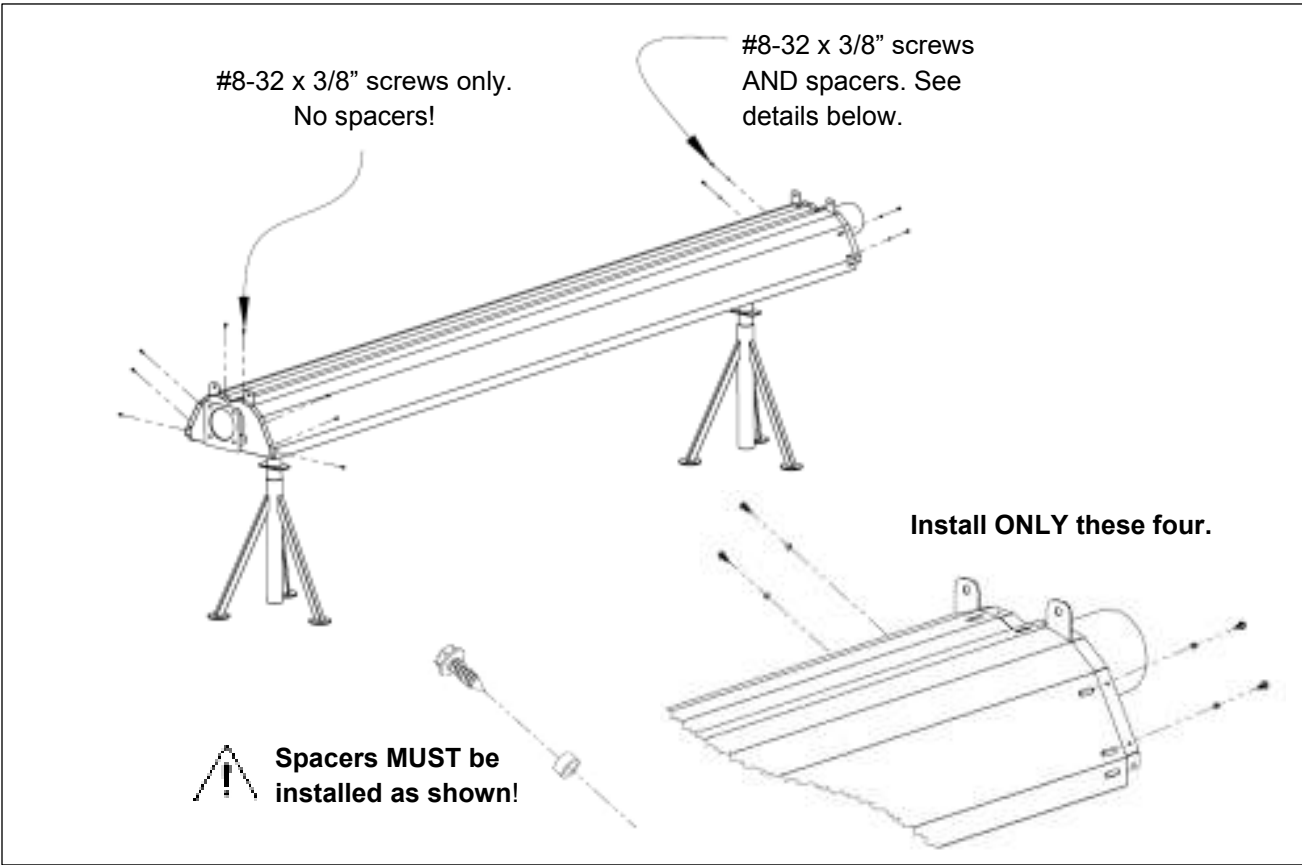

Step 8:

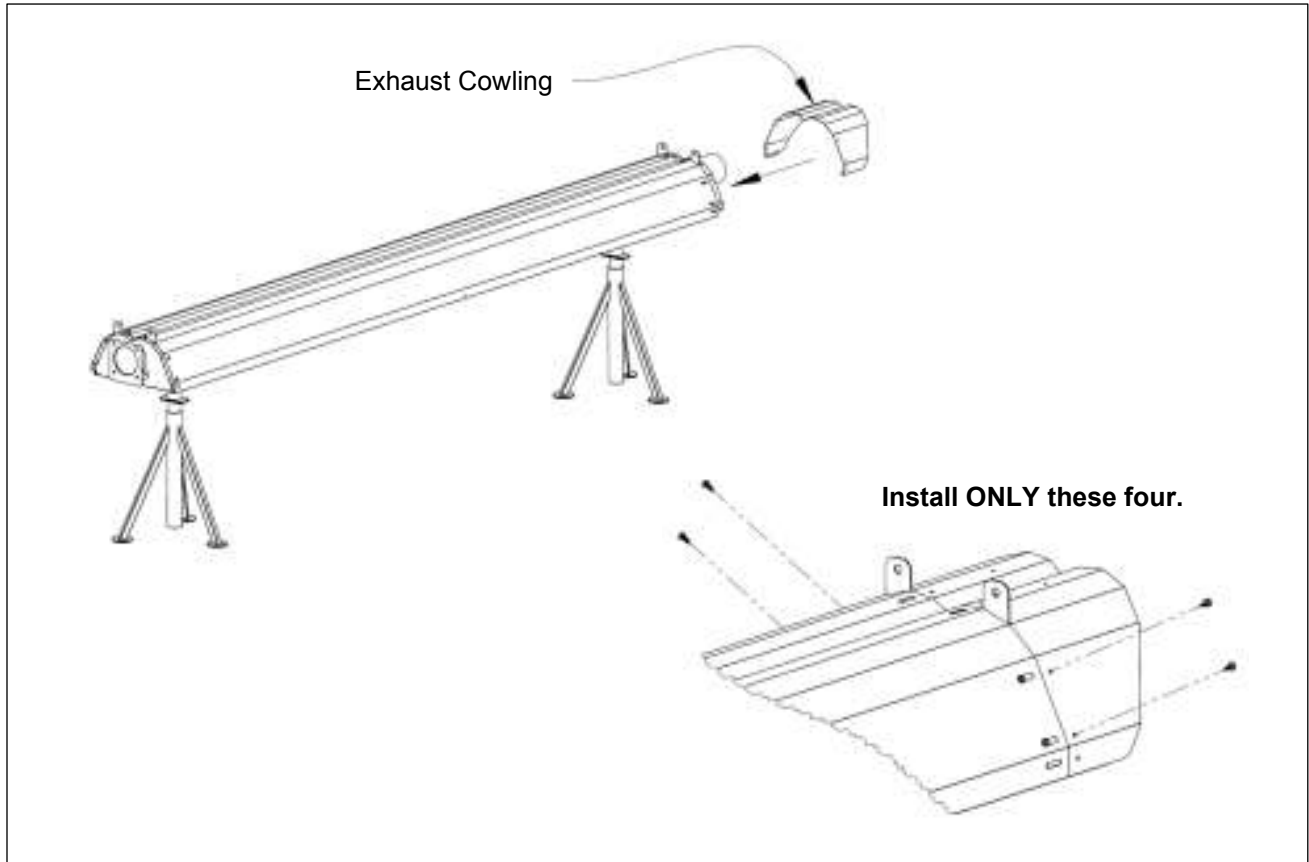

Step 9:

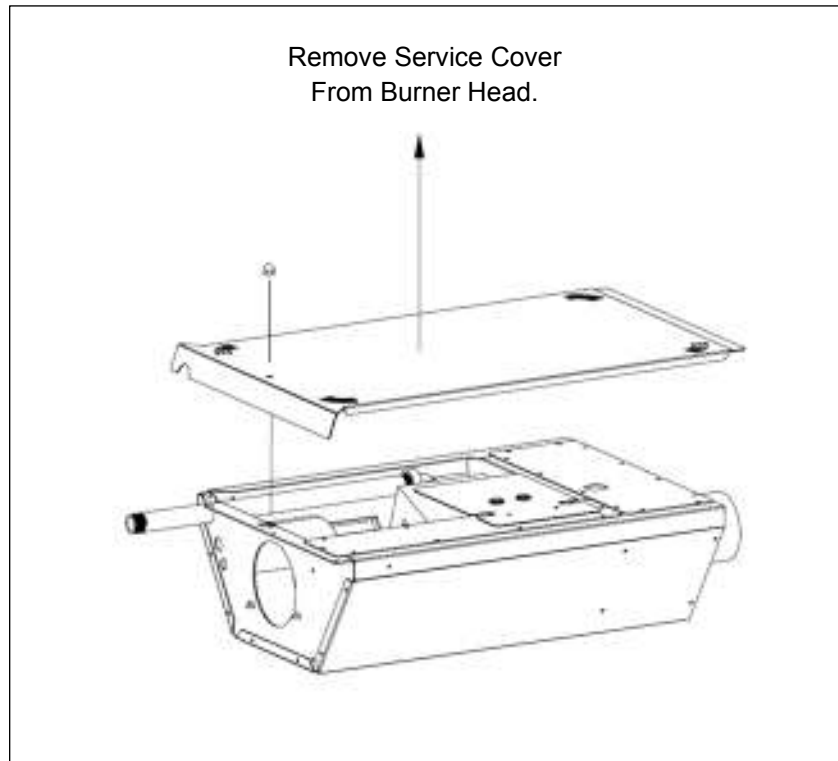

Step 10:

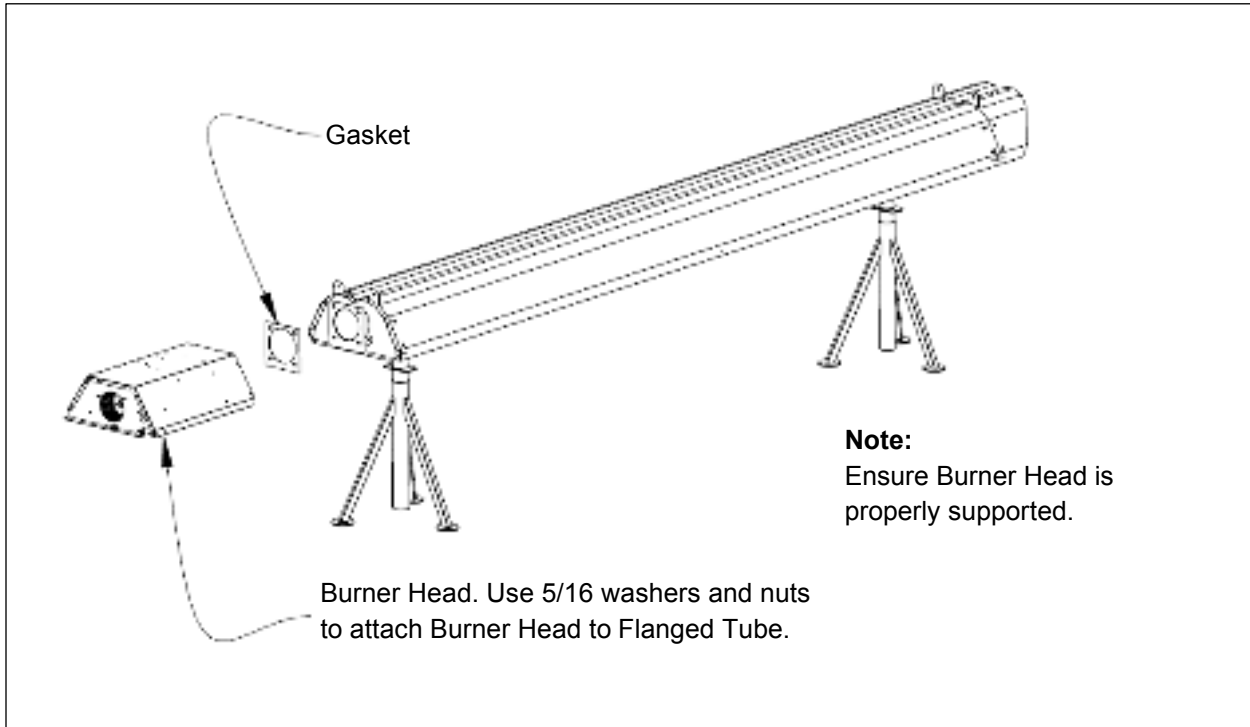

Step 11:

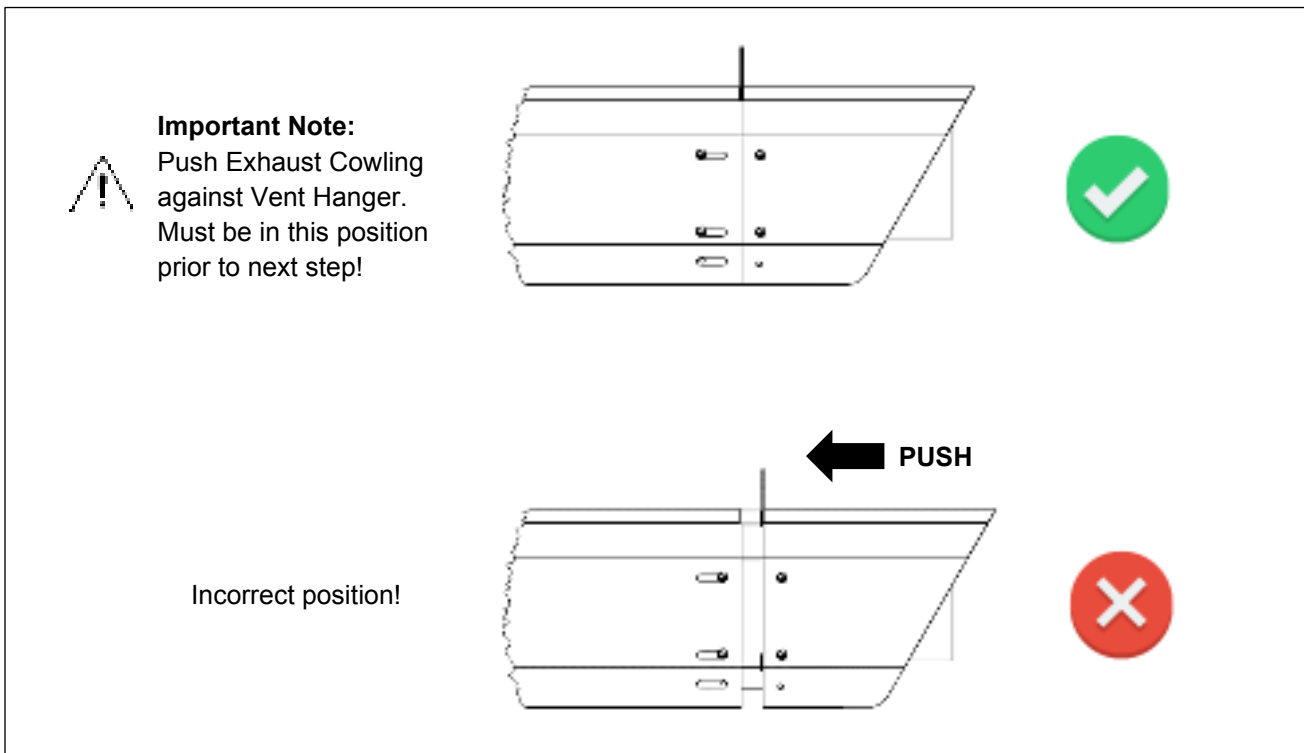

Step 12:

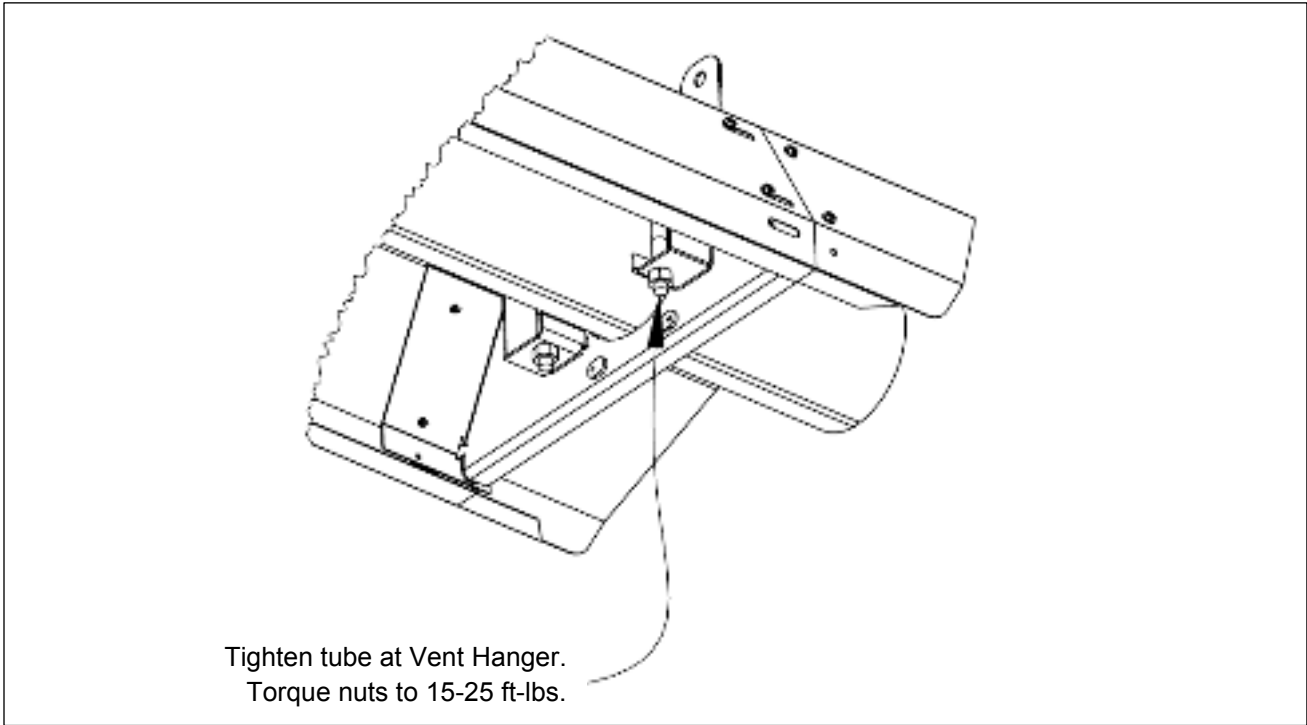

Step 13:

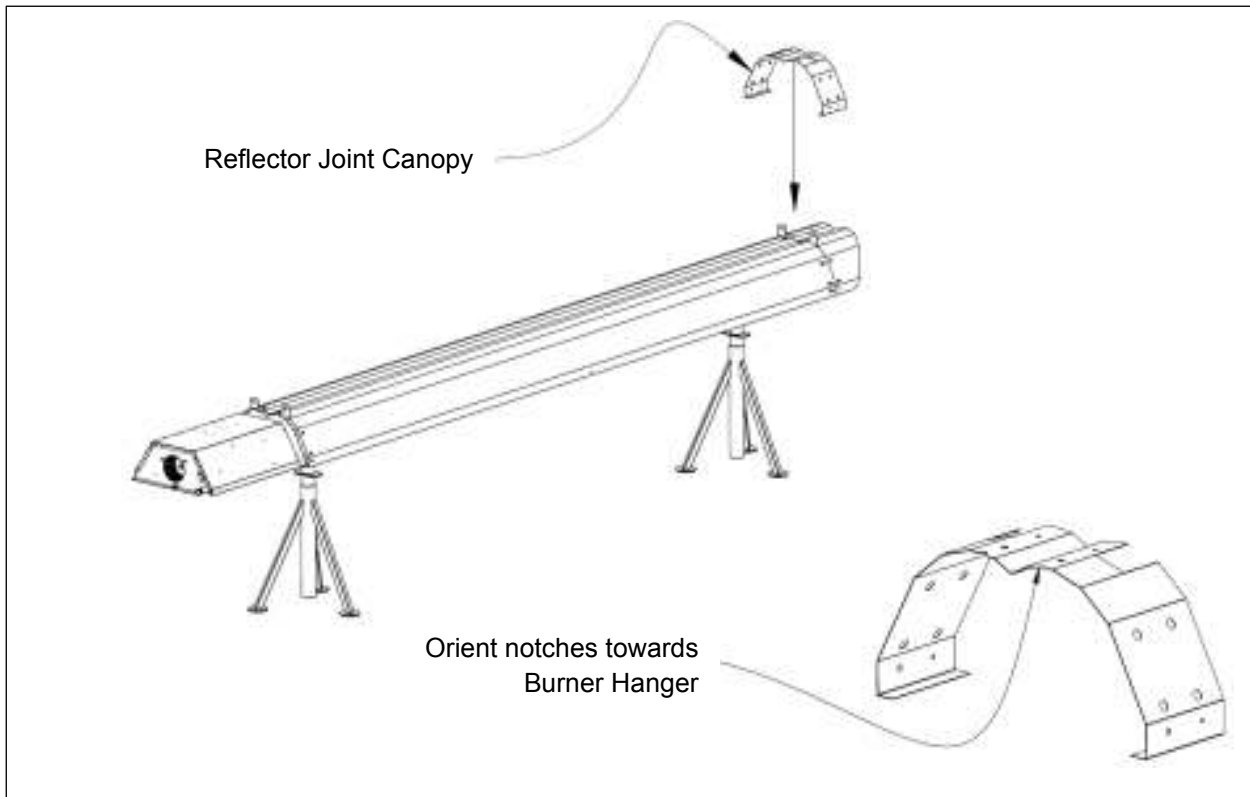

Step 14:

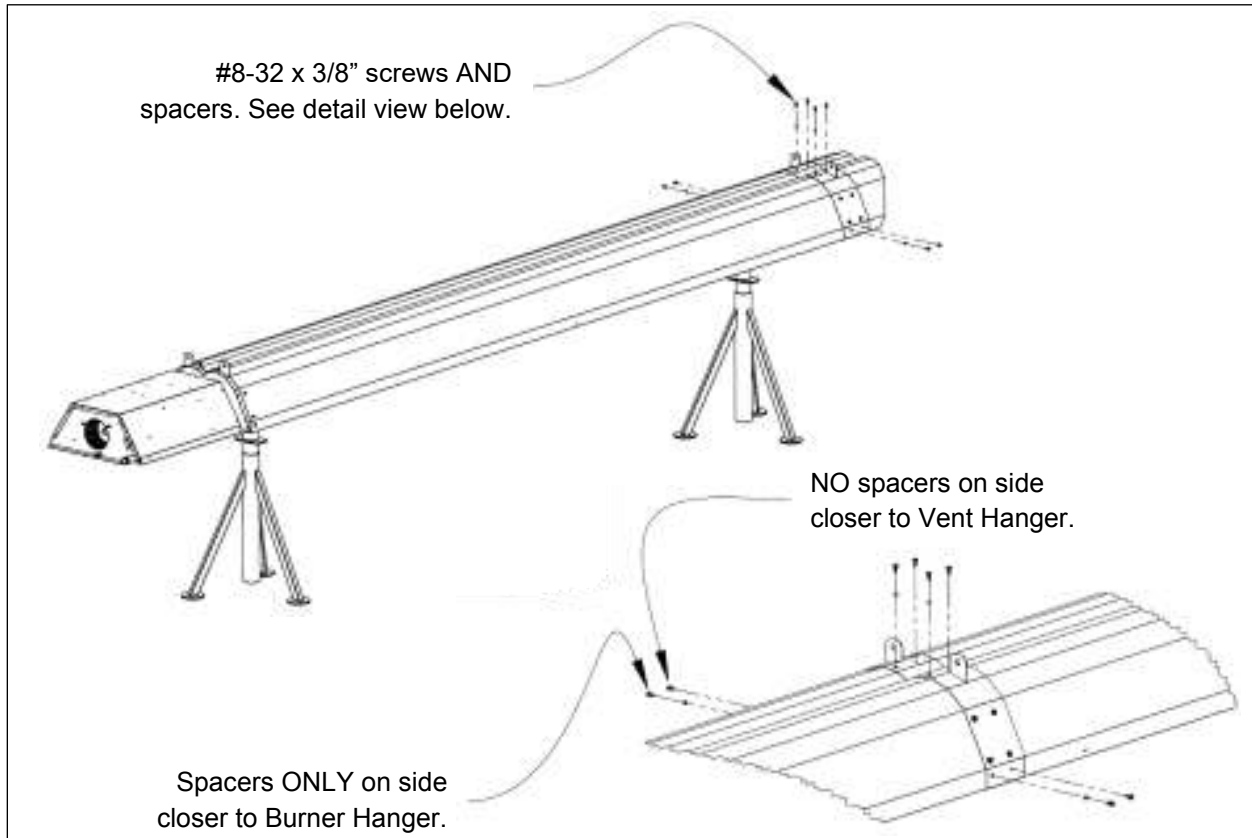

Step 15:

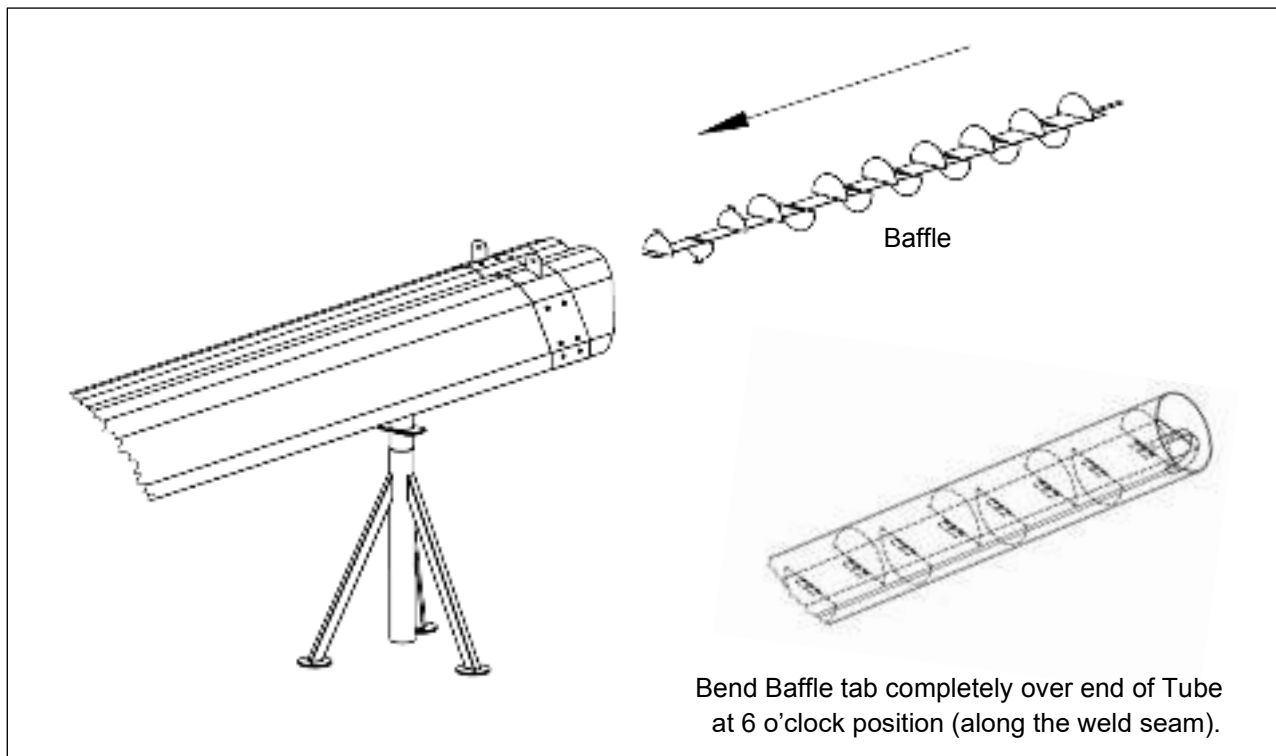

Step 16:

Slide Burner Head Reflector over Burner Head.

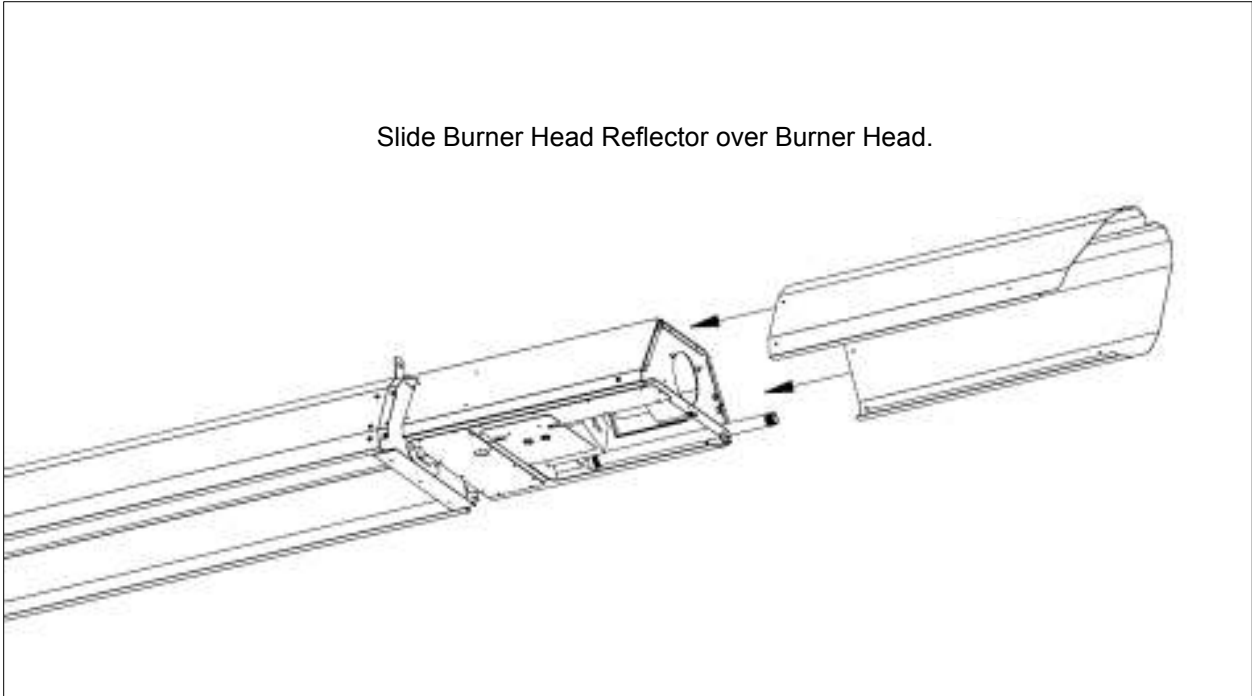

Step 17:

#8-32 x 3/8" screws

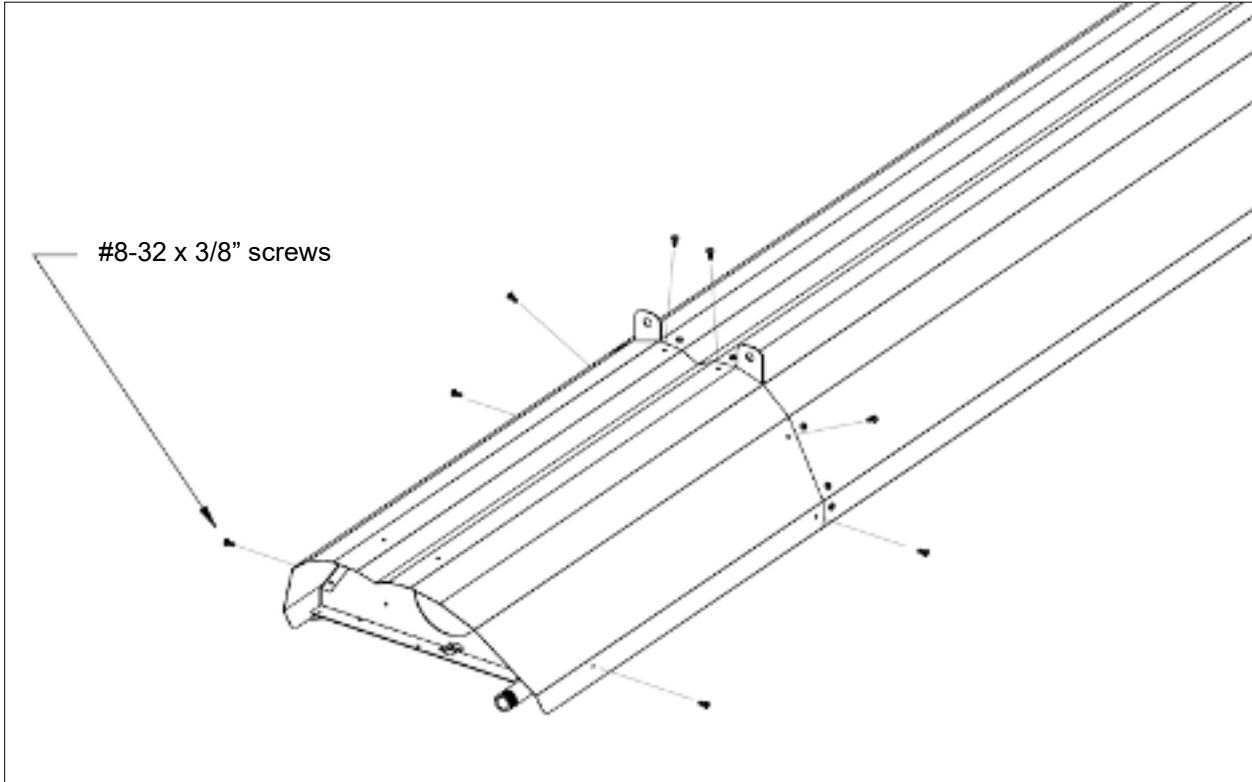

Step 18:

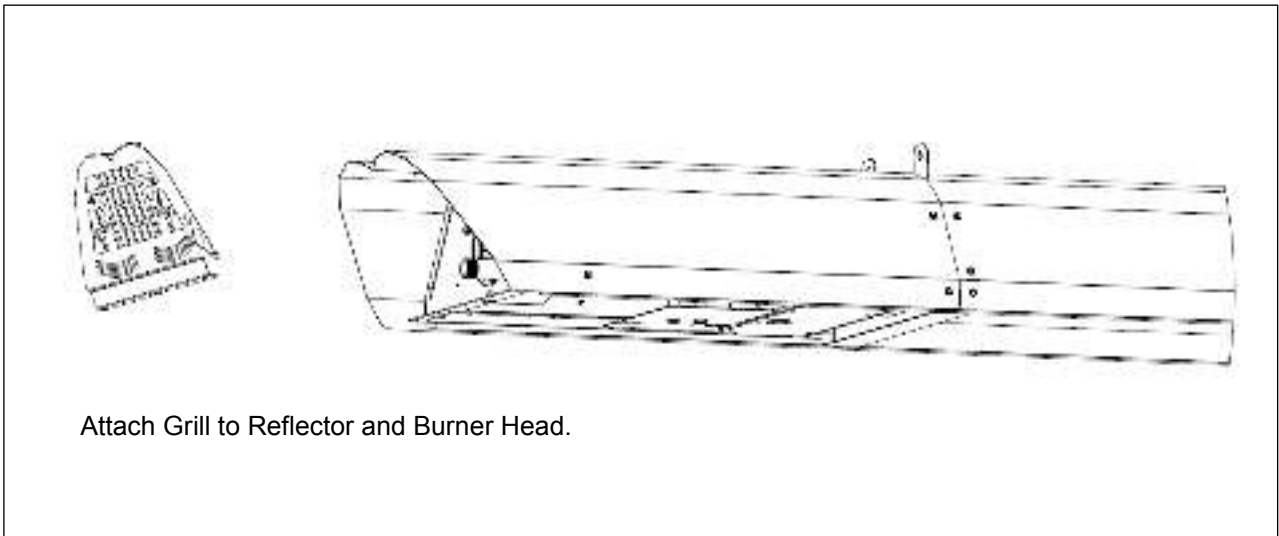

Step 19:

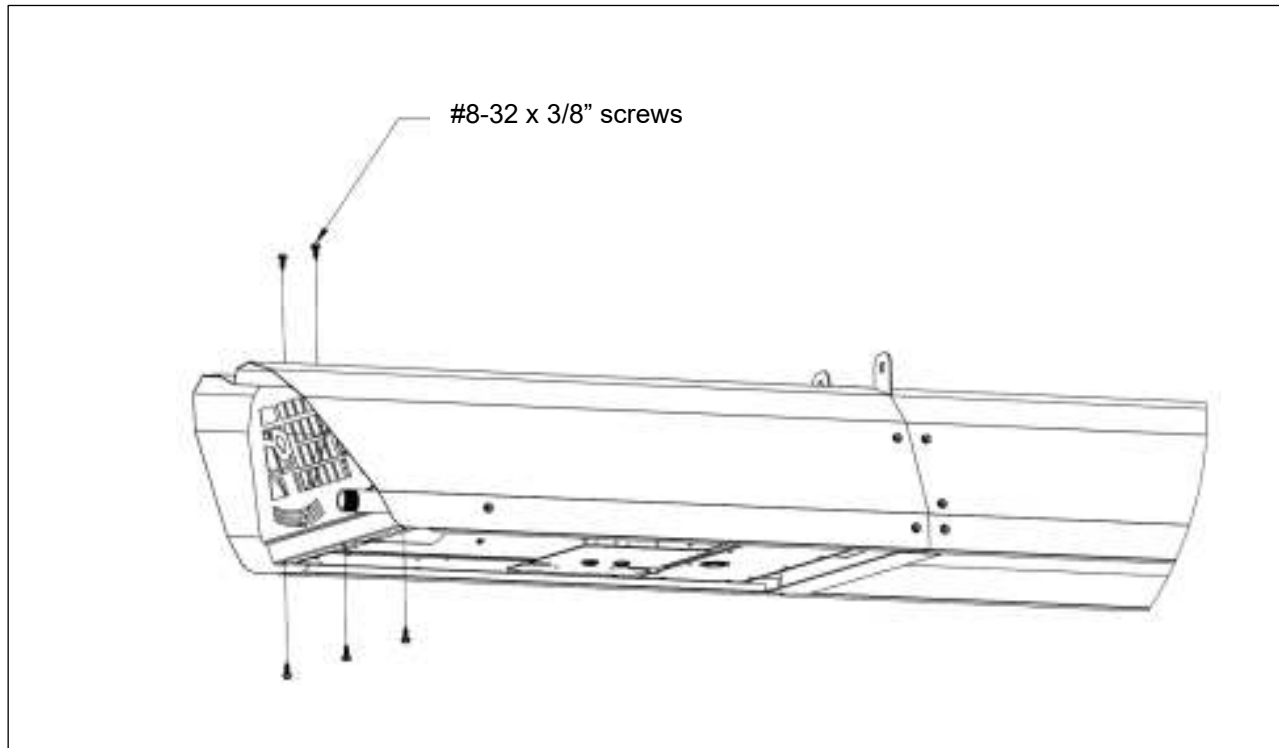

Step 20:

Re-attach Service Cover.

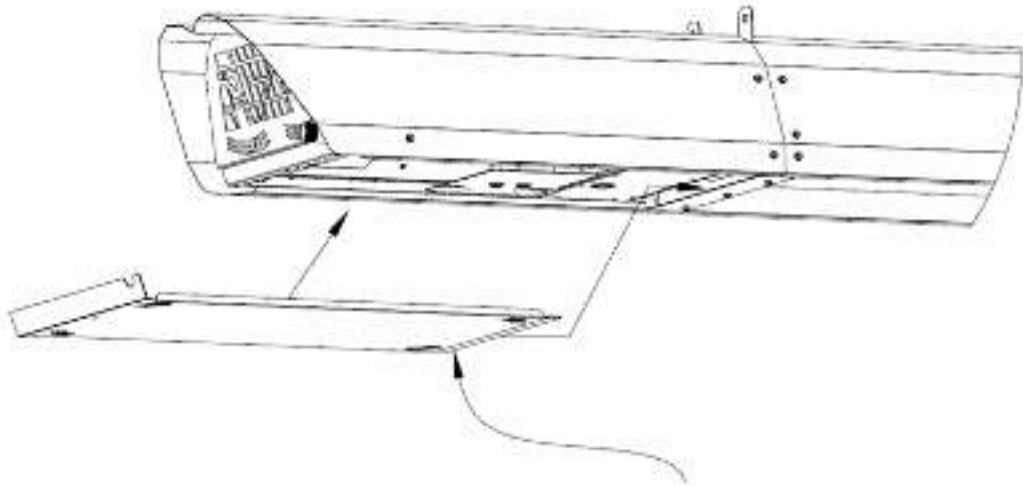

(tuck this edge up and in)

Step 21:

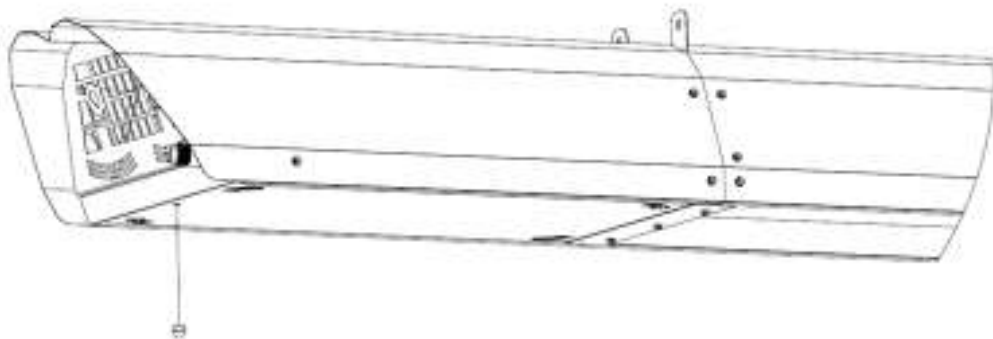

Fasten with acorn nut.

Step 22:

Before installing the Deco Grilles, **bend all the tabs** along one *long* side and both *short* sides of the Grille for easier fitment.

*Gloves recommended!

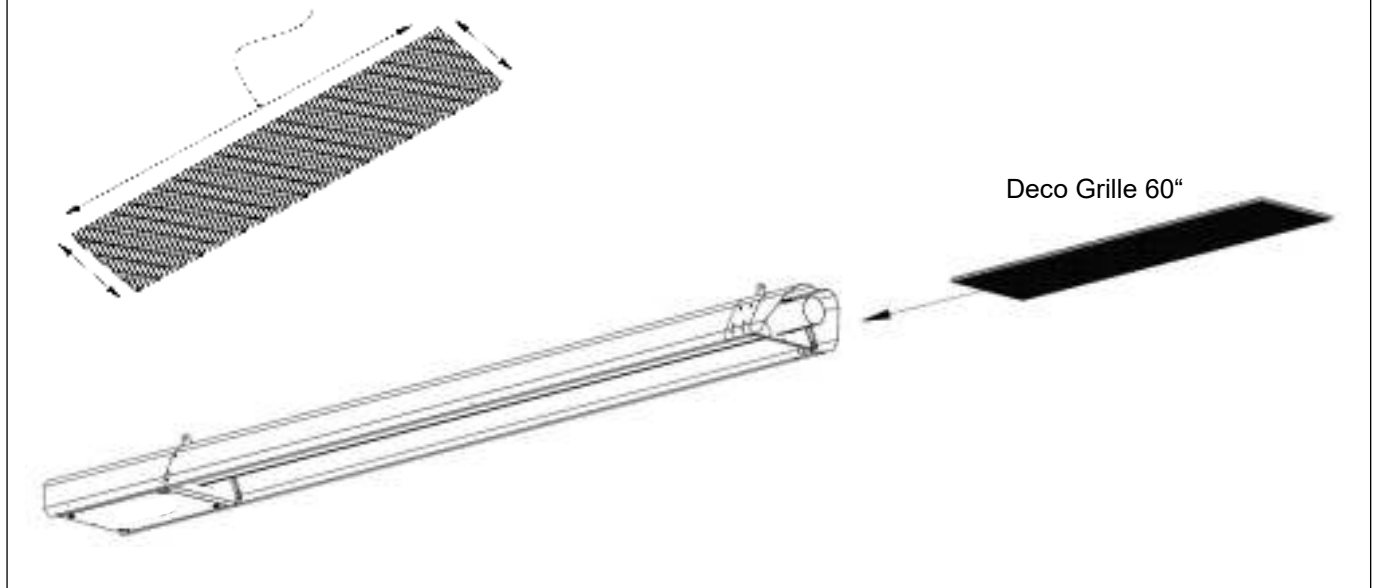

Step 23:

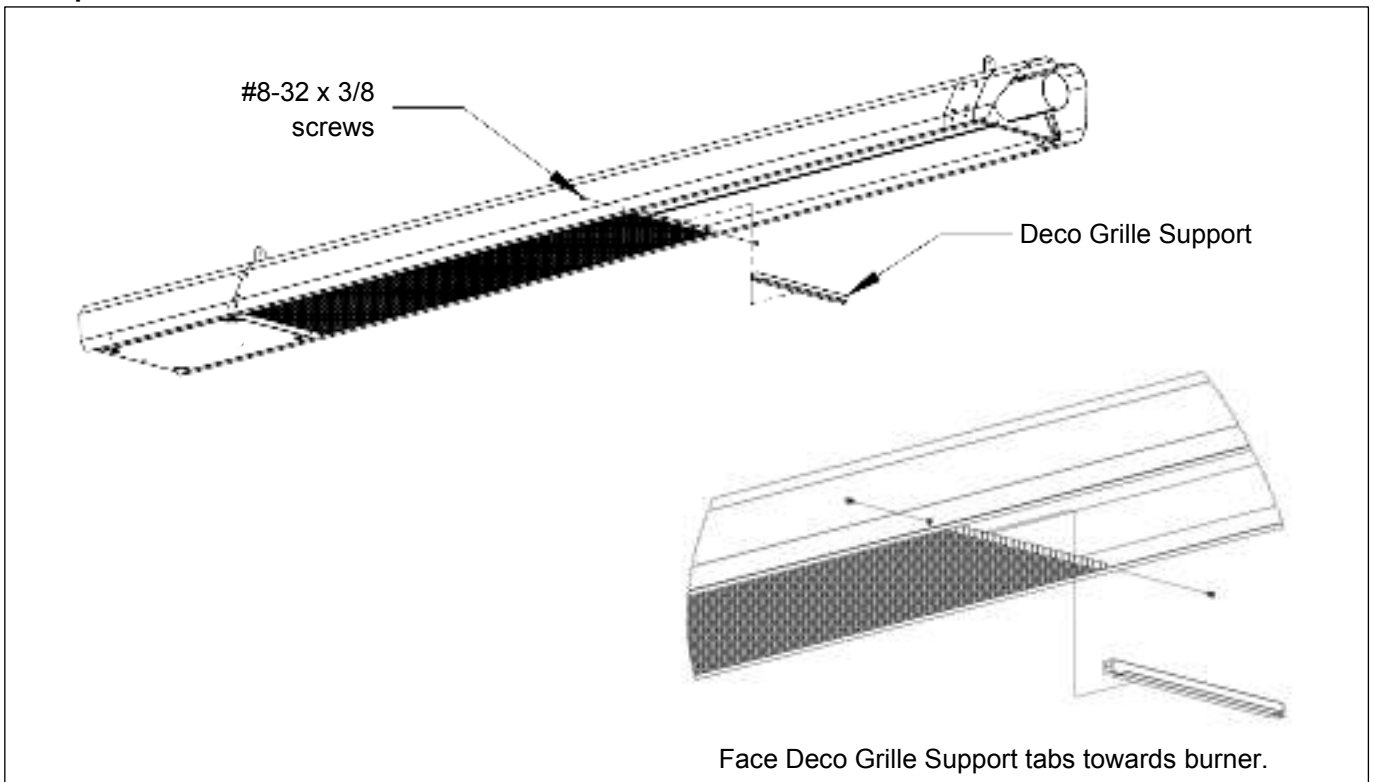

Step 24:

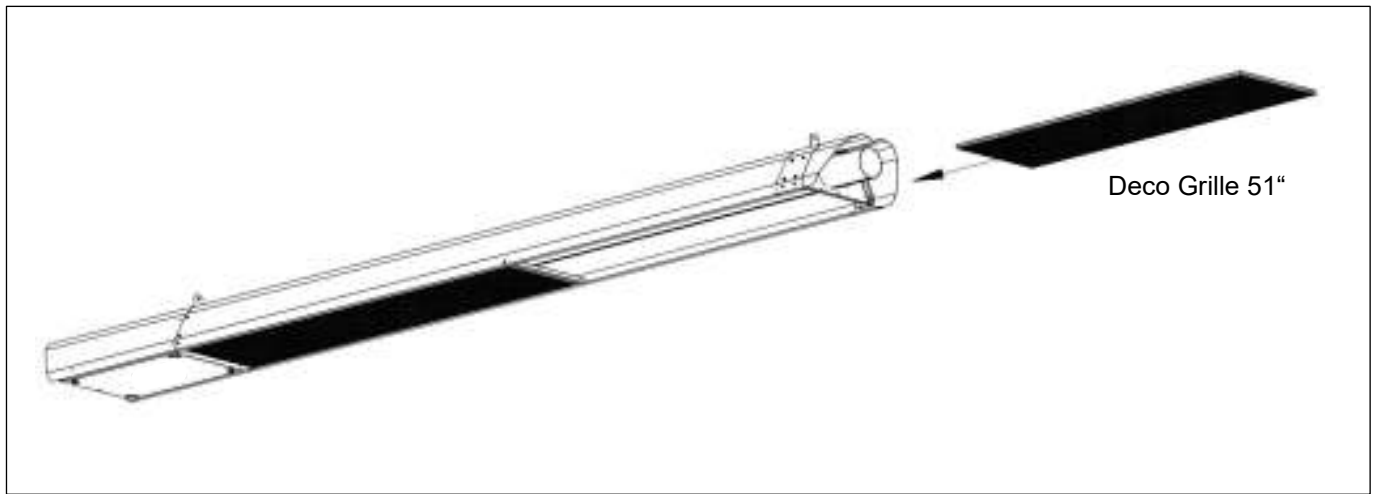

Step 25:

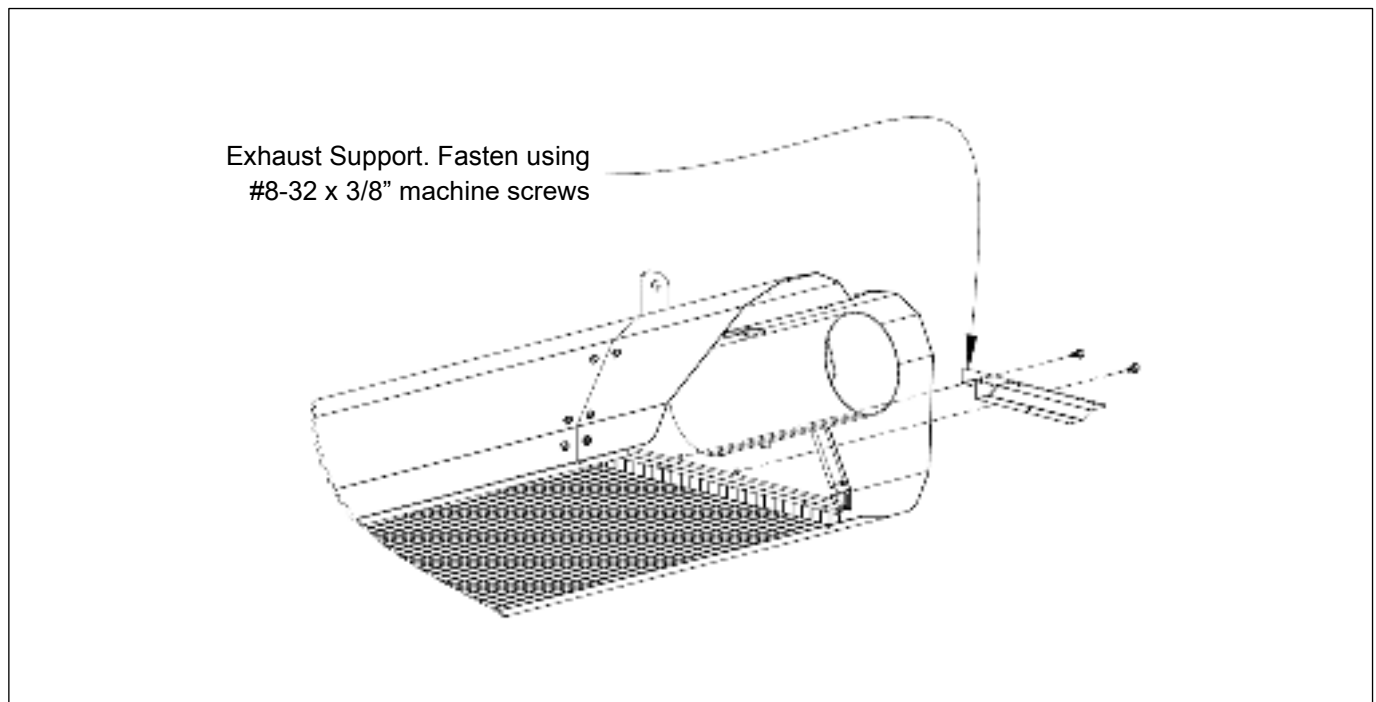

Step 26:

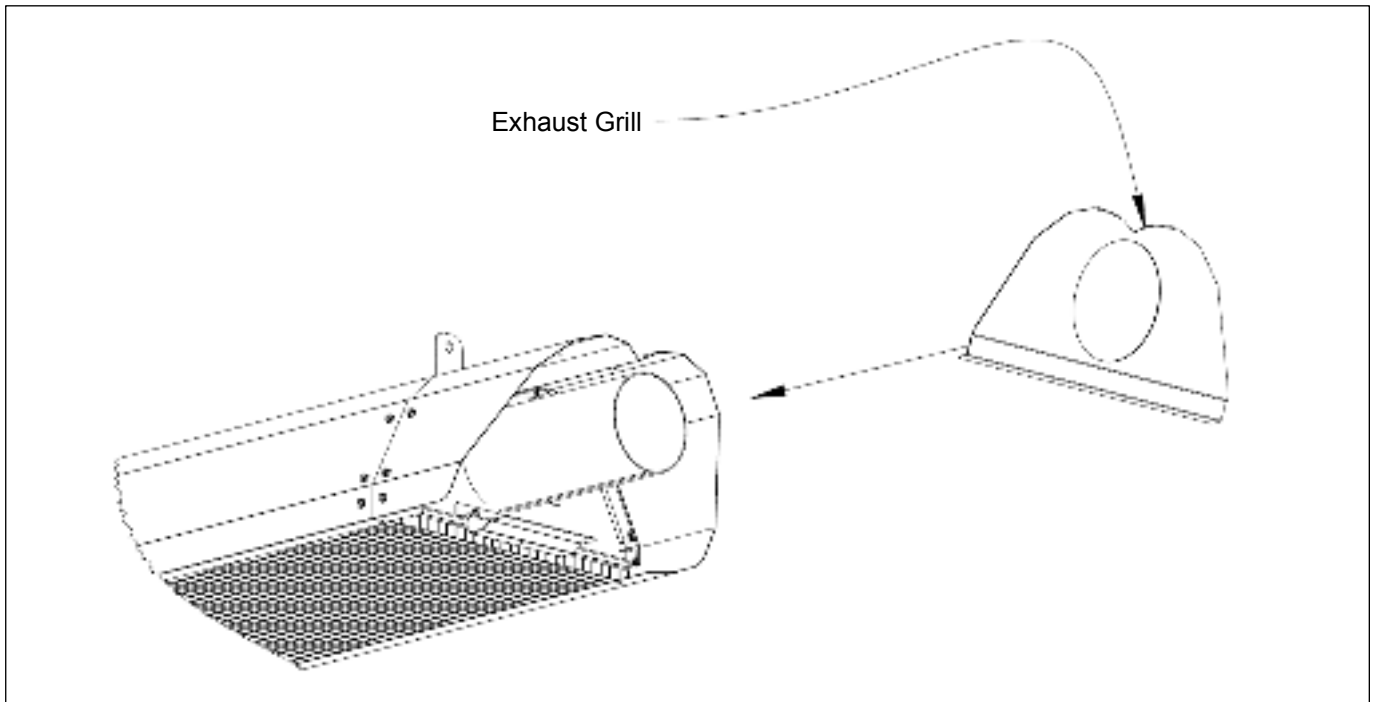

Step 27:

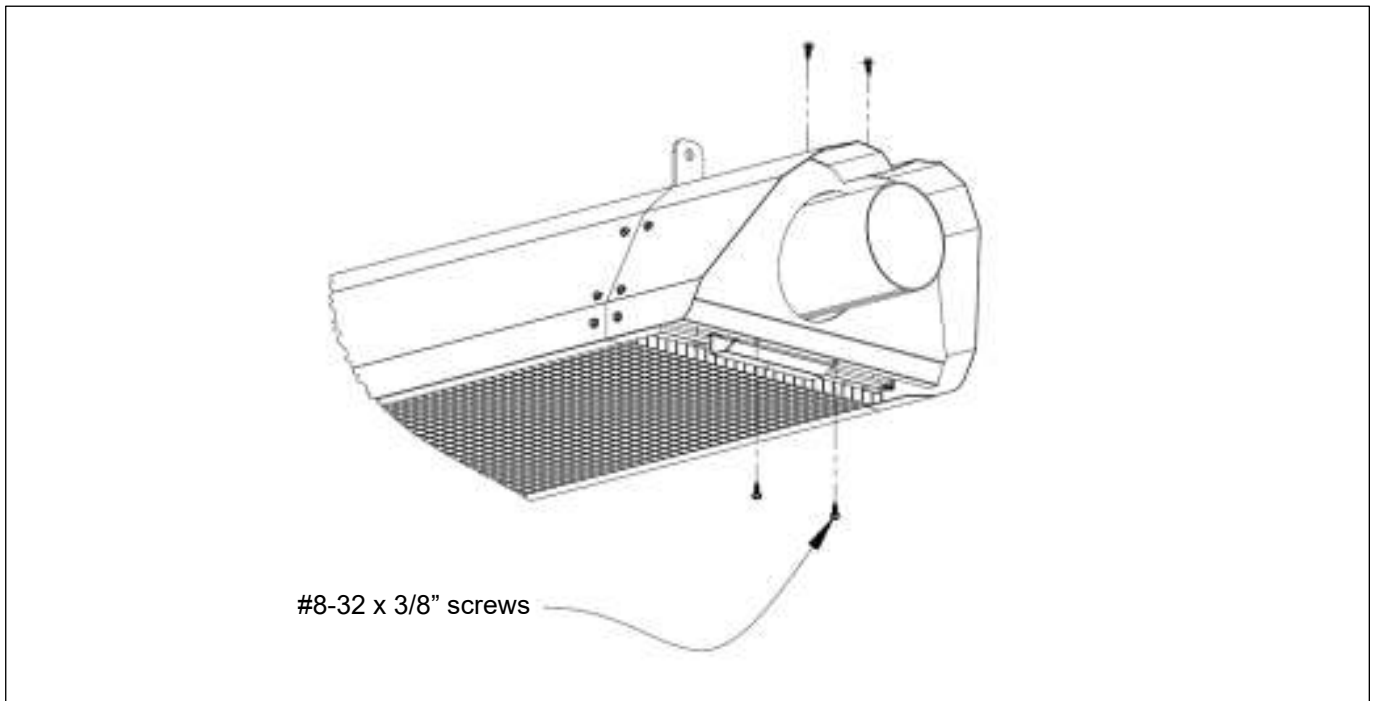

Step 28:

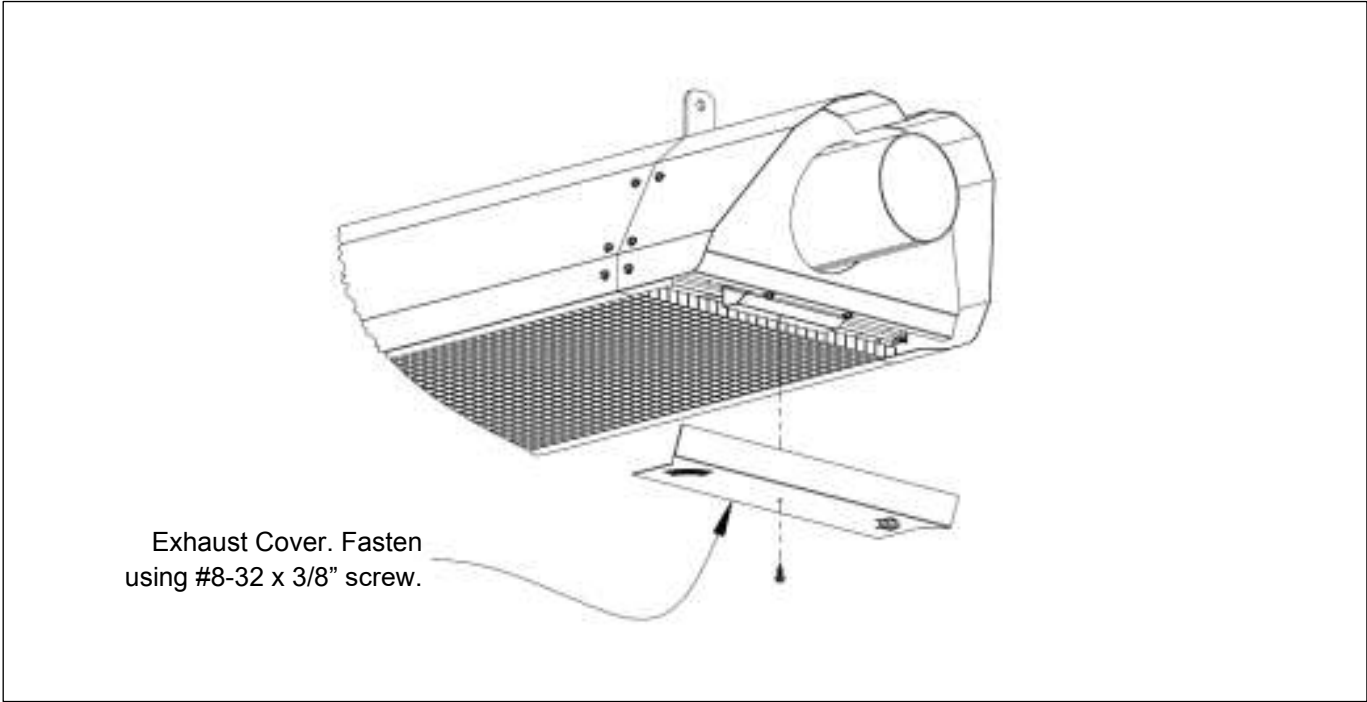

Step 29:

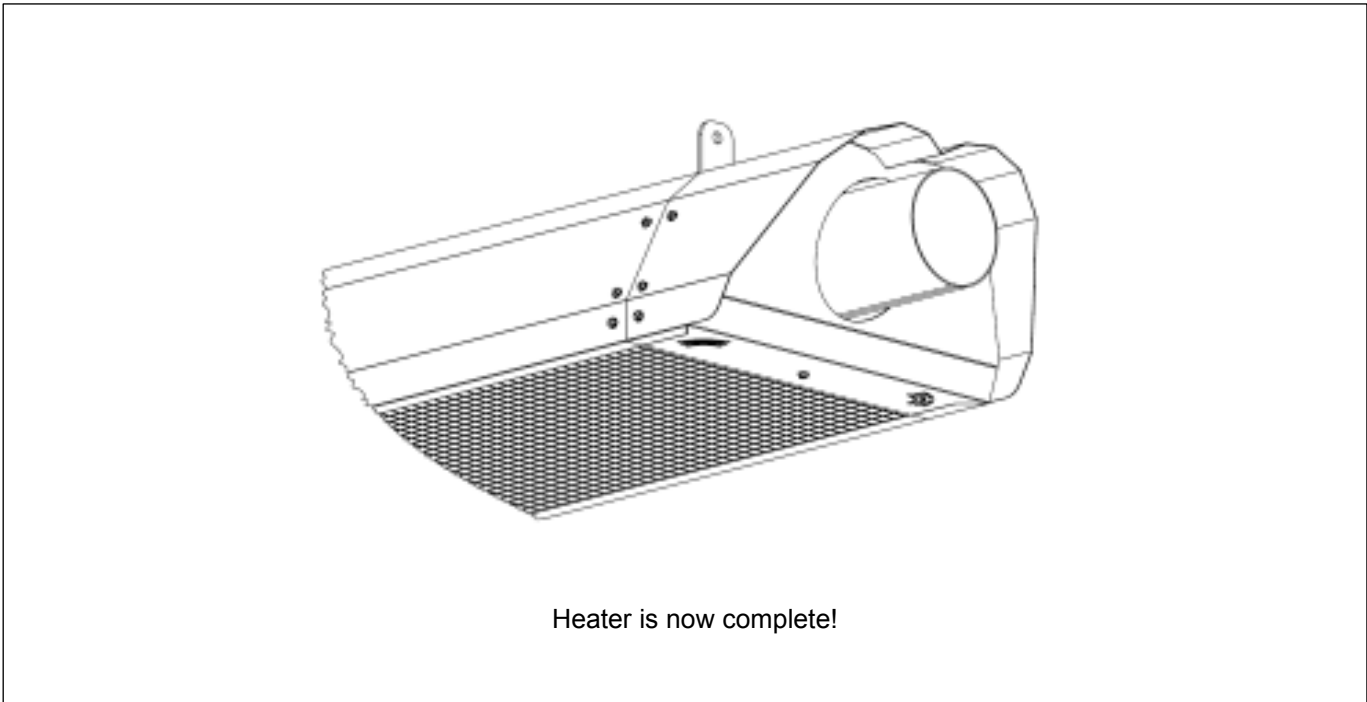

Installation Sequence ETSV 80

Generally, there is no unique sequence for installation of the burner or heat exchanger. A review of the job site will usually indicate a logical installation order. However, time and expense can be saved if installation is begun at the most critical dimension, watching for interference from overhead beams etc.

It is **RECOMMENDED** to follow the assembly sequence shown in the following pages for free hanging installation.

Step 1:

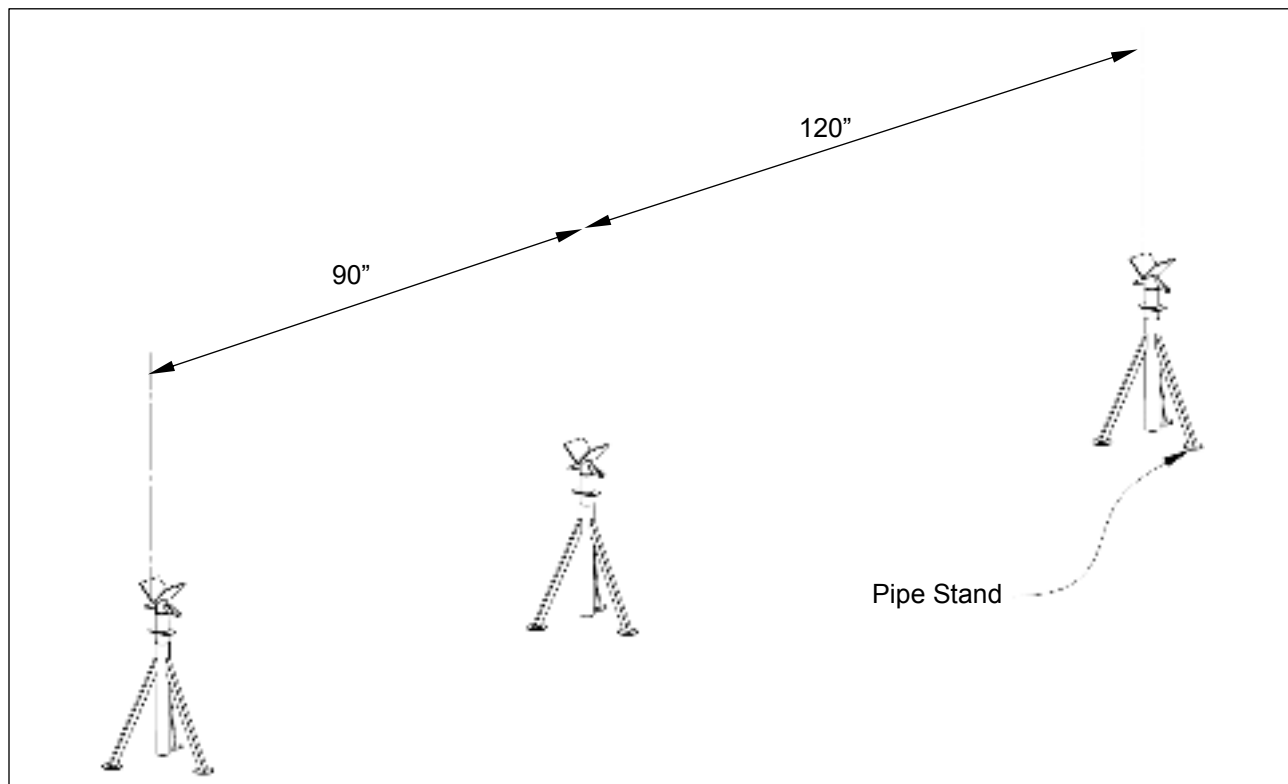

Step 2:

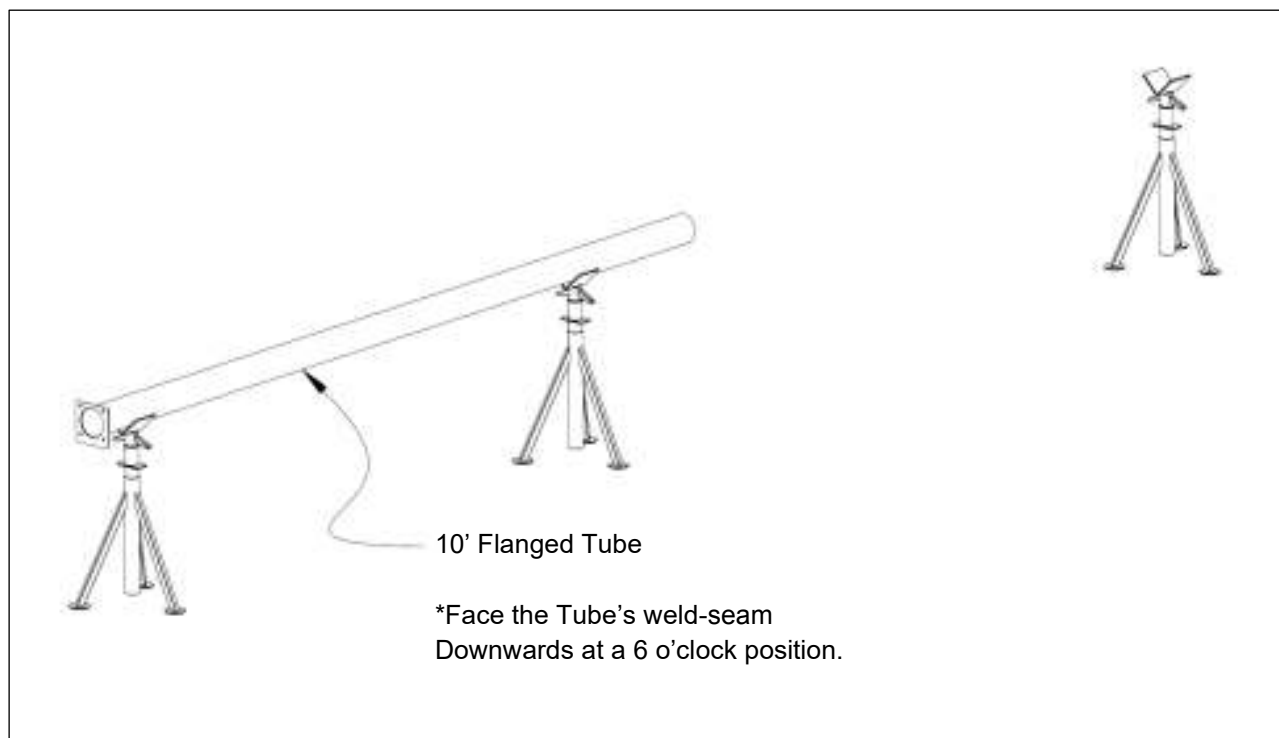

Step 3:

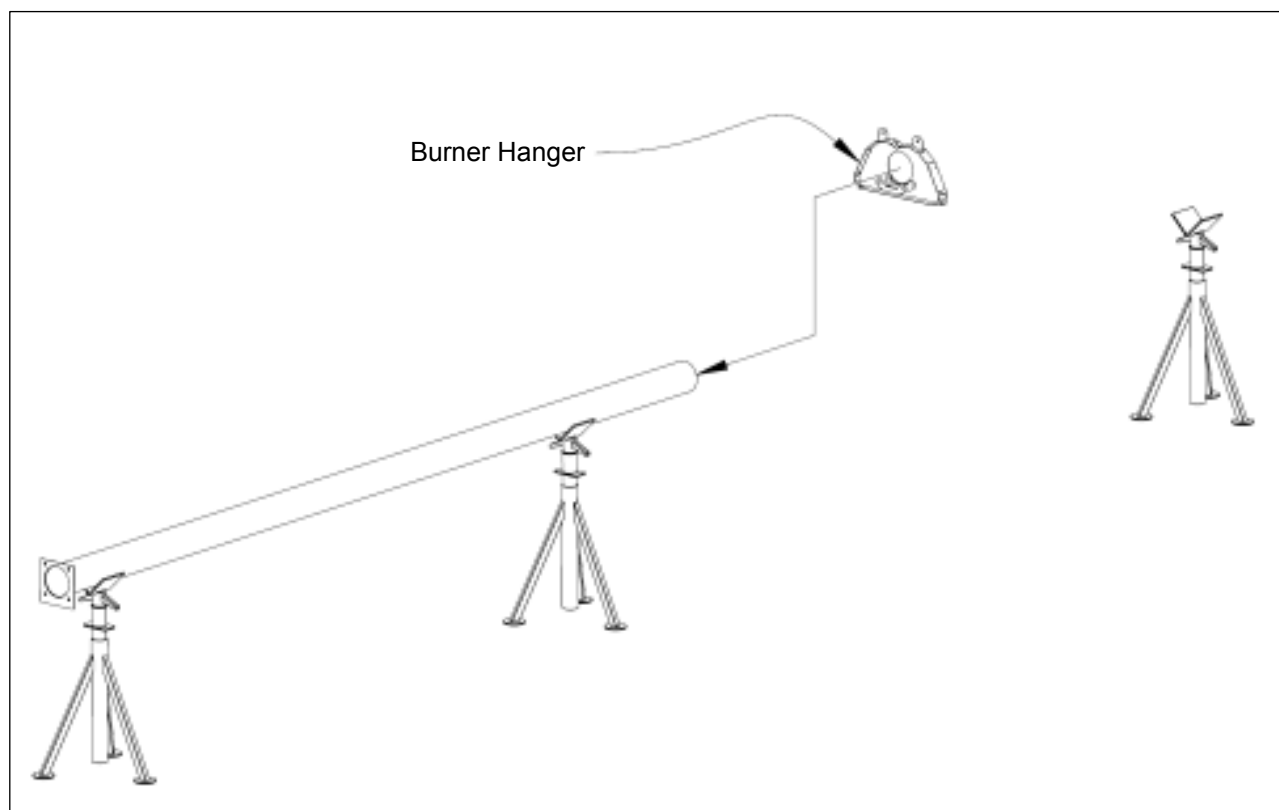

Step 4:

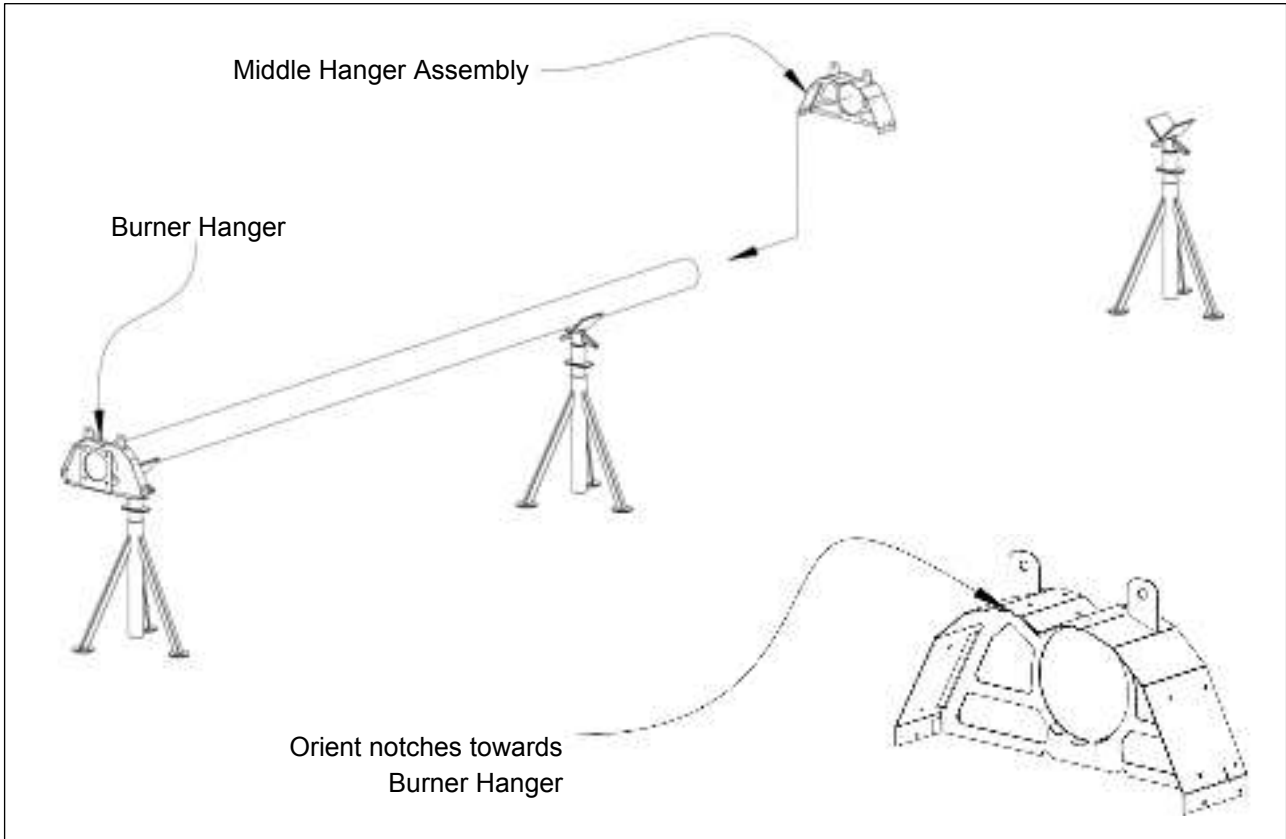

Step 5:

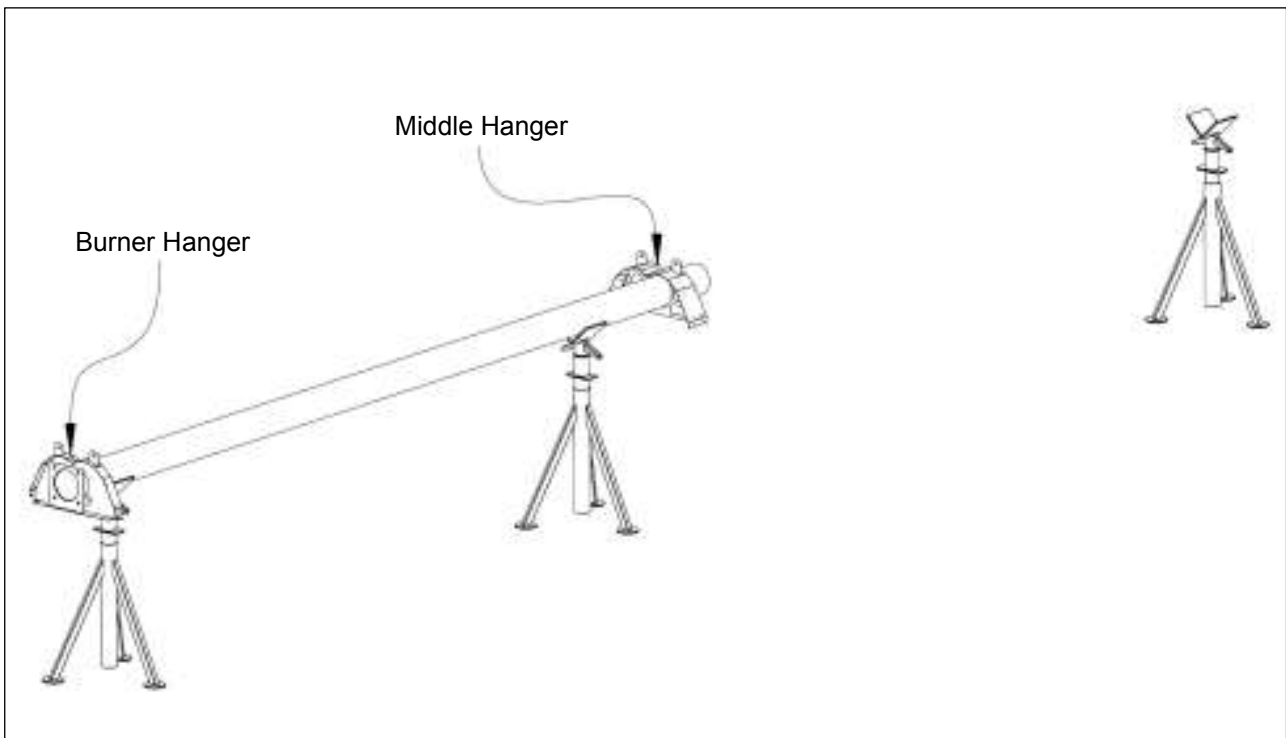

Step 6:

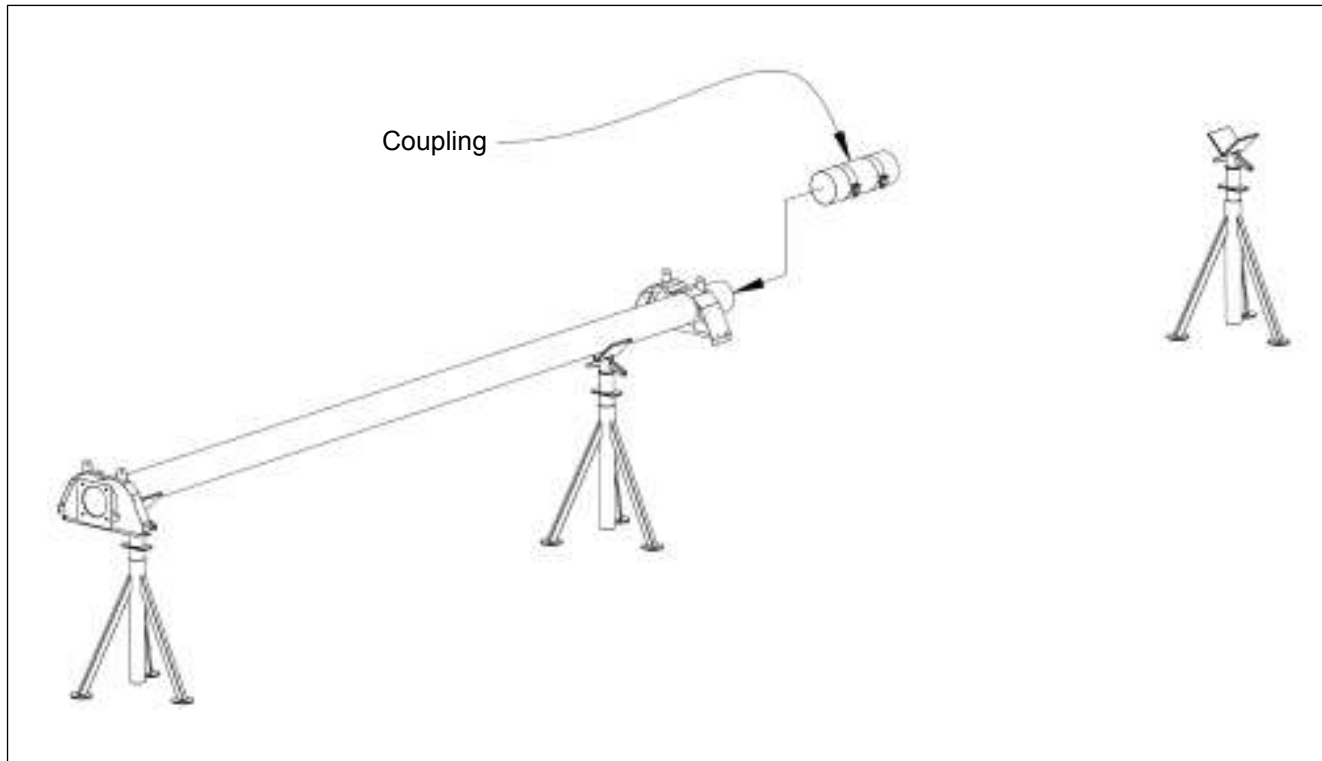

Step 7:

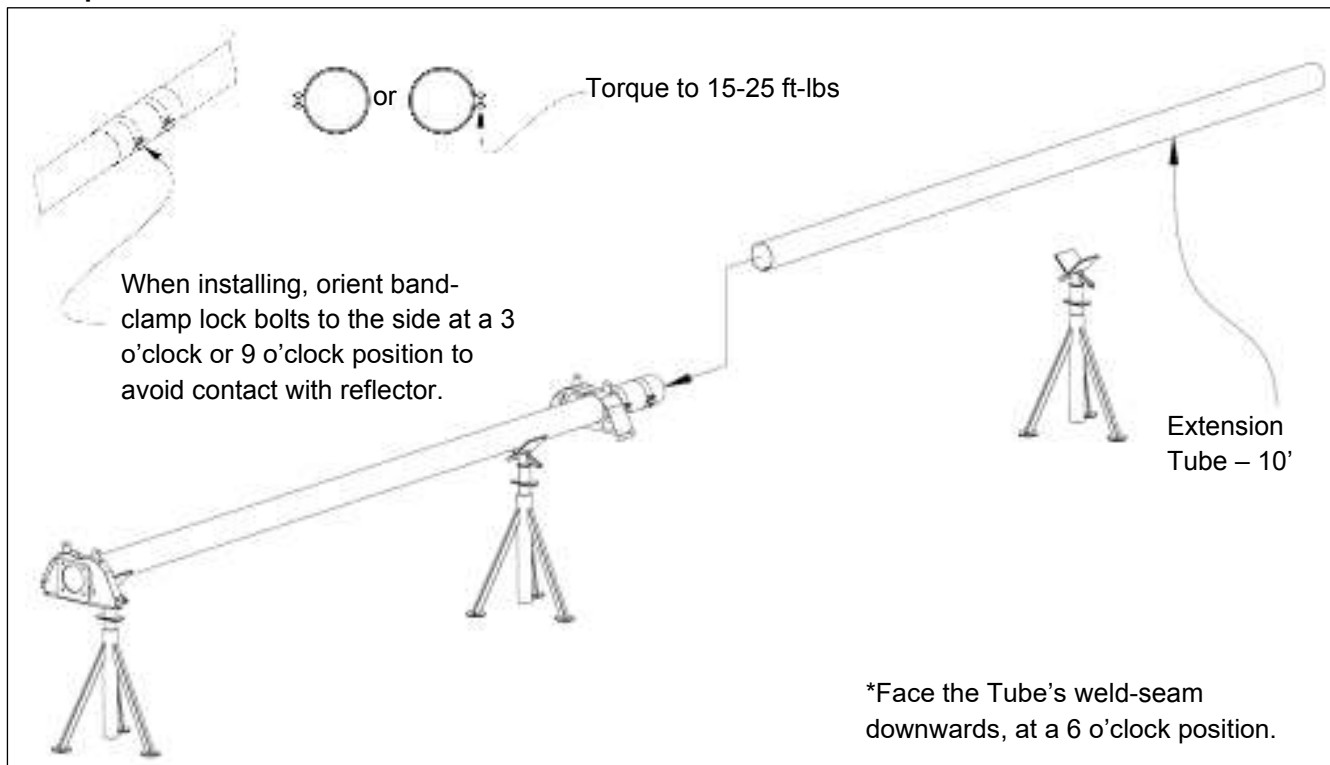

Step 8:

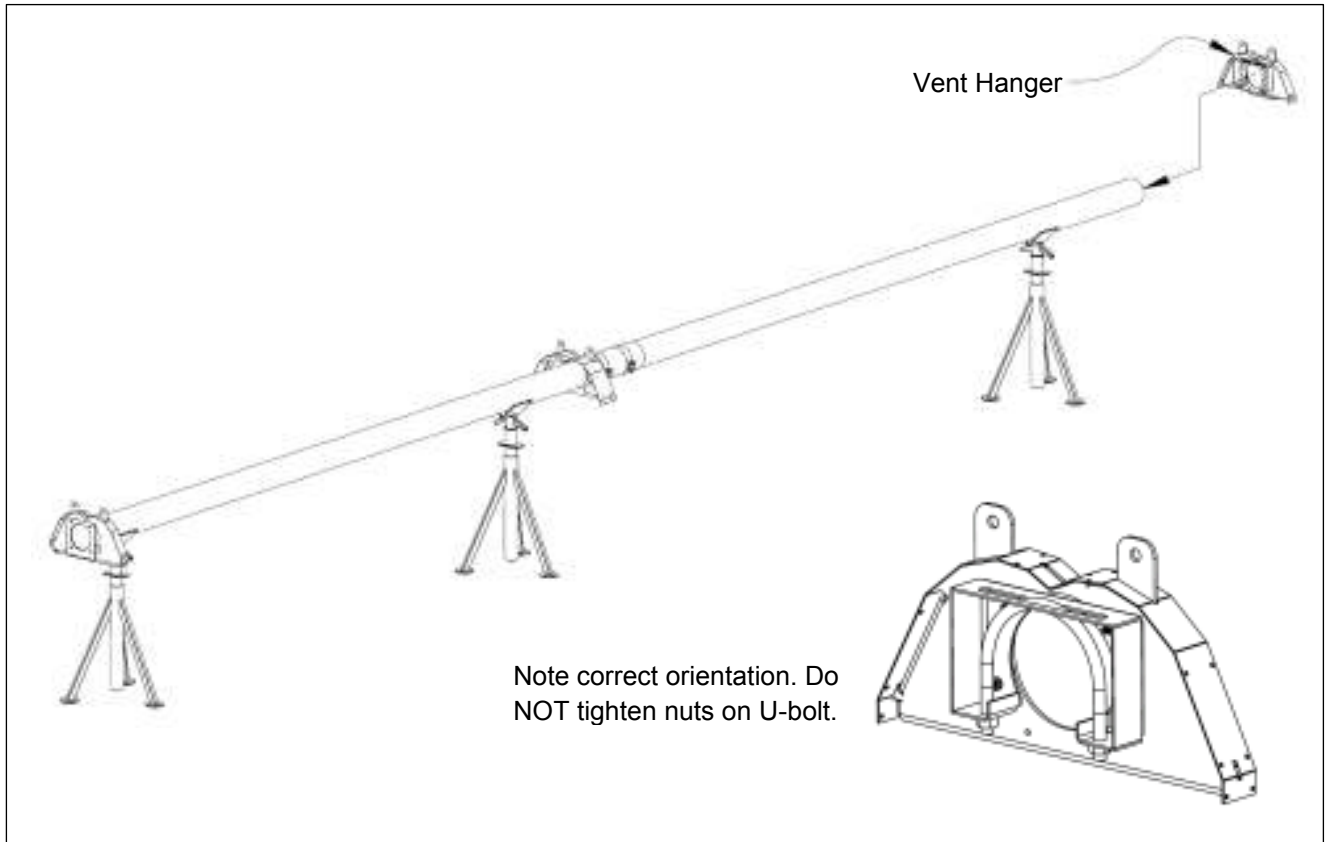

Step 9:

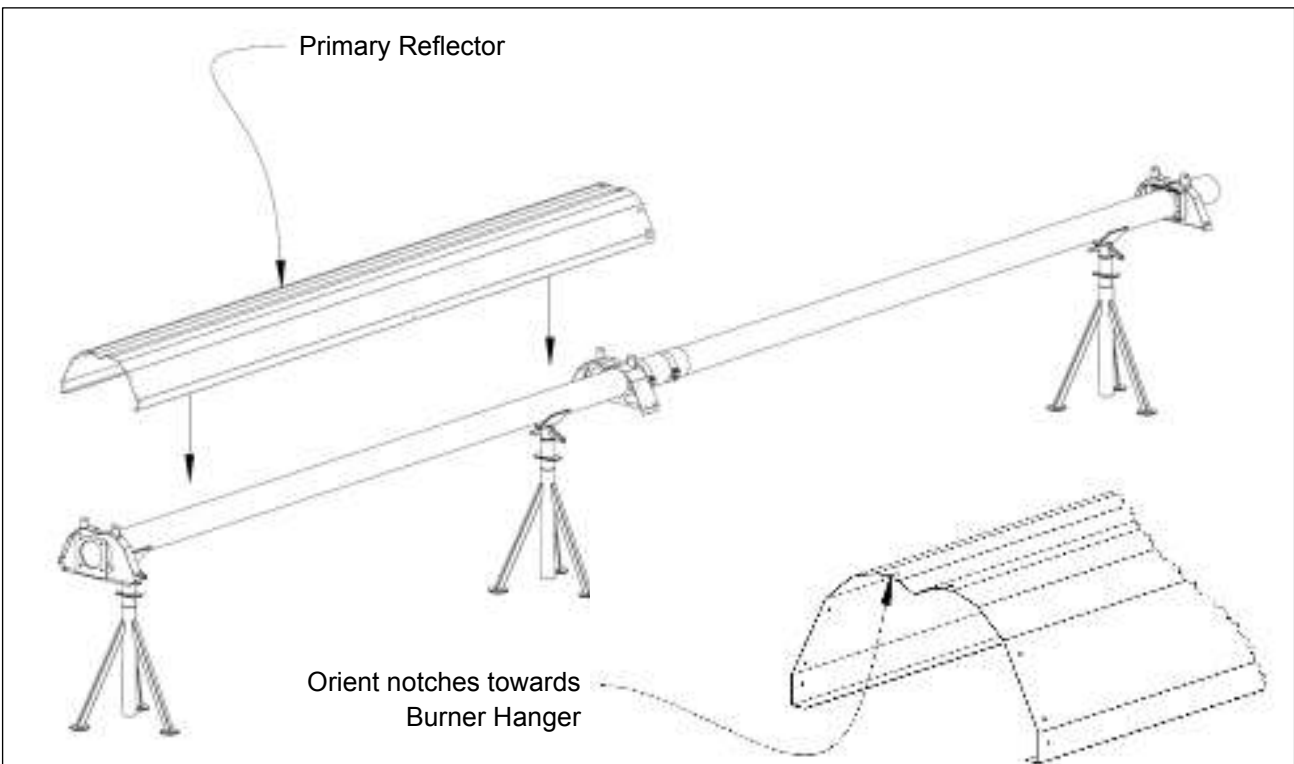

Step 10:

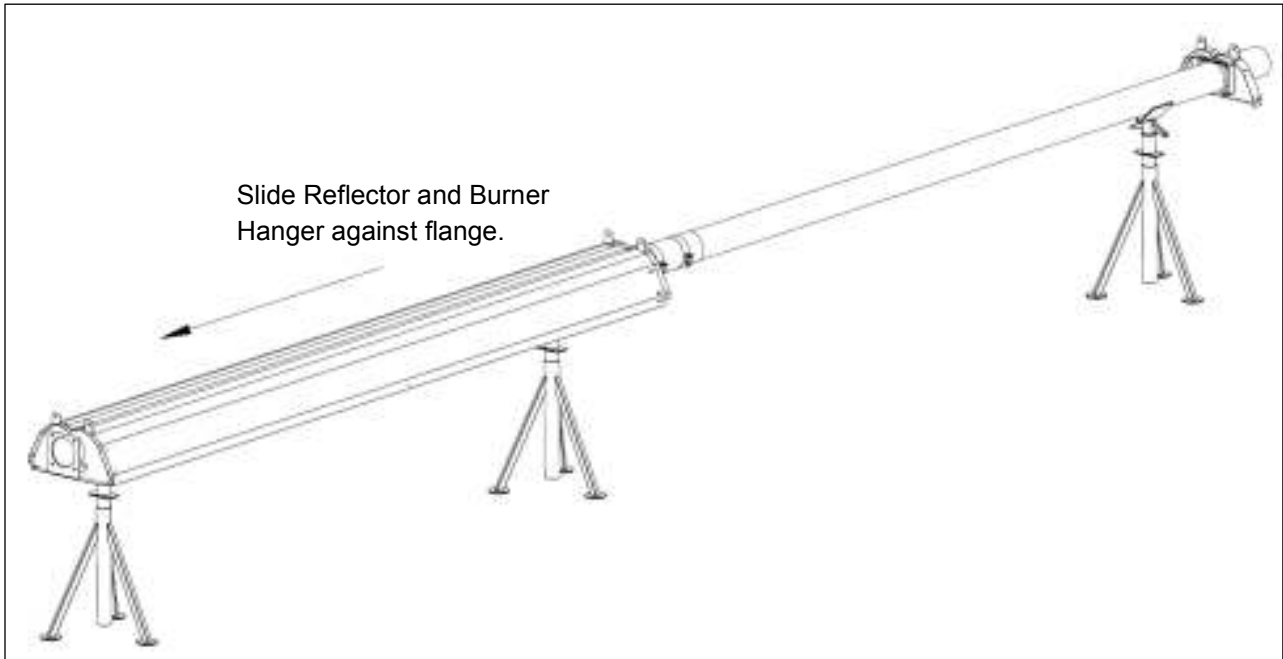

Step 11:

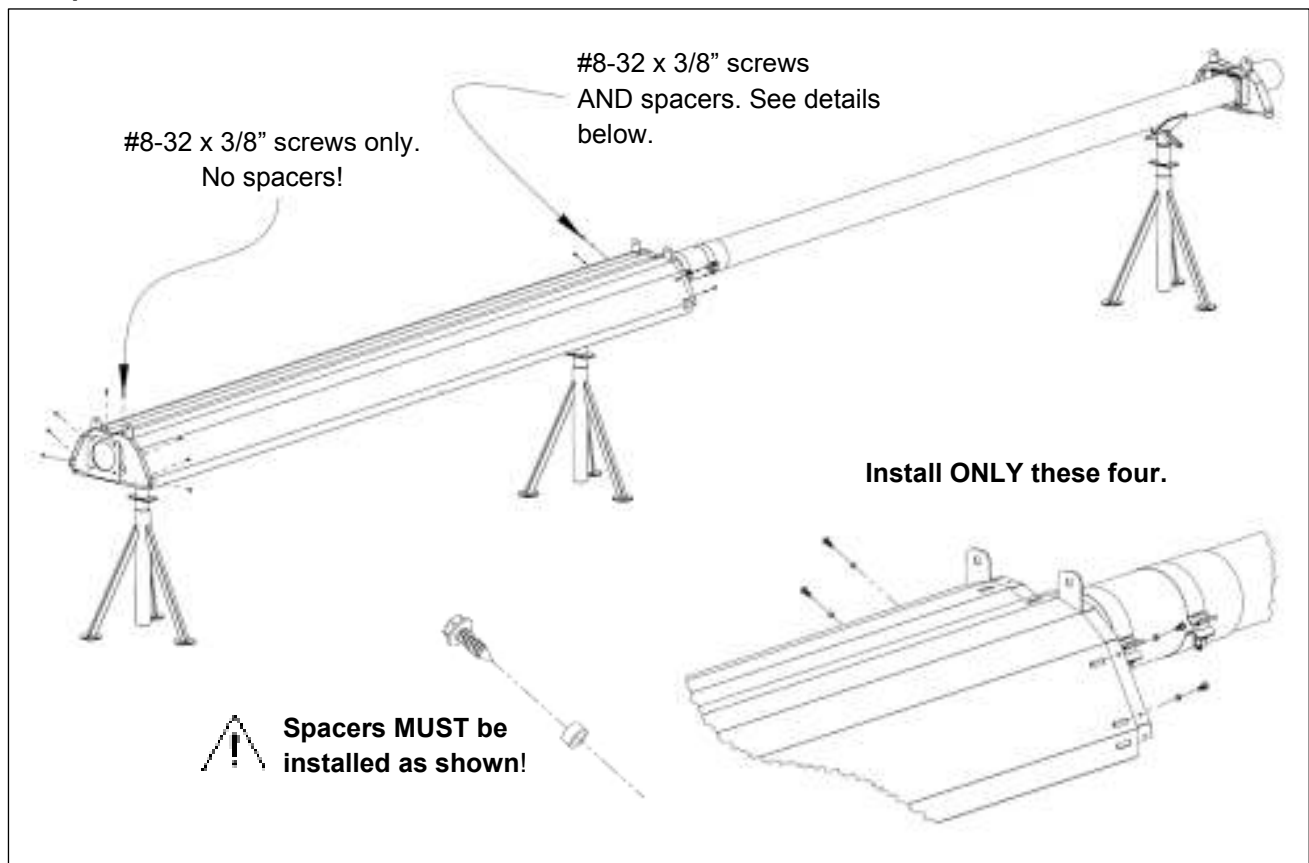

Step 12:

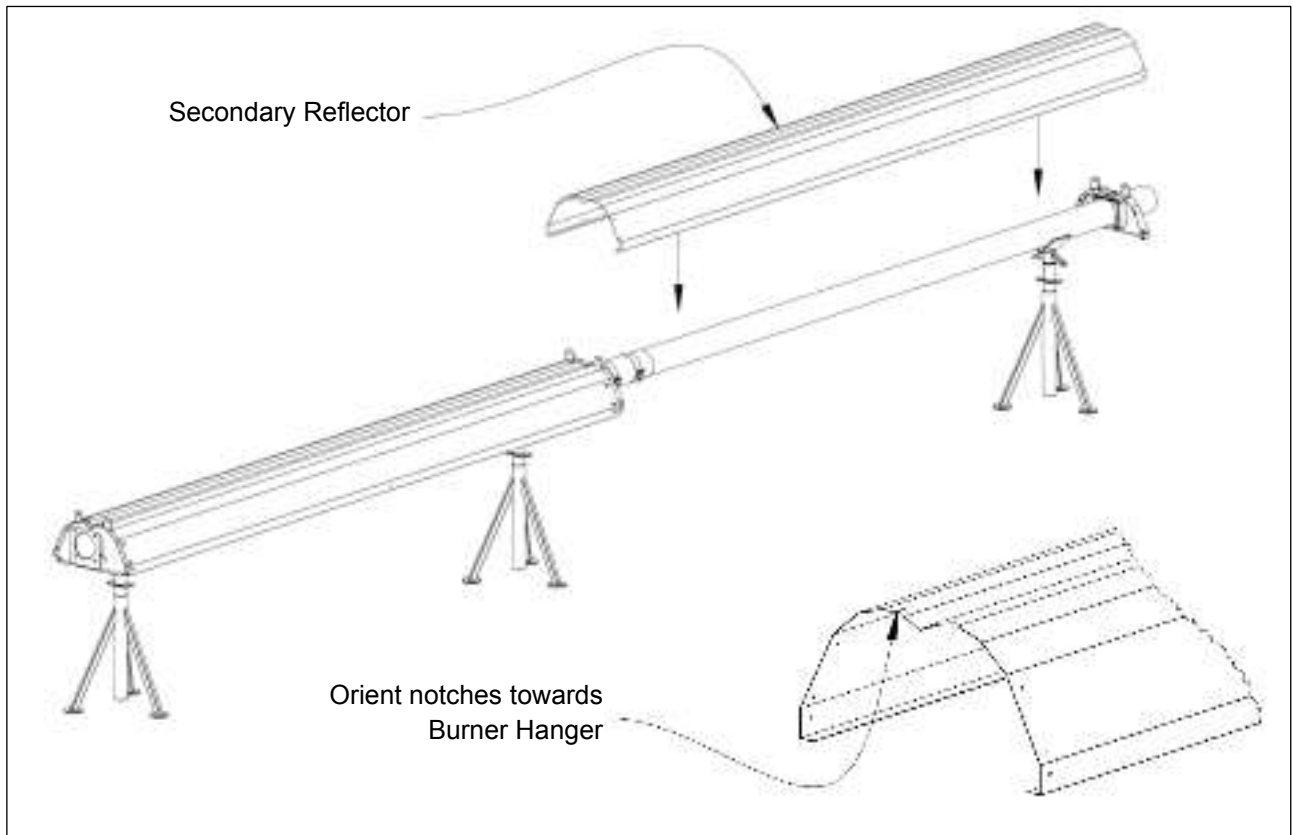

Step 13:

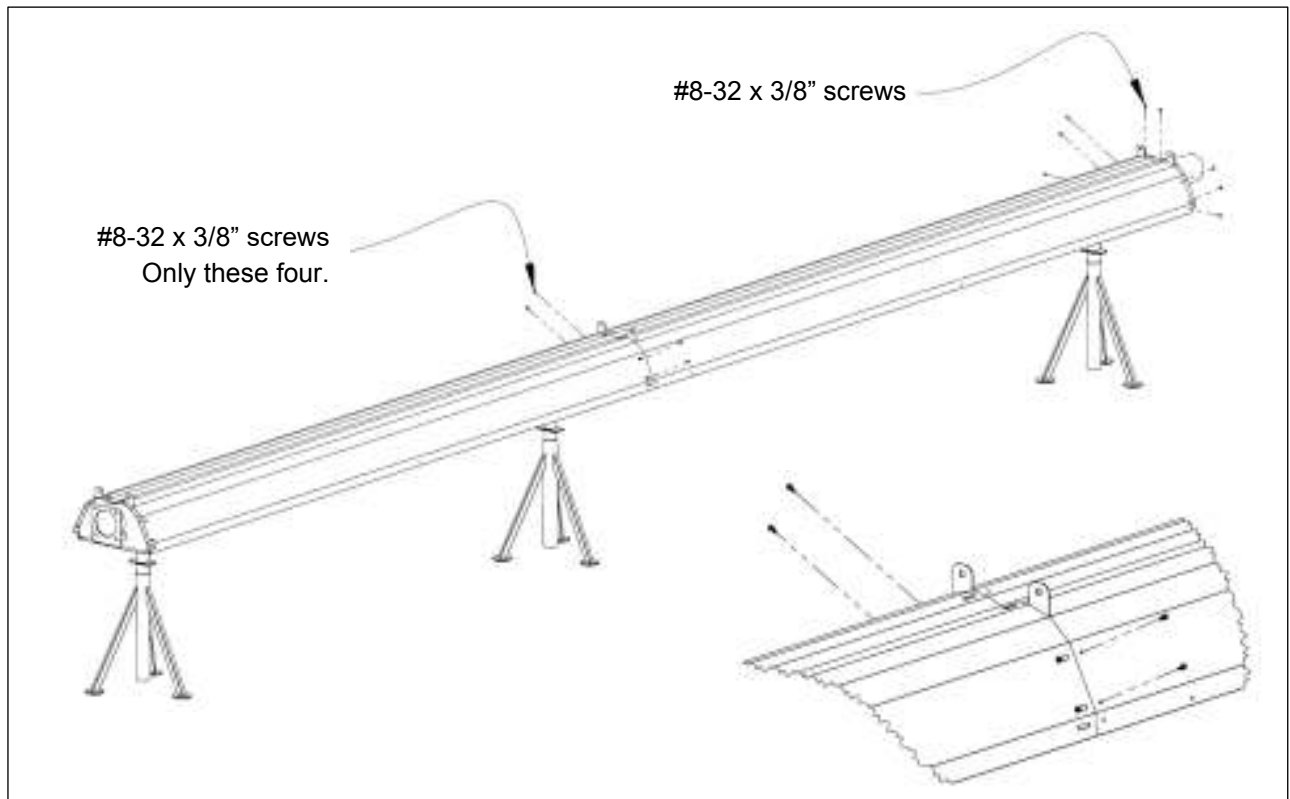

Step 14:

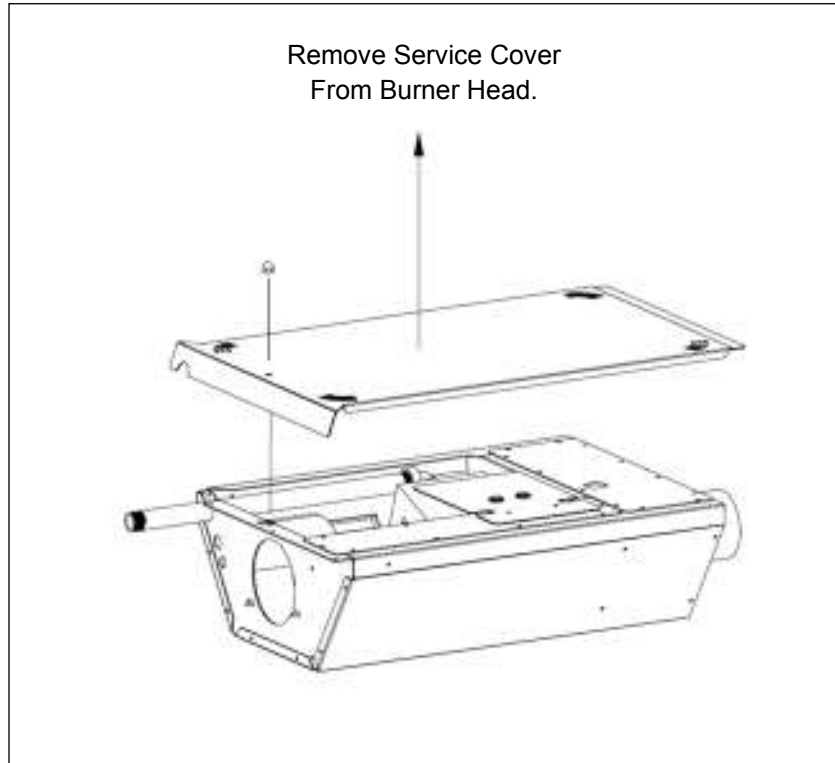

Step 15:

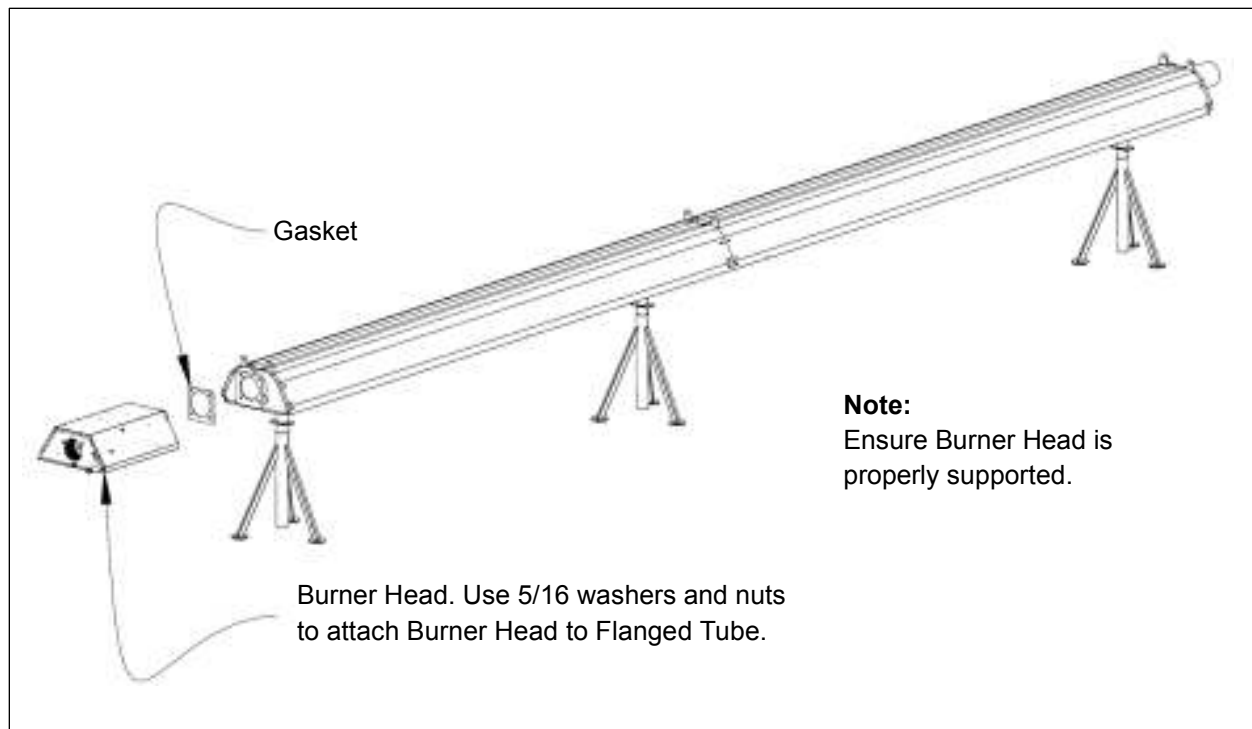

Step 16:

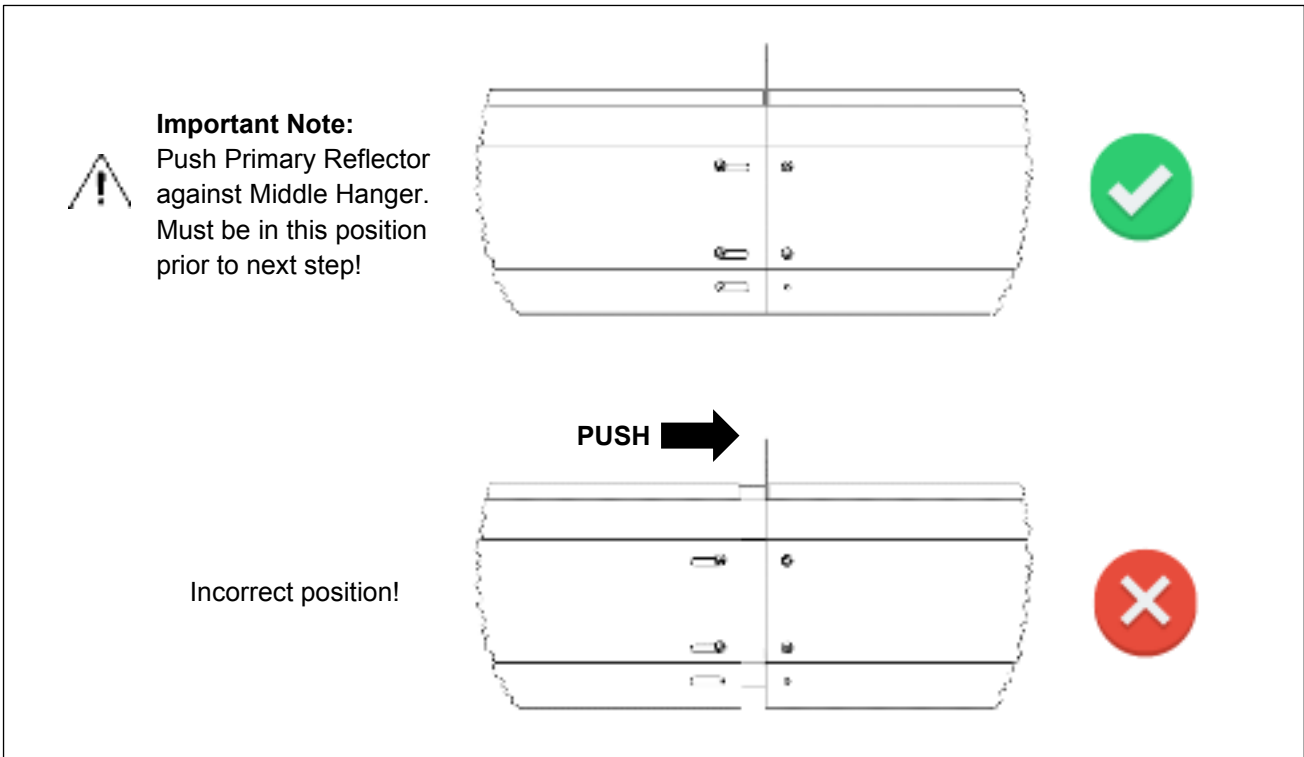

Step 17:

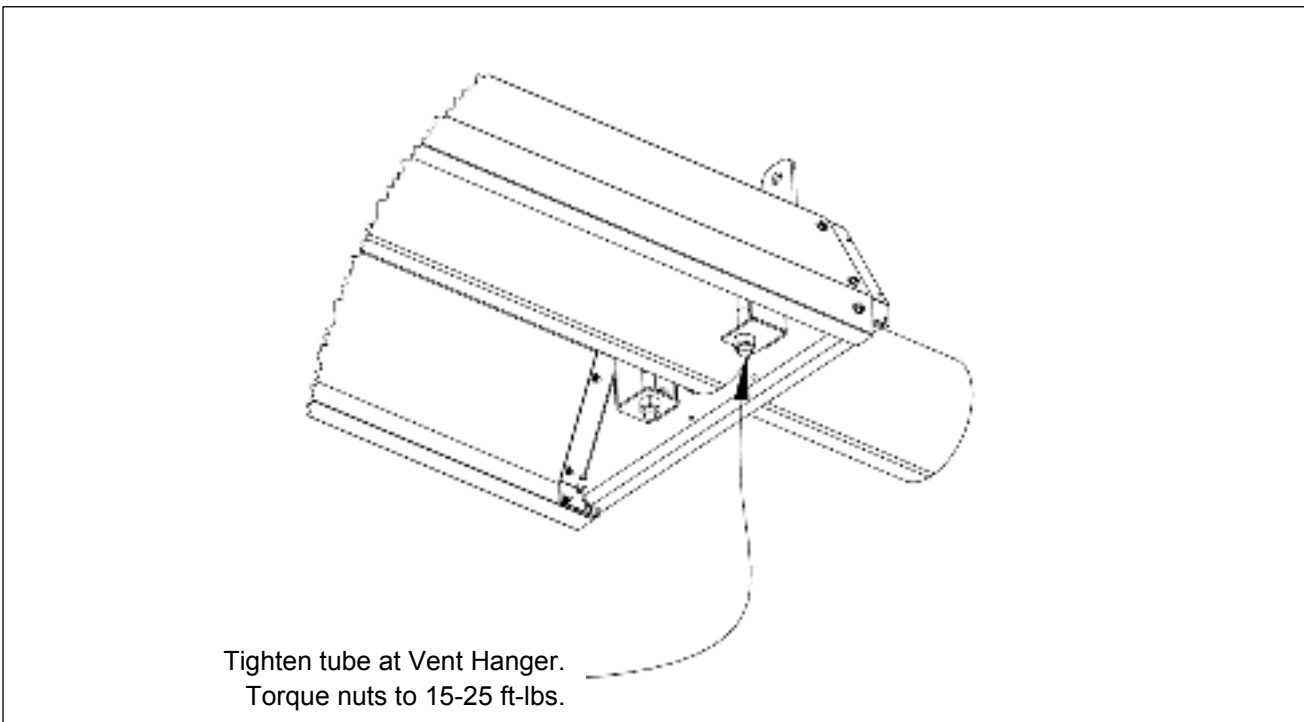

Step 18:

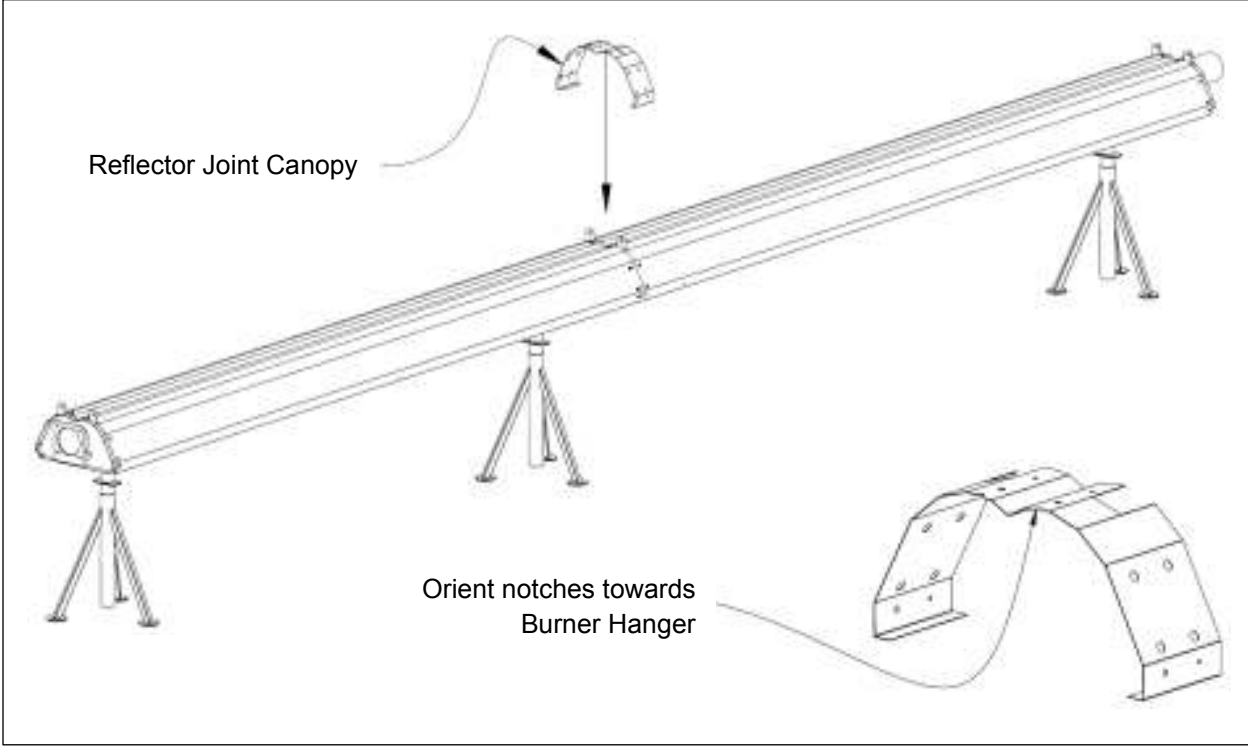

Step 19:

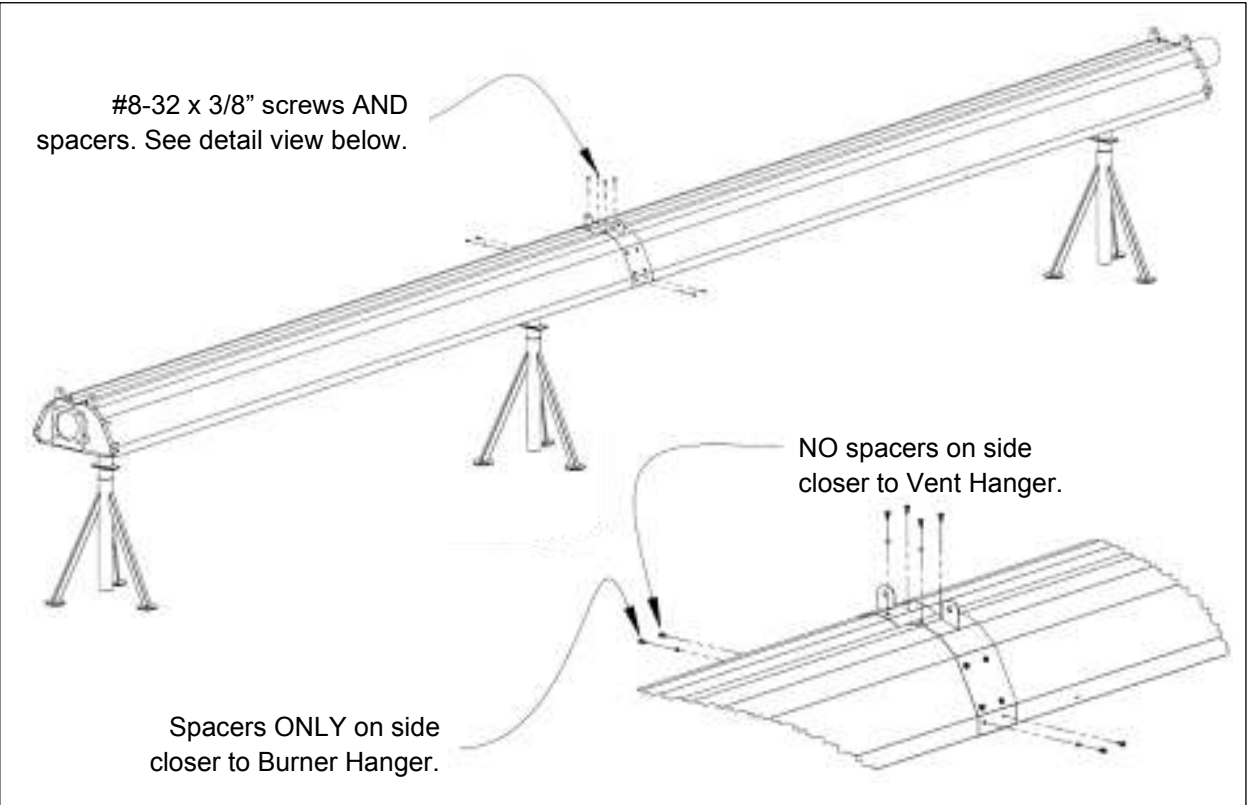

Step 20:

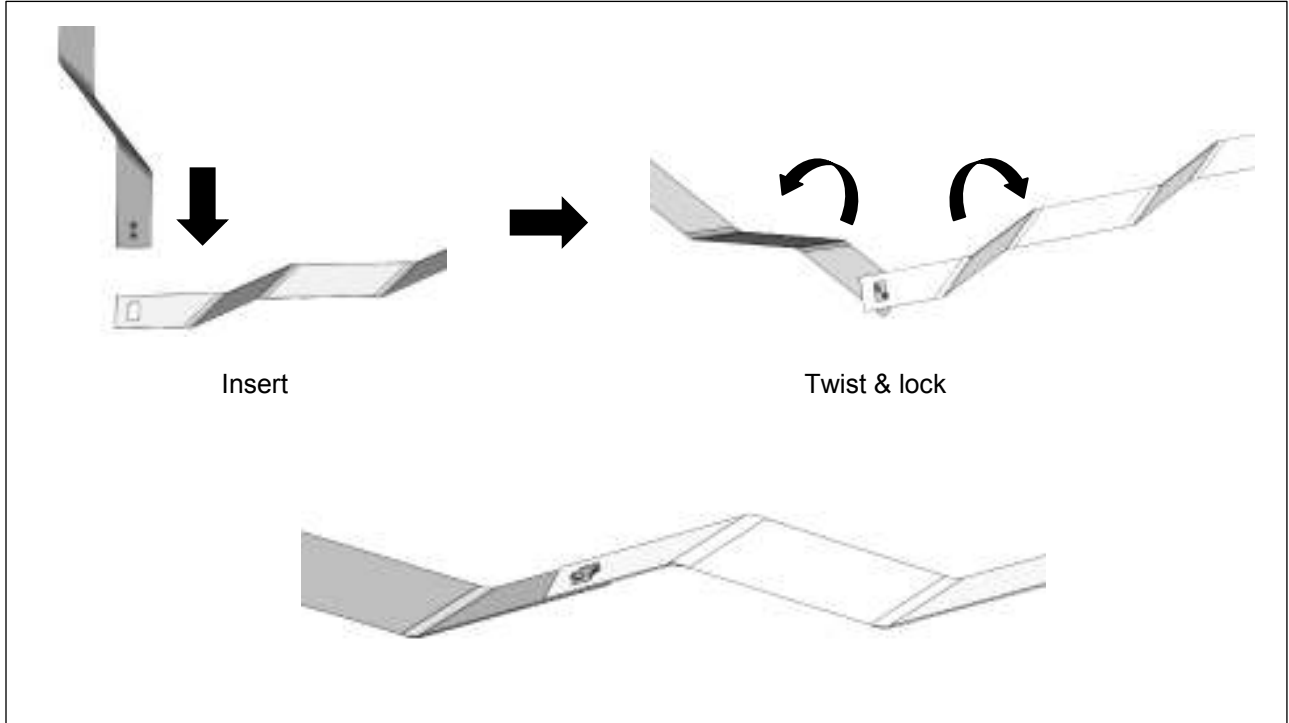

Step 21:

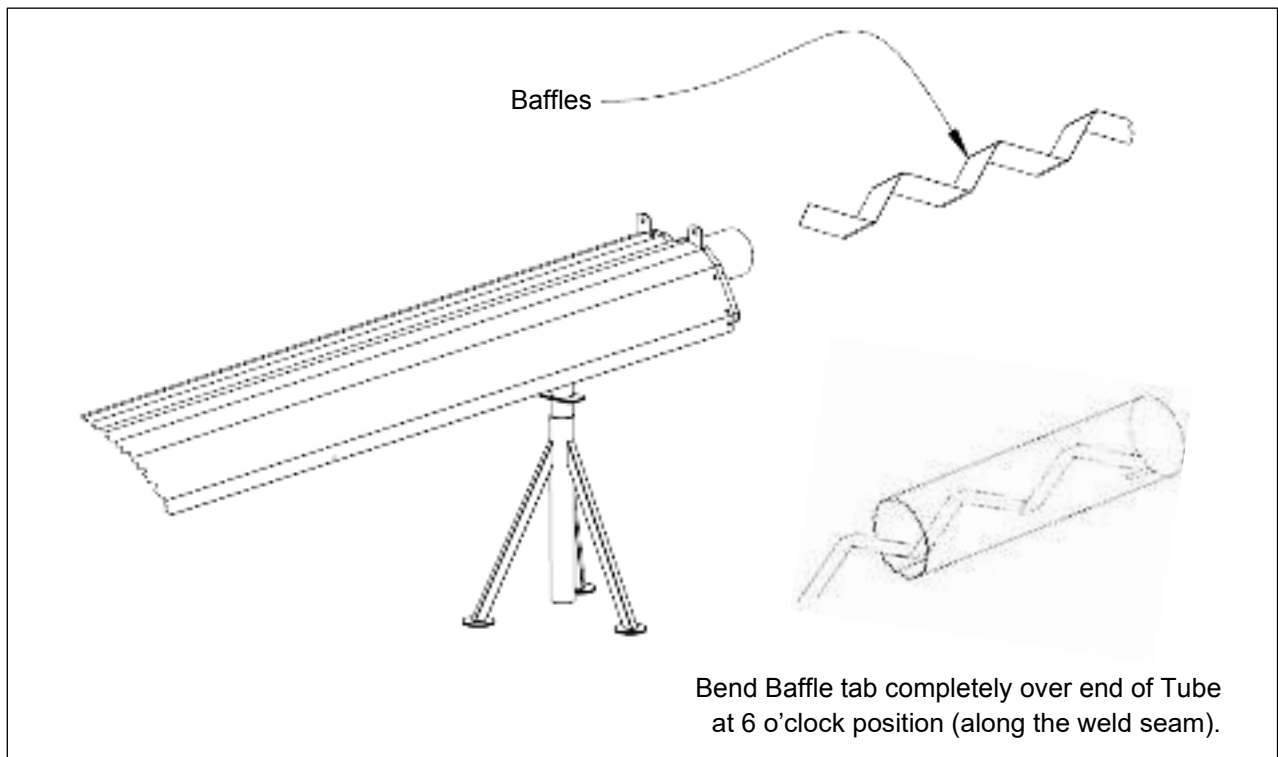

Step 22:

Slide Burner Head Reflector over Burner Head.

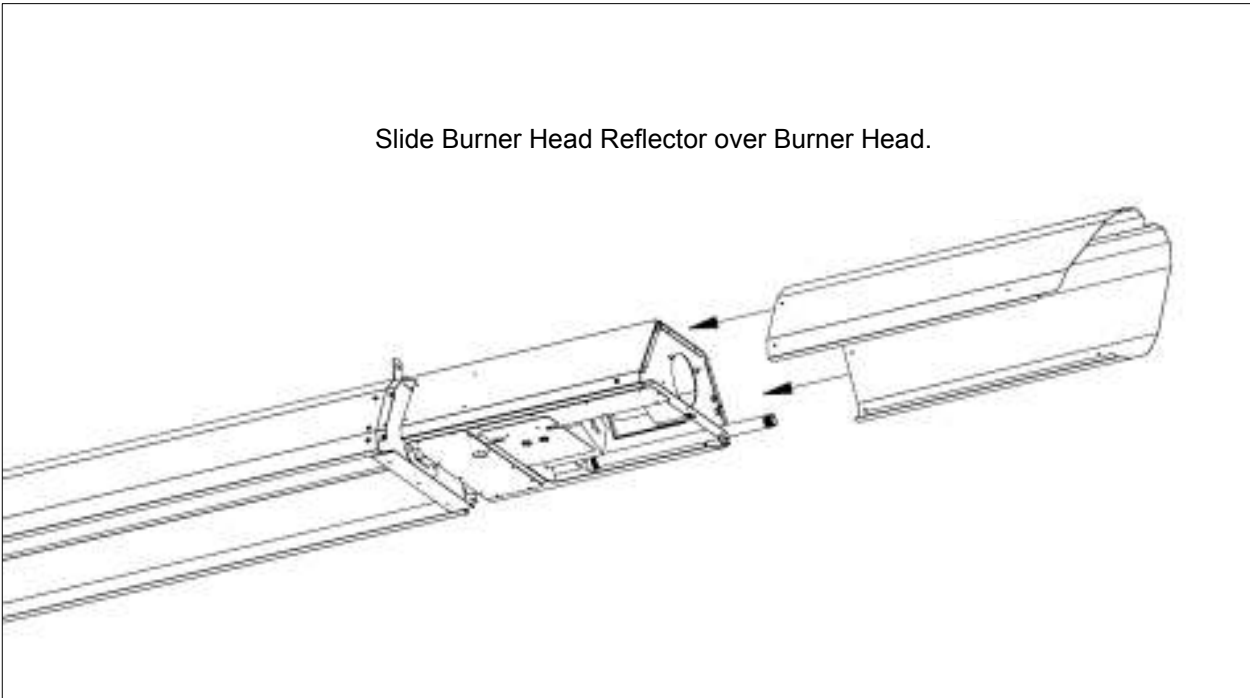

Step 23

#8-32 x 3/8" screws

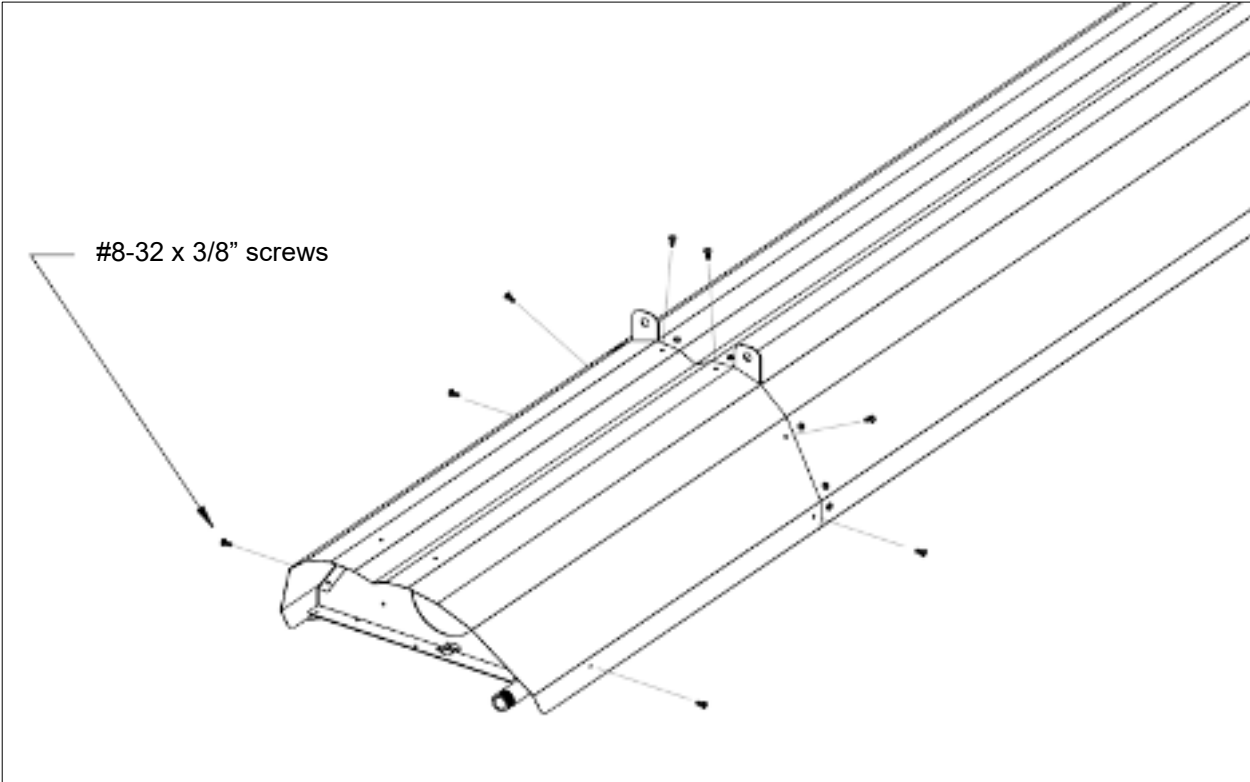

Step 24:



Attach Grill to Reflector and Burner Head.

Step 25:

#8-32 x 3/8" screws

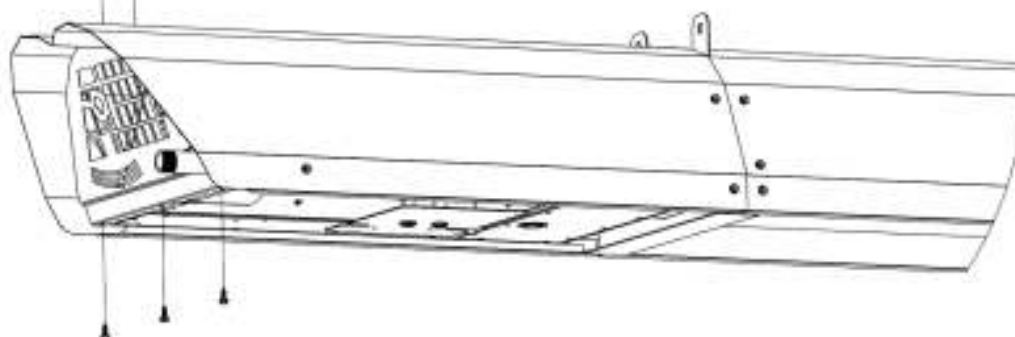

Step 26:

Re-attach Service Cover.

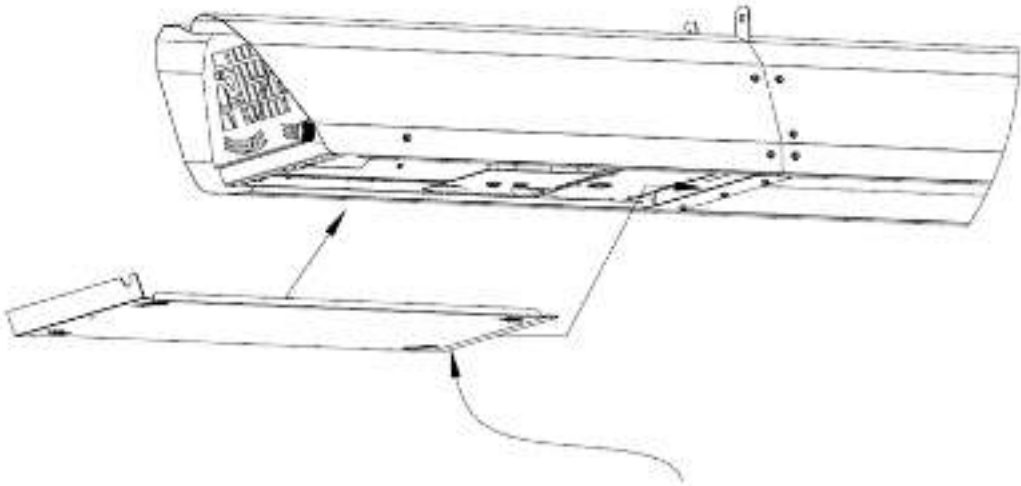

(tuck this edge up and in)

Step 27:

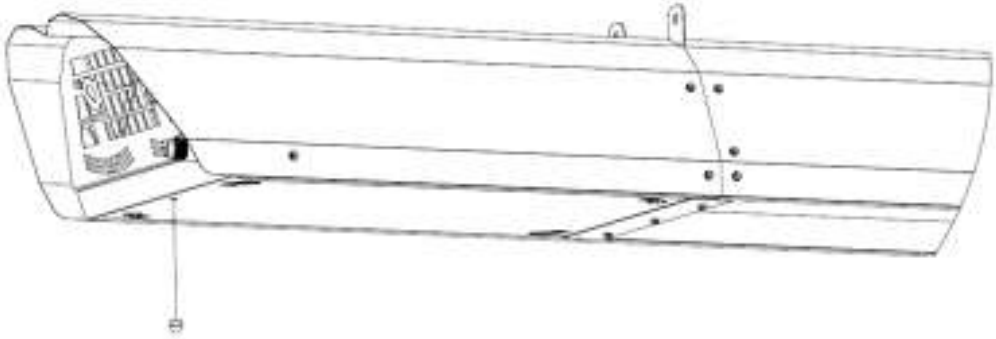

Fasten with acorn nut.

Step 28:

Before installing the Deco Grilles, **bend all the tabs** along one *long* side and both *short* sides of the Grille for easier fitment.

*Gloves recommended!



Step 29:

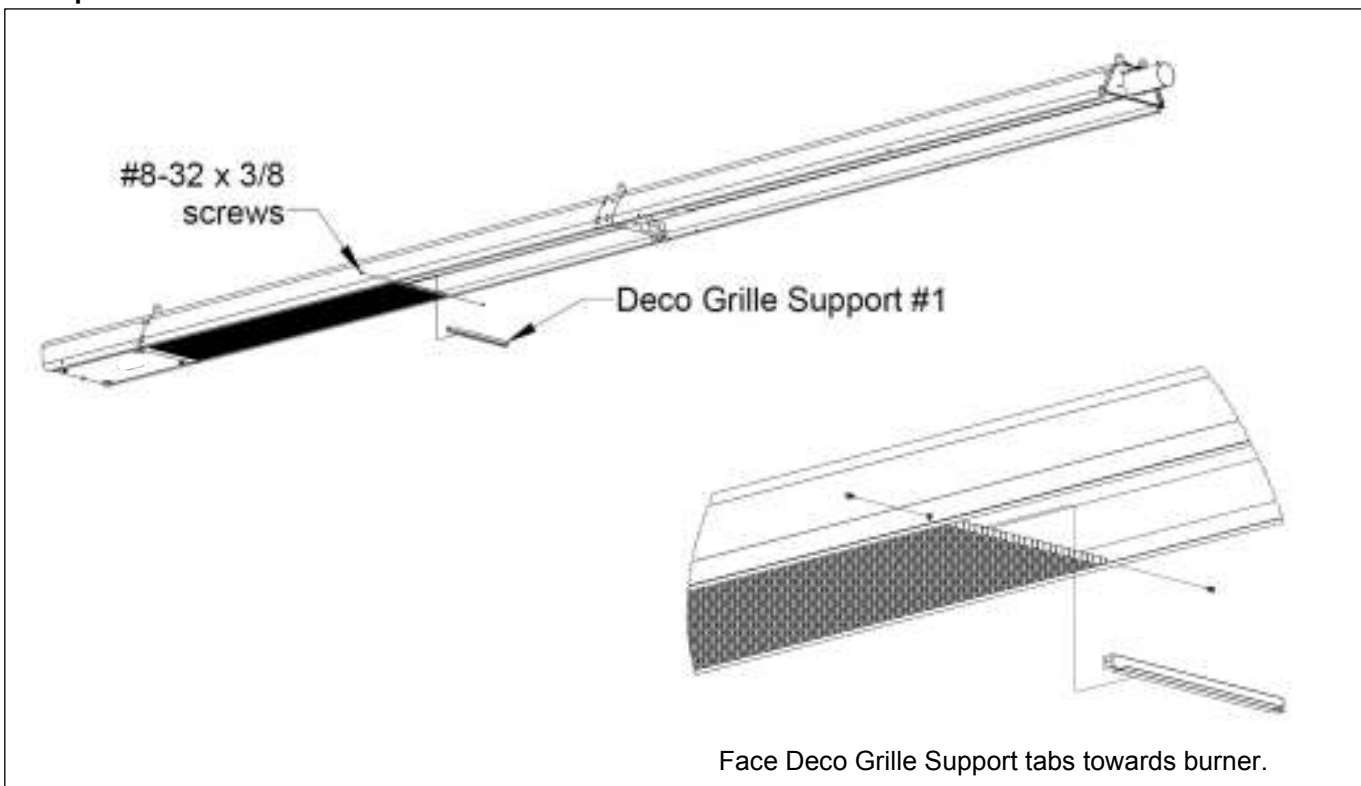

Step 30:

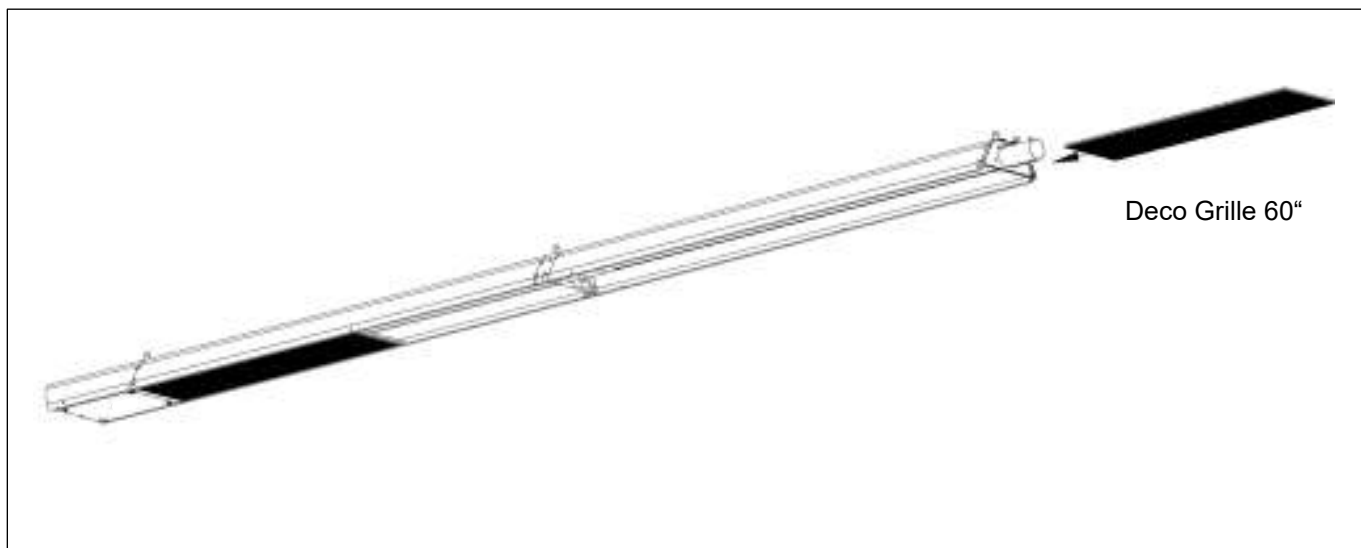

Step 31:

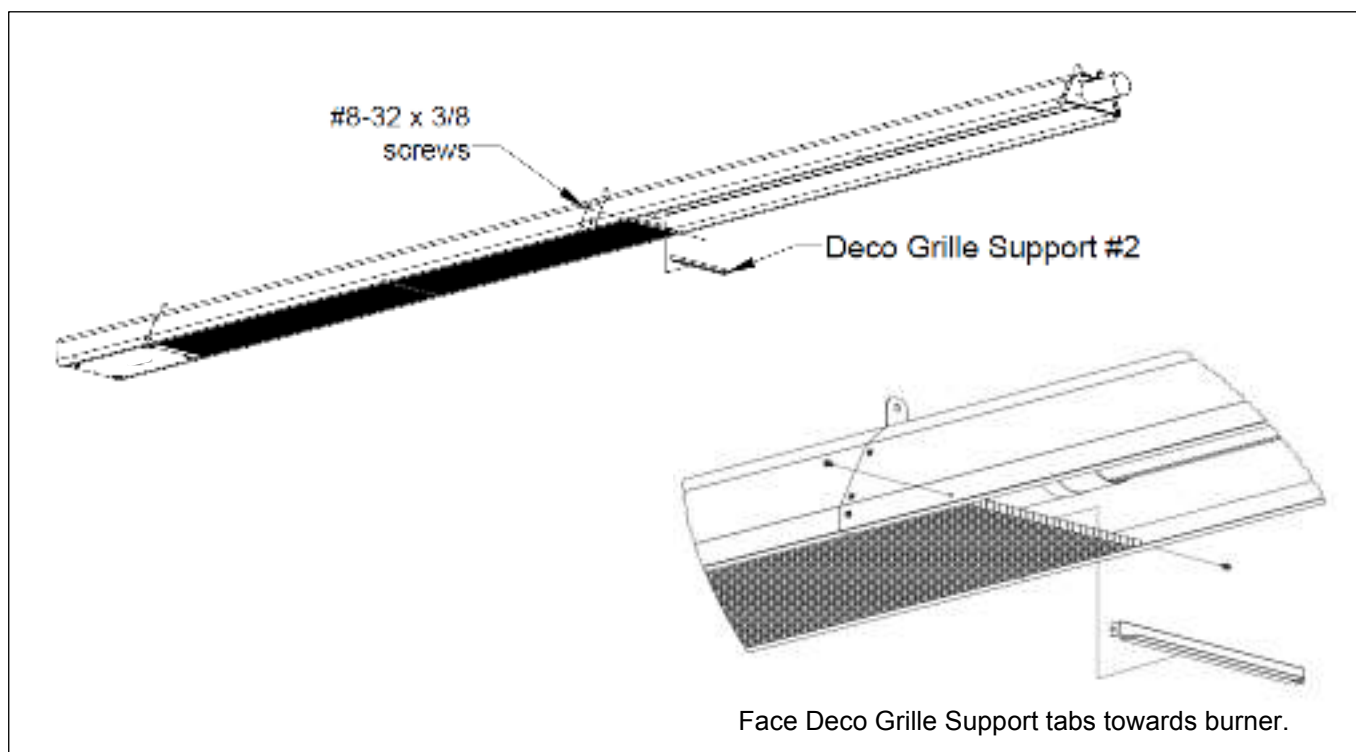

Step 32:

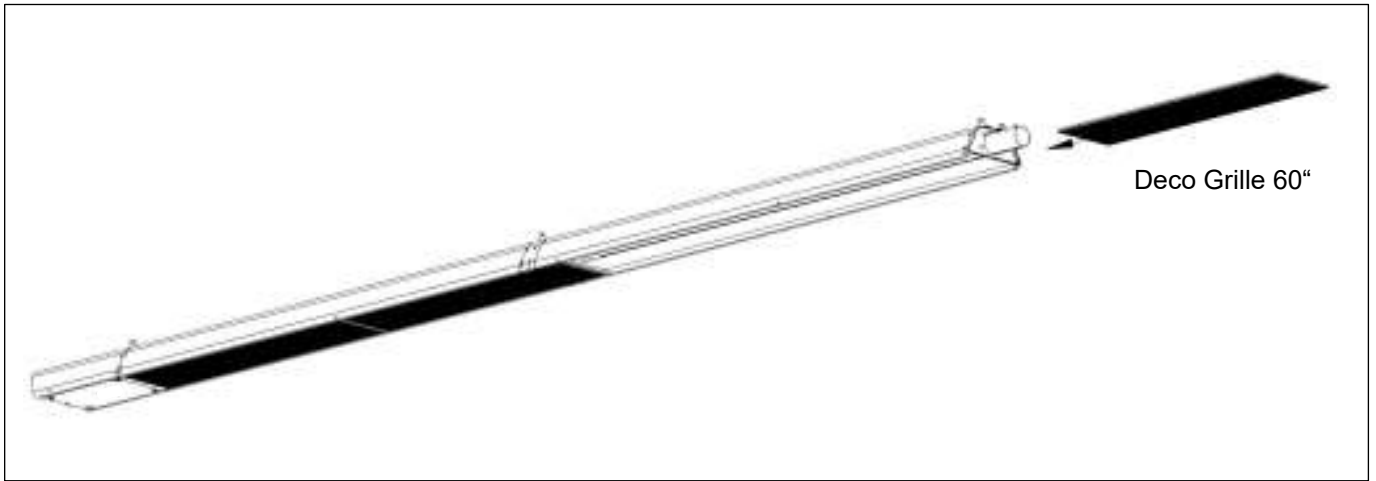

Step 33:

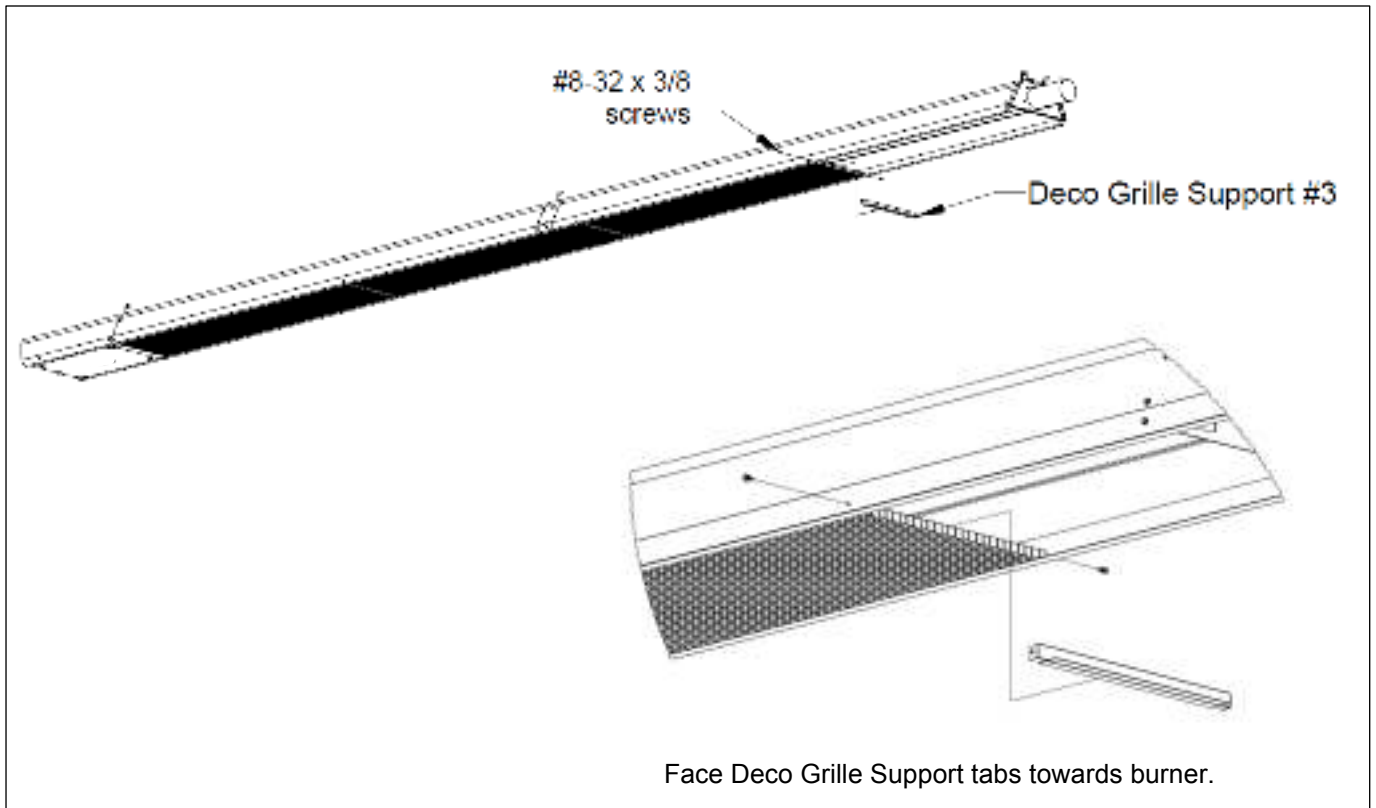

Step 34:

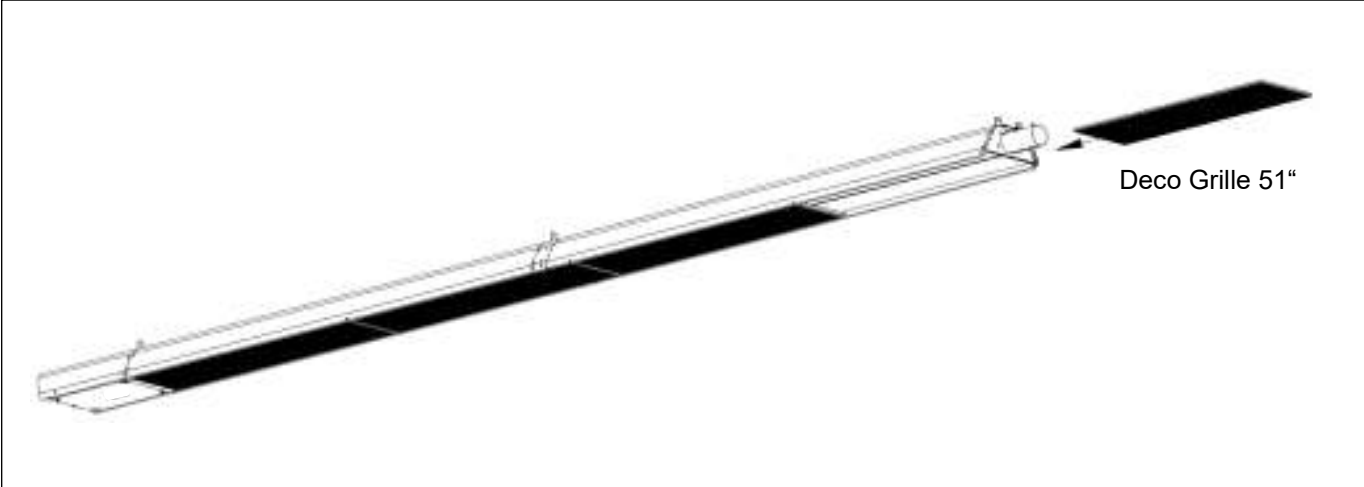

Step 35:

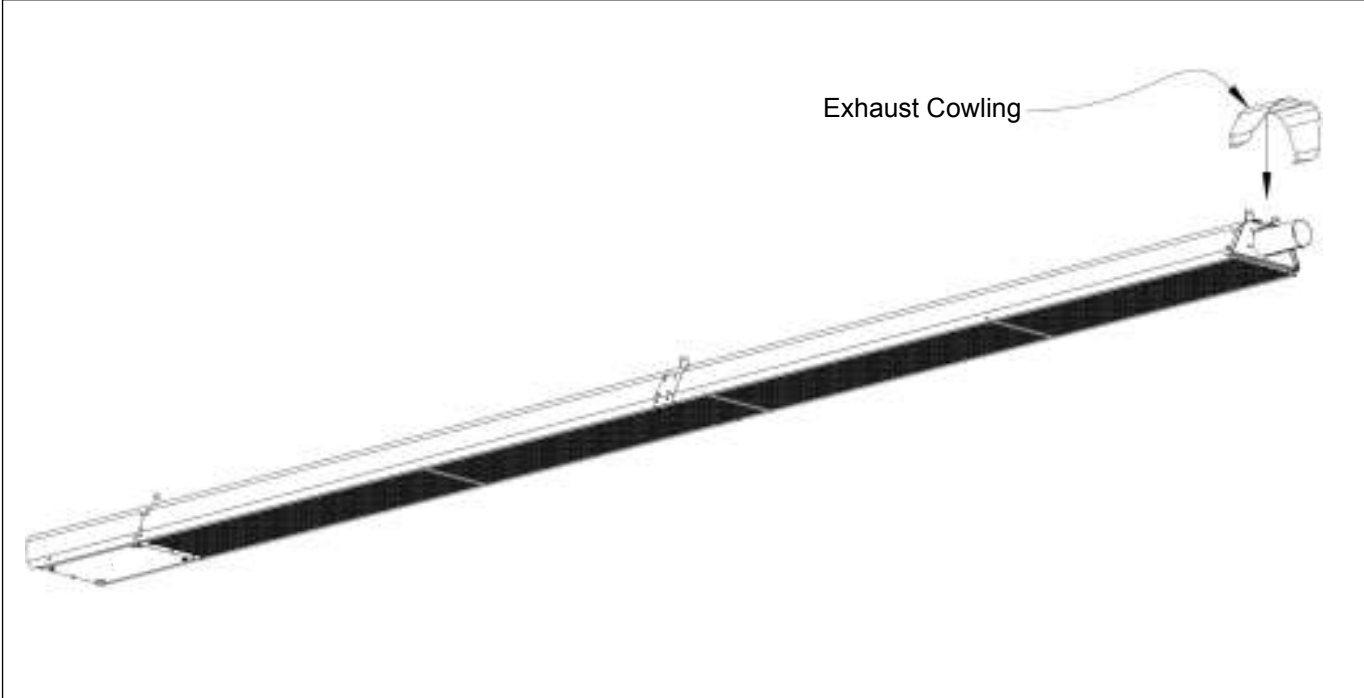

Step 36:

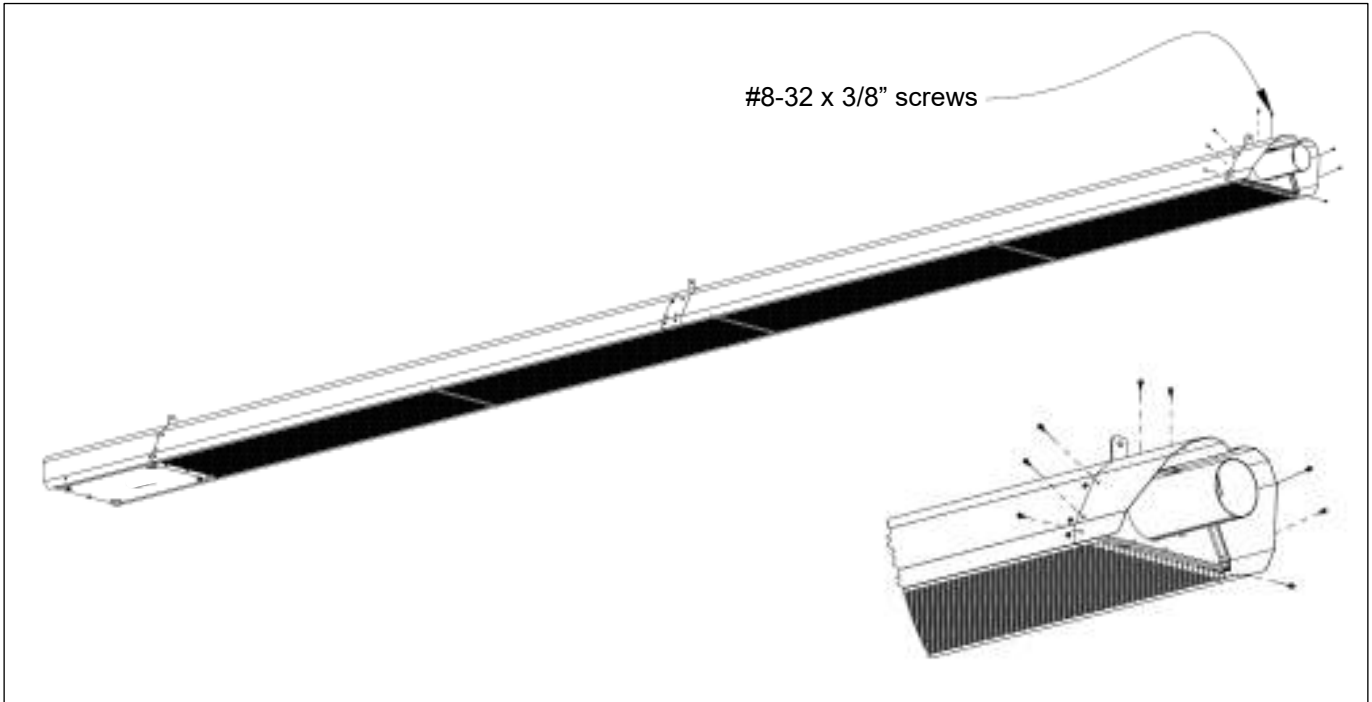

Step 37

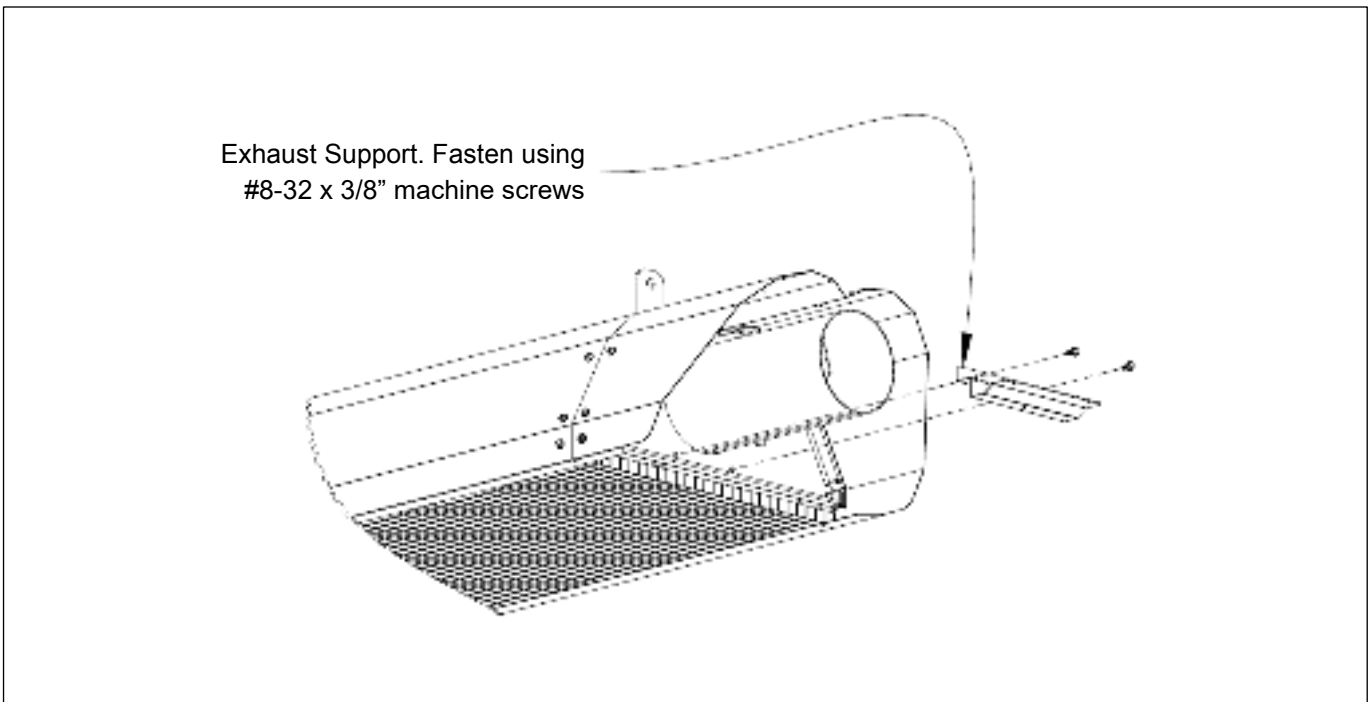

Step 38:

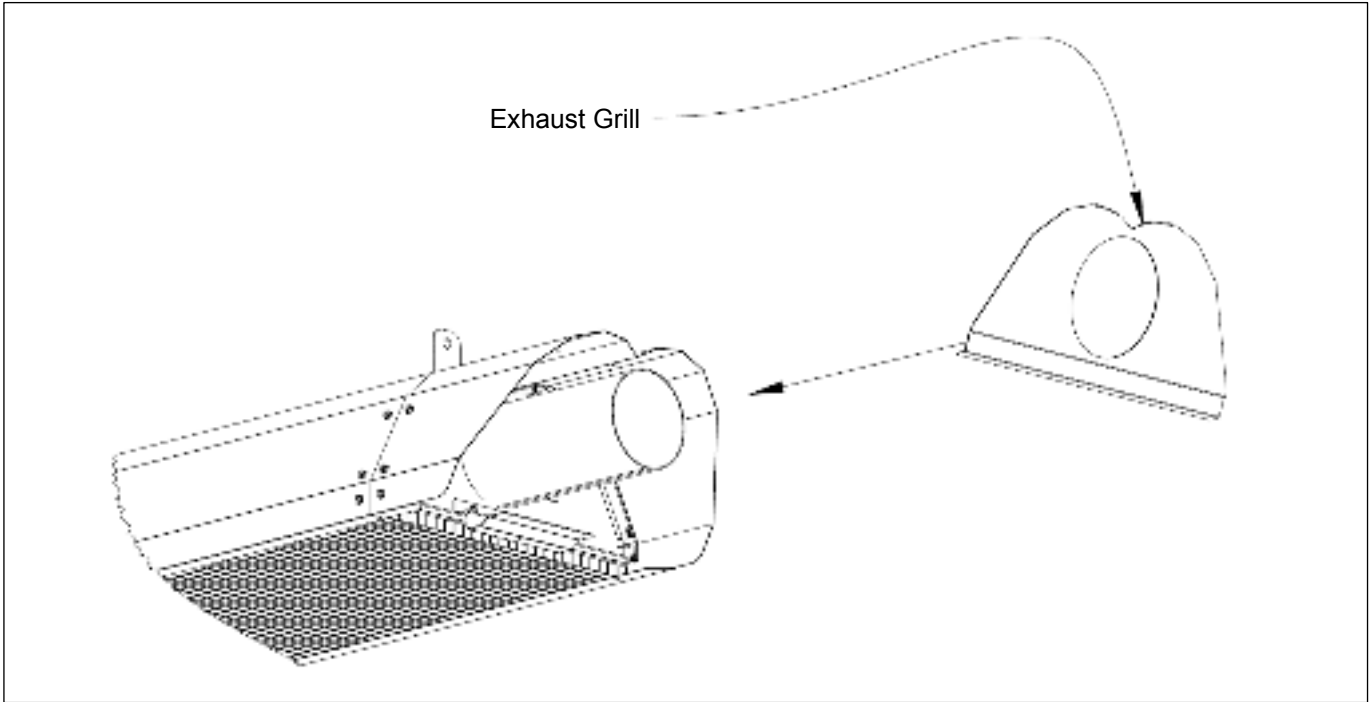

Step 39:

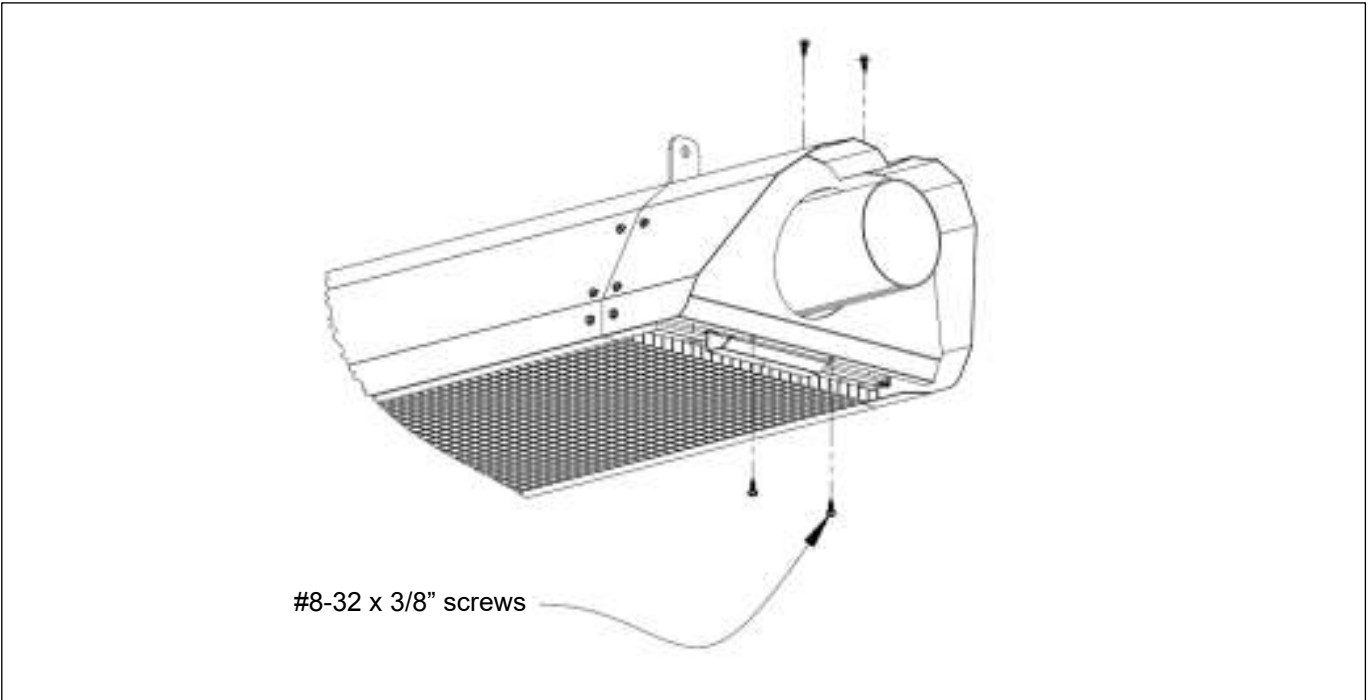

Step 40:

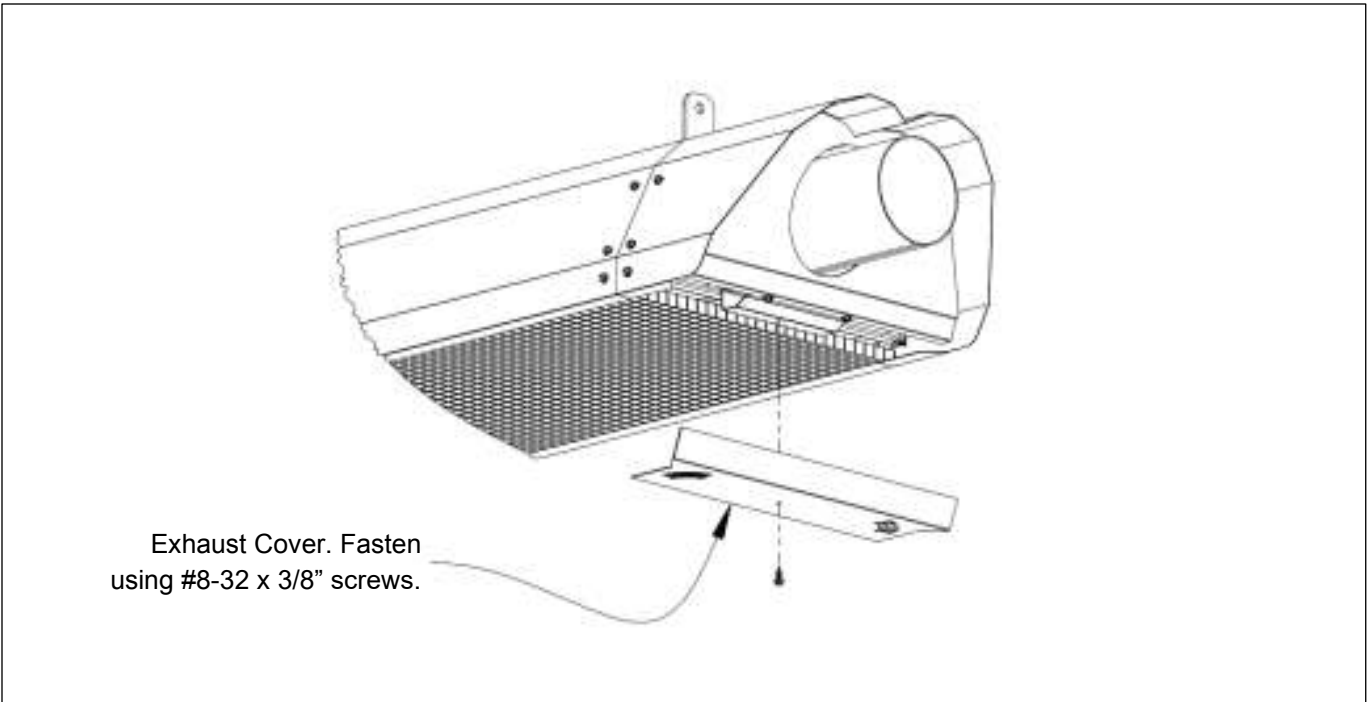

Step 41:

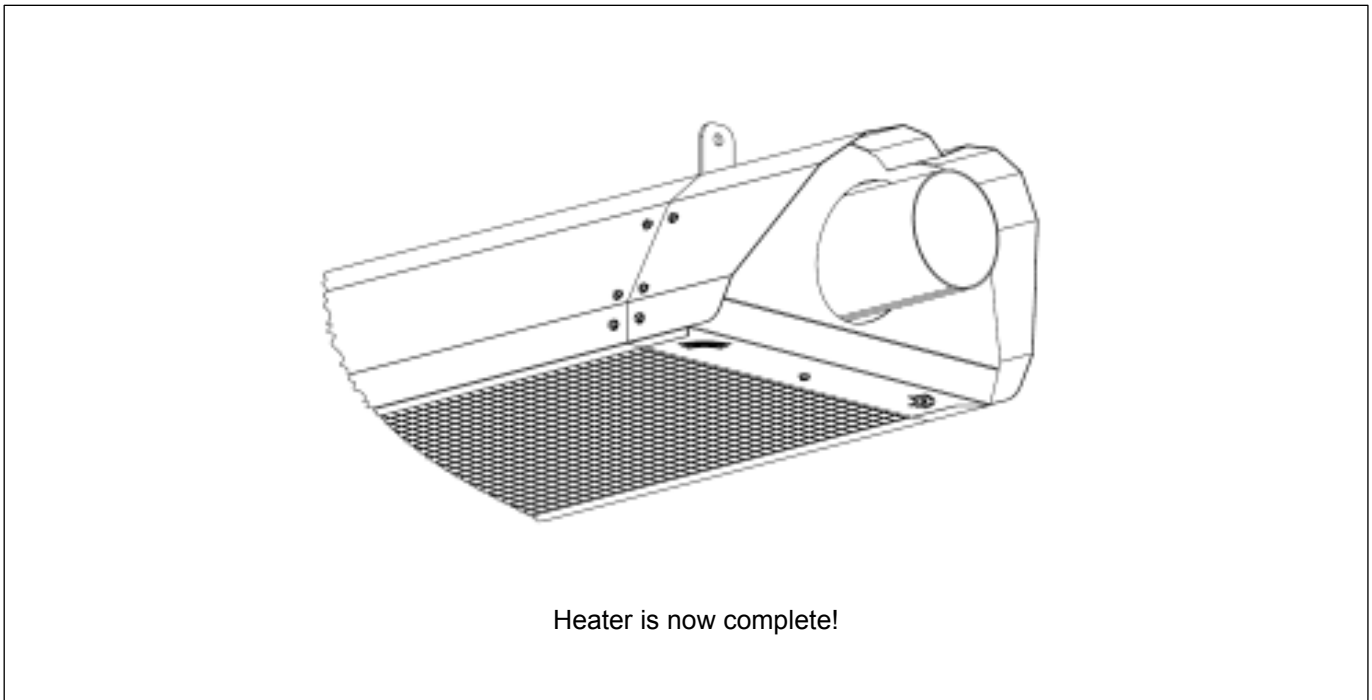

Gas Piping

Installation / Code Requirements

Installation must comply with local building codes and/or, for the USA/National Fuel Gas Code, ANZI Z 223.1 (NFPA 54) and for Canada, CSA B149.1 National Gas and Propane Installation Code (latest editions).

Appliance must be electrically grounded in accordance with local codes or, in their absence; the National Electrical Code, ANSI/NFPA 70 in the USA, CSA C22.1 Canadian Electrical Code in Canada.

Notes:

- Check for gas leaks at all connections with appropriate soap solution.
- Never connect an unregulated gas supply to the heater.
- Do not use high pressure (above ½ psig) to test the gas supply system with the appliance connected. Failure to comply can result in damage to the appliance.

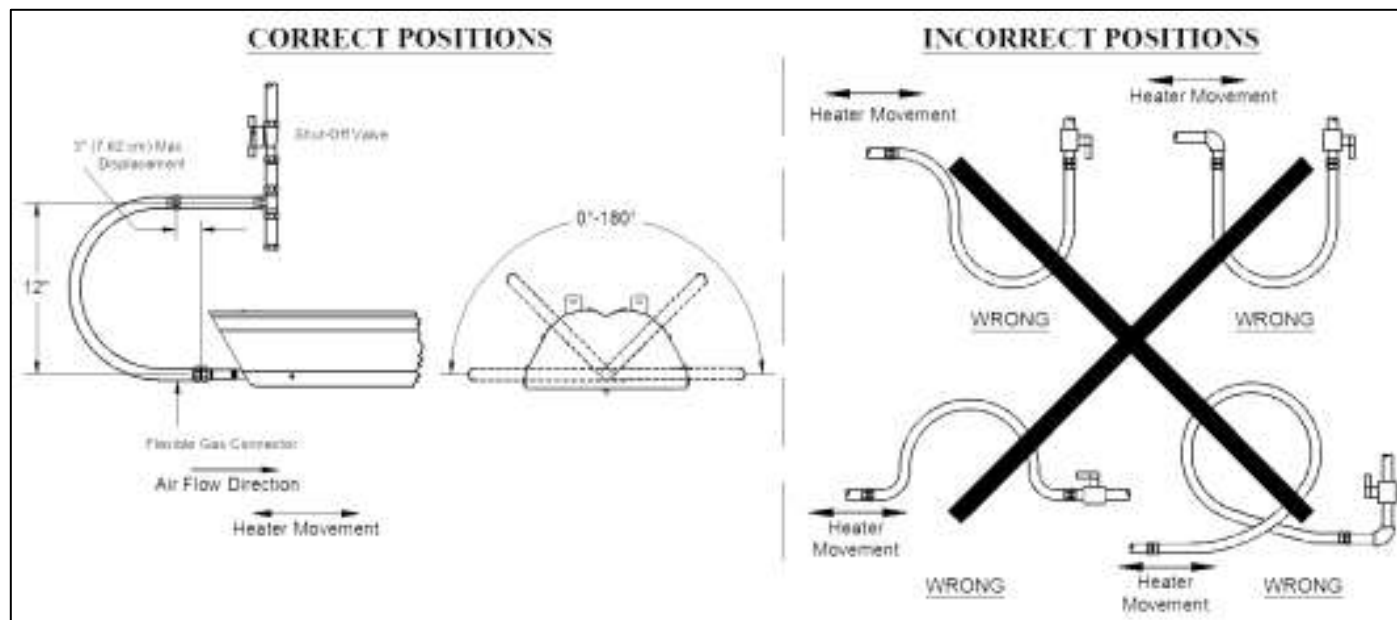

Electrical Wiring

General Requirements

Heaters are normally controlled by line voltage (120V) or low voltage (24V) thermostats. Line voltage thermostats are wired directly while low voltage thermostats use a relay. In all cases, heaters must be grounded in accordance with the *National Electric Code*, ANSI/NFPA 70 in the US, and the *Canadian Electric Code*, CSA C22.1 in Canada, and must comply with all local requirements. Heaters may also be controlled with a manual line switch or timer switch in place of the thermostat. Refer to wiring diagrams below for guidance on electrical wiring of heaters.

If any of the original wire as supplied with the heater must be replaced, it must be replaced with wiring having a rating of at least 105°C temperature service and 600 volts capability.

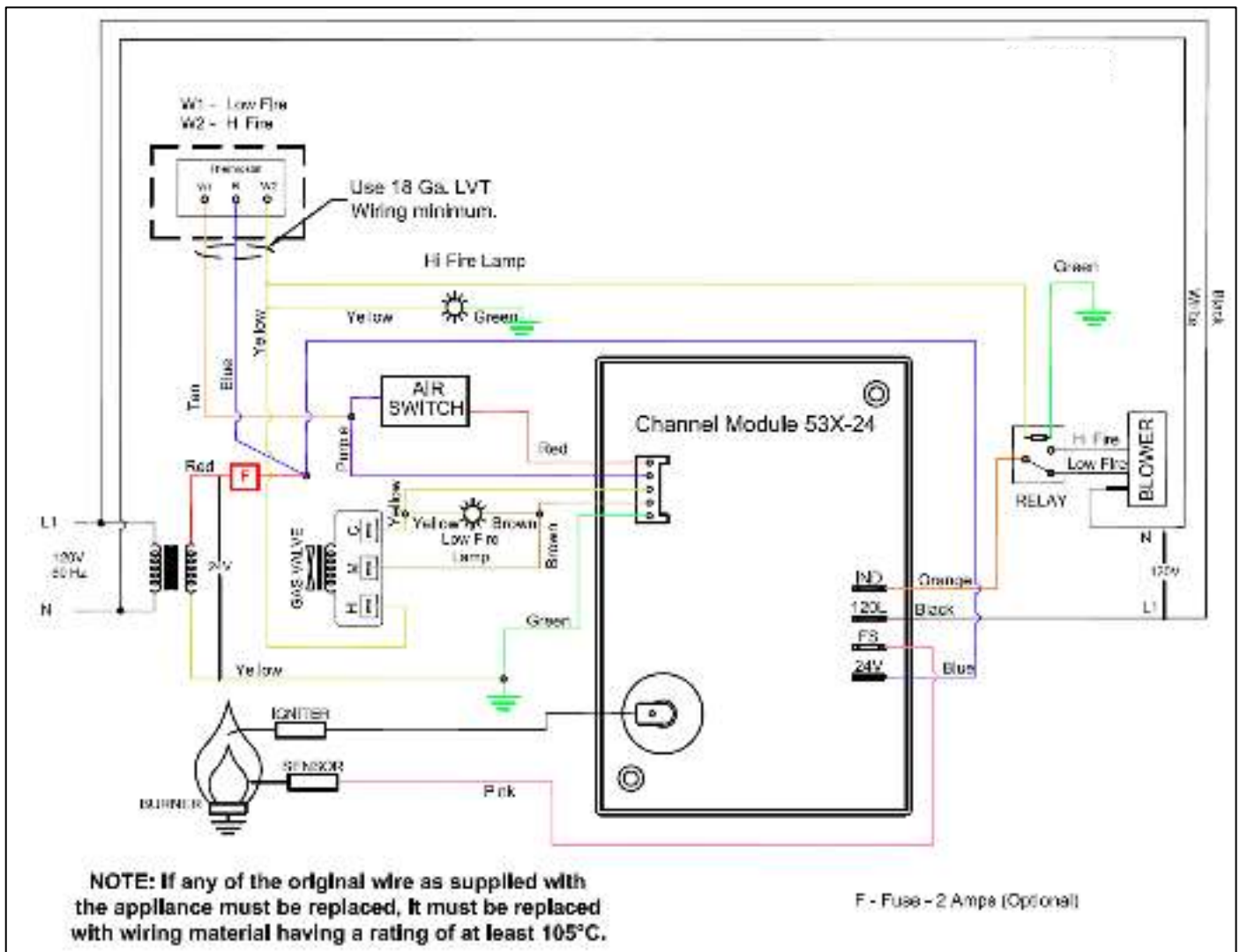

Multiple Heater Wiring (Thermostat)

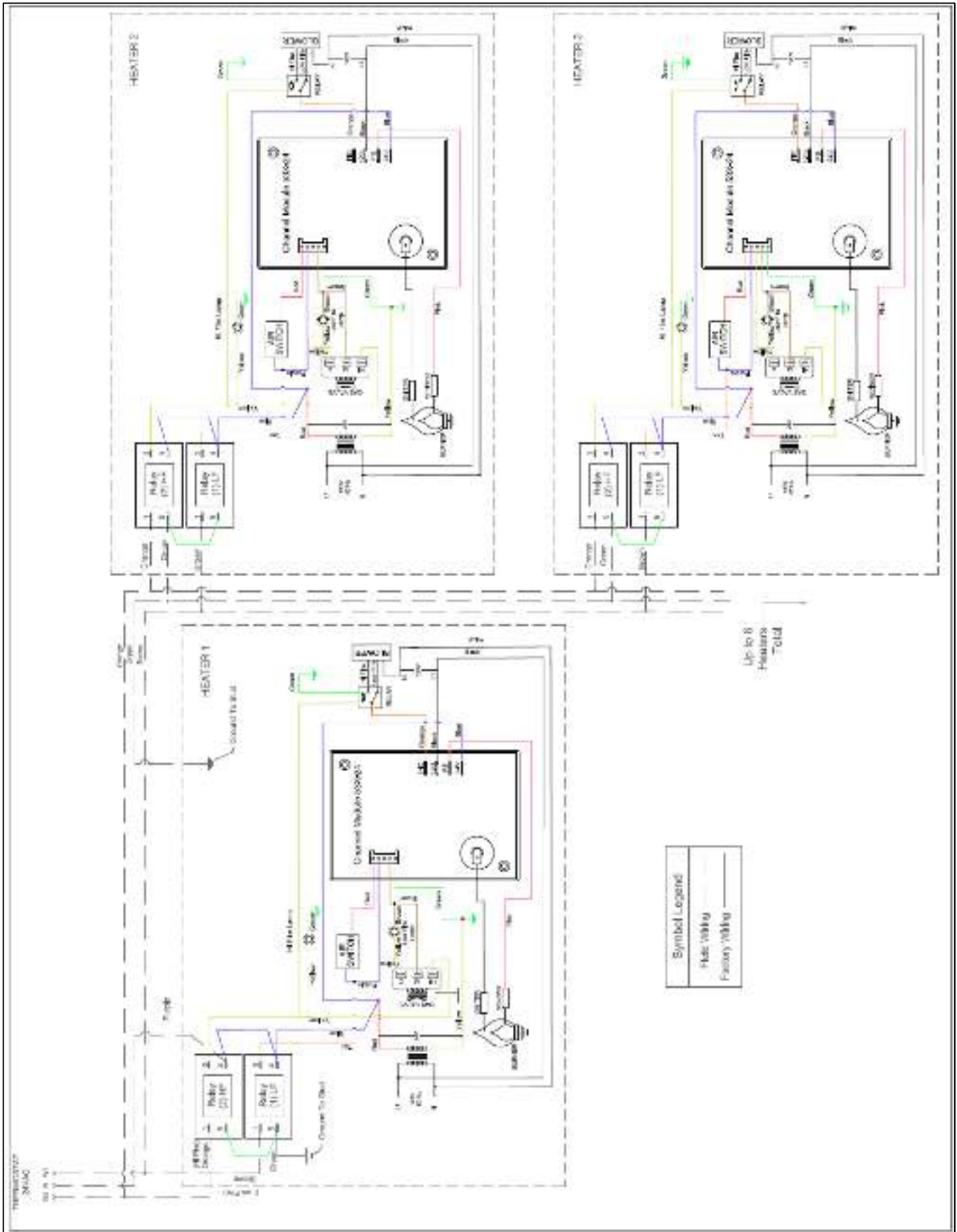

External Wiring Options (Outdoor Installation Only)

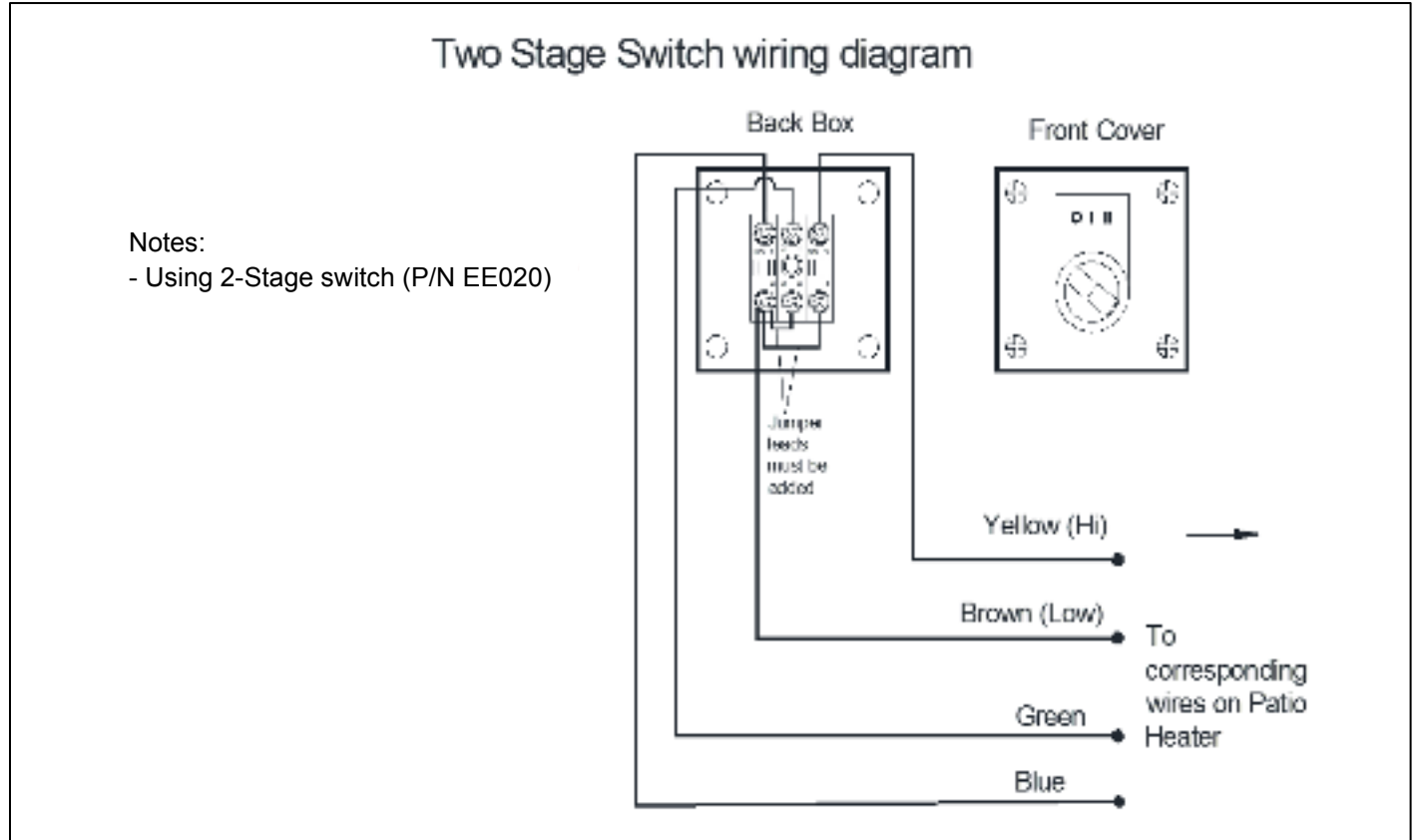

Vented Operation

General Requirements

- Refer to the National Fuel Gas Code, ANSI Z223.1 (NFPA 54) in the USA and CSA B149.1 Installation Codes in Canada, as well as all local requirements for general venting guidance.
- Series ETSV Heaters may be installed vented or unvented.
- Series ETSV Heaters may be vented horizontally or vertically. This series of heaters are considered a Category I appliance for vertical venting and a Category III appliance for horizontal venting.
- If heater is to be vented horizontally, the vent from building must:
 - Be not less than seven feet above grade when located adjacent to public walkways.
 - Terminate at least three feet above any forced air inlet located within ten feet.
 - Terminate at least four feet below, four feet horizontally from or one foot above any door, window, or gravity inlet into any building.
 - Be located at least 12" (30cm) from any opening through which vent gases could enter a building.
 - Extend beyond any combustible overhang.
 - Be installed at a height sufficient to prevent blockage by snow.
- Secure all joints with three sheet metal screws.
- Optional outside air supply may be directed to the heater horizontally or vertically.

IMPORTANT

- Maximum total vent length allowed for any model heater is 15' (3m).
- Maximum total fresh air inlet duct length allowed for any model heater is 15' (3m).
- Total of vent length plus outside air supply duct length cannot exceed 30' (6m) for any heater.
- If condensation in the vent pipe or outside air supply duct is a problem, shorten or adequately insulate the section.

Note: The above stated requirements assume a maximum of 2 elbows in the total combination of vent and air supply duct. Subtract 5' of allowable length for each elbow if 3 or more elbows are used.

Un-Vented Operation

- Requirements for combustion air supply and dilution air vary by jurisdiction, building type and specific installation details. See local codes for guidance. In general, fresh air ventilation must be provided to the building space at 3 cfm per 1000 BTU/Hr in Canada and 4 cfm per 1000 BTU/h in USA. The exhaust fan must be electrically interlocked with the heater.
- Optional outside air supply is not recommended for unvented heaters due to possible pressure imbalances in the building space.
- Ensure that minimum combustible clearances are maintained for unvented heaters. Refer to Clearance to Combustibles, for required clearance dimensions.

Vented Operation

Horizontal Venting

- The heater operates at a positive vent pressure.
- Use an approved to S636 or UL1738 Category III venting system, or a single wall vent pipe with all joints and seams sealed with heat-resistant pliable sealant, such as high temperature RTV silicone for temperatures up to 650°F [343°C]. Prior to placing the heater in operation conduct a leak test with heater running using a soap solution.
- When venting through combustible walls, use approved vent terminal Tjernlund VH1-4, or IR Energy supplied deflector vent terminal with an approved insulating thimble.
- When venting through non-combustible walls, use IR Energy supplied deflector vent terminal. Recommended extension of the terminal past the outside wall surface is 18" minimum.

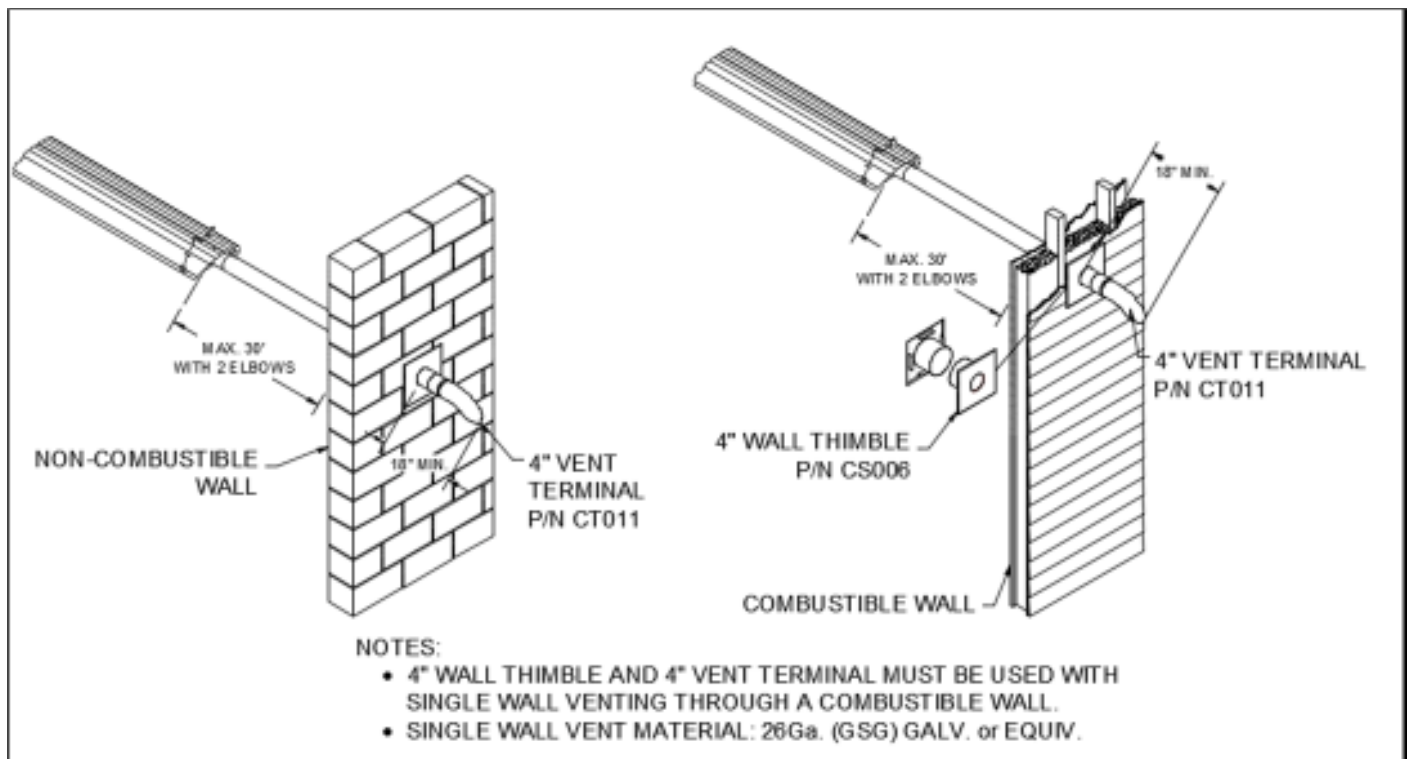

Vertical Venting

- The heater operates at a negative vent pressure.
- Refer to the National Fuel Gas Code, ANSI Z223.1 (NFPA 54) in the USA and CSA B149.1 Installation Codes in Canada, to size for Category I (B-vent) fan assisted appliances.
- Minimum vent pipe size is 4"(10cm) for an individual heater
- Use of an approved thimble to pass through combustible roof materials is required.
- Use of an approved vent cap is required.
- Check local codes for vertical vent size.

Common Vertical Venting

- Common vent sizing information is defined in the appropriate gas installation code (Refer to ANSI Z223.1 and CSA B149.1 for sizes and installation information).

- Connection locations to the common vent should be offset to avoid pressure interferences between heaters, refer to ANSI Z223.1 and CSA B149.1.
- Use of approved thimble to pass through combustible roof material is required. Additionally, B type vent materials are required for stacks above the roof line. Use of approved vent cap is required.
- All heaters to a common vent are recommended to operate at the same time. Connect the electrical circuit to the same thermostat to ensure simultaneous operation.

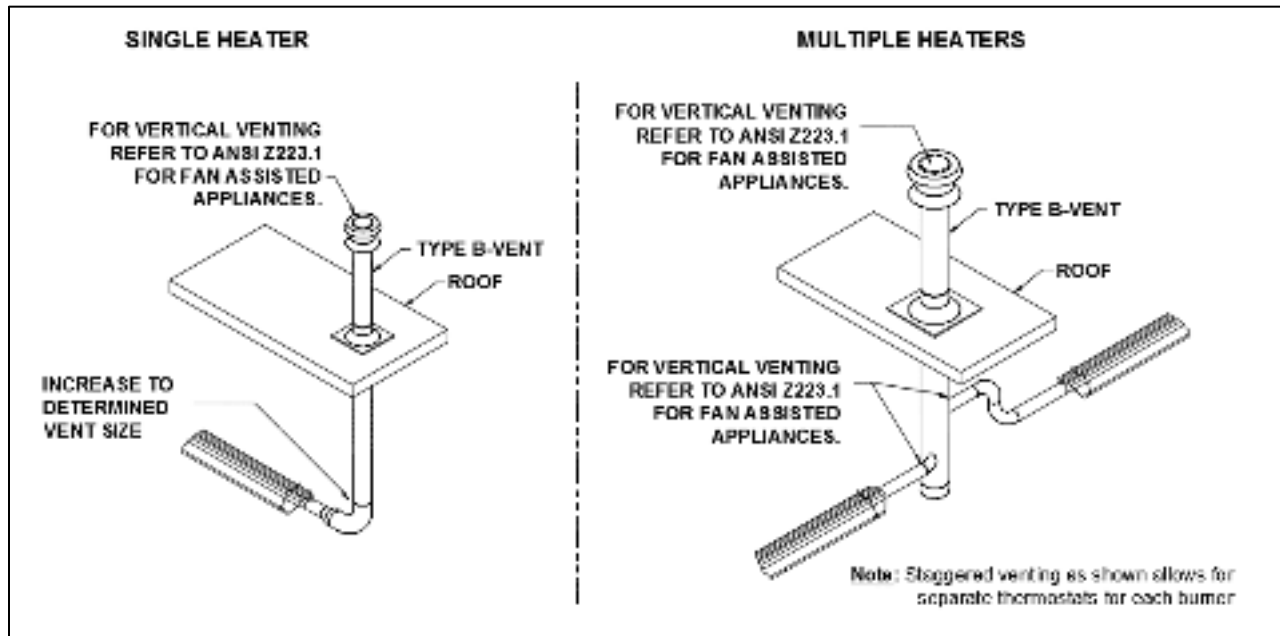

Note: Horizontally vented heaters must be individually vented and cannot use a common vent.

Combustion Air Supply (Optional)

- An outside combustion air supply is strongly recommended if the building space encloses a negative pressure due to exhaust etc. or if the building contains materials which would expose the heater to halogenated hydrocarbon atmospheres.
- The outside air terminal must be of an approved type and should be located at an elevation equal to or below the vent terminal elevation to prevent back-venting of flue gases into the burner compartment.
- Install single wall pipe or PVC pipe and fittings with a 12" linear section of flexible duct to allow movement of the heater. Do not use flexible duct throughout the entire length of fresh air duct. This may cause nuisance air switch tripping.
- Optional: Fresh Air Kit #CT168

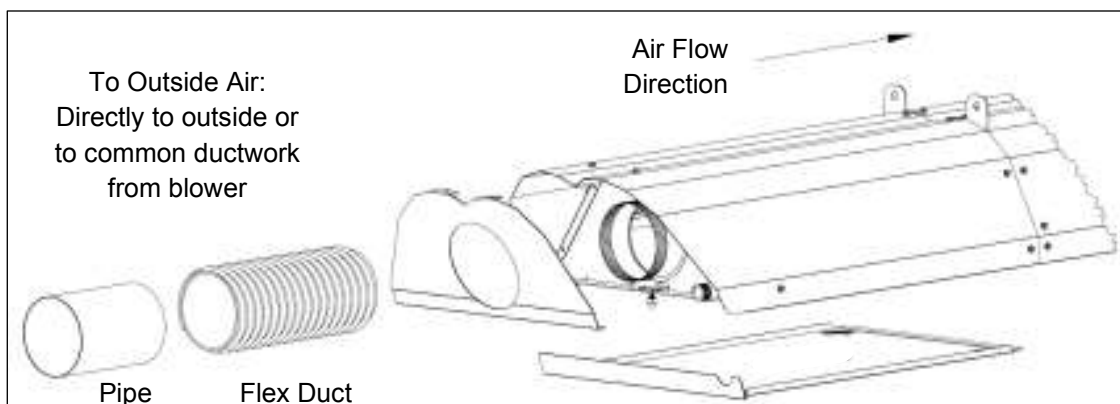

Outdoor Installation

When a heater is to be mounted outdoors it must be installed in such a way that wind will have minimum effect on its movement. This consideration is intended to eliminate undue stress on the gas flex connector. A vent terminal of the approved type (Kit # CT011) must be used and all connections must be sealed with a high temperature sealant that can withstand 400°F.

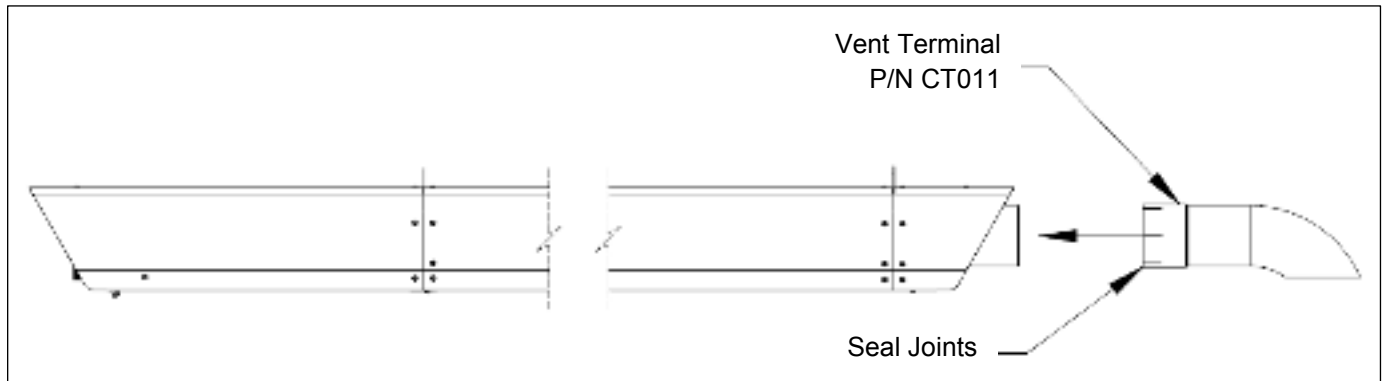

Lighting & Shutdown Instructions

Lighting

1. Open manual gas supply valve (ensure gas supply lines have been purged).
2. Turn the thermostat up. When the thermostat calls for heat, blower motor will energize.
3. The blower motor will energize.
4. When the motor approaches nominal running RPM, the air-proving switch closes and activates the ignition module.
5. The ignition module, after a pre-purge period of approximately 30 seconds, energizes the igniter. Additionally, the gas valve is energized for this ignition trial period of 15 seconds.
6. If a flame is detected, the ignition sensing rod "reads" a rectification signal and the gas valve remains open. The sparking stops when the flame signal is established.
7. If no flame is detected, the gas valve closes and a 30 sec inter-purge period begins. After the inter-purge, the module repeats the trial for ignition period. If flame is still not established, a third and final inter-purge followed by a final ignition trial cycle begins. After three trials, the module will lockout for a period of approximately 1 hour or until reset. (*Reset is accomplished by removing power from the module for at least 5 seconds.*) After this 1-hour period, the module re-attempts the full ignition sequence.

Shut Down

1. Turn off power to electronic control.
2. For longer periods of shut down, also close manual gas supply valve.

Maintenance & Trouble Shooting

Maintenance

For best performance, the certain minimal maintenance procedures should be performed before each heating season:

- Before performing any services or maintenance, shut off gas and electrical supply to heater.
- Check condition of forced air blower scroll and motor. Dirt and dust may be blown or vacuumed from the blower.
- Check condition of burner. Remove any foreign objects or debris from inside the burner box or burner cup.
- Inspect the igniter. Replace igniter if there is excessive wear or erosion, breakage or other defects.
- Be sure the burner observation window is clean and free of cracks or holes. Clean or replace as necessary.
- The reflector sections may be cleaned by wiping with a damp cloth.
- A service agency qualified to adjust and repair infrared heaters should be engaged for service other than routine maintenance.
- Be sure exhaust vent terminal and fresh air inlet grill are free from obstructions. If either is restricted, the safety air switch will not operate properly and the heater could fail to operate.
- Check the inside of the heat exchanger tube visually with a flashlight. If carbon or scale are present, scrape or otherwise remove deposits (a wire brush works well)

Trouble Shooting

Blower Motor Fails to Run

- Is the heater plugged in? Is there 115V at the burner receptacle?
- Check blower for obstructions. Replace blower if necessary.

No Gas Supply

- Check to see if manual supply valve to heater is ON.
- Check to see if gas valve knob on heater gas control is ON.
- Supply gas pressure can be checked at 1/8" NPT pressure tap in gas supply system.
- Is combination gas control opening? No manifold pressure indicates valve is closed. Gas pressure downstream of gas control can be measured by connecting a manometer to pressure tap on control. If the valve is closed, either the gas valve or the ignition module is faulty.

Burner Does Not Light

- Is spark visible through site glass during ignition trial? If no, further electrical checks by a qualified service person are required.
- Check to see if gas lines were properly purged of air.
- Check inlet and outlet gas pressure during ignition period.
- Check for proper orifice and air plate.

Burner Does Not Stay Lit

- Check ground wire continuity.
- Check insulation on the igniter leads.
- Measure flame signal current; it should be between 2 to 6 micro amps dc. Minimum 0.8 micro amps.
- Clean flame rod if necessary.
- Replace module if necessary.

Module Error Codes

POTTED [CHANNEL PRODUCTS]

1. FLASH – Air Flow Fault
2. FLASH – Flame Sensor Issue
3. FLASH – Ignition Lockout After 3 Tries
1. FLASH – Gas Valve Not Connected

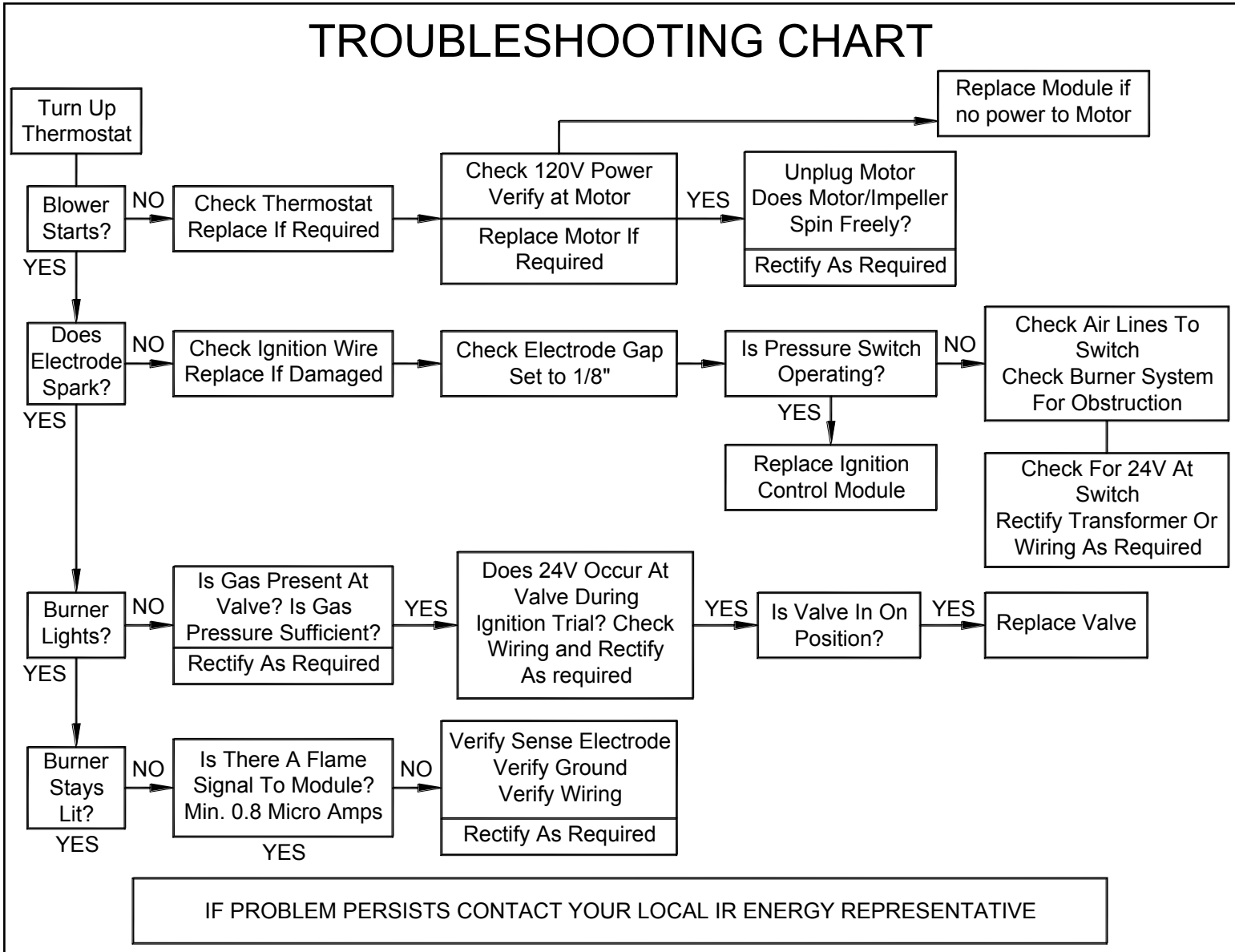

Replacement Parts List

Item	Part No.	Description
1	UG105	Gas Train Assembly for Natural Gas
	UG106	Gas Train Assembly for Propane
2	CE201	Ignition Module
	CE202	Wire Harness w/ 5 pin PLUG to Ignition Module
3	CE382	Blower Motor Assembly w/ 0.20A PSC 2SPD Motor
4	CE058	Transformer, 115V to 24VAC, 40VA
5	CE021	For ETSV 40: Air Switch w/ Bracket, 0.55" w.c.
	CE160	For ETSV 80: Air Switch w/ Bracket, 0.44" w.c.
6	UG001	Burner Cup
	CE002	Electrode for Sparking
	CE003	Electrode for Flame Sense
	CE006	Wire, Ignition
	CE036	Wire, Flame Sense
7	CE057	Operation Light, Amber, 28VAC
8	US225	Grill
9	US215	Service Door
10	US224	Cowling
11	CE173	Blower Motor Relay
-	CE010	Power Cord <i>(Not Shown)</i>

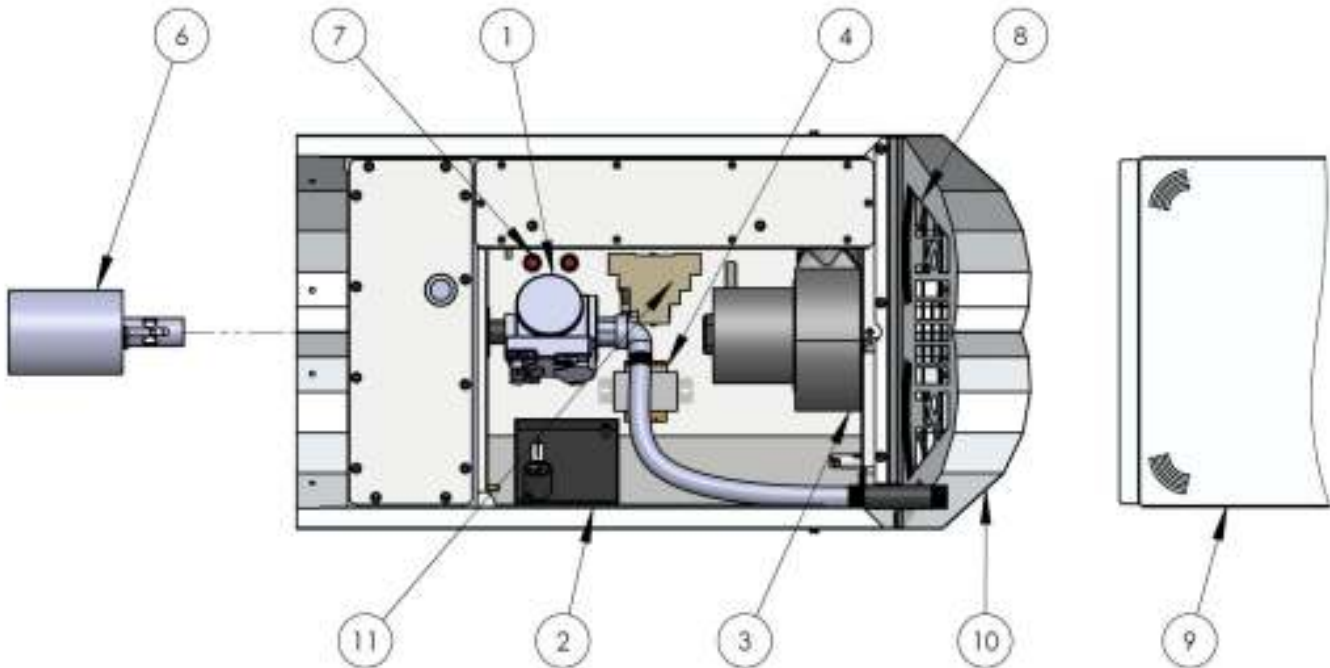



SERIES ETS INFRARED HEATERS WARRANTY

The manufacturer warrants to the original owner that the product will be free of defects in material and workmanship as described below.

Series	Component	Warranty Period			
		3 Years	5 Years	7 Years	10 Years
ETSV	Burner & Controls	*			
	Aluminized Heat Exchanger				*

The Manufacturer's obligation under this warranty is limited to repair or replacement, F.O.B. its facility, of the defective part. In the case of replacement parts, the warranty period shall be the longer of the original warranty or a period of 12 months from the date of purchase. In no event shall the Manufacturer be liable for incidental expense or consequential damages of any kind.

This warranty does not cover any shipping, installation or other costs incurred in the repair or replacement of the product. No materials will be accepted for return without authorization.

This warranty will not apply if in the judgment of the Manufacturer, the equipment has been improperly installed, unreasonably used, damaged or modified.

This warranty will not apply to damage to the product when used in corrosive atmospheres and in particular atmospheres containing halogenated hydrocarbons. No person is authorized to assume for the Manufacturer any other warranty, obligation or liability.

THE REMEDIES PROVIDED FOR IN THE ABOVE EXPRESS WARRANTIES ARE THE SOLE AND EXCLUSIVE REMEDIES. NO OTHER EXPRESS OR IMPLIED WARRANTIES ARE MADE INCLUDING, BUT NOT LIMITED TO, ANY IMPLIED WARRANTY OF MERCHANTABILITY OR FITNESS FOR A PARTICULAR USE OR PURPOSE.