

Intelliluxe Oven

The Intelliluxe oven features the most advanced in-floor heating system ever in a stone hearth oven. With smart technologies in an incredibly durable oven, the Intelliluxe will change the way you cook forever.

Pizza Capacity Per Hour

Size	8"	10"	12"	16"
Pizzas Per Hour	550	410	320	200

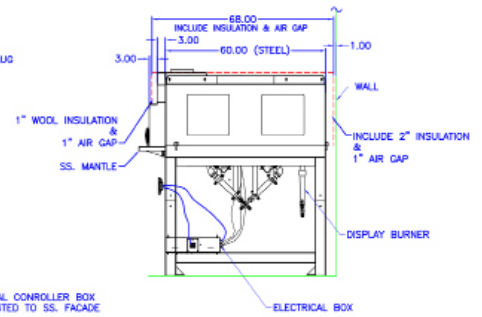
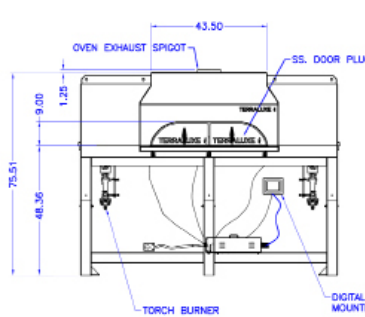
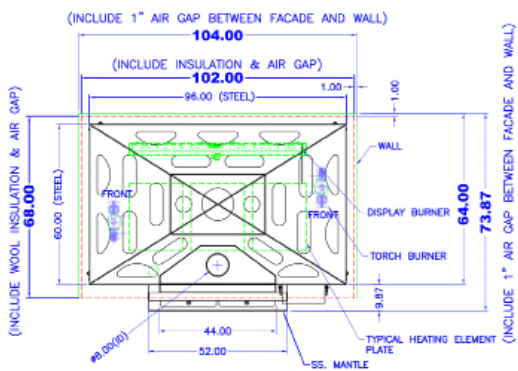

CFM	1400 CFM Minimum	Voltage	240
Gas Burners	up to 3	BTUs	up to 450,000
Cooking Surface	32 sq. ft.	Fuel Options	Gas, Wood, Gas/Wood
Automatic High/Lo Burners	Yes	Gas Type	Propane/Natural
Touchscreen Interface	Yes	Duct Size	10"
In-floor Heating	Yes	Machine Weight	10500 lbs

The Intelliluxe comes in two (2) sections:

1. Oven Body - 7000lbs.
2. Base Section - 3500lbs.

*Removable lower leg section makes for easy installation with standard door access (32").

SERVICES REQUIRED

Full Gas: 450,000 BTU
Gas Back Up: 76,000 BTU.

3/4" Gas connection. NFPA-96 approved flue ducting.