



Smart Fitness Scale

Model: ESF24 Series

User Manual



Questions or Concerns?
support.eu@etekcity.com

Table of Contents

Package Contents	3
Specifications	3
Safety Information	4
Function Diagram	6
Display Diagram	7
Before First Use	8
VeSync App Setup	9
Using the Smart Scale	12
Maintenance	14
Common Display Codes	16
Troubleshooting	17
Terms & Policy	19
Customer Support	19

Specifications

Weight Capacity	180 kg / 28 st / 400 lb
Increments	0.05 kg / 0.2 lb
Weight Units	kg / st / lb
Platform	Tempered Glass
Battery	3 x 1.5V AAA batteries
Auto-Off	30 seconds
Dimensions	30 x 30 x 2.5 cm / 11.8 x 11.8 x 1 in
Operating System	iOS® 9.0+ or Android™ 5.0+

Package Contents

- 1 x Smart Fitness Scale
- 3 x 1.5V AAA Batteries (Pre-Installed)
- 1 x Quick Start Guide



READ AND SAVE THESE INSTRUCTIONS

Safety Information

Please read and follow all instructions and safety guidelines in this manual.

Medical

- This scale should not be used to diagnose or treat any medical condition.
- Scale data should not be used as a substitute for medical advice from a healthcare professional.
- This scale uses a harmless electrical current to measure body fat. Consult a healthcare professional before using the smart scale if you use medical electronic equipment such as a pacemaker.

General Use

- Check the scale before using. **Do not** use the scale if it is damaged in any way.
- **Do not** strike or hit the scale. **Do not** use the scale if the glass is cracked or broken. Due to the nature of tempered glass, the glass will shatter if there is even a slight crack. If you see a crack, contact **Customer Support** immediately (page 19).



- The glass platform is slippery when wet. **Always** make sure the platform and your feet are dry before stepping on for measurement.
- Place the scale on a hard, flat surface to avoid tipping.
- To weigh safely and accurately, stand with your feet shoulder-width apart while on the scale. **Do not** stand on the edge of the scale or jump on the scale.
- Avoid standing on the scale for a long period of time, or when you are not weighing yourself.
- **Do not** overload the scale. Maximum weight capacity is 180 kg / 28 st / 400 lb.
- Keep the scale in a cool area with low humidity. Keep the scale away from heat sources, such as ovens or heaters. Avoid temperature fluctuations. Store the scale in a horizontal position, not vertical.
- Handle with care. Not for commercial use. Household use **only**.

Batteries

- **Do not** mix new and old batteries.
- If the scale is not in use for a long period of time, remove the batteries to extend the lifetime of the scale.



Function Diagram

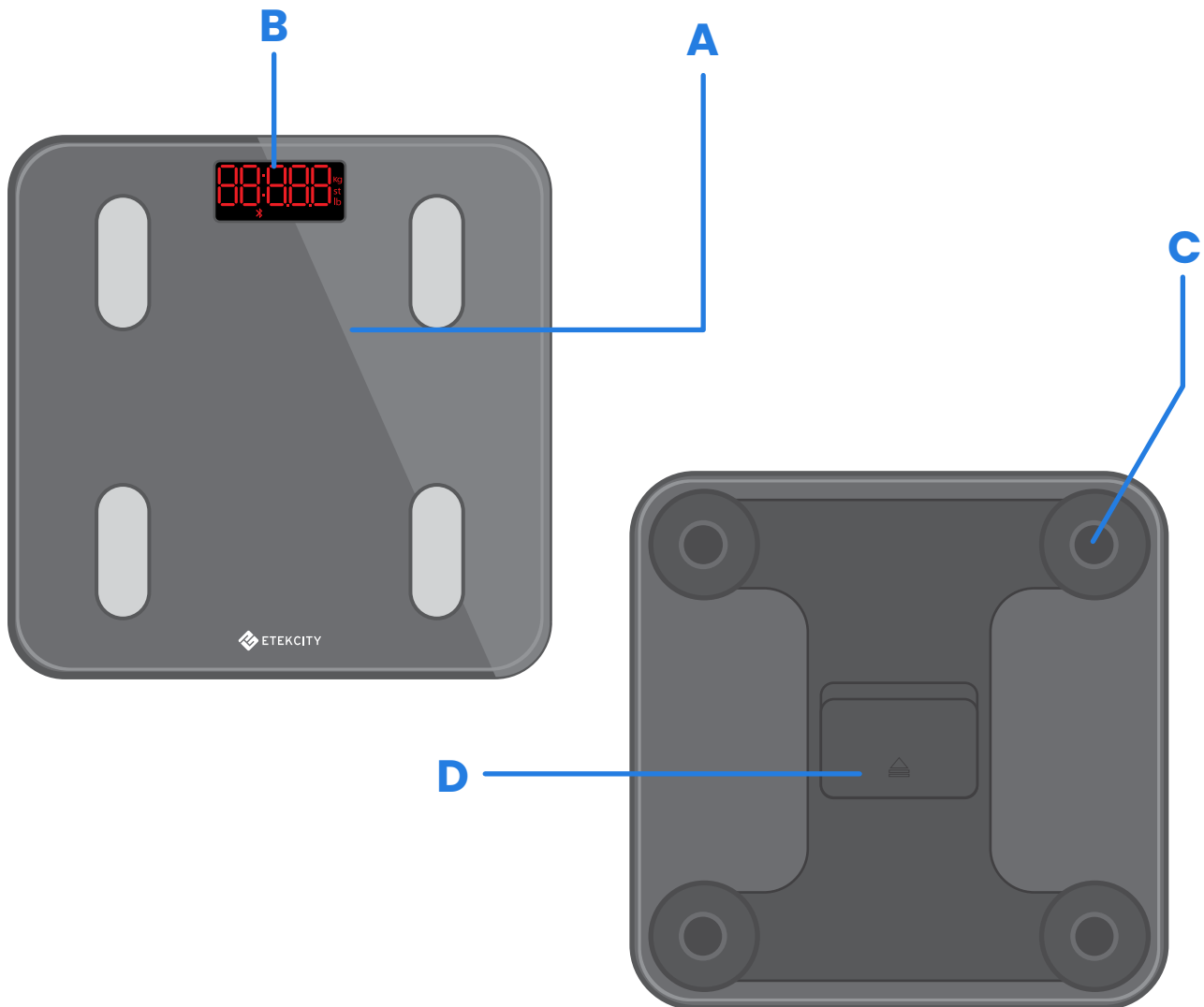

- A.** Weighing Platform
- B.** Display
- C.** Anti-Skid Padding
- D.** Battery Compartment



Display Diagram

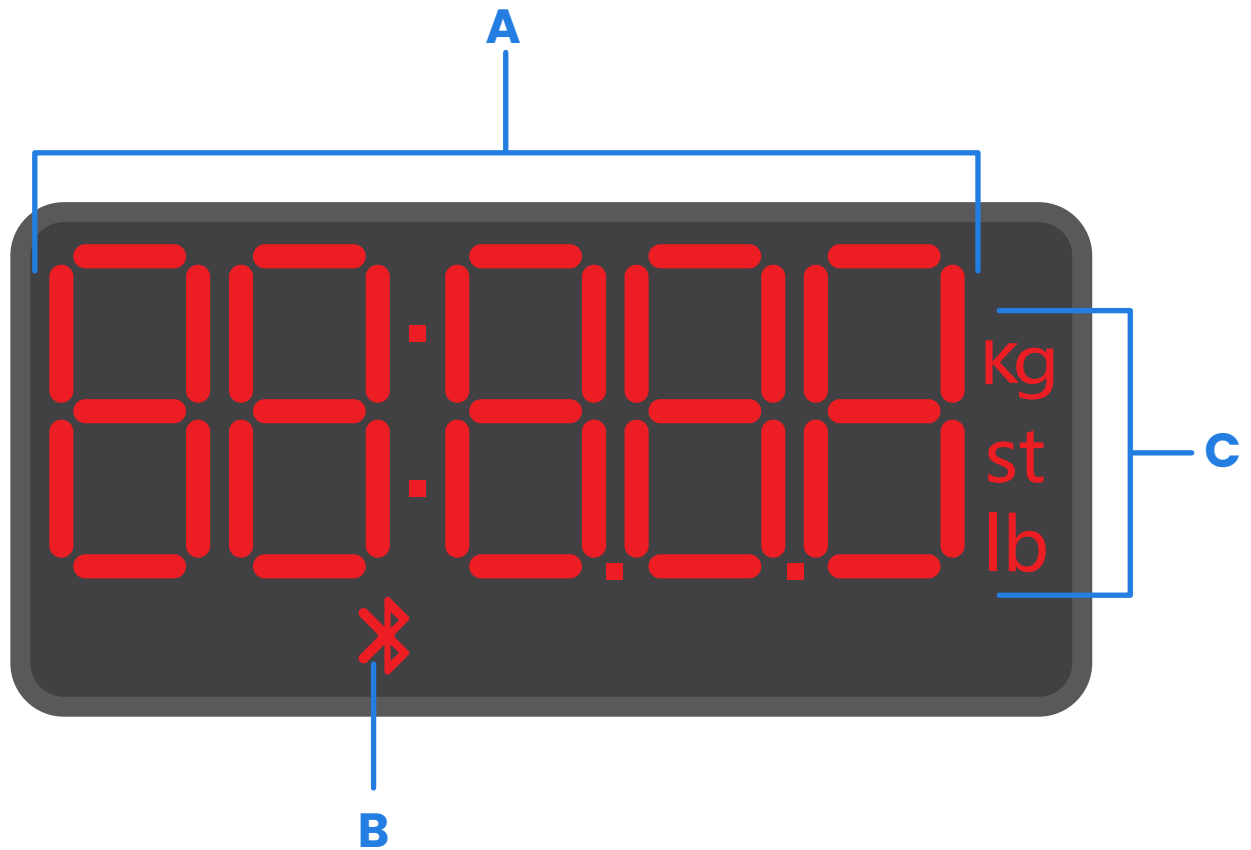

- A.** Weight Measurement
- B.** Bluetooth[®] Icon
- C.** Weight Units



Before First Use

1. Open the battery compartment on the underside of the scale. Remove the included AAA batteries.
2. Remove the plastic insulator strip from the battery compartment.
3. Replace the batteries. Follow the guidelines in the battery compartment to match the **+** and **-** terminals.

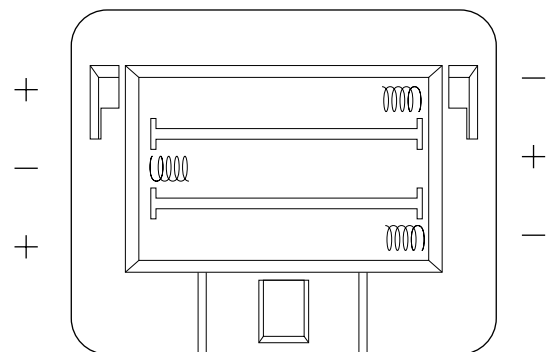
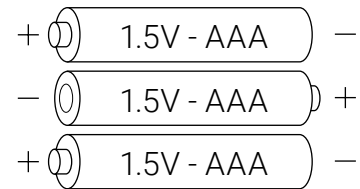
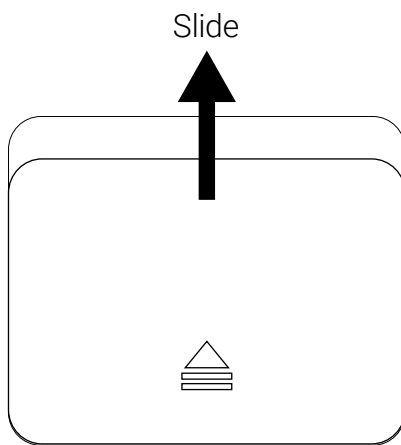

VeSync App Setup

Note: Due to app updates and improvements, the VeSync app may be slightly different than shown in the manual. In case of any differences, follow the in-app instructions.

1. To download the VeSync app, scan the QR code or search “VeSync” in the Apple App Store® or Google Play Store.

Note:

- This scale uses the VeSync app, not the VeSyncFit app.
- For Android users, you may need to select “Allow” to use VeSync.



2. Open the VeSync app. If you already have an account, tap **Log In**. To create a new account, tap **Sign Up**.

Note: You must create your own VeSync account to use third-party services and products. These will not work with a guest account. With a VeSync account, you can also allow your family and friends to use your smart fitness scale.

3. Make sure the scale is fully charged.
4. Make sure your phone has Bluetooth® turned on.
5. Tap **+** in the VeSync app and select your smart fitness scale.
6. Follow the in-app instructions to connect to your smart fitness scale.

Note: You can change the name and icon at any time in the smart fitness scale settings.



Creating a User

If you are a new user, you will need to enter physical information before weighing yourself for the first time so the scale can calculate your body metrics. Follow the in-app instructions to create a user.

Note:

- *Entering inaccurate information will make the scale's measurements less accurate.*
- *If you don't identify with the available gender options, or are unsure, pick the option that you think best physically matches you. This choice is used for physical measurements, such as body fat percentages.*



Using the Smart Scale

Note:

- To switch between pounds (lb), stone (st), and kilograms (kg), open the VeSync app and select the weight unit in the Device Settings menu.
- To see measurements besides weight, you must connect the scale to the VeSync app (see page 9).
- If you are pregnant, scale measurements will not be accurate.

1. Place the scale on a hard, flat surface (not a carpet or mat). **[Figure 1.1]**

Note: Placing on carpet may cause inaccurate measurements or tipping.

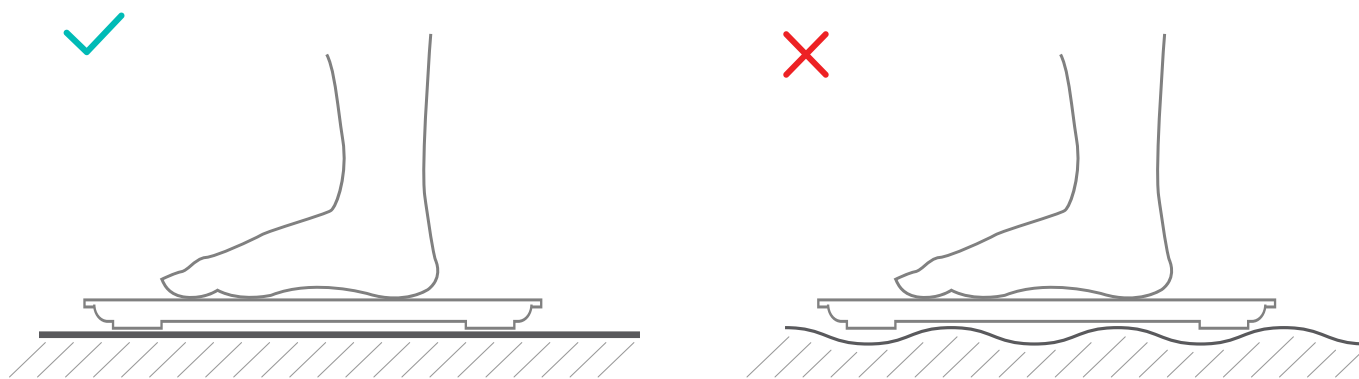

[Figure 1.1]



2. Make sure your feet are dry. Place bare feet on the scale's conductive areas. Step onto the scale. The scale will automatically turn on and start measuring your weight.
3. Continue standing on the scale until the digits on the display flash 2 times, showing your final measurement.
[Figure 1.2] If your smart scale is connected to the VeSync app, additional results (such as BMI, body fat, etc) will show in the app.

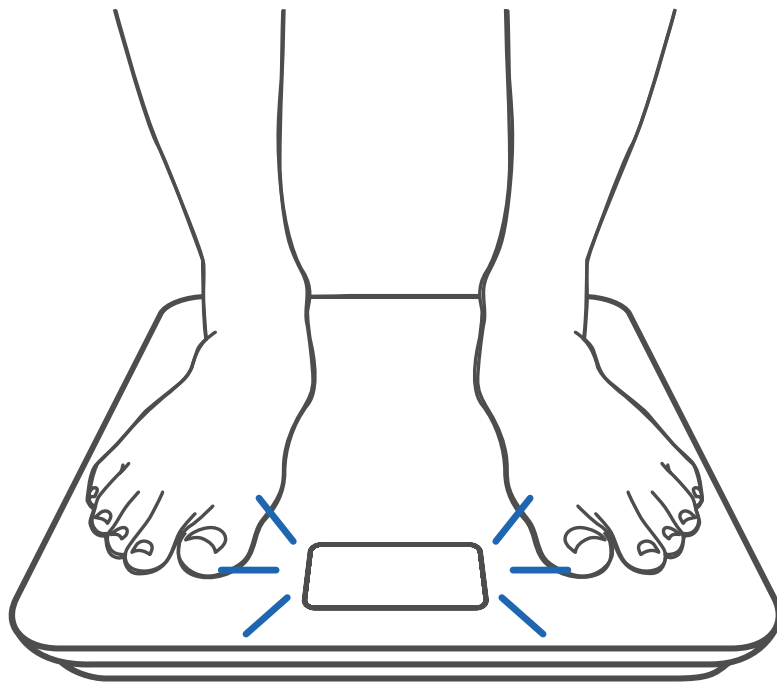

[Figure 1.2]



Maintenance

Calibrating the Smart Scale

If the scale has been moved or flipped upside down, it must be calibrated to ensure accurate results.

1. Place the scale on a hard, flat surface.
2. Step on the scale with 1 foot until digits appear on the display, then step off. [\[Figure 2.1\]](#)
3. The scale will show “CAL” while calibrating, then “000” when calibration is complete. [\[Figure 2.2\]](#)

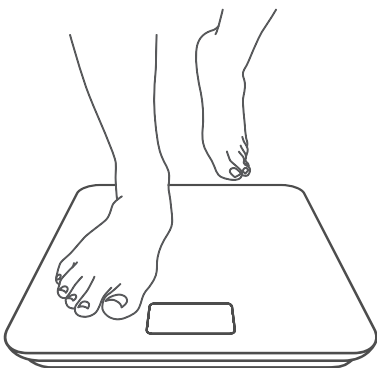

[\[Figure 2.1\]](#)

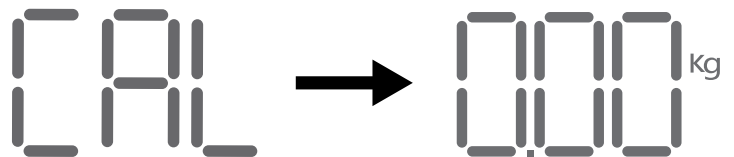

[\[Figure 2.2\]](#)



Cleaning the Smart Scale

- Use a slightly damp cloth to clean the surface of the scale, followed by a soft, dry cloth to wipe away any remaining moisture.
- **Do not** use chemical or abrasive cleaning agents to clean the scale.

Replacing the Batteries

The display will show “” when the batteries need to be replaced.

1. Open the battery compartment on the underside of the scale.
2. Remove the old batteries and dispose of them properly.
3. Install 3 new 1.5V AAA batteries, making sure they are placed under the correct polarity.
4. Replace the battery compartment cover.

Note: *The scale may need to be calibrated after replacing the batteries.*



Common Display Codes



Wireless Connection



No Wireless Connection



Calibrating



Overload



Change Battery



Troubleshooting

The scale doesn't turn on.

- Check if the batteries are properly installed. If using the scale for the first time, remove the plastic insulator strip from the battery compartment.

Information flashes on the display and then disappears.

- The batteries are low and may need to be replaced.

The smart scale doesn't connect with the VeSync app.

- Make sure your phone's operating system is running on iOS 9.0+ or Android 5.0+.
- Close and relaunch the VeSync app. Make sure you're using the latest version.
- Make sure your phone has Bluetooth turned on. For Android users, make sure your Location is turned on as well.
- Make sure your scale and phone are within 10 m / 30 ft of each other.
- Make sure the scale is not currently connected to any other phone or app.
- Try turning off any VPN apps.



My scale will only measure my weight, not my body fat or other metrics.

- Set up your smart scale in the VeSync app. Your weight will show on the scale display, and more results will show on the app.
- If you're wearing shoes or socks, the scale cannot measure health metrics such as body fat. Step on the scale with bare feet. [\[Figure 3.1\]](#)
- Make sure to place your feet on the scale's conductive areas. [\[Figure 3.2\]](#)

Note: If the scale has errors on the display, will not turn off automatically, or has a problem not listed here, try removing the batteries for 3 seconds, then replacing them.

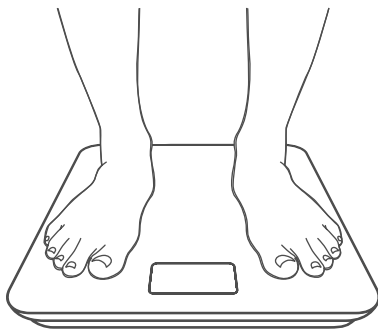

[\[Figure 3.1\]](#)

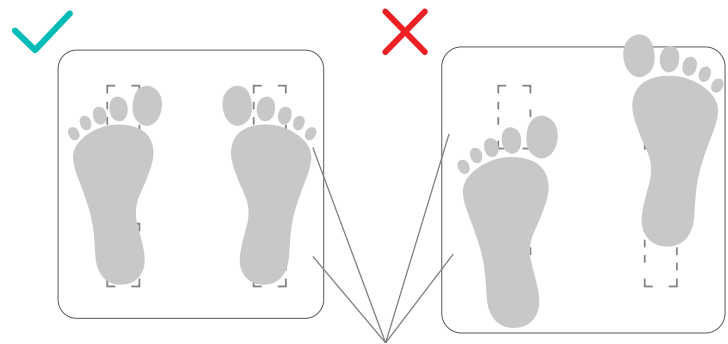

Conductive Areas

[\[Figure 3.2\]](#)

If you still need help, please contact [Customer Support](#) (page 19).



Attributions

iOS is a registered trademark of Cisco Systems, Inc. and/or its affiliates in the United States and certain other countries.

Apple App Store is a trademark of Apple Inc.

Android and Google Play are trademarks of Google LLC.

The Bluetooth® word mark and logos are registered trademarks owned by Bluetooth SIG, Inc. and any use of such marks by Etekcitey Corporation is under license.

Terms & Policy

Etekcitey Corporation warrants all products to be of the highest quality in material, craftsmanship, and service for 2 years, effective from the date of purchase to the end of the warranty period. Warranty lengths may vary between product categories.

If you have any questions or concerns about your new product, please contact our helpful Customer Support Team.

Customer Support

Etekcitey Corporation

1202 N. Miller St., Suite A
Anaheim, CA 92806
USA

Email: support.eu@etekcity.com

**Please have your order invoice and order ID ready before contacting Customer Support.*



Connect with us @EtekcitcityUK

