



EARTHLIGHT
EXTERMINATOR
LED HIGH BAY UFO SERIES



CE RoHS 

GENERAL SPECIFICATIONS

Models	ETG-EXTHB-100 / 150 / 200 / 240
Input Voltage	90-305 VAC 50/60Hz
Lm/W	150lm/W
Lumen Range	15,000 ~ 36,000
IP Rating	IP65
Light Source	Phillips
Material	ALU alloy +PC Cover
Beam Angle	60° / 90° / 120°
CRI	>80
LED Driver	Meanwell ELG
Mounting	Eye bolt Hook / Tilttable Bracket / Pole mount
Life span	>50,000
Warranty	5 Years

FEATURES

- » Ultra modern design with high heat dissipation
- » High Intensity light output
- » Low power consumption
- » Long life endurance
- » CE, RoHS, SAA

APPLICATIONS

- Office
- Warehouse
- Gas station
- Supermarket
- Train station
- Workshop
- Factory
- Airport
- Sports Arena
- Store room
- Service Centre
- Building exterior

SPECIFICATION

MODEL	ETG-EXTHB-100	ETG-EXTHB-150	ETG-EXTHB-200	ETG-EXTHB-240
Power(W)	100W	150W	200W	240W
Light Source	Phillips			
Driver	Meanwell ELG			
CCT(K)	2200K / 6500K			
IP Rating	IP65			
AC Input	90-305 VAC 50/60Hz			
Inrush Current	6.6A			
Operating Temperature	-30 ~ +45°C			
Lm/W	150 lm/W			
Lumen (lm)	15,000lm	22,500lm	30,000lm	36,000lm
Power Factor	>97%			
THD	<15%			
CRI	>80			
Life span	>50,000 Hrs			
Warranty	5 Years			

ACCESSORIES

HIGH POLE MOUNT



EYE BOLT HOOK



BRACKET MOUNT



PRISMATIC REFLECTOR



WHITE BODY



PHOTOMETRIC DIAGRAM

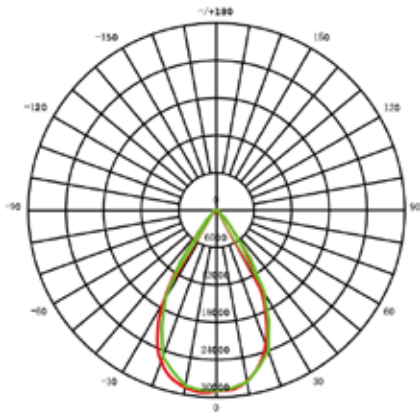

60°

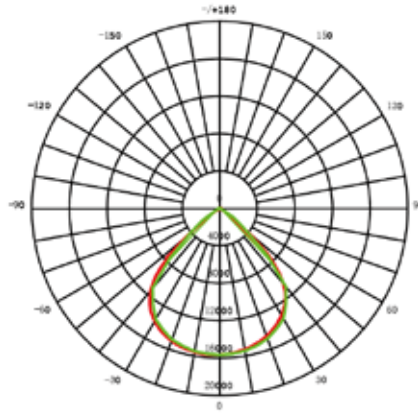

90°

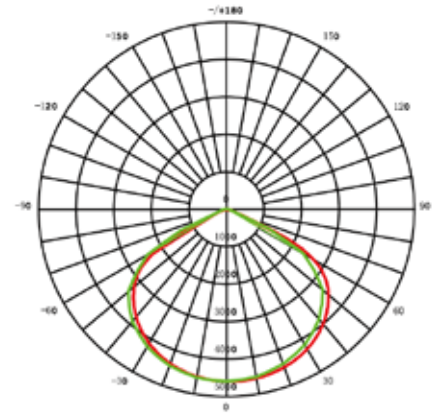

120°

DIMENSION

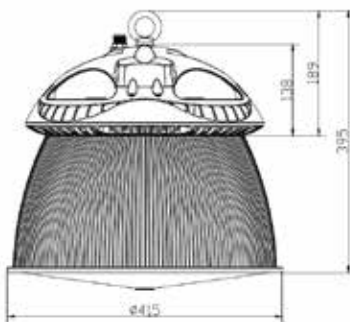
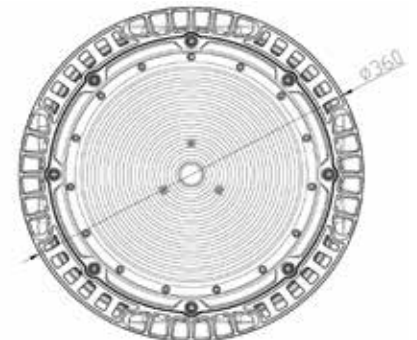
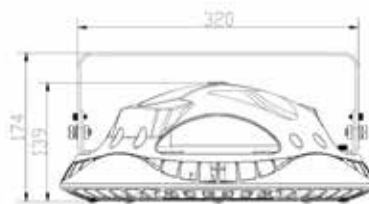
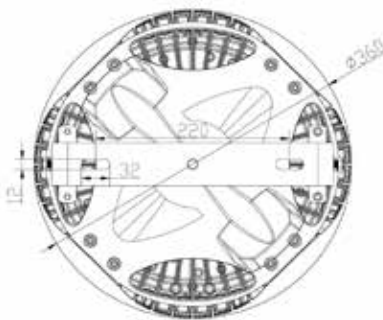

DISCLAIMER

Important Statement of warranty.

Earthtrack reserves the right to change or discontinue a product and / or specification without notice. All warranty periods only cover faulty workmanship and / or material components. Any claims on misused or disassembled products will not be recognized by Earthtrack. All information enclosed in this catalogue, to our knowledge, was correct at time of print.